

I/32096/2022



भारत सरकार – रेल मंत्रालय
अनुसंधान अभिकल्प और मानक
संगठन लखनऊ- 226011
Tele : (0522) -2465165
Fax : (0522) -2452494

Government of India - Ministry of Railways
Research Designs & Standards
Organisation Lucknow – 226011
DID (0522) 2450115
DID (0522) 2465310



MW/APB/BMB/Escorts

Date: 29.08.2022

The PCMEs

All Zonal Railways

Sub:- Bell crank lever failures / brake cylinder hanging cases in BMBS of M/s Escorts make design

Zonal Railways have reported bell crank lever failure /Brake cylinder hanging cases in M/s Escorts make BMBS. The matter was referred to OEM and the same has been informed by them that the predominant reason for such failures is use of bell crank lever with oblong hole, use of non-standard bell crank lever pins, improper locking of bell crank lever pin instead with standard spring dowel sleeve with bush arrangement/split pin as applicable, U clamp safety brackets being not properly welded etc. (Pictures attached)



Fig (i)- Improper welding of U- clamp safety bracket for brake cylinder hanging



Fig (ii) - Bell crank lever with oblong hole

I/32096/2022



Fig (iii) - Improper locking of bell crank lever pin instead with standard spring dowel sleeve with bush arrangement



Fig (iv) - Use of non-standard bell crank lever pins

In order to avoid recurrence of such incidences, following instructions are issued: -

- 1- Standard pins of bell crank lever (as mentioned in para 1.5 of Escorts operation & Maintenance manual of BMBS) to be used.
- 2- Proper welding of U-bracket (welded to under frame for the purpose of securing the brake cylinder through safety chain) is to be ensured.
- 3- Proper locking of bell crank lever pins (as mentioned in para 1.5 of Escorts operation & maintenance manual of BMBS) is to be ensured.
- 4- Proper checking of bell crank lever as per para 3.7.2 of Operation & maintenance manual of BMBS of the firm.
- 5- Other maintenance instructions as advised by the OEM through their maintenance manual. Copy of the maintenance manual is also enclosed herewith.

Digitally Signed by

Shailendra Kumar Sharma

Date: 29-08-2022 10:36:34

Reason: Approved

(शैलेंद्र कुमार शर्मा)

निदेशक/वैगन

कृते कार्यकारी निदेशक/वैगन

I/32096/2022

All PCME's

- (i) Central Railway, CST, Mumbai-400001
- (ii) Eastern Railway, Fairlie Place, Kolkata-700001
- (iii) East Central Railway, Hajipur- 844 101
- (iv) East Coast Railway, Railway Complex, Bhubaneswar-751023
- (v) Northern Railway, Baroda House, New Delhi-110001
- (vi) North Central Railway, Allahabad.-211001
- (vii) North Western Railway, Jaipur-302006
- (viii) North Eastern Railway, Gorakhpur-273001
- (ix) Southern Railway, Park Town, Chennai-600003
- (x) South Central Railway, Secunderabad-500071
- (xi) South Eastern Railway, Garden Reach, Kolkata-700043
- (xii) South East Central Railway, R.E. Complex, Bilaspur - 495004
- (xiii) South Western Railway, Hubli - 580023
- (xiv) Northeast Frontier Railway, Maligaon, Guwahati-781011
- (xv) Western Railway, Churchgate, Mumbai-400020
- (xvi) West Central Railway, Jabalpur-482001

Copy to- EDME/Freight/RB- for kind information.

I/32096/2022

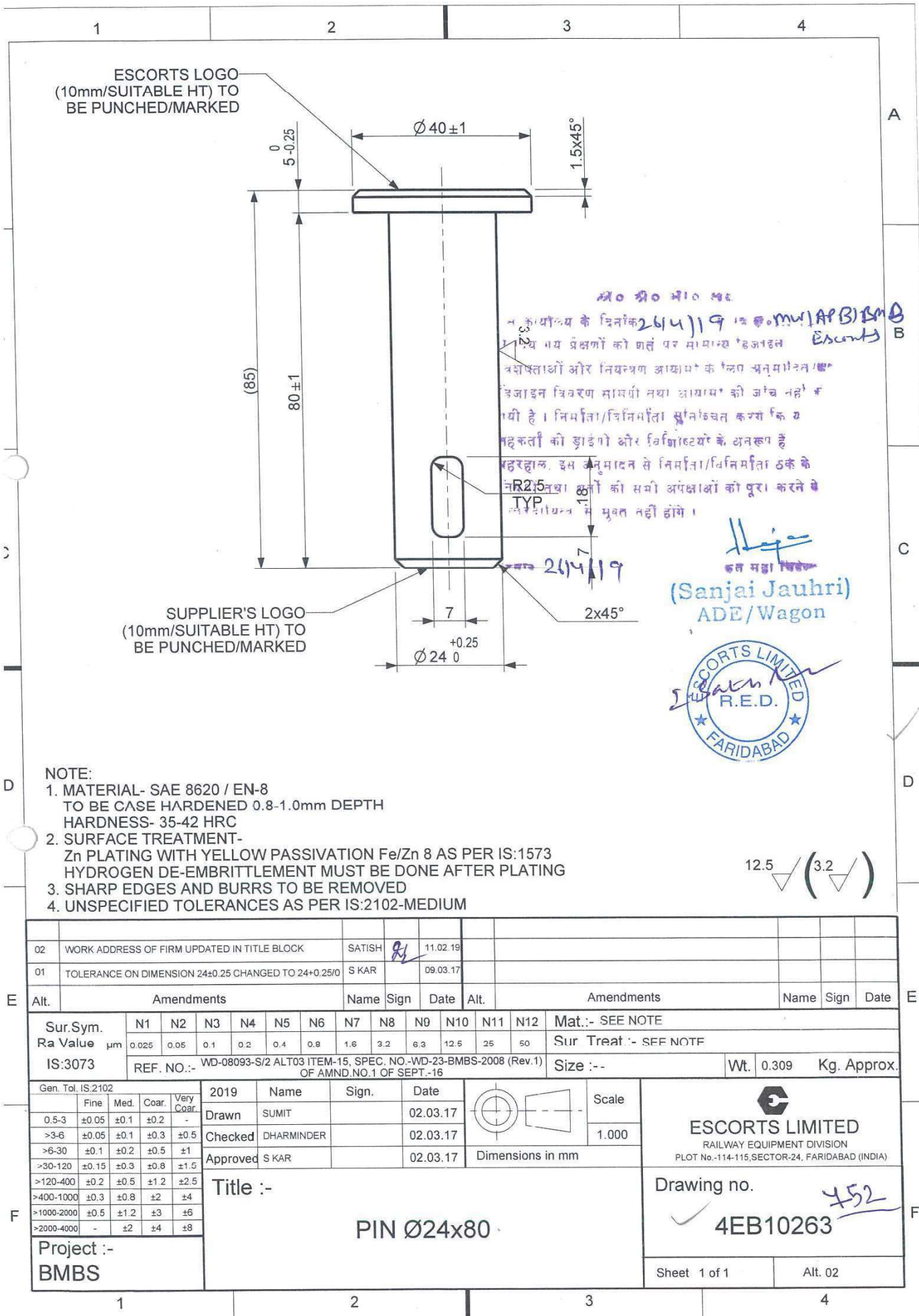

02	WORK ADDRESS OF FIRM UPDATED IN TITLE BLOCK	SATISH	11.02.19
01	TOLERANCE ON DIMENSION 24±0.25 CHANGED TO 24+0.25/0	S KAR	09.03.17

Alt.	Amendments	Name	Sign	Date	Alt.	Amendments	Name	Sign	Date
	Sur.Sym. N1 N2 N3 N4 N5 N6 N7 N8 N9 N10 N11 N12	Mat.:- SEE NOTE							
	Ra Value µm 0.025 0.05 0.1 0.2 0.4 0.8 1.6 3.2 6.3 12.5 25 50	Sur Treat :- SEE NOTE							
	IS:3073	REF. NO.:- WD-08093-S/2 ALT03 ITEM-15, SPEC. NO.-WD-23-BMBS-2008 (Rev.1) OF AMND.NO.1 OF SEPT.-16				Size :-	Wt. 0.309	Kg. Approx.	

Gen. Tol. IS:2102	2019	Name	Sign.	Date	Scale	ESCORTS LIMITED RAILWAY EQUIPMENT DIVISION PLOT No.-114-115,SECTOR-24, FARIDABAD (INDIA)
Fine	Drawn	SUMIT		02.03.17	1.000	
Med.	Checked	DHARMINDER		02.03.17		
Coar.	Approved	S KAR		02.03.17		
Very Coar.	Title :-				Dimensions in mm	Drawing no.
0.5-3	PIN Ø24x80					4EB10263
0.5-3						452
>3-6						Sheet 1 of 1
>6-30						Alt. 02
>30-120						
>120-400						
>400-1000						
>1000-2000						
>2000-4000						

Project :-
BMBS

∅6.4-∅6.7

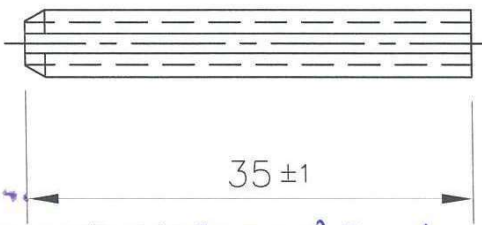
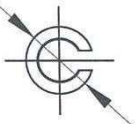

अज्ञेय के दिनांक 26/4/19 को म.म. (APB) (BMBS) Escorts
 के यंत्रणों को जत पर मान्य विवरण
 विशेषताओं और नियंत्रण आकार के लिए अनुमति/अनु
 विवरण प्रदान किया गया है। जांच नहीं की
 जायेगी। निर्माण/निर्माता सुनिश्चित करें कि ये
 प्रदान की गई विशेषताओं के अनुरूप हैं।
 बहुरहस्य।
 नियमों तथा शर्तों का पालन करके प्रदान की
 वस्तुदायित्व से मुक्त नहीं है।



दिनांक 26/4/19

(Sanjay Jadhri)
 ADE/Wagon

NOTE:-

FOR OTHER DETAILS, REFER IS: 5988/ISO: 8752/EQUIVALENT

1 WORK ADDRESS OF FIRM UPDATED IN TITLE BLOCK													SATISH		11.02.19																						
Alt.			Amendments						Name		Sign		Date		Alt.			Amendments						Name		Sign		Date									
Sur.Sym.		N1		N2		N3		N4		N5		N6		N7		N8		N9		N10		N11		N12		Matl.-SEE NOTE											
Ra Value μm		±0.05		±0.1		±0.2		±0.3		±0.5		±1		±2		±3		±4		±5		±6		±7		±8		±9		±10		Sur. Treat.-NIL					
IS: 3073		REF. NO.: - WD-08093-S/2 ALT03 ITEM-21 & SPEC. NO.-WD-23-BMBS-2008 (Rev.1)																								Size -NIL		Wt. 0.003kg APPROX									
Gen. Tol. IS: 2102			2019		Name		Sign.		Date		Scale		Scale 2:1 Dimensions in mm						ESCORTS LIMITED RAILWAY EQUIPMENT DIVISION PLOT No.-114-115, SECTOR-24, FARIDABAD (INDIA)																		
Fine		Med.		Coar.		Very Coar.		Drn.		Sumit		15.03.17																									
0.5-3		±0.05		±0.1		±0.2		Chkd.		Dharminder		15.03.17																									
>3-6		±0.05		±0.1		±0.3		Appd.		S Kar		15.03.17																									
>6-30		±0.1		±0.2		±0.5		Title :-		SPRING DOWEL SLEEVE		Drawing no.													4EB10260												
>30-120		±0.15		±0.3		±0.8		±1.5		Project :-		BMBS		Sheet 1 of 1		Alt. 01																					
>120-400		±0.2		±0.5		±1.2		±2.5		∅6x35																											
>400-1000		±0.3		±0.8		±2		±4																													
>1000-2000		±0.5		±1.2		±3		±6																													
>2000-4000		-		±2		±4		±8																													

753

I/32096/2022

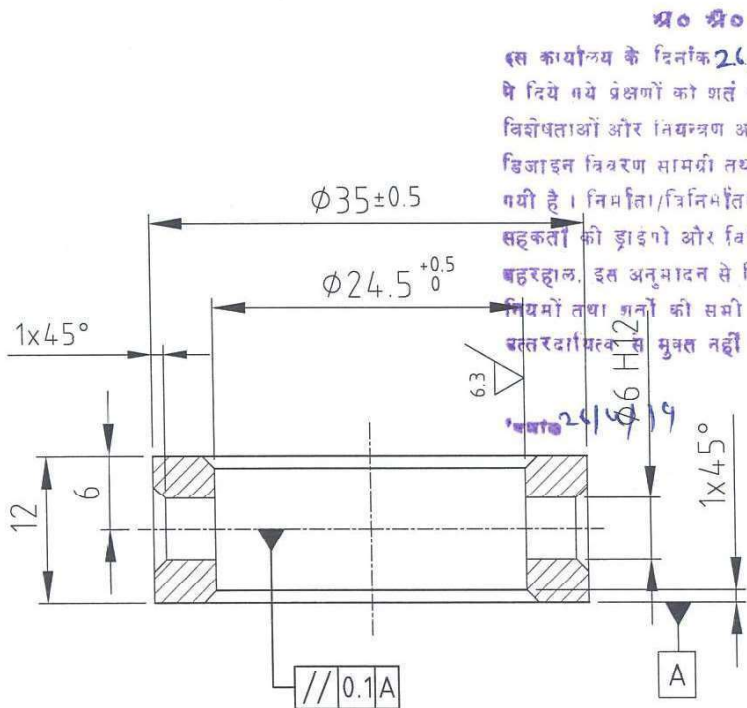

श्री श्री श्री संतो
 इस कार्यालय के दिनांक 26/11/19 के मंत्रालय में प्रेषित प्रेषणों को शर्त पर सामान्य इंजीनियरिंग विभागों और नियंत्रण आकाश के लिए अनुमति/डिजाइन विवरण सामग्री तथा आयामों की जांच नहीं की गयी है। निर्माता/वितरिता सुनिश्चित करें कि यह सहकर्मियों की जांचों और विनिर्देशों के अनुरूप है बहरहाल, इस अनुमति से निर्माता/वितरिता के नियमों तथा शर्तों की सभी अपेक्षाओं को पूरा करने के उत्तरदायित्व से मुक्त नहीं होंगे।

(Sanjai Jauhari)
 ADE/Wagon



NOTE:

- 1) Sur. Treat.-Fe/Zn 8-15 PLATING WITH YELLOW PASSIVATION
- 2) BREAK ALL SHARP EDGES & CORNERS
- 3) UNSPECIFIED TOLERANCES ON DIMENSIONS ARE AS PER IS:2102-MEDIUM.

12.5 / (6.3)

01		WORK ADDRESS OF FIRM UPDATED IN TITLE BLOCK		SATISH	11.02.19													
Alt.		Amendments		Name	Sign	Date	Alt.		Amendments		Name	Sign	Date					
Sur.Sym.		Ra Value μ m		N1	N2	N3	N4	N5	N6	N7	N8	N9	N10	N11	N12	Mat.-E250A TO IS:2062		
IS:3073		REF. NO.:-		0.025	0.05	0.1	0.2	0.4	0.8	1.6	3.2	6.3	12.5	25	50	Sur. Treat.- SEE ABOVE		
		WD-08093-S/2 ALT03 ITEM-20 & SPEC. NO.-WD-23-BMBS-2008 (Rev.1) OF AMND.NO.1 OF SEPT.-16		Size -			Wt.			0.4kg APPROX								
Gen. Tol. IS:2102		2019		Name		Sign.		Date		Scale		ESCORTS LIMITED RAILWAY EQUIPMENT DIVISION PLOT No.-114-115,SECTOR-24, FARIDABAD (INDIA)						
Fine		Med.		Coar.		Very Coar.				1:1								
05-3		±0.05		±0.1		±0.2		-										
3-6		±0.05		±0.1		±0.3		±0.5										
6-30		±0.1		±0.2		±0.5		±1										
30-120		±0.15		±0.3		±0.8		±1.5										
120-400		±0.2		±0.5		±1.2		±2.5										
400-1000		±0.3		±0.8		±2		±4										
1000-2000		±0.5		±1.2		±3		±6										
2000-4000		-		±2		±4		±8										
Project :-		BMBS		Title :-		BUSH		Drawing no.		4EB10261		Sheet 1 of 1		Alt. 01				

754

I/32096/2022

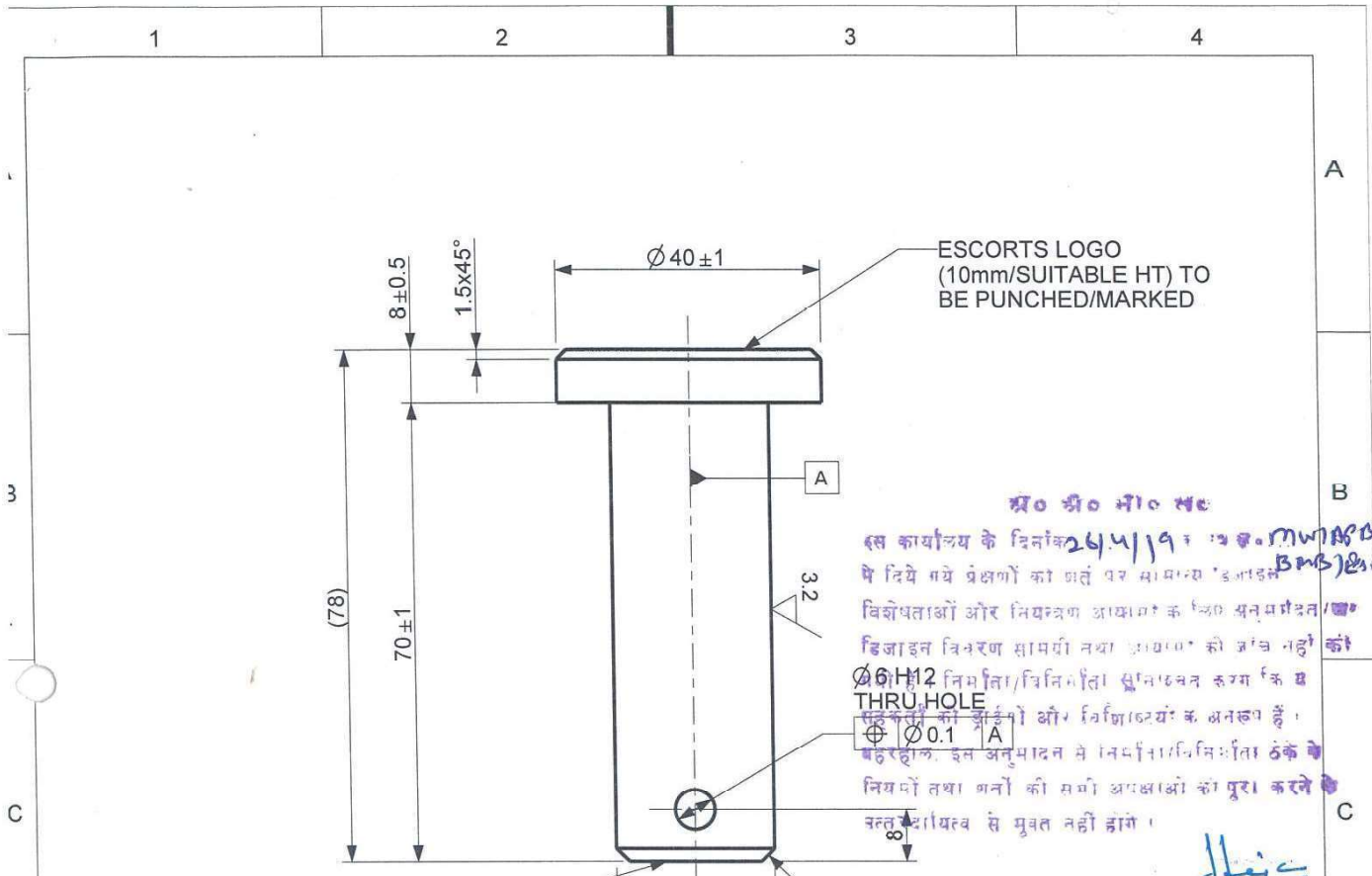

ESCORTS LOGO (10mm/SUITABLE HT) TO BE PUNCHED/MARKED

SUPPLIER'S LOGO (10mm/SUITABLE HT) TO BE PUNCHED/MARKED

श्री 0 श्री 0 श्री 0 से
 इस कार्यालय के दिनांक 24/4/19 को श्री 0 MWA/ABD
 से दिये गये प्रश्नों को ज्ञात पर सामान्य इंजीनियरिंग
 विशेषताओं और नियंत्रण आकाश के लिए अनुमति/का
 डिजाइन विवरण सामग्री तथा उपयोग की जांच नहीं की
 Ø40H12 निर्माता/विनिर्माता सुनिश्चित करे कि यह
 THRU HOLE
 Ø0.1 A और विनिर्माताओं के अनुरूप हैं।
 बंद होना। इस अनुमति से निर्माता/विनिर्माता ठेके के
 नियमों तथा शर्तों की सभी अपेक्षाओं को पूरा करने के
 लक्ष्य से मुक्त नहीं होंगे।

Sanjai Jauhari
 ADE/Wagon
 ESCORTS LIMITED
 R.E.D.
 FARIDABAD

- NOTE:
 1. MATERIAL- SAE 8620 / EN-8
 TO BE CASE HARDENED 0.8-1.0mm DEPTH
 HARDNESS- 35-42 HRC
 2. SURFACE TREATMENT-
 Zn PLATING WITH YELLOW PASSIVATION Fe/Zn 8 AS PER IS:1573
 HYDROGEN DE-EMBRITTLMENT MUST BE DONE AFTER PLATING
 3. SHARP EDGES AND BURRS TO BE REMOVED
 4. UNSPECIFIED TOLERANCES AS PER IS:2102-MEDIUM

12.5 (3.2)

02	WORK ADDRESS OF FIRM UPDATED IN TITLE BLOCK	SATISH	9/	11.02.19											
01	TOLERANCE ON DIMENSION 24±0.25 CHANGED TO 24+0.25/0	S KAR		09.03.17											
Alt.	Amendments	Name	Sign	Date	Alt.	Amendments	Name	Sign	Date						
Sur.Sym.	N1 N2 N3 N4 N5 N6 N7 N8 N9 N10 N11 N12	Mat.:- SEE NOTE													
Ra Value μm	0.025 0.05 0.1 0.2 0.4 0.8 1.0 0.2 0.3 12.5 25 50	Sur. Treat.:- SEE NOTE													
IS:3073	REF. NO.:- WD-08093-S/2 ALT03 ITEM-16, SPEC. NO.-WD-23-2008 (REV.1) OF AMND.NO.1 OF SEPT.-16										Size :-		Wt. 0.320	Kg. Approx.	
Gen. Tol. IS:2102		2019	Name	Sign.	Date	Scale		<p>ESCORTS LIMITED RAILWAY EQUIPMENT DIVISION PLOT No.-114-115,SECTOR-24, FARIDABAD (INDIA)</p>							
0.5-3	±0.05 ±0.1 ±0.2	Drawn	SUMIT		02.03.17	1,000									
>3-6	±0.05 ±0.1 ±0.3 ±0.5	Checked	DHARMINDER		02.03.17										
>6-30	±0.1 ±0.2 ±0.5 ±1	Approved	S KAR		02.03.17	Dimensions in mm									
		Title :-						Drawing no.							
		PIN Ø24x70						4EB10262							
Project :- BMBS						Sheet 1 of 1		Alt. 02							

455