

**COOLING WATER
SYSTEM
OF
ALCO LOCOMOTIVES**

OBJECTIVES

- Introduction.
- Necessity of cooling.
- Types of cooling system.
- Schematic diagram of cooling water system.
- Cooling water and its treatment.
- Modifications in cooling water system.
- Trouble shooting of cooling water system.

INTRODUCTION

- Chemical energy of fuel is converted to mechanical energy.
 - To push the pistons,
 - Rotate the crankshaft
 - Rotate the armature of TG/TA.
- Approximately two-thirds of the heat produced
 - Either goes out through the Exhaust manifold or
 - Soaked up by the engine itself.

Absorbed by Cooling
system

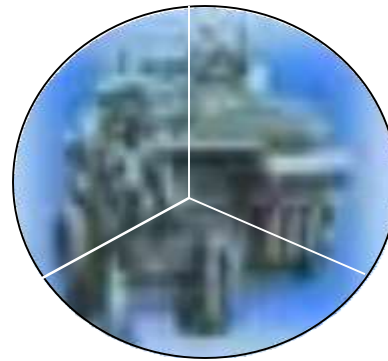

Exhaust

Useful work

NECESSITY OF COOLING THE ENGINE

- The strength of the materials
 - Usually decreases with an increase in temperature,
- High temperature may result in excessive thermal stresses
 - Due to uneven expansion of various engine parts
 - May result in cracking / damages.
- Lubricating oil
 - Deteriorates very rapidly with temperature increase losing all its inherent properties.
 - Might even evaporate and burn ,damaging piston and cylinder head surface.

AIR COOLING SYSTEM

- Natural air either under pressure or without pressure is used.
 - Compressor liners of Alco locos,
 - Charge air in WDS6/ YDM4 locos,
 - Traction machines etc.
- Main limitation
 - Less efficiency and
 - Non-uniform cooling
 - Object which is more exposed gets better cooling as compared to less exposed object.

WATER COOLING SYSTEM

- Water is used as cooling medium.
- Circulated around the object to be cooled.
- The heat of the object to be cooled
 - Absorbed by water thereby cooling the object
 - Water temperature gets elevated
 - Kept under control by separate cooling mechanism.
- Advantage
 - Maintains a uniform level of temperature throughout the engine
 - By controlling the water temperature, the engine temperature can be controlled effectively.

COOLING WATER SYTEM OF ALCO LOCOMOTIVE

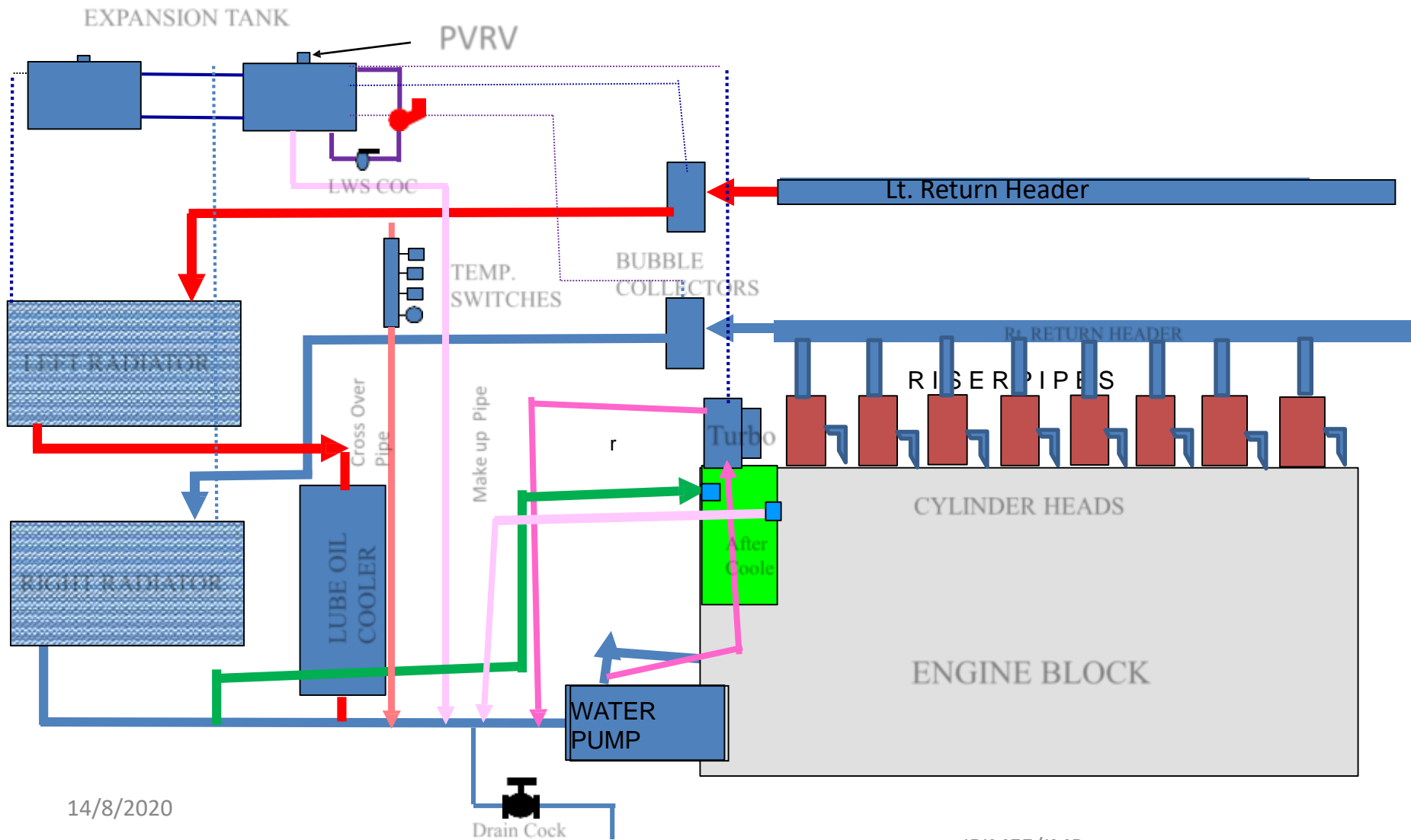

14/8/2020

IRIMEE/JMP

WATER FLOW – FIRST PATH

- Water Pump
 - Pumps water in the cooling water system
 - Discharge pressure –approx 25 to 35 psi.
 - Its outlet has three branch lines.
- First branch line
 - To TSC through a flexible pipe
 - Cools
 - Intermediate casing,
 - Bearing on both side of the rotor and
 - Turbine casing.
 - Water returns to the inlet side of the pump.
 - Not required in locos fitted with AIR COOLED TSCs.



SECOND PATH

- Leads to left bank of the engine block
 - One branch pipe to after cooler
 - Conventional WDM2 locos
 - Enters the engine block for cooling
 - Cylinder liners &
 - Cylinder heads.
 - Gets collected in a common header
- From Header proceeds to the right side radiator core.
- Outlet of this core is connected to suction of water pump
- **One branch enters the after cooler.**
 - **For cooling the charge air**
 - **Only in New Generation FE Locos).**



THIRD PATH

- Enters the right side in Engine block to cool
 - Cylinder liners,
 - Cylinder heads
 - Gets collected in a common header
- Outlet of header enters left Radiator core for cooling itself.
- Before it enters the radiator,
 - Connection is taken to the water temperature manifold
 - Temperature gauge is fitted to indicate the water temperature.
 - Four temperature switches are also provided:
- Cooling water from Left radiator
 - Passes through the Lube oil cooler
 - Enters the suction side of water pump.



COOLING WATER TREATMENT

- Water may contain many impurities.
- These impurities may form scales on the heat exchanger surface leading to:
 - Reduced heat transfer coefficient
 - Accelerated corrosion
 - Sludge deposition.
 - At the low pressure zone and
 - Choke the circulation passage.
 - Failure of Engine components.

WHY TO USE CORROSION INHIBITORS?

- Large amount of heat is generated in the diesel engine of locomotives.
- Water is used as cooling medium for engine components.
- This water develops corrosive action at elevated temperatures.
- Corrosion is very harmful for engine components.
- **To protect engine components from this corrosive effect suitable CORROSION INHIBITOR is used.**

CHROMATE BASED INHIBITORS

- Since inception of ALCO locos in India Chromate based coolants were used for water treatment:
- Composition of chromate compound
 - Sodium chromate---60%
 - Sodium carbonate---30%
 - Potassium Dichromate—5
 - Calgon (Sodium hexameta phosphate)—5%
- Attained pH value in the range of 8.5 to 9.5
- **Discarded being unfriendly to the environment.**

BORON BASED INHIBITORS

- With increase in awareness towards ENVIRONMENTAL POLLUTION , chromate based coolants were discarded and boron base coolants were introduced in late 90s.
- **Type of base Brand name Manufacturer**
- **Borate Nitrate Indion-1344 M/S ION Exchange**
- **Borate Nitrate Nalco-2100 M/S Nalco Ltd.**
- Borate Nitrate treated water contains Boron @642 –ppm.
- Achieved pH in the range of 9.5 to 11.8.
- **Discarded very soon being unfriendly to the environment.**

ALL COOLANTS AT A GLANCE

SN	Particulars	INDION 1344	NALCO 2100	X-GT	POWER KOOL-RR
1	Physical Form	Powder	Liquid	Liquid	Liquid
2	Color	Pink	Red	Fluorescent Yellowish Green	Yellowish Green
3	Initial Top up Quantity	8.2 kgs.	36 lts.	120 lts.	36 lts.
4	Method of Topping	Manual	Mechanized System reqd	Mechanized System reqd.	Mechanized System reqd
5	Topping Flexibility	Any where in shed	Only on platforms.	Only on platforms.	Only on platforms.
6	pH	9.5 to 11.0	9.5 to 10.0	8.5 Maxm.	7.5 to 9.5
7	Concentration of Treated Water in ppm	1250-1400 in terms of NaNO ₂	1850-2150 in terms of NaNO ₂	2000-2150 in terms of NaNO ₂	1000-1400 in terms of Carboxylate

MAINTENANCE OF WATER PUMP

- Any failure of this pump will cause
 - Loss of water circulation
 - Rise in temperature of critical components
 - Increased failure.
- Recently RDSO has changed the drawing and material specification of water pump shaft to Stainless Steel retaining the taper sleeve arrangement to prevent cases of shaft failures.
(Modification Sheet No. MP-MOD-ES-01-13-11 April 2012)

Comparison of Shaft designs

Stainless Steel shaft without

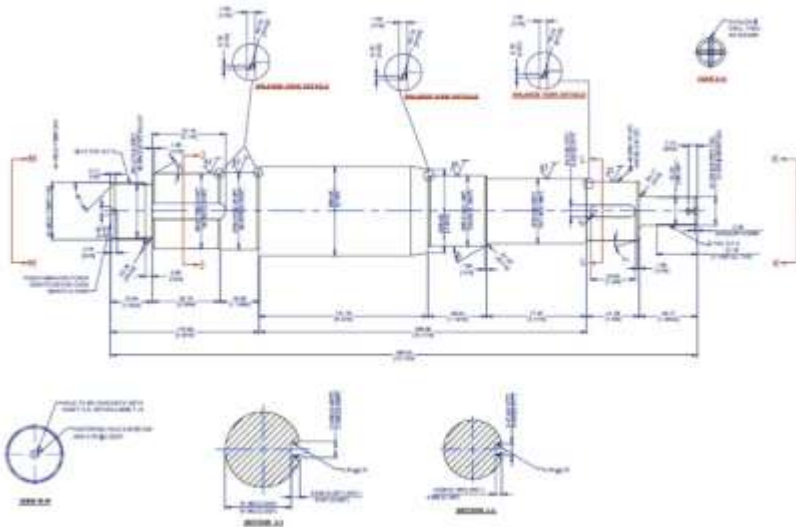

Stainless Steel shaft with taper

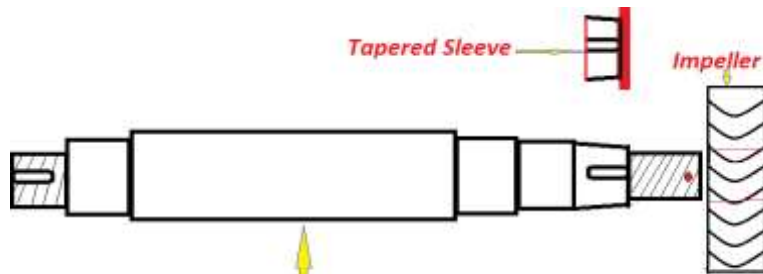
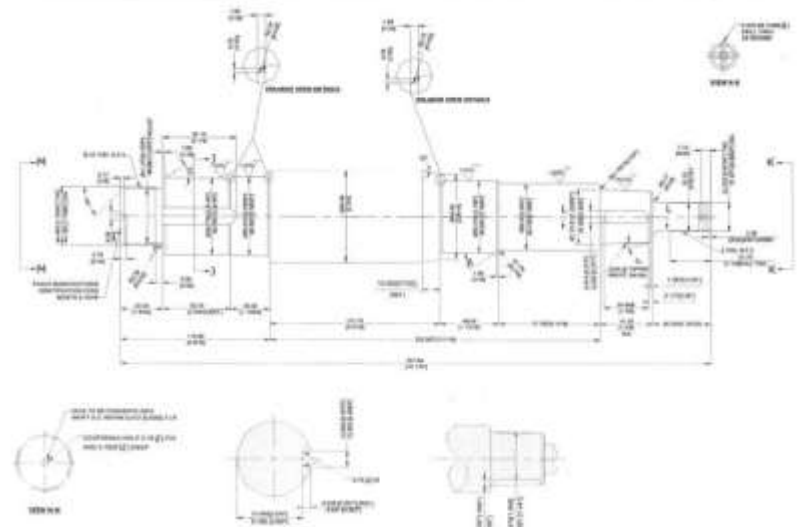

Conventional Water Pump shaft with tapered sleeve arrangement

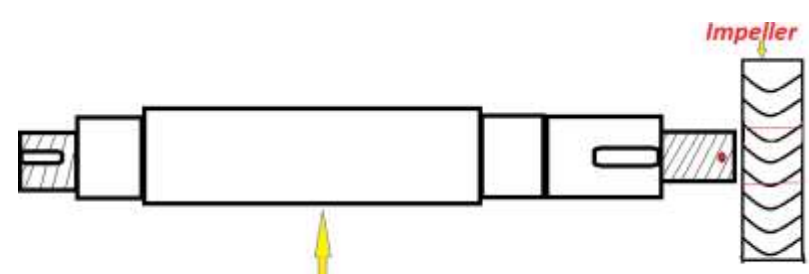

Modified Water Pump shaft without tapered sleeve arrangement

Sectional view- Water Pump



DETAILS OF WATER PUMP

- Overhauling has to be done
 - M24 schedule or
 - Out of course repairs.
- All the gaskets & seals replaced.
- Shaft and impeller
 - Checked for cracks/ defects.
- Gear teeth
 - Checked for any signs of wear / burrs etc.
- Condition of both bearings
 - Checked for excessive sound/ play.

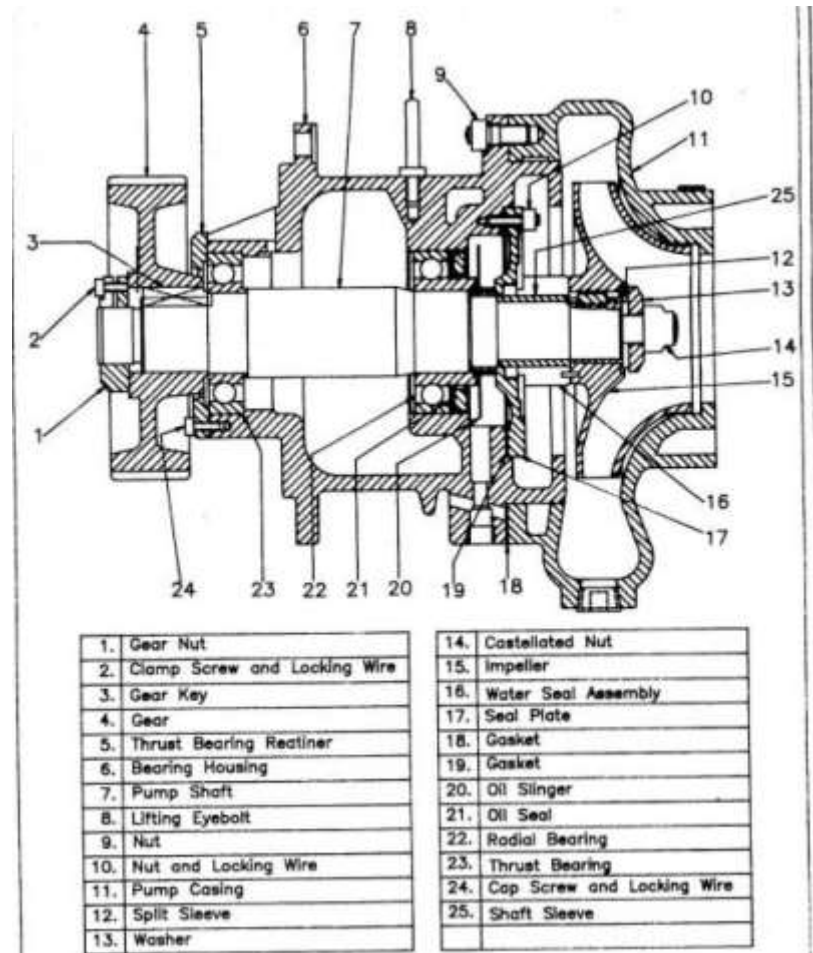

WATER PUMP DETAILS

- Maintain specified interference between impeller and shaft.
- Tighten impeller nut to specified torque value.
- Renew stainless steel split pin every time.
- Check assembled water pump on test bench before fitment on engine.
- Maintain proper backlash during its fitment on engine.

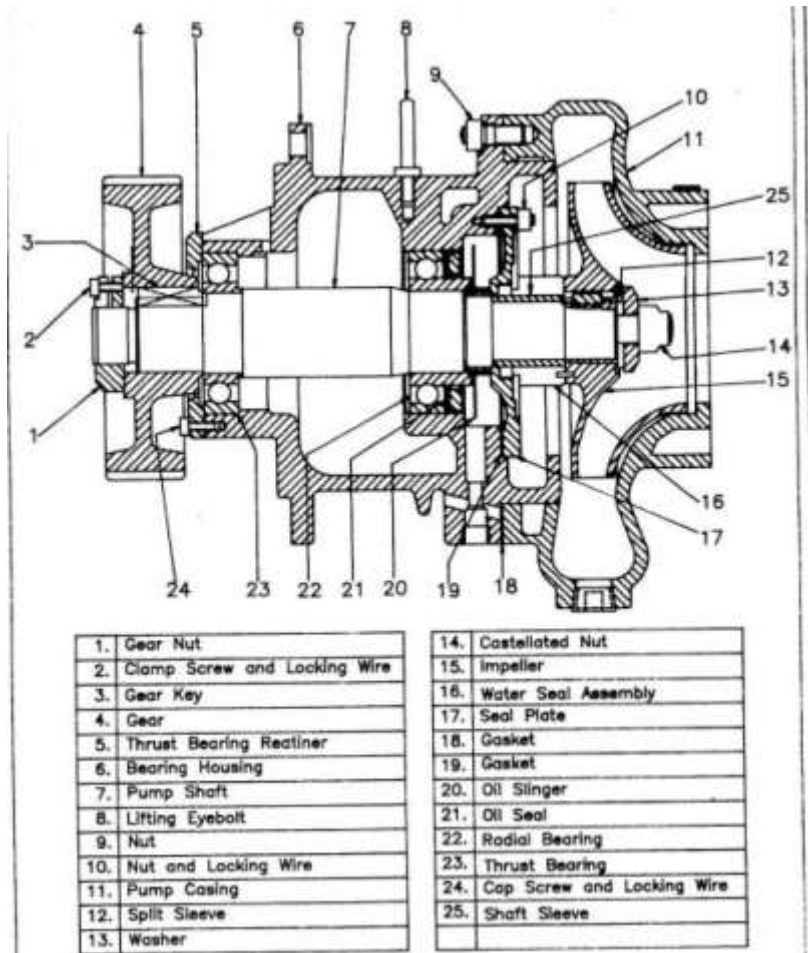

Introduction of larger dia (10") of the impeller

- Original ALCO design of WDM2 water pump had a 9" dia. Impeller. WDM2s faced the problem of overheating of the engine, particularly in the summer months.
- Moreover, the cooling requirement of the engine increased with up-rating to 3100 hp; the impeller dia. was, therefore, increased from 9" to 10". With this modification, the following was achieved:
 - Approx. 30% increase in water flow in the circuit was achieved, resulting in approx. 30% reduction in water temperature rise across after cooler.
 - Approx. 25% more charge air temperature drop across after cooler.
 - Approx. 23.8% reduction in engine water jacket temp. rise.
 - Approx. 5% reduction in water temp. across LO cooler

Increased delivery of Water Pump

Calculation of modified and conventional gear train arrangement:

Gear	Extension shaft	Water pump	Lube oil pump
DLW Part No.	1014487	10140505	10140428
PCD (inches)	15.8	9.2	13.4
PCD (mm)	401.32	233.68	340.36
No. of teeth	79	46	67

DP = PCD in mm / No of teeth
 DP = 401.32 / 79 = 5.08

Pitch circle radius

Extension shaft gear = 7.9"

Water pump gear = 4.6"

Lube oil pump gear = 6.7"

A+B = 29.2"
 A+C = 25.0"

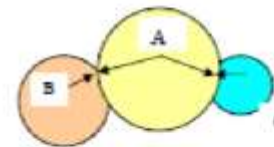

Take pitch circle diameter as:

Gear	P.C Dia (1)	Diametrical Pitch (2)	No of teeth will be (~2X3)
Extension shaft	16.6"	5.08	83
Lube oil pump	12.6"	5.08	63
Water pump	8.4"	5.08	42

Lube oil pump existing rpm - 1180 at engine 1000 rpm as Existing gear ratio: 79: 46

Now modified Gear ratio will be - 83: 42 say 1: 1.976 from 1:1.717, hence the water pump RPM will be 1976 at engine 1000 RPM.

RPM of the pump increased by 15.08 % and

If we take the existing water pump delivery at 1717 rpm as - 600 USG

Then by increasing the pump rpm by 15.08%, the delivery will be 725 USG at engine 1050 RPM.

Water Pump Failure (Case No.1)

Investigation :-

The shaft key slot got damaged due to Cast metal chipped off which subsequently damaged Impeller Key slot, Nut & split pin. As a result Impeller became free.



Water Pump Failure (Case No.2)

Investigation :-

The Water Pump shaft broke into two parts near Impeller side. A blow hole was found at broken face of the shaft. This blow hole has weakened the strength of the shaft at that portion, resulting shaft broken.



Water Pump Failure (Case No.3)

Investigation :-

After dismantling of water pump it was found that the W/P shaft was broken in two parts.



Water Pump Failure (Case No. 4)

It was found that the W/P Impeller is badly worn out and damaged. More over, it was also seen that the Impeller lock nut with washer and split pin had been slipped out. A non permissible clearance has been noticed between new MS Shaft (sleeveless) and old Impeller fitted on it. Due to this clearance, a repeated thrust load by Impeller has been applied on lock nut .Finally, lock nut has been slipped out and impeller started rubbing on housing and damaged it self as well as housing also.



Reinstating lube oil strainer vent pipe

- **I.B. No. MP. IB. ES.09.81.09, November 2009**
- The strainer vent tube is connected at a location in the turbo support that during running of the locomotives it removes fumes / air bubbles along with lube oil.
- This lube oil directly lubricates the extension shaft gear train means it provides an additional lubrication to water pump gear train.
- Various shed are in favour of fitment of the same.
- Some sheds have dummied the strainer vent pipe.
- Due to this reason pitting and scoring marks are observed on the gear train resulting in abnormal sound.
- To overcome the problem this vent tube should be reinstated.

PRESSURIZATION OF COOLING WATER SYSTEM

- Initially the cooling water system was not pressurized.
- Hot engine alarm was set at 84°C.
- There were frequent hot engine cases during summers.
- To reduce water loss due to vaporization idea of increasing the boiling point of water developed.
- By 0.5 kg/cm² pressurization, boiling point has been increased by 11°C.



Fig.-12 Alcoa conventional design pressure cap



Fig.-13 Alcoa conventional design pressure cap assembly

PRESSURE CAP ASSEMBLY

The pressure cap assembly shown in **Fig.2** below, comprises of 2 valves- one operates for releasing the excess pressure and the other operates to destroy the excess vacuum, spring loaded cap, perforated sheet, nitrile rubber gasket & springs. The assembly is secured by a riveted joint at the top. Most of the metallic parts are non ferrous /stainless steel except the M.S. spring loaded cap. A chain is welded with spring loaded cap and bottom plate, to avoid the cap getting misplaced.

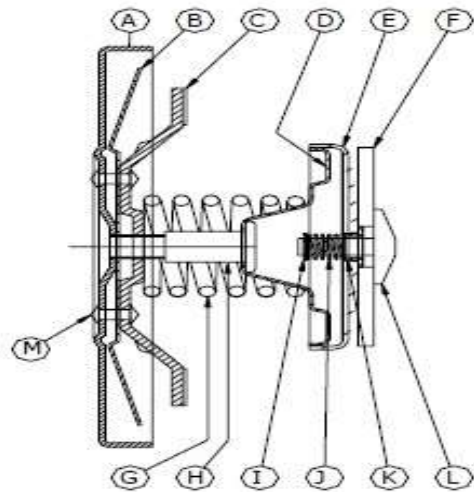

- A –SPRING LOADED CAP
- B –CAP SUPPORTING PLATE
- C –LOCKING PLATE
- D –PERFORATED SHEET
- E - VALVE
- F - GASKET
- G –COMPRESSION SPRING
- H - PIN
- I - CIRCLIP
- J – COMPRESSION SPRING
- K –VALVE BUSH
- L -VACCUM VALVE
- M –SNAP HEAD RIVET

Fig. 2 Pressure Cap Assembly

DEFECTS IN CAP ASSEMBLY

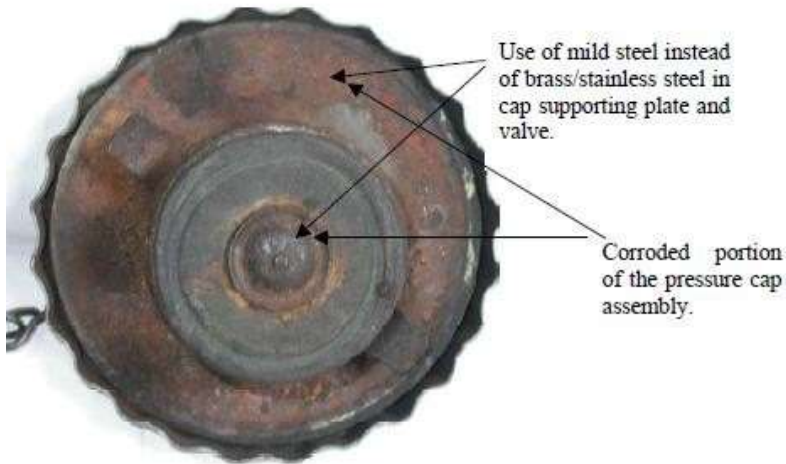

MAINTENANCE OF PRESSURE CAP ASSEMBLY

- The unit maintains pressure in the cooling water system as well as safeguards the working of system due to creation of Vacuum (due to condensation of water vapors) in the system.
 - The function of this pressure cap is to maintain the pressure in the cooling water system in the expansion tank between a value of 0.07 kg/cm² below atmosphere to 0.5 kg/cm² above atmosphere.
- The assembly should be checked visually in quarterly schedules and replaced in M24 schedules as per RDSO instructions.

WATER LEVEL GAUGE

- Provided on the rear expansion tank for checking the level of water in expansion tanks.
- Impurities and corrosion inhibitor present in the water discolors the Perspex sheet cover and it becomes difficult to assess the water level in the tanks.
- The gauge should be checked & reconditioned during M12 schedule.



EMD TYPE GAUGES

- RDSO has advised to change all the conventional glow rod type water level gauges with glass tube type level gauges originally fitted on EMD locos.
- Advantages over glow rod gauge
 - Better visibility,
 - Ease in change of glass tube
 - No need of draining whole water from tank,
 - Less time and man power involvement etc.



Modifications in Cooling Water System

- Mechanically Bonded Radiator Cores.
 - For improved reliability and longer life.
 - Seamless round tubes are mechanically bonded with header.
 - Heat dissipation capacity increased to 1,00,000 BTU/min from 71,000 BTU/min.
- **Higher header plate thickness:** 19mm thick header plate is used in MBR instead of 2.5 mm, which provide uniform flatness and gives proper bonding of the tube with header and help in reducing the leakage through joints.
- **Higher tube thickness of the MBR:** 0.4mm thick HFW tubes used in MBR instead of 0.25 mm thick soldered tube, which is more reliable and less prone to leakage as compared to the soldered tube. HFW tube also provides higher bursting pressure.
- **Higher fin thickness of the MBR:** 0.095mm thick fins are used in MBR instead of 0.06mm thick fins. Higher fin thickness prevents deterioration and distortion of the fin even in the bad climatic condition, thus increases the life of the radiator.
- **Life of the MBR:** The overall life of the MBR is almost three times as compared to the soldered radiator providing more reliable operating conditions.

4.

REVISED ETS SETTINGS

- Enables working temp zone up to 95°C.
- Longer periods of run.

	Previous setting	Revised setting	Working of the ETS
ETS 1	68 °C	68 °C	Pickup of radiator fan contacts to run at slow speed
ETS 2	74 °C	74 °C	Pickup of radiator fan contacts to run at full speed
ETS 3	85 °C	90 °C	Providing audio visual indication of Hot engine indication
ETS 4	--	95 °C	Providing indication of Hot engine indication and engine come to idle

MODIFIED WATER JUMPERS

- For obtaining better leak proof joint even in case of slight misalignment between the engine block and the cylinder head.



WATER LEVEL INDICATORS

- Electronic water level indicator cum switch.
 - Precise and reliable information.
 - To the Driver in the cab itself.
 - Clear status of water level in the expansion tanks.
 - Allowing the crew members to proceed in section with clear idea about water level.
- The normal indicators only indicate in the form of **GREEN, YELLOW & RED** indication and it is not clear as when the level of water will change from **GREEN to YELLOW** or from **YELLOW to RED** zone, leading to loco failure in mid sections.

OTHER CONTRIBUTING FACTORS

- HIGH EFFICIENCY TSCs:
 - Increased BAP.
 - Reduced exhaust gas temperature.
 - Air cooled TSCs do not require cooling water.
- MODIFIED GEAR TRAIN:
 - Gear train modified to increase the RPM (15.08%).
 - Water delivery increased for better heat dissipation.
- High efficiency after coolers.

ACTIONS REQUIRED TO ELIMINATE CASES OF HOT ENGINE

- Radiator Cores:
 - Air blowing in every minor schedule.
 - Should be cleaned both internally and externally.
 - Sealing of radiator doors & panel to prevent drawing of air.
 - **RDSO vide Misc Report No. 223 Aug 2009 have recommended solutions.**
 - For external cleaning ,preferably pressurized hot water steam jet should be adopted to remove traces of oil and dirt sticking to the radiators.

HOT ENGINE PREVENTION

- Cooling Water system:
 - Periodical de-scaling of pipelines.
 - Ensure working of water pressurization system.
 - Chain is provided on caps with suitable clamping arrangement.
- Engine cooling down time:
 - Less than 4 min. for cooling from 85'c to 65'c.
 - May vary slightly depending on conditions.

HOT ENGINE PREVENTION

- Water Pump:
 - Check discharge pressure at 8th notch.
 - It should be 1.8 kg/cm² to 2.5 kg/cm².
- After cooler & Lube oil cooler:
 - Should be removed and cleaned thoroughly after prescribed schedule intervals.
 - No. of dummy tubes should be within limits.
 - After cooler efficiency should be more than 60%.
- Traction Gen & Electrical Components:
 - Thorough air blowing with dry compressed air.

HOT ENGINE PREVENTION

- Radiator fan and ECC:
 - RPM of the radiator should be measured.
 - Should not be less than 1150.
 - Replace ECC if RPM is less than 1150.
- Wire mesh car body filters:
 - Cleaning to be done in every sch.
 - Renew at regular intervals.
 - Replace with disposable paper type.

Instruction to drivers in case of hot engine

- Gradually bring throttle handle to 2nd notch.
- Put GF switch OFF on the control panel.
- Notch up the engine gradually to 8th notch and ensure that Radiator fan is running.
- Wait for some time so that engine temperature comes down and the alarm bell stops ringing.
- When engine is cooled down to about 70'c to 75'c, put GF switch ON and work the engine as usual.

Necessity for safeguard against water pump failures

- In case of water Pump failure
 - No indication is provided in Driver cab room.
 - Power pack gets over heated.
 - Hot engine indication system gets non-functional.
 - Cooling system also gets ineffective.
 - Cylinder heads get cracked
 - Water gets heated up due to convection.
 - Water is thrown out from expansion tank.

Consequence of water pump failure

- Cylinder heads crack due to overheating
- Lube oil temperature gets elevated.
- Temperature of bushes & bearing gets elevated
 - Their normal service life affected.
- Flexible pipe line & rubber gasket's
 - Get affected
 - Vulnerable to failures in near future if not changed.
- Chances of seizure of piston, piston ring & liners.

Modification for engine shut down after water pump failure

- A modification is to be done in water system to avoid the consequent failure of power pack.
- Loco gets shut down with help of this modification after failure of water pump.

INVOLVED CIRCUIT DIAGRAM

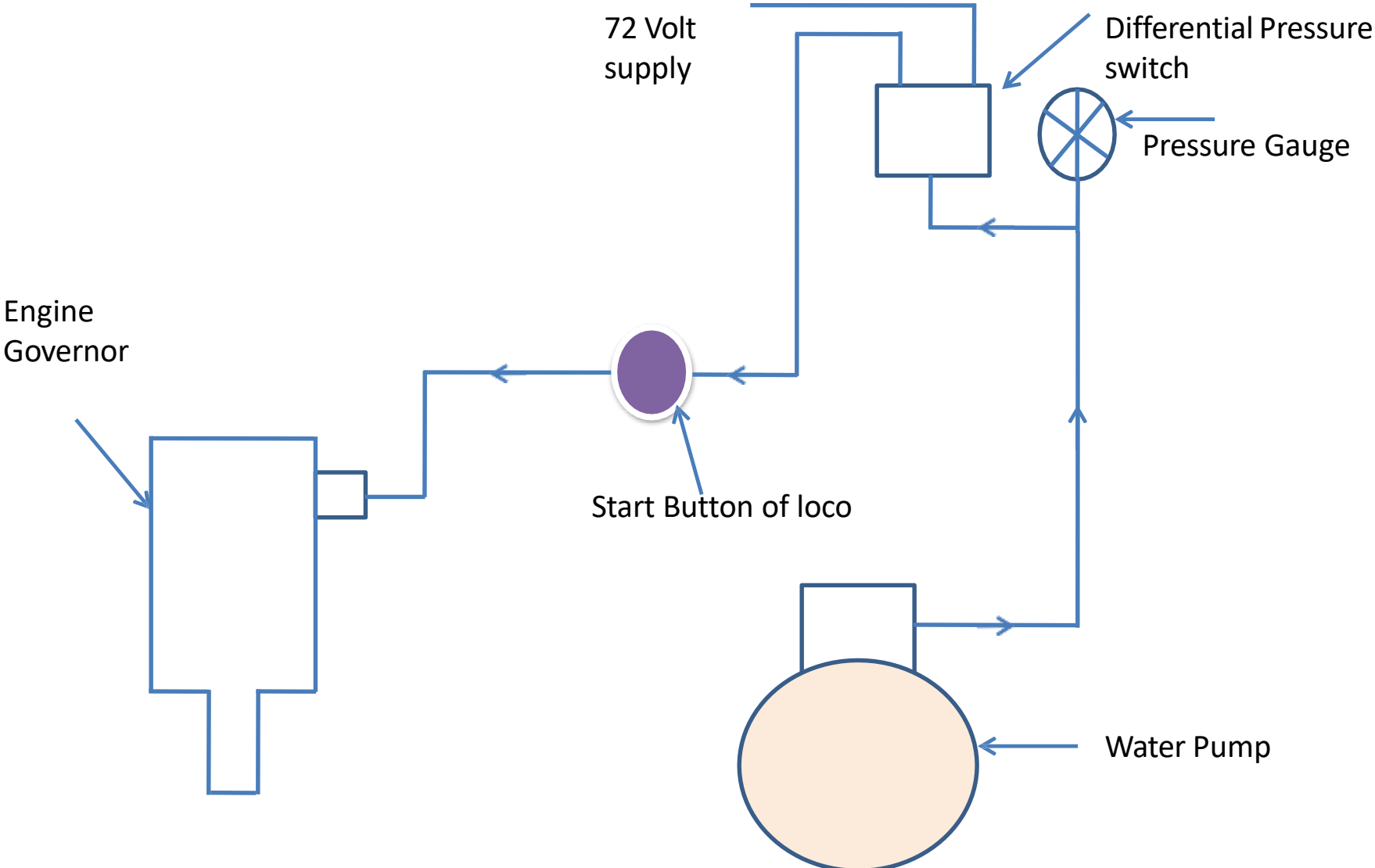

PRESSURE SETTING

- Picking up at -0.1 kg/cm^2
- Dropping at -0.4 kg/cm^2
- Range of differential pressure gauge: $0.1 - 0.4 \text{ kg/cm}^2$

EXISTING ARRANGEMENT

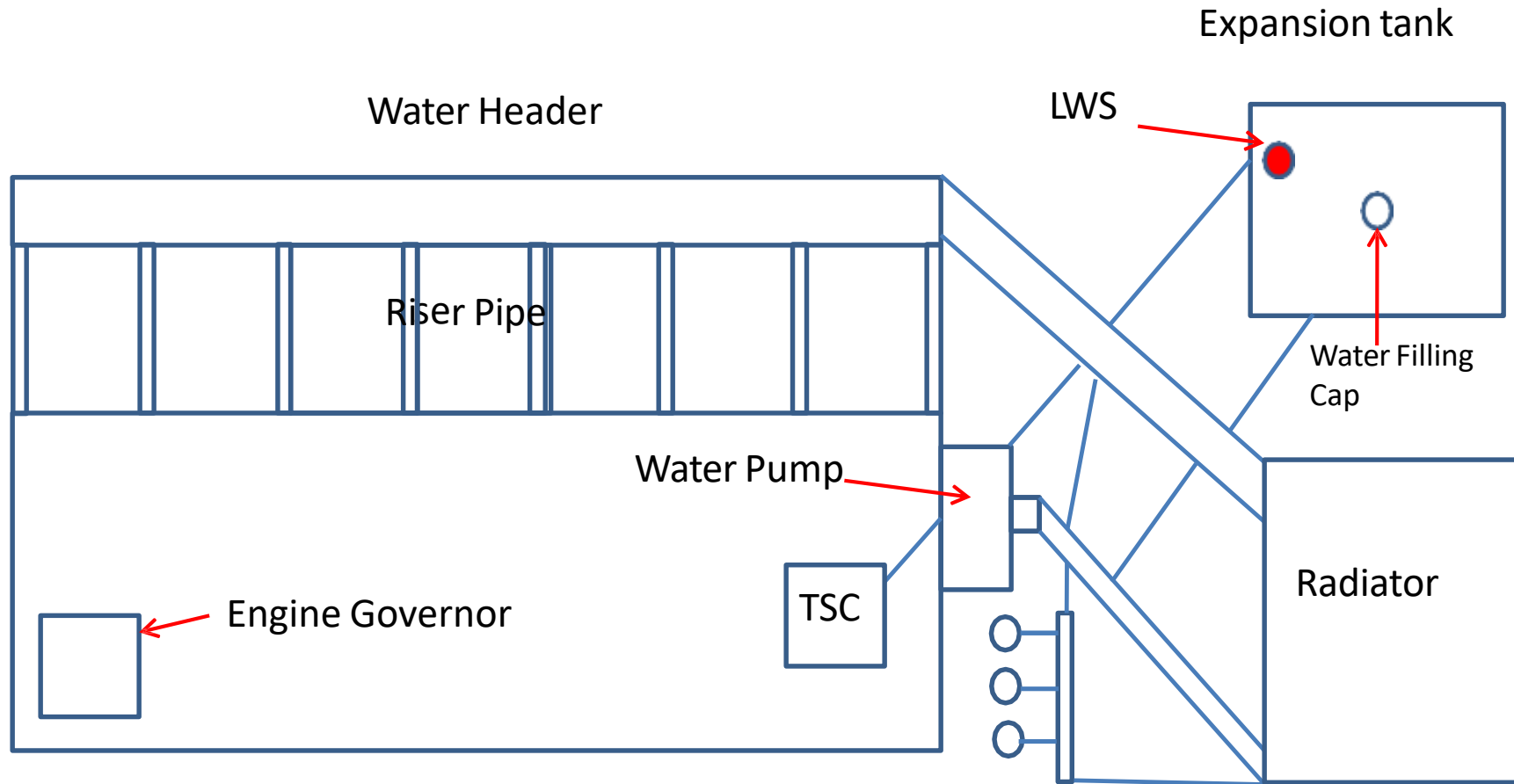

MODIFIED ARRANGEMENT

1. Pressure Gauge

2. Differential Pressure Switch

1 3. Start Button

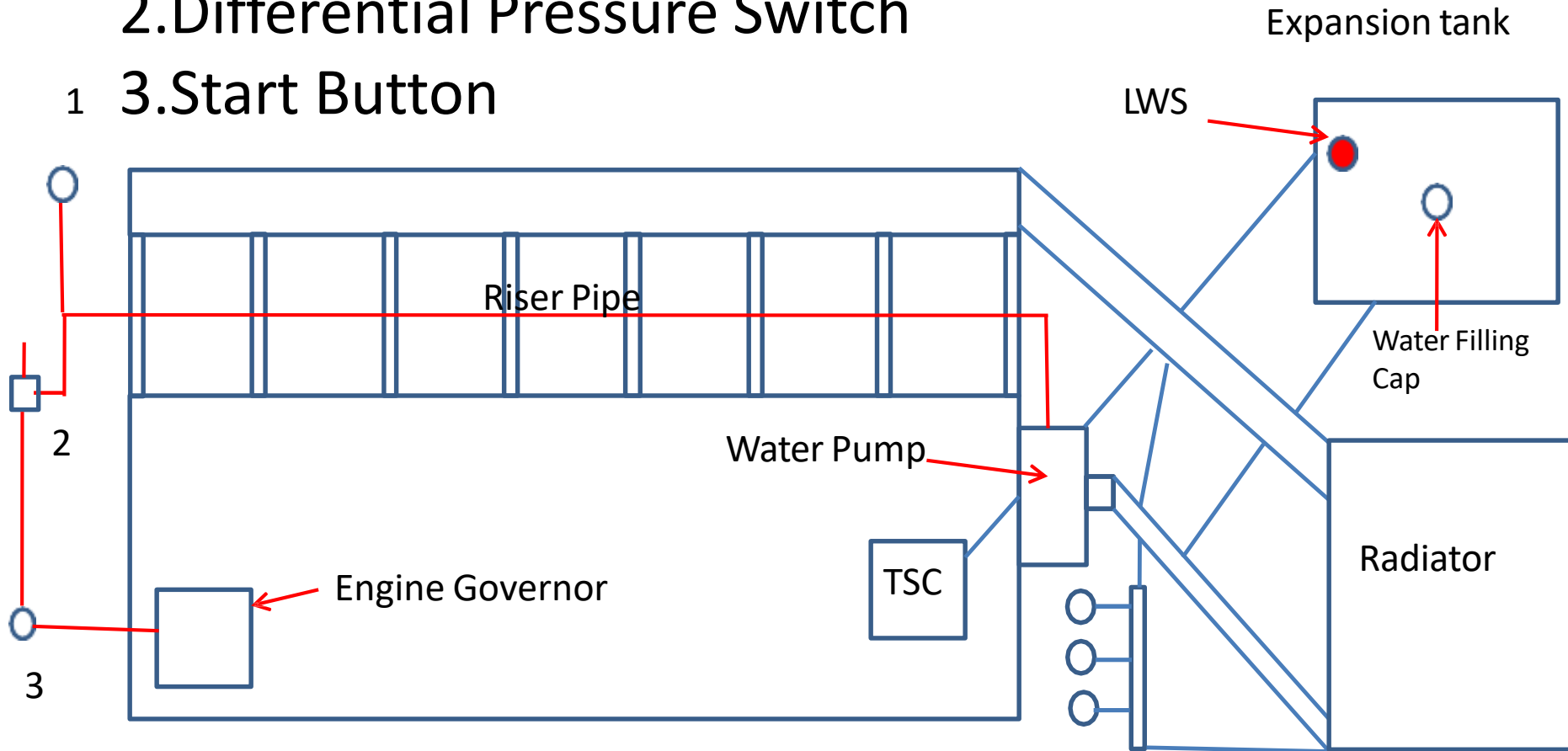

SAFEGUARD IN MEP LOCOS

- Logarithm for ALCO Locos
 - Modification sheet No. MP-MOD-EC-08-58-10 Rev 01
 - For protection of engine by taking inputs
 - Outlet pressure of water pump,
 - Rate of rise of Engine Oil Temperature and
 - Working of sensors (EOT/EWT).
- To be implemented on all locos fitted with micro processor control system at the earliest in association with OEM.

ANALOG OF MEP LOCOS

Sn	WP Pr. (kg/cm ²) at idle	EWT Sensor and check for rate of rise of EWT>90°C for 3 minutes	EOT Sensor and Check for Rate of rise of EOT >100°C for 3 minutes	Action	Display and Fault Logging
1.	≥0.4	Healthy	Healthy	Normal Run	-
2.	≥0.4	Faulty	Healthy	Normal Run	EWT sensor faulty
3.	≥0.4	Healthy	Faulty	Normal Run	EOT sensor faulty
4.	≥0.4	Faulty	Faulty	Normal Run. Turn on R1 and R2	EWT & EOT sensor faulty*
5.	<0.4 #	Healthy	Healthy	Normal Run	Low Water Pressure.
6.	<0.4 #	Faulty	Healthy and temp. ≥3°C	Engine Shut down	Low Water Level or water pump faulty & EWT sensor faulty
7.	<0.4 #	Faulty	Healthy and temp. <3°C & LWS is low	Engine Shut down	Low Water Level or water pump faulty & EWT sensor faulty
8.	<0.4 #	Faulty	Healthy and temp. <3°C & LWS is High	Normal Run	EWT sensor faulty
9.	<0.4 #	Healthy and temp. ≥2°C	Healthy	Engine Shut down	Low Water Level or water pump faulty
10.	<0.4 #	Healthy and temp. <2°C	Healthy & LWS is Low	Engine Shut down	Low Water Level or water pump faulty
11.	<0.4 #	Healthy and temp. <2°C	Healthy & LWS is High	Normal Run	-
12.	<0.4 #	Healthy	Faulty	Engine Shut down	Low Water Level or water pump faulty & EOT sensor faulty
13.	<0.4 #	Faulty	Faulty	Engine Shut down	Low Water Level or water pump faulty & EOT sensor faulty
14.	<0.4 #	EWT≥95°C	Healthy	Engine Shut down	Low Water Level/ water pump faulty
15.	<0.4 #	Faulty/Healthy	EOT >111°C	Engine Shut down	Low Water Level/ water pump faulty

Water pump pr.<0.4 kg/cm² at idle for 20 sec.

* 'Hot engine' situation will not be declared, although water & lube oil temp. may be high. However, eventually engine will be shut down due to LLOP.

Position of Water Pump Shaft failures

(Jan to Dec 2012)

Table-2
NATURE OF DEFECT RAILWAY WISE FAILURE ANALYSIS FOR ALCo LOCOMOTIVES
(January to December 2012)

Description	LH	241	189	245	281	125	189	173	286	89	389	83	267	159	91	185	230	3222
	4digitcode	CR	ECoR	ECR	ER	NCR	NER	NFR	NR	NWR	SCR	SECR	SER	SR	SWR	WCR	WR	Total
Traction motor- failure/defect of bearing (PEB)	6216	3	0	3	3	0	2	0	3	0	7	0	1	3	2	1	1	29
Misc. defect in (AC FPM) inverter unit	7349	3	0	1	0	0	1	0	1	1	0	0	2	5	2	3	8	27
Fuel oil jumper pipe joints leaking/bolts broken	2432	0	0	2	1	1	3	0	0	0	3	3	2	2	0	1	6	24
WP impeller loose on shaft due to key-way damage or impeller worked out due to sleeve loosen	2716	3	1	3	0	1	1	2	0	3	0	0	0	0	0	1	3	18
Radiator element tubes cracked /leaking	2731	3	0	0	1	0	3	0	0	1	0	1	0	1	0	3	3	16
Failure of TM armature winding	6212	2	0	0	2	0	0	3	1	5	0	0	0	0	0	1	2	16
After-cooler tubes cracked/broken	2311	1	0	2	1	0	1	0	0	2	2	0	1	1	1	0	2	14
Water pump shaft cracked/broken/failed	2711	1	0	0	0	2	7	0	0	0	2	0	0	0	0	1	1	14
High pressure tube cracked	2531	0	0	0	0	0	2	0	2	3	0	0	2	1	0	0	2	12
Misc. defect in MCBG	5849	1	0	1	1	0	0	1	0	0	1	1	0	1	2	1	2	12
High Pressure tube broken from top or bottom cone	2536	0	0	1	2	0	0	0	1	0	1	0	0	0	0	4	2	11
Misc. defect in lube oil piping system	2649	1	0	0	0	0	0	0	0	0	1	1	0	1	0	6	1	11
OST plunger retaining spring nut worked out/OST plunger broken	2563	2	0	0	0	0	0	0	0	2	0	0	2	3	0	1	0	10
Misc. defect in circuit breakers	5749	0	0	0	0	0	2	0	2	2	2	0	0	0	0	1	1	10
Control cables-cable ground, short/open ckt.	6423	1	0	0	0	1	1	0	1	0	0	0	3	1	0	1	1	10
Turbine blades	2232	1	1	0	2	0	1	0	0	0	0	0	0	2	0	1	1	9

Thank You