

**ALCO
LOCOMOTIVE
BOGIES**

BOGIE

- Bogie is a wheeled wagon or trolley.
- In mechanics terms, a bogie is a chassis or framework carrying wheels, attached to a vehicle.
- It can be fixed in place as on a cargo truck, mounted on a swivel, as on a railway carriage or Locomotive.

Bogie serve number of purposes

- To support rail vehicle body.
- To run stably on both straight and curve track.
- To ensure ride comfort by absorbing vibration and minimizing centrifugal forces when the train runs on curve at high speed.
- To minimize generation of track irregularities and rail abrasion.

Key Component of a Bogie

- The Bogie frame itself.
- Suspension to absorb shocks between the bogie frame and the rail vehicle body. Common types of coil springs or rubber Pads.
- At least two wheel set, composed of axle with a bearing and wheel at each end.
- Axle box suspension to absorb shock between the axle bearing and the bogie frame. The axle box suspension usually consists of a spring between the bogie frame and axle bearings to permit up and down movement and sliders to prevent lateral movement.
- Brake equipment, brake shoes are used that are pressed against the tread of wheels(in a specified way).
- Traction motors for transmission on each side.

BOGIE NOMENCLATURE

AAR CLASSIFICATION

- Classification done on the basis of wheel arrangement
- Incorporating the under mentioned particulars.
 - Classification/codification of wheels
 - Arrangement of wheels

CLASSIFICATION OF WHEELS

- Carrying Wheels:
- Only for carrying the weight of locomotive
 - Have no driving power.
 - Denoted by numbers i.e.
 - 1 for one set of carrying wheels,
 - 2 for two set of carrying wheels & so on.

CLASSIFICATION OF WHEELS

- Driving wheels:
- In Addition to carry the weight of locomotive, provide the driving power to the Locomotive

• De

Denote letter	No of wheel-sets
A	1
B	2
C	3

- Sub divided into two heads.
 - Independently driving wheels.
 - Coupled driving wheels.

TYPES OF DRIVING WHEELS

- Independently Driving Wheels:-

- Denoted by adding suffix “o” with the denoting letter i.e.

- Ao - One set
- Bo - Two sets
- Co - Three sets

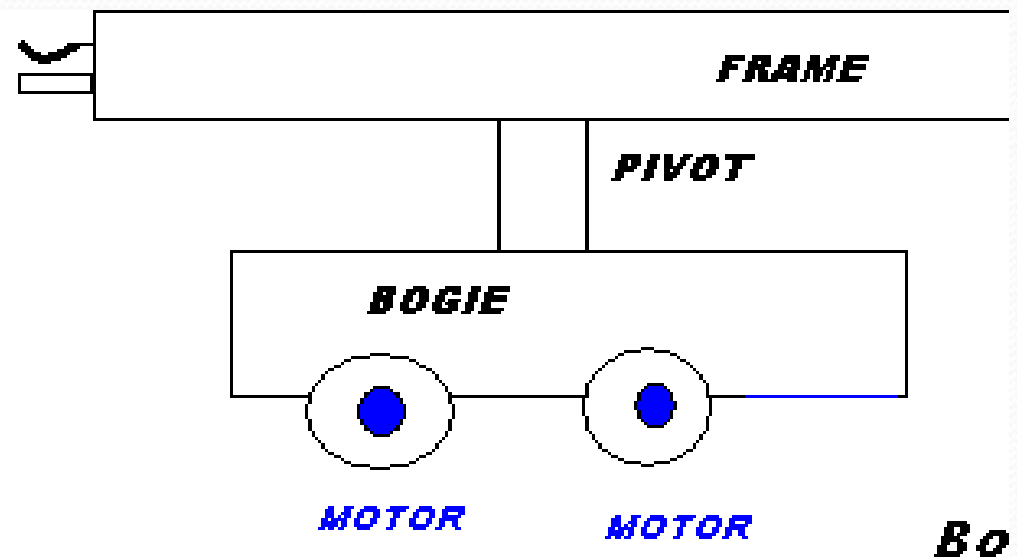

TYPES OF DRIVING WHEELS

- Coupled Driving Wheels : -
- Denoted by comma(',') to the denoting letter i.e.
 - A'- One set
 - B'- Two sets
 - C'- Three sets

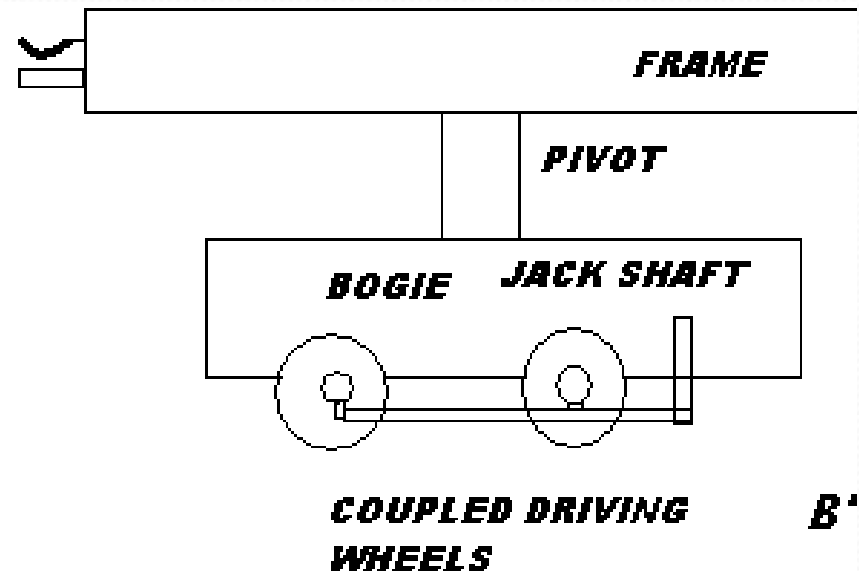

TYPES OF LOCOMOTIVE

- Rigid Frame Locomotive:-
 - Chassis is directly mounted on wheels.
- Bogie Type Locomotive:-
 - Wheels are arranged into bogies,
 - Chassis is mounted on bogies.
 - Provides greater flexibility than rigid frame arrangement for negotiating curves.

TYPES OF LOCOMOTIVE

BOGIE TYPE LOCOMOTIVE

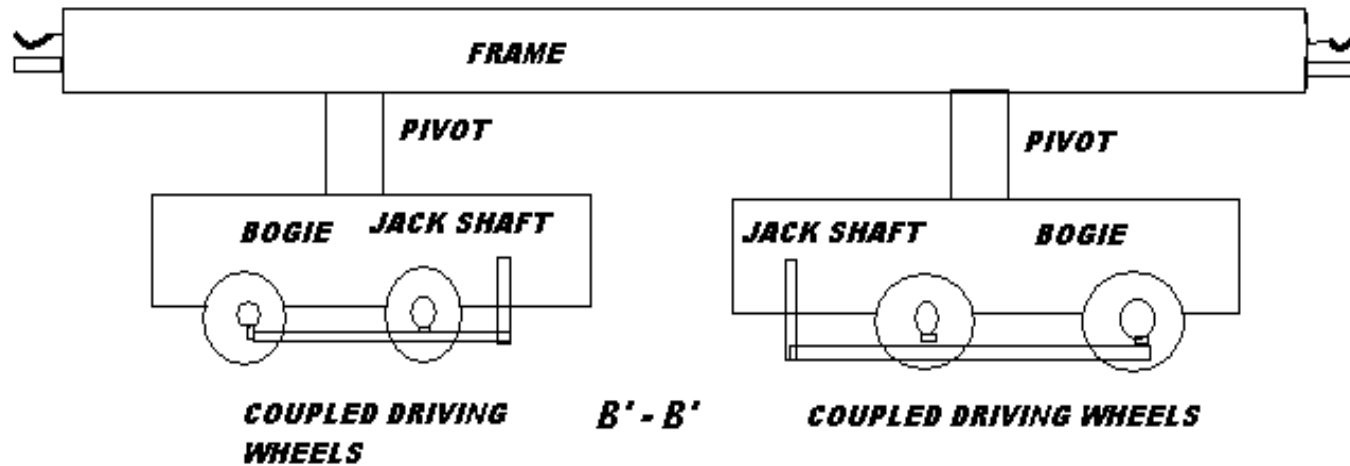

BOGIE TYPE LOCOMOTIVE

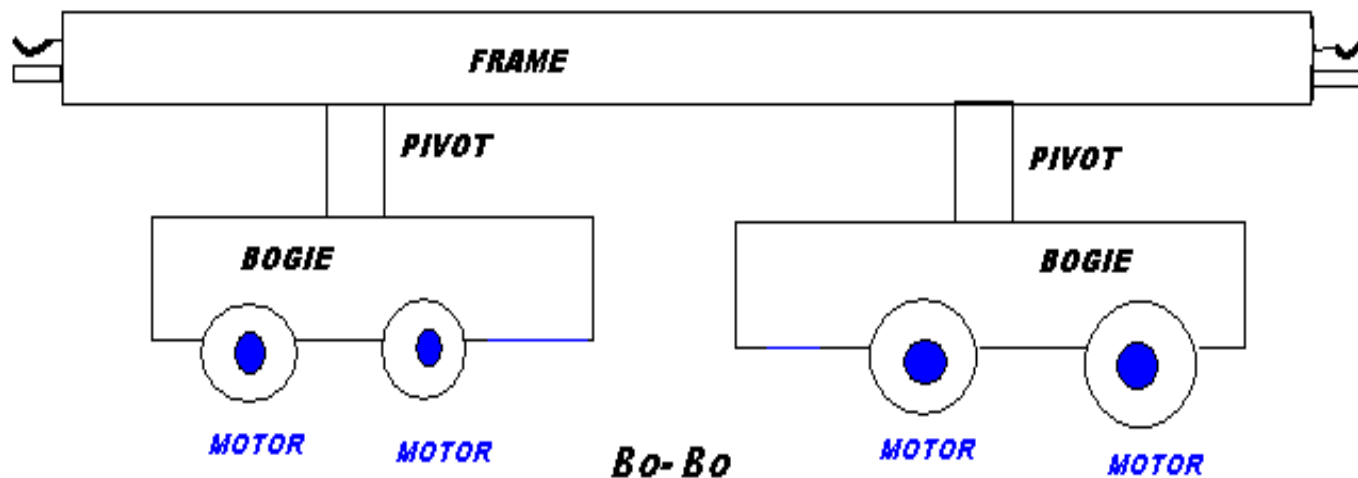

TYPES OF LOCOMOTIVE

BOGIE TYPE LOCOMOTIVE

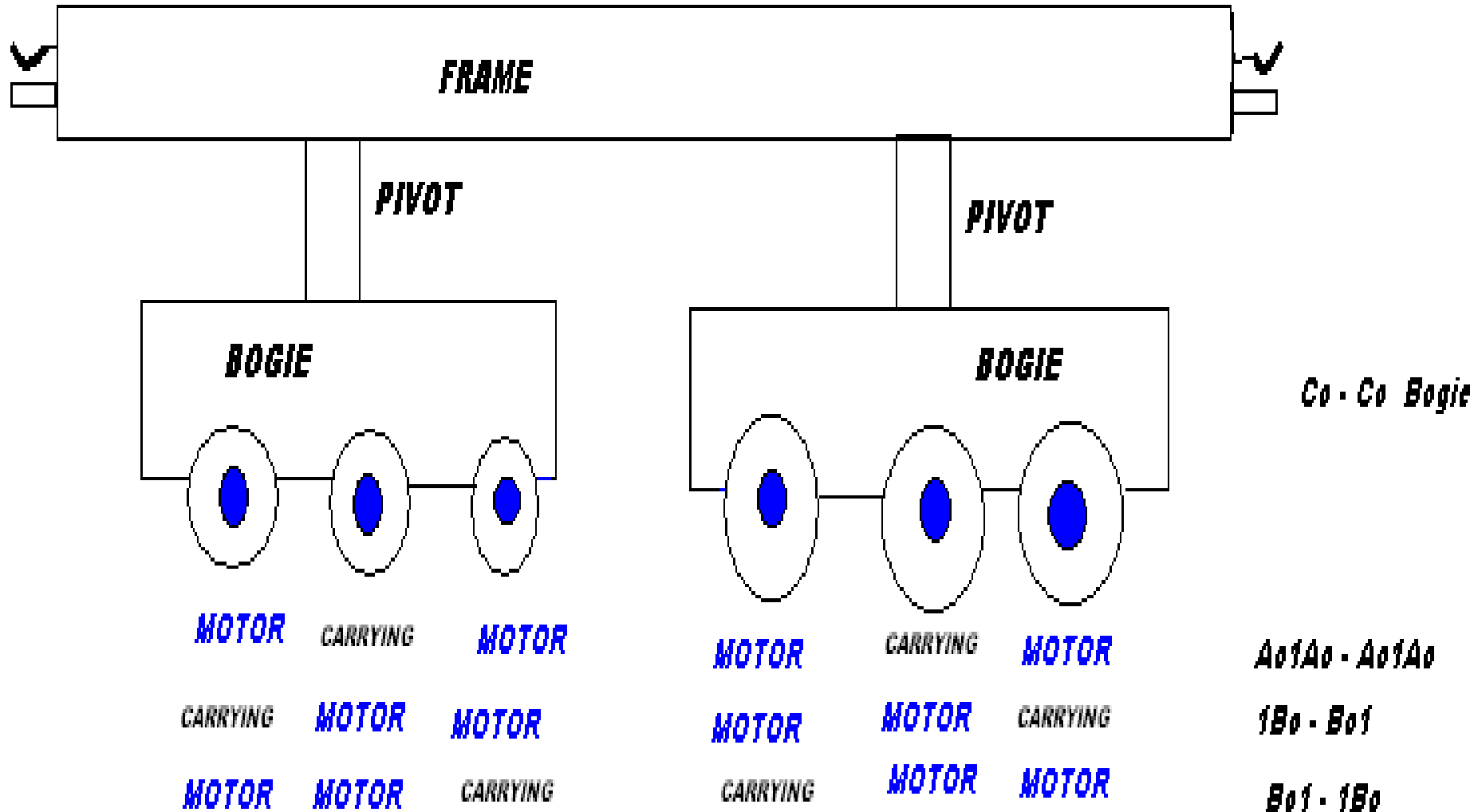

CAST STEEL BOGIES

- ALCO cast steel
 - Co-Co Trimount
 - Co-Co Tetra mount
- Flexi Coil
 - Bo-Bo for WDP1 locos
- HTSC for EMD Locos.

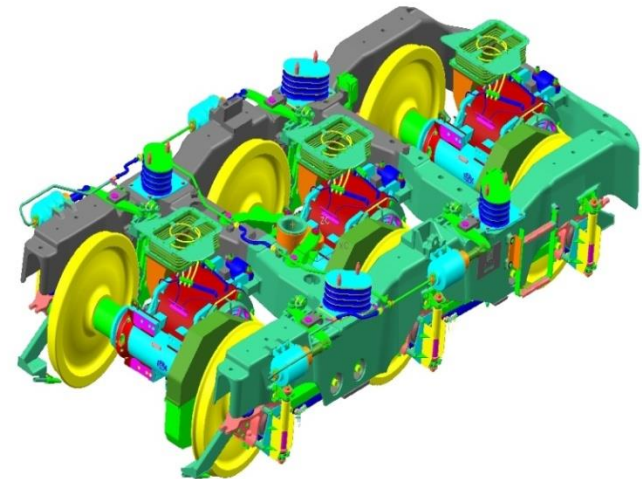

PICTORIAL VIEW OF ALCO(WDM2) TRIMOUNT BOGIE

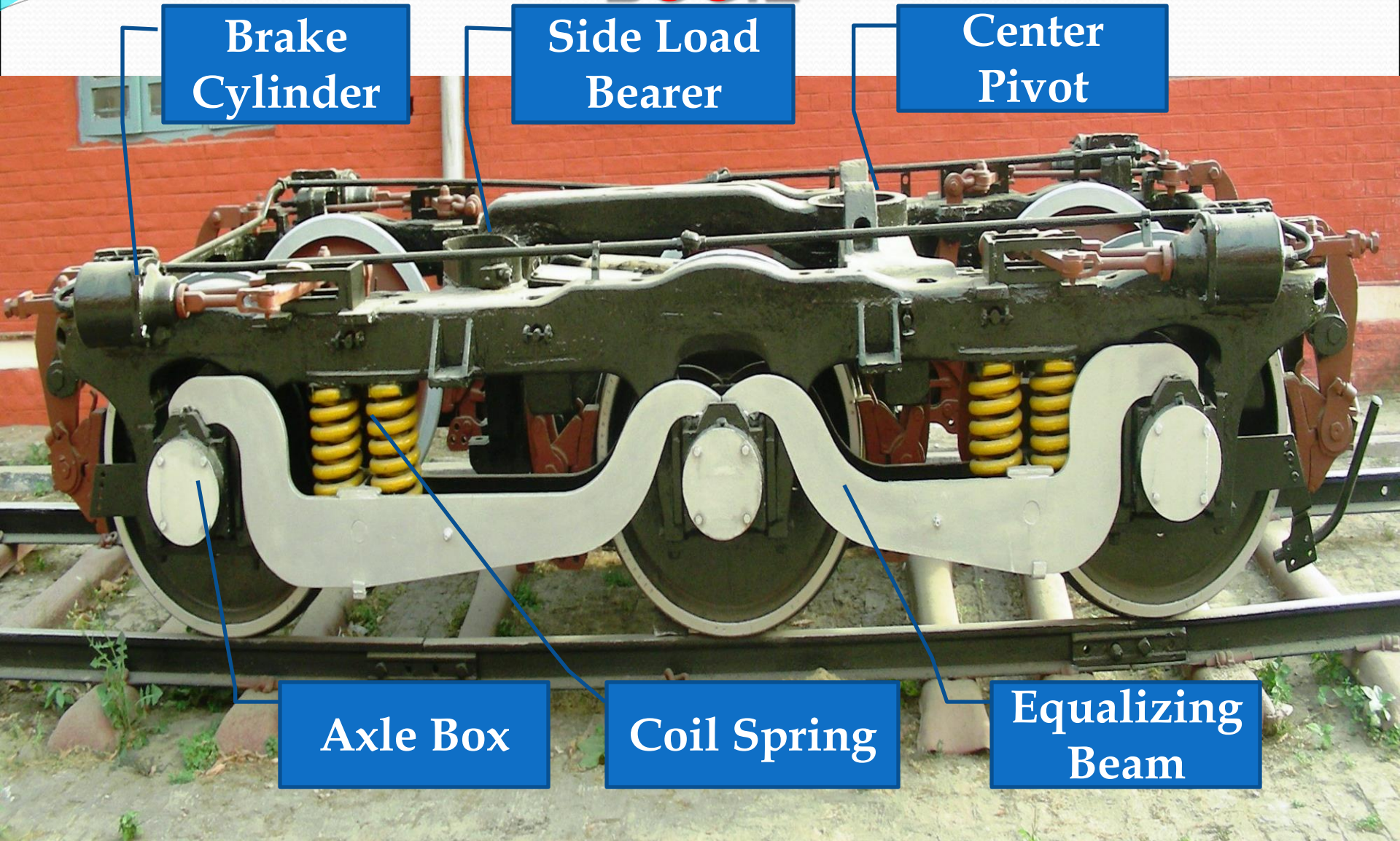

Brake
Cylinder

Side Load
Bearer

Center
Pivot

Axle Box

Coil Spring

Equalizing
Beam

PICTORIAL VIEW OF ALCO(WDM2) TRIMOUNT BOGIE

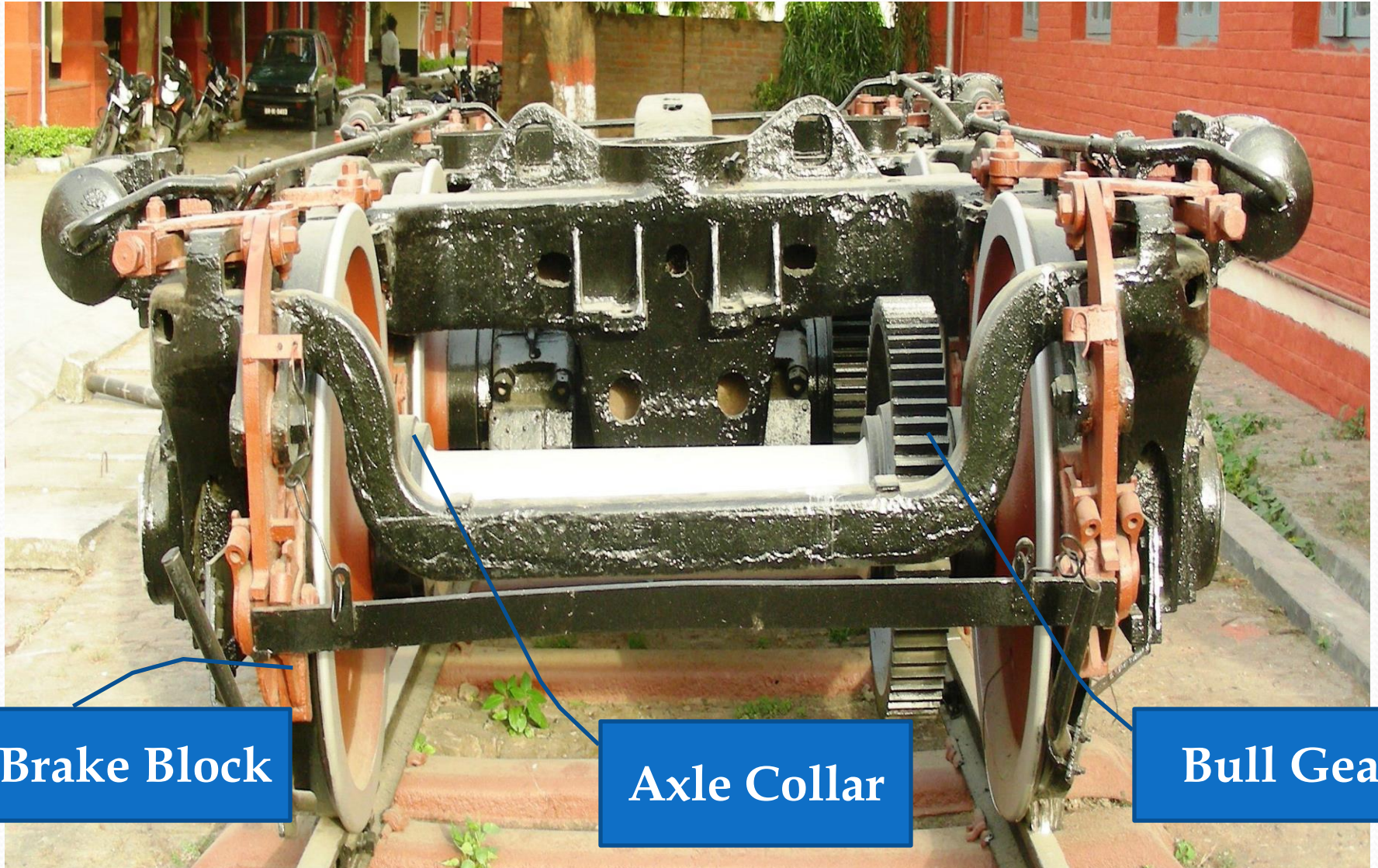

Brake Block

Axle Collar

Bull Gear

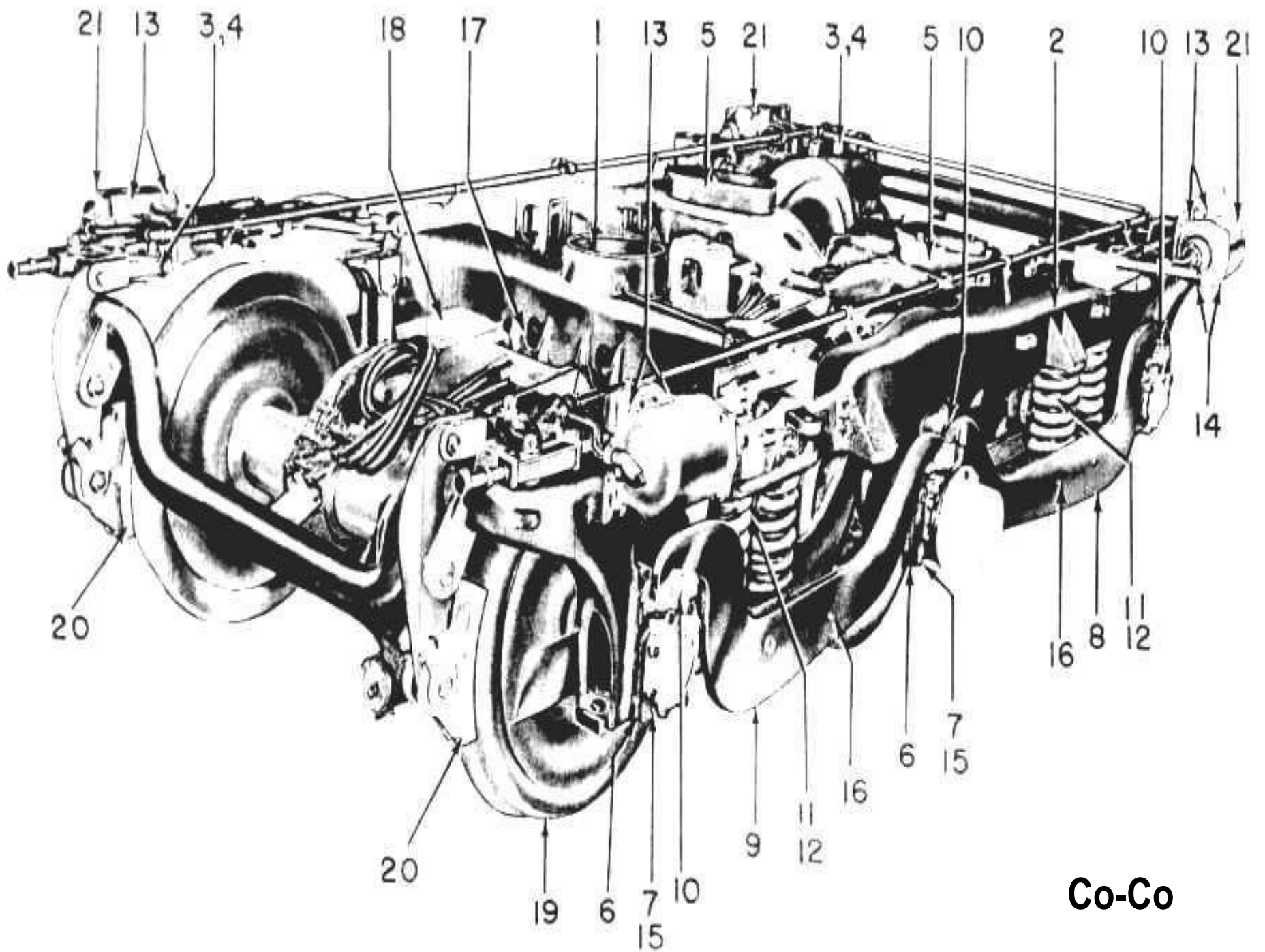

Co-Co

Part list of Bogie

- 1. Bolster wear plate. 2. Frame. 3. Brake cylinder fulcrum.
- 4. Bushing, brake cylinder fulcrum. 5. Loading oil pan.
- 6. Liner, pedestal.
- 7. Pedestal cap. 8. Equalizer, long end.
- 9. Equalizer, short end. 10. Equalizer spring seat.
- 11. Coil spring (Including snubber). 12. Coil spring
(Including nest of two springs).
- 13. Brake cylinder bolts and nut. 14. Brake cylinder stud.
- 15. Bolt pedestal cap to nut. 16. Bolt for equalizer.
- 17. Motor nose suspension. 18. Traction motor air duct.
- 19. Wheel, axle gear & journal box. 20. Brake shoes and heads.
- 21. Brake cylinder.

MAIN SUB-ASSEMBLIES OF BOGIE

- 1- Bogie Frame 2-Axle 3-Wheel 4- Axle Box 5-Bull gear 6-pinion 7- Dust ring 8- Traction Motor 9- Suspension bearing 10- Felt wick lubricator 11- Nose pad 12- Gear case 13- Brake cylinder 14- Brake block 15- Centre pivot 16- Side bearer 17- Equilising beam 18- Friction snubber 19- Friction shoes 20- Helical spring 21- Break pull rod 21- Slack adjuster Top 22- Slack adjuster bottom

CRITICAL SECTION OF BOGIE FRAME

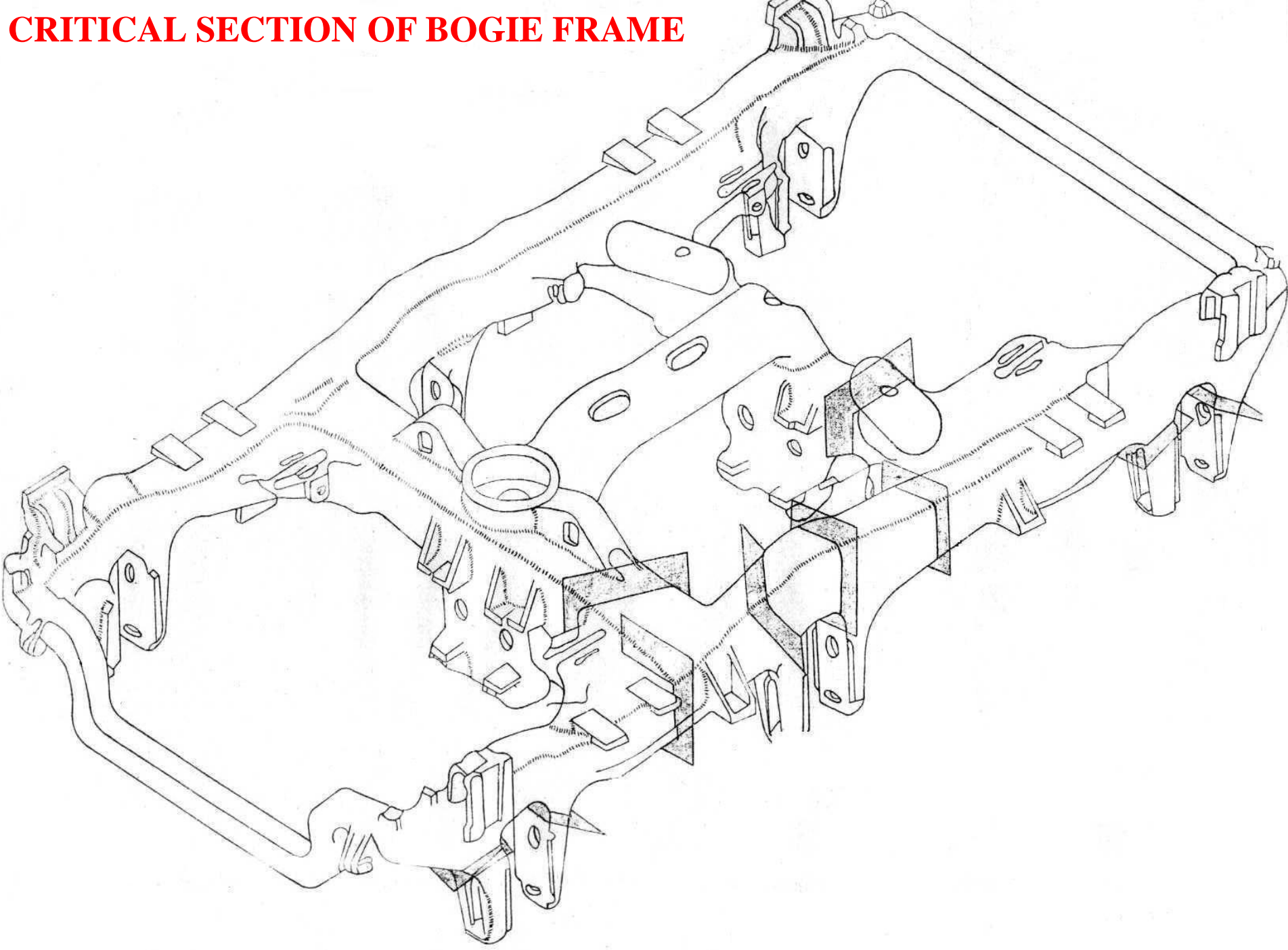

DETAILS OF TRIMOUNT BOGIE

- Single Stage Suspension.
- Three Point Support
- Single piece cast steel frame
- A conventional bogie pivot
 - carried in the cross member located between the leading and middle axles
 - Carries 60% weight
- Two load bearers
 - carried in cross member of the frame between the middle and trailing axles
 - Carries 40% weight@20% each.



BOGIE LOAD TRANSFER

- Three point weight transfer
 - Bogie pivot
 - On cross member between the leading and middle axles.
 - Approximately 60% of the vertical load.
 - Transmits traction and braking forces.
 - Two load bearers
 - In cross member of the frame between the middle and trailing axles.
 - Each carries 20% of the vertical load.



Primary & secondary suspension

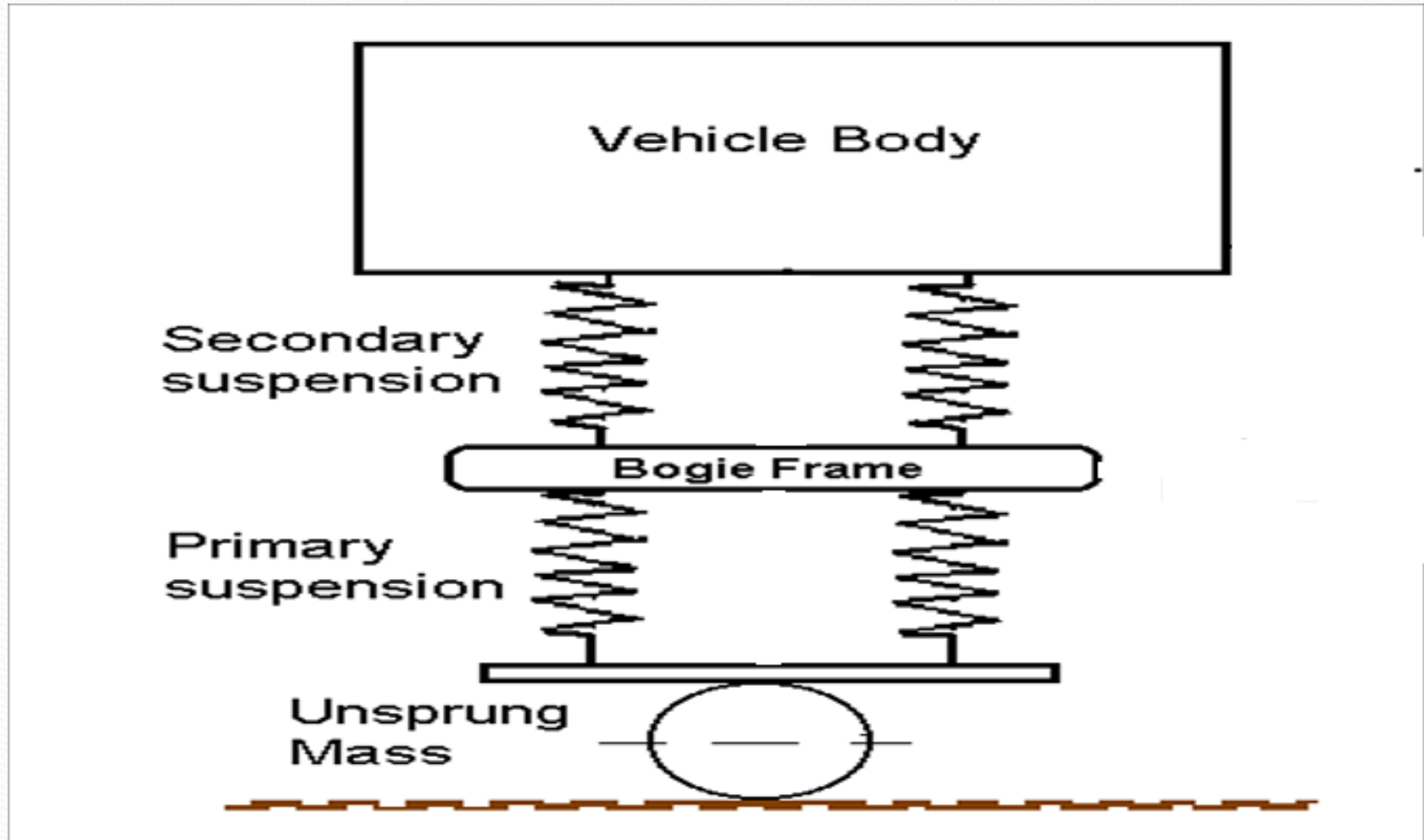

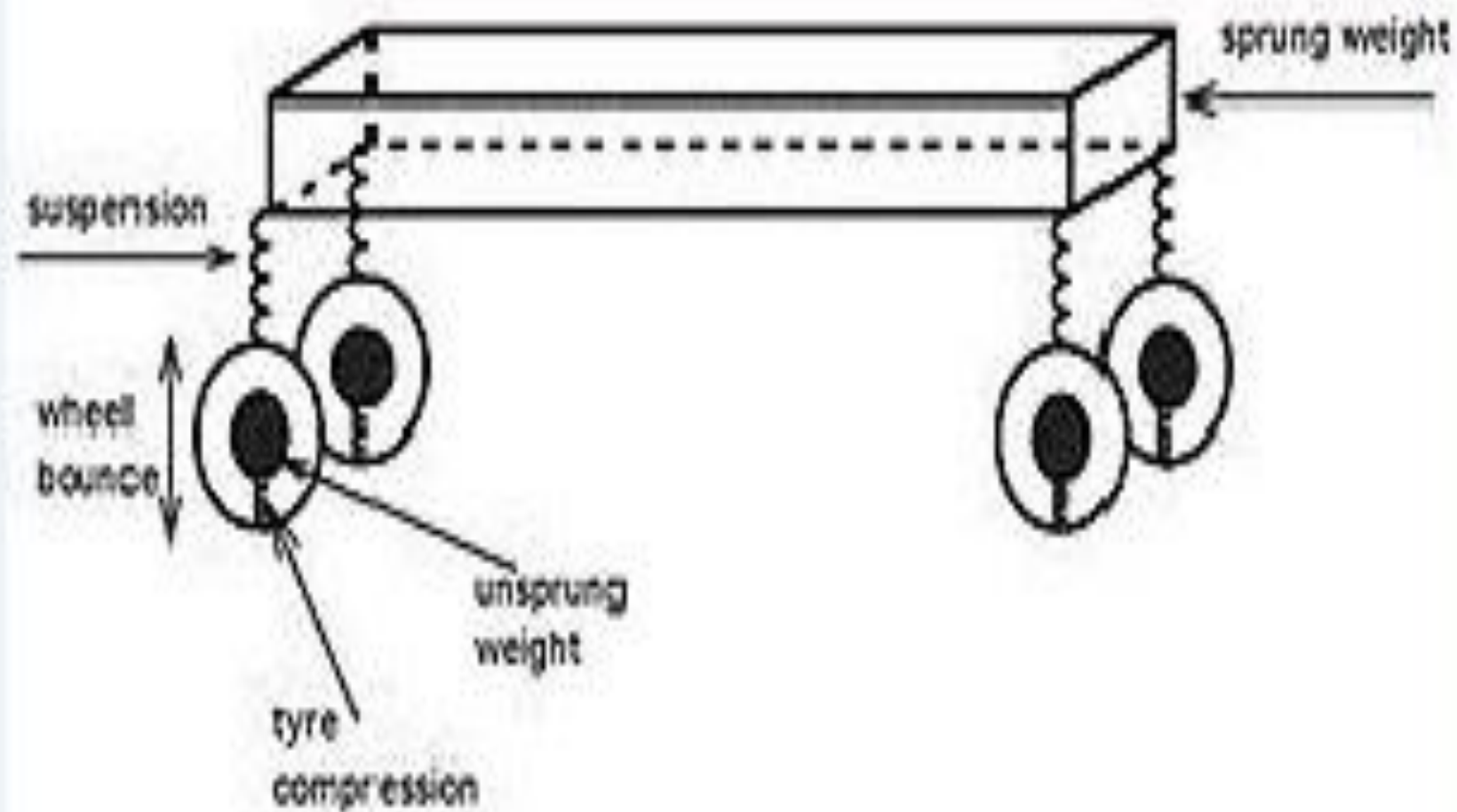

Weight Distribution

- Total weight of locomotive 112.8 Tonnes.
- Weight of two bogies@23 T each 46 T.
- Weight to be born by bogies
T. $(112.8-46)= 66.8$
- Weight born by one bogie $66.8/2= 33.4$ T.
- Weight born by Centre pivot
60% of 33.4
20.04 T.
- Weight born by each side bearer
20% of 33.4
6.68 T.

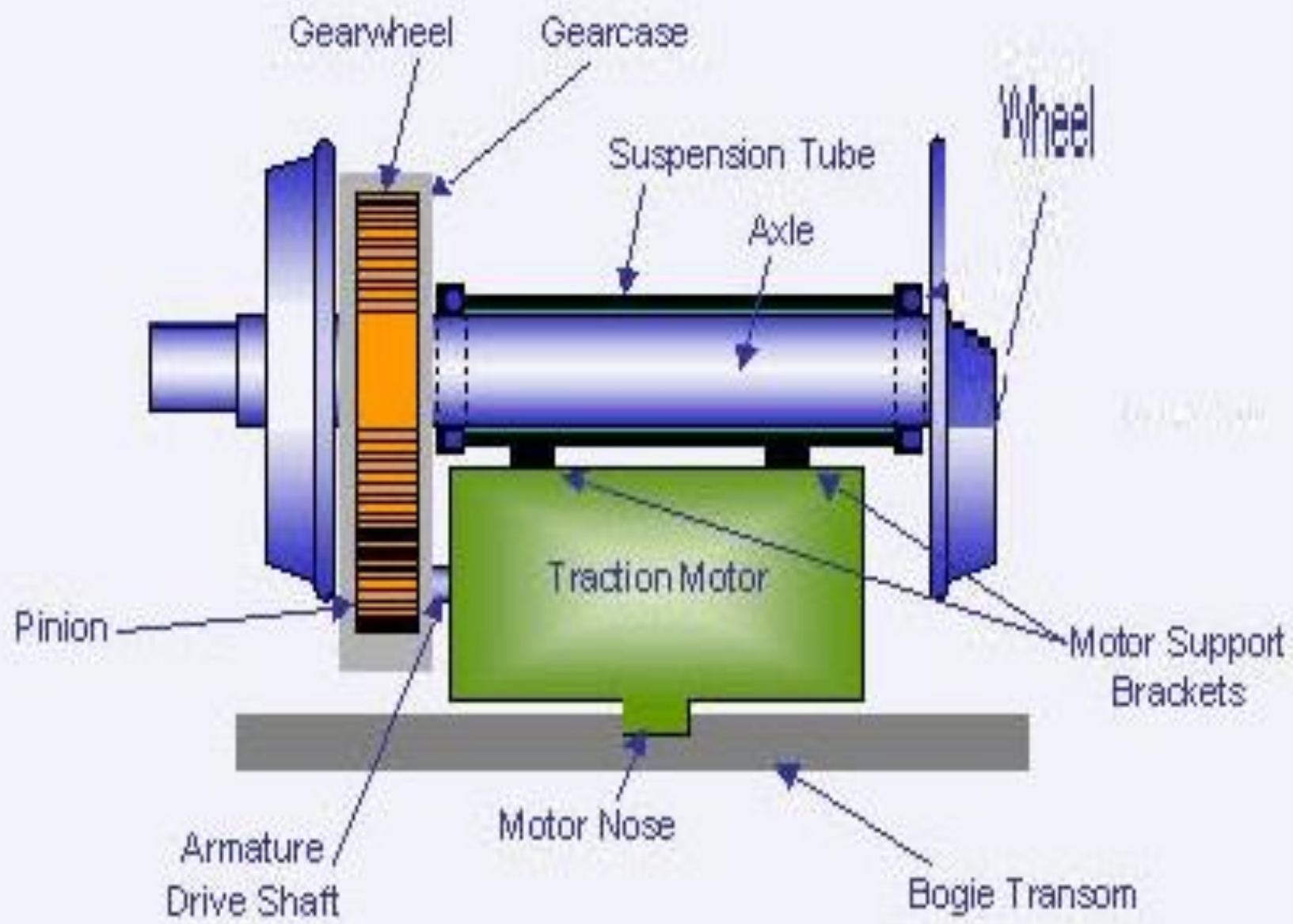

Diagram of DC Nose Suspended Traction Motor

AXLE JOURNAL BOXES

- Actively involved in transmission of traction & braking forces from bogie frame to wheels.
- Lateral & longitudinal clearances are very critical for safe running of locomotive.
- Clearances should not be compromised.



AXLE JOURNAL BOXES

- Actively involved in transmission of traction & braking forces from bogie frame to wheels.
- Lateral & longitudinal clearances are very critical for safe running of locomotive.
- Clearances should not be compromised.



AXLE BOX AND BEARINGS

- There are two types of axle boxes are fitted on WDM₂ locomotives:
- Narrow horn axle box
- Wider horn axle box
- **Narrow horn:** Following make bearings are used in narrow horn type axle boxes.
- **Timken Quad:**
- Timken Quad bearing consists of taper rollers arranged in four rows to take both radial and thrust load.
- Grease is provided time to time to the bearing by grease applicator.

Narrow horn:

- **SKF:**
- SKF axle box bearing is a combination of two separate bearings.
- One four rows cylindrical roller bearing to carry radial loads &.
- Another heavy duty single row deep groove ball bearing to carry thrust loads.
- Grease nipple is provided with box cover for topping up to axle boxes.

Wider horn

- **Wider horn:** Following make bearings are used in wider horn type axle boxes.
 - **Timken AP:**
 - Timken AP bearing consists of taper roller arranged in two rows to take both radial and thrust load.
 - This type of bearing is pre-lubricated and sealed.
- NBC/NORMA :**
- Two nos. bearings are fitted in axle box with spacers. Each bearing consists of single row cylindrical rollers.
 - Lubricating holes are provided on the top of axle box and on the end cover of box for periodic lubrication

GENERAL INFORMATION

- The frame
 - Supported by coil springs on equalizing beams.
 - Four sets of double equalizer beams.
- Equalization of axle load
 - Between adjacent wheels is obtained by suitably positioning the springs on equalizing beam sets.
- Clasp /L type brakes.



Holding Traction Motor with frame



TRACTION MOTOR SUSPENSION BEARING

Two pair suspension bearing is fitted on one axle. Each pair has two portions. One top and one bottom. Suspension bearing is made by anti-friction metal lining.

Plain bearing suspension



UNDER SIZE BEARINGS

- The use of under size bearings becomes necessary when the journals get scored and require machining and grinding. The recommended undersize for axle journals are as follows:

- Standard - $9.000'' \pm 0.002''$
- Step size - $8.938'' \pm 0.002''$
- Step size - $8.875'' \pm 0.002''$
- Step size - $8.813'' \pm 0.002''$

DATA ON SUSPENSION BEARINGS

- Type of bearing - High quality bronze with anti friction metal lining.
- Number required per motor - Two pair
- Inside box dimensions
- **Standard size** - **9.016"**
- **Under size** 1st. - **8.954"**
- 2nd. - **8.891"**
- 3rd. - **8.829"**
- 4. End play - total Minimum - **0.0625"**
- Maximum - **0.3125"**
-

DATA ON SUSPENSION BEARINGS

- 5. Radial clearance Minimum - 0.014"
- Maximum - 0.060"
- 6. Collar thickness Minimum - 1.031"
- 7. Maximum permissible wear collar - 0.125"
- 8. Torque value for bearing cap bolts - 759-810 ft. lbs.
-

FELT WICK LUBRICATOR

- Lubrication of traction motor suspension bearings is provided by felt wick inserted in the oil reservoir in each bearing cap, which ensure that the quantity of oil required for the lubrication of bearing as available continuously.
- The oil is drawn up from the oil reservoir to the bearing by capillary attraction in the strands of the felt and it is therefore essential for proper lubrication to provide a continuous path for the oil flow. For the proper lubrication of suspension bearings it is good normal practice that felt wicks are maintained at satisfactory level.

The felt wick assembly has two critical components.

- Felt wick
- Positioning spring
- **MAIN PARTS OF FELT WICK LUBRICATOR**
- Wick assembly
- Wick positioning springs
- Spring support
- Spring support pin
- Carrier plate
- Cutter pin

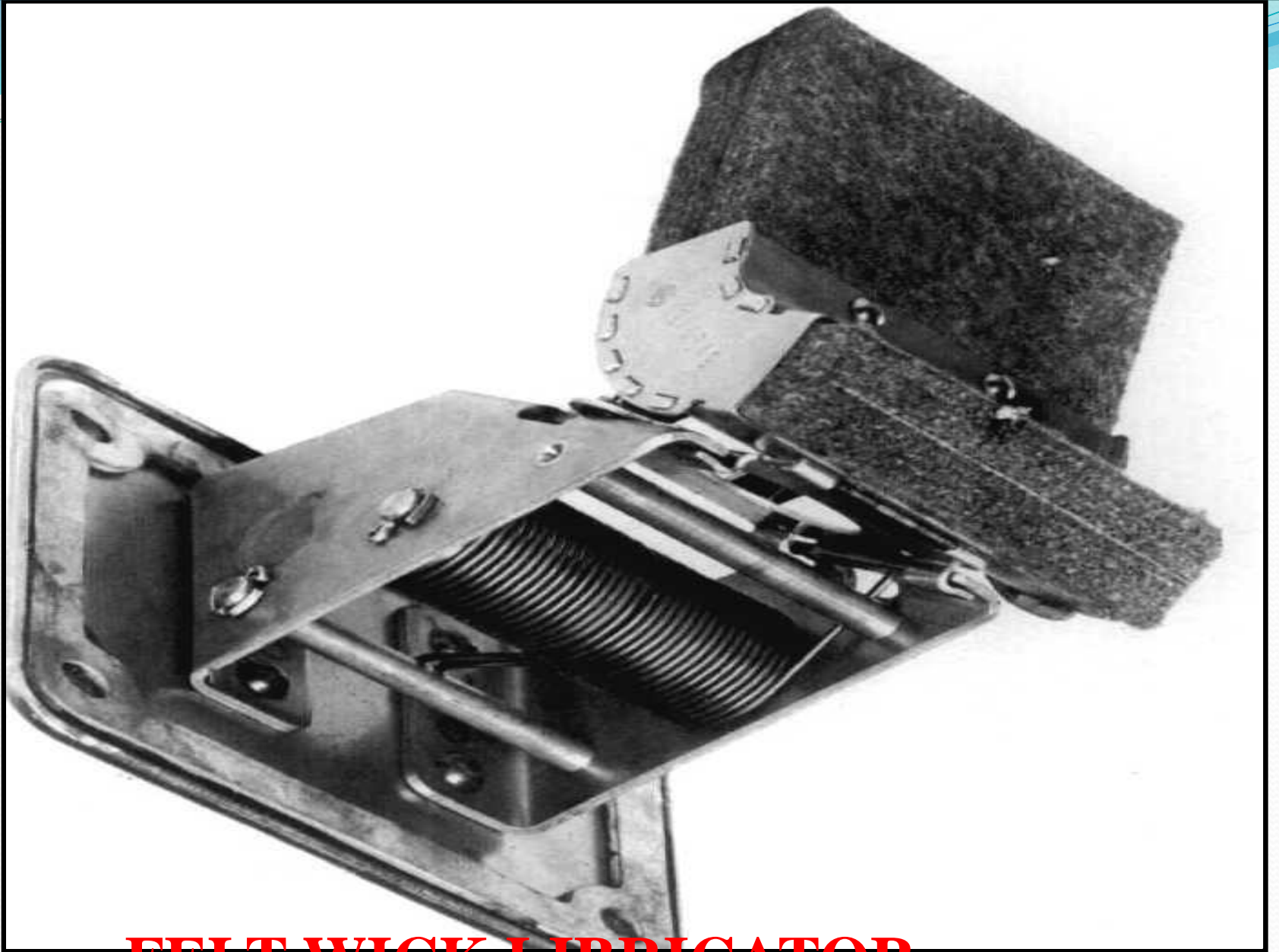

FELT WICK LIBRICATOR

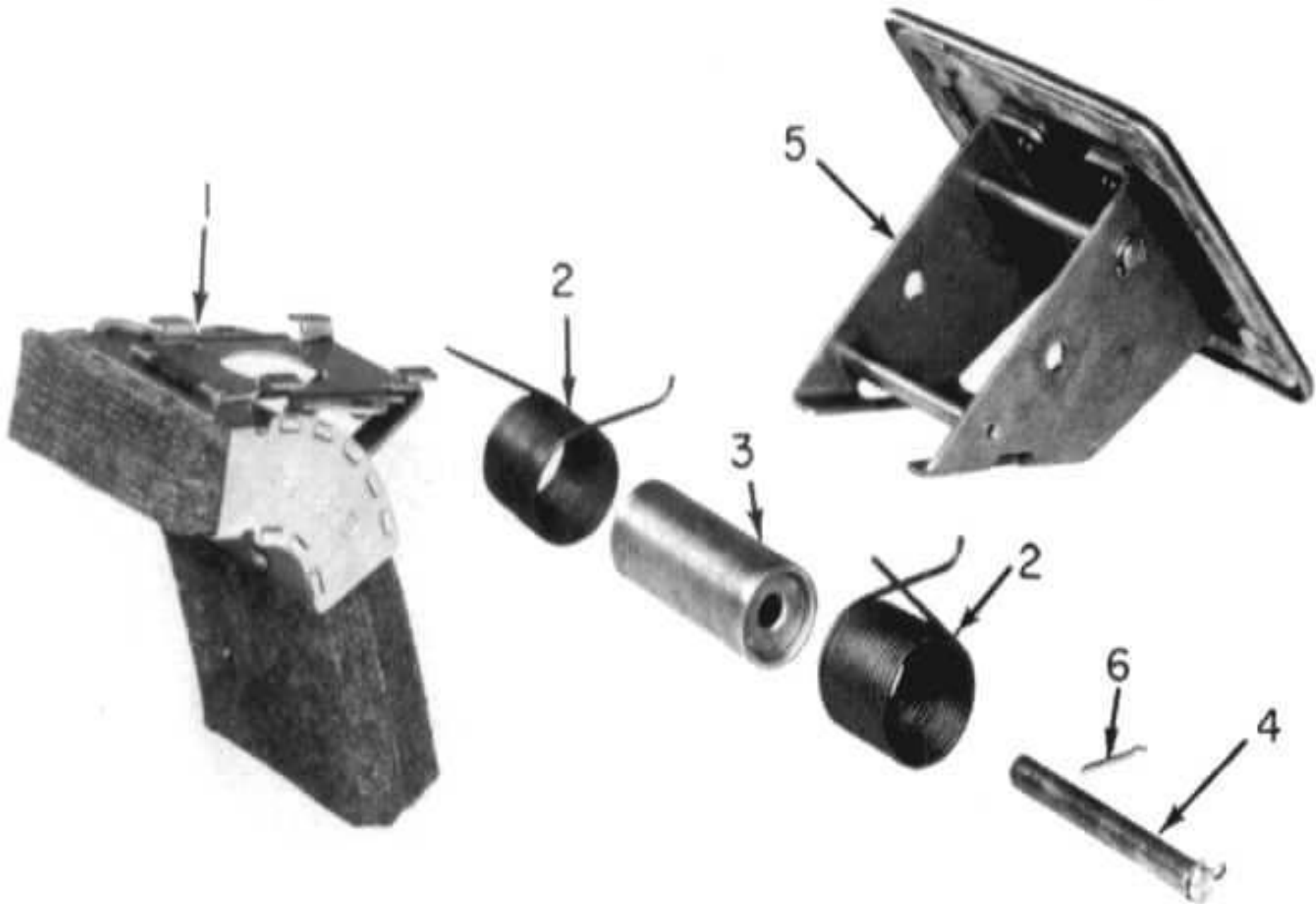

Motor Suspension Arrangement

Plain Bearing



Roller Suspension Bearing

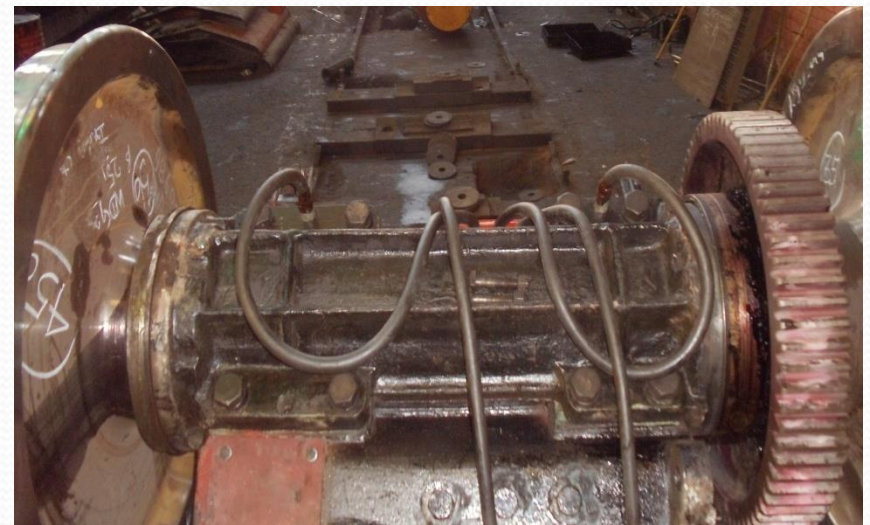
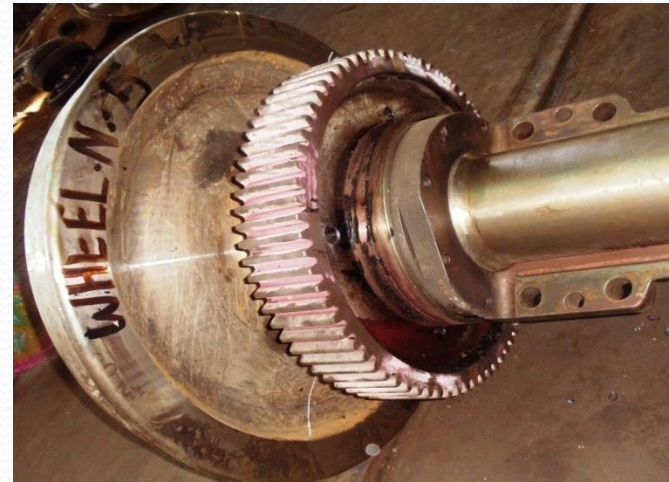

GEAR CASE OF TRACTION MOTOR AND GEAR

- The traction motor gear case encloses the traction motor pinion and axle gear, and houses the lubricant for traction motor gears. The entire gear case assembly is mounted on the traction motor magnet frame with the help of three mounting bolts. One of the bolt is located in the top half and two in the bottom half of the gear case.

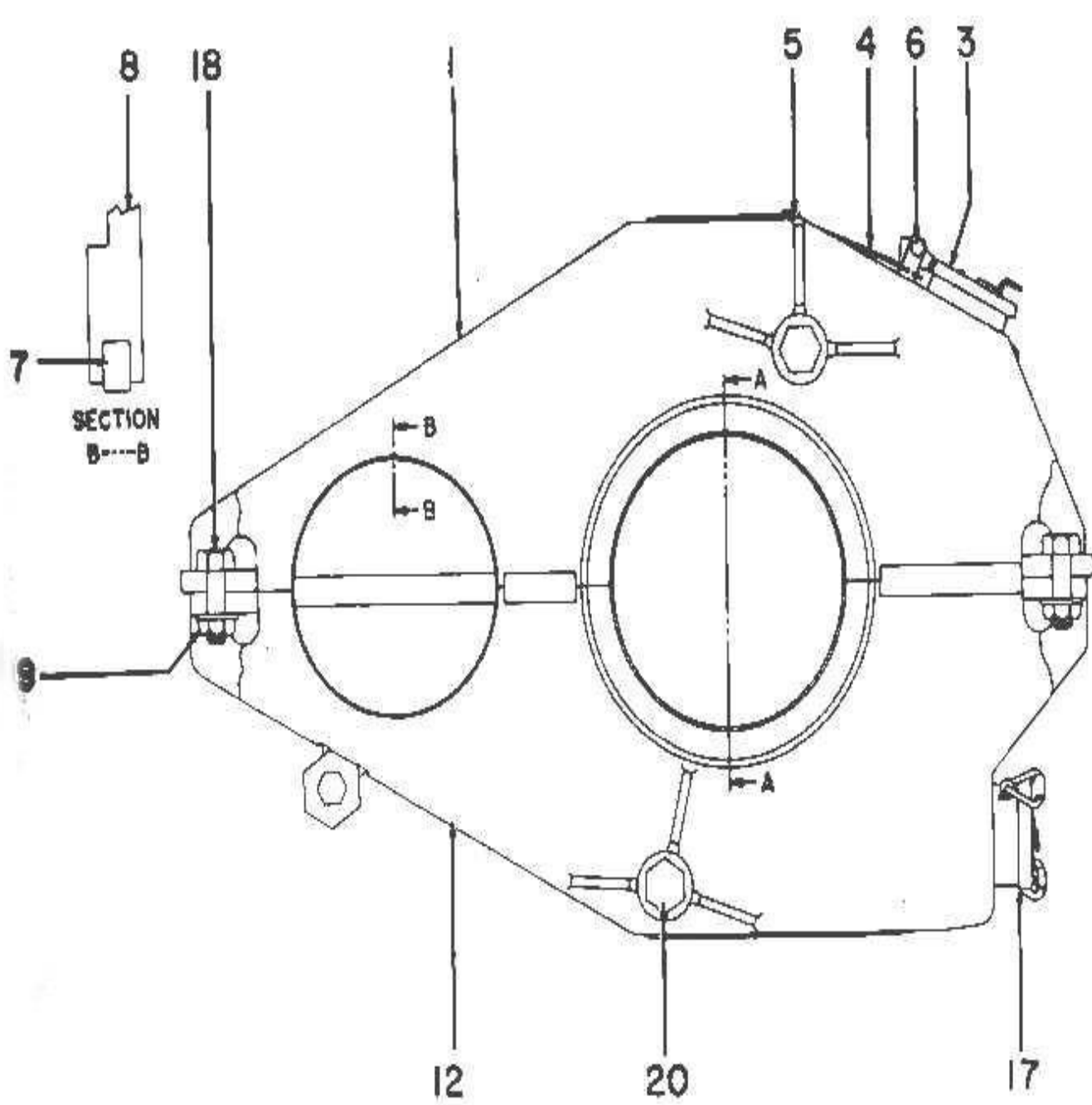

SECTION B---B
 7

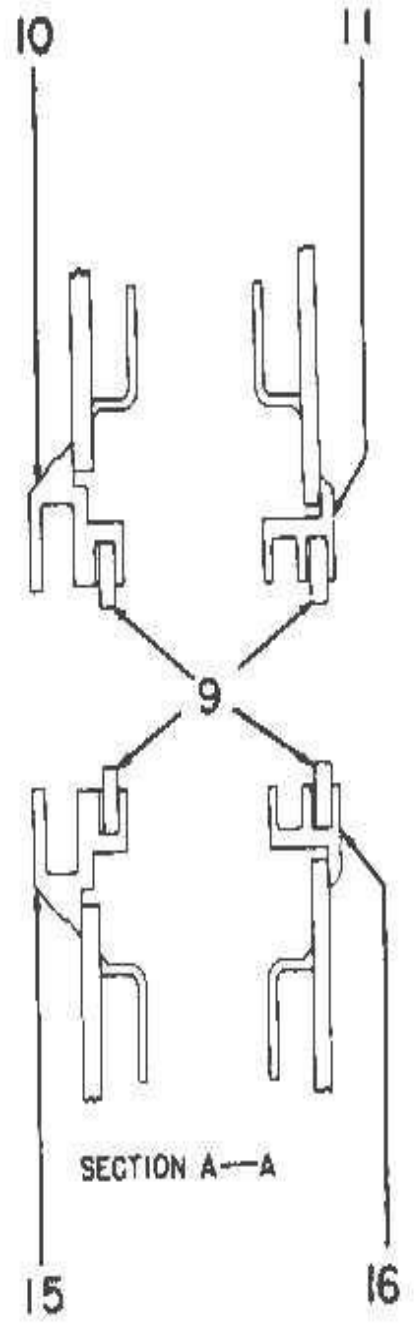

SECTION A---A

TRACTION NOSE SUSPENSION

- Examine the condition of nose suspension bolts, pin etc. Tighten and re-screw as necessary. Inspect for wear on nose suspension wear plates. Maximum clearance permitted on motor lugs is 10.00 mm. No clearance is to be allowed on the frame lugs. Renew when necessary the bonded rubber sand witch traction motor nose suspension assemblies fitted on locomotives.
- Condemn the suspension assembly if there is no pre-load at installed height. Make a visual inspection of rubber element. Discard element if loss of bond or tearing of rubber has occurred.
- Stand the element on a flat surface and check for misalignment of upper and lower plates caused by permanent set of the rubber as follows:
- OFF SET -Off set of upper and lower and plates must not exceed 5.0 mm.
- PARALLSM-Measure overall height of the element on opposite side. The difference in height must not exceed - 3.0 mm.

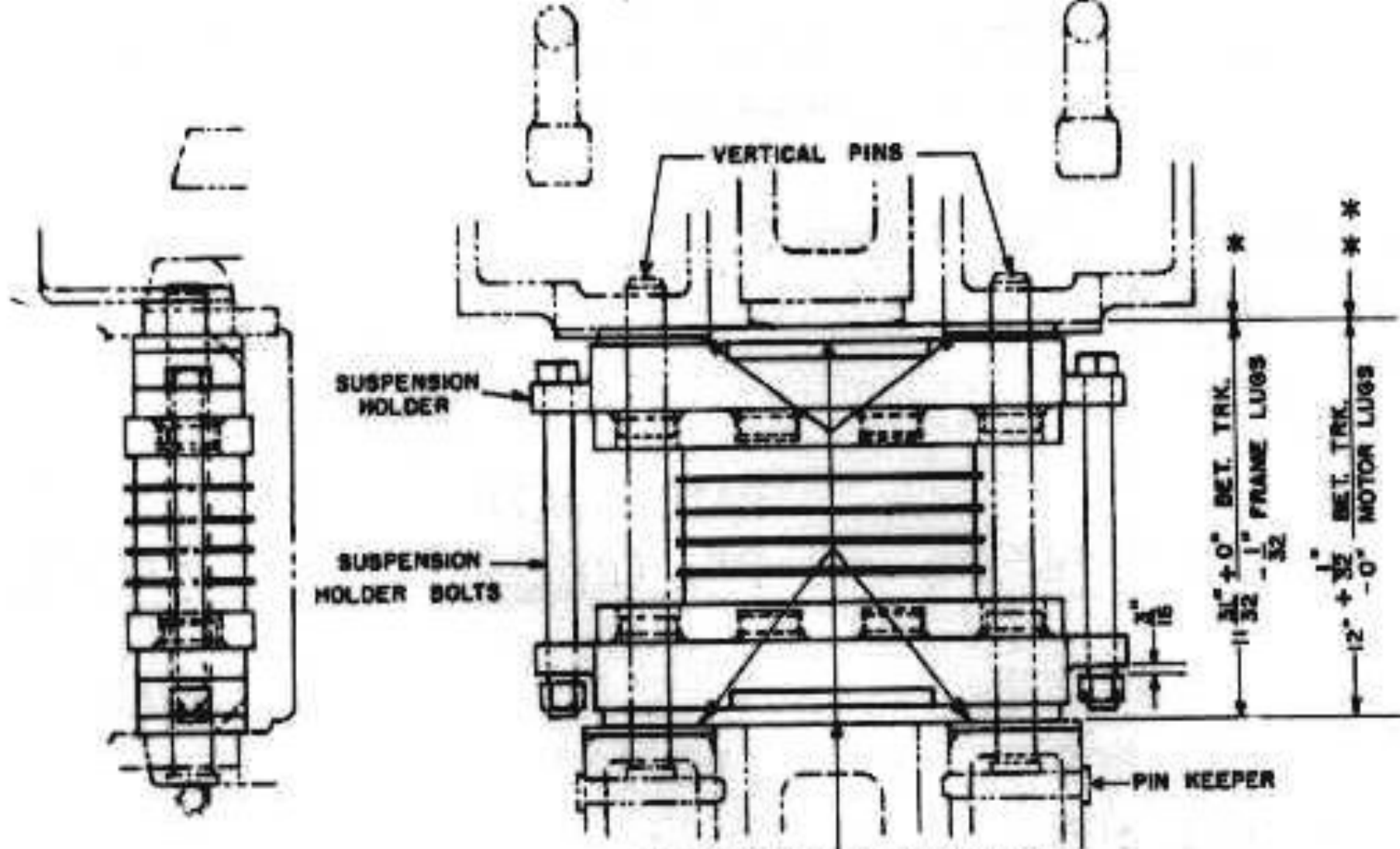

C-1095 STEEL BARS QUENCHED &
 TEMPERED TO HARDNESS BRINELL OF 375-444

- * MAY BE WORN UNTIL DISTANCE BETWEEN FRAME LUGS IS $12 \frac{1}{8}$ "
- ** MOTOR LUGS AND SUSPENSION MAY BE WORN UNTIL ACCUMULATED DISTANCE IS $12 \frac{3}{8}$ "

WHEEL SET WITH ROLLER SUSPENSION TUBE

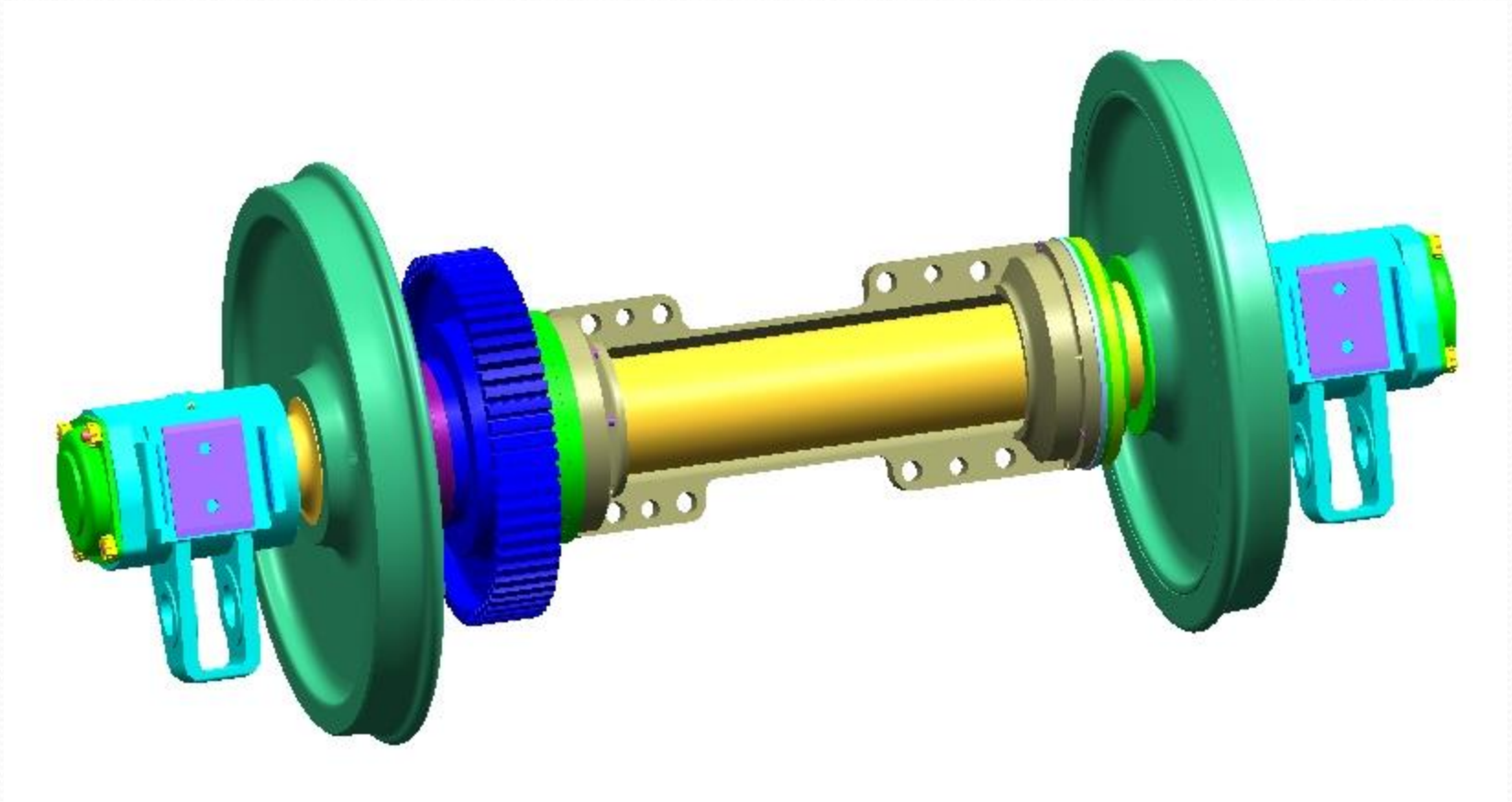

ROLLER SUSPENSION BEARING

- Significant increase in bearing life as well as longer schedule periodicity with almost 'NIL' maintenance.
- Roller bearing suspension units are fit for high speed operation.

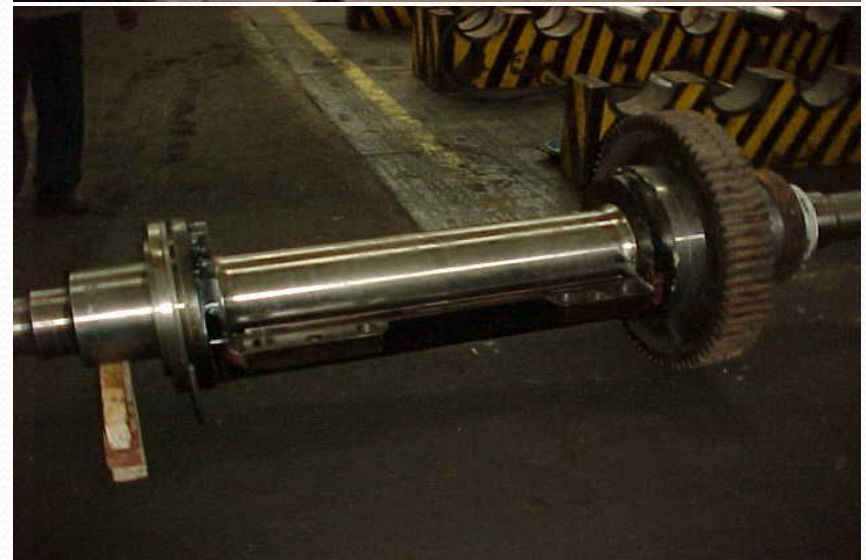

Suspension Tube Assembly

- Mainly single row Tapered Roller Bearings are used as suspension bearings.
- These bearings are used with suspension tube housing and end fittings.
- For some special applications, cylindrical roller bearings are also used as suspension bearings (ABB Locomotive).
- RANGE:
 - Single Row Cylindrical Roller Suspension Bearings (8.7 Inch Bore to 17.40 inch OD)
 - Single Row Tapered Roller Suspension Bearings (8.7 Inch Bore to 14.13 Inch OD)



SUSPENSION COIL SPRINGS

- Suspension coil springs are fitted on the bogie as follows:
- Outer coil spring - 16 nos.
- Inner coil spring without Snubber - 8 nos.
- Inner coil spring with snubber - 8 nos.

Snubber

Coil Spring

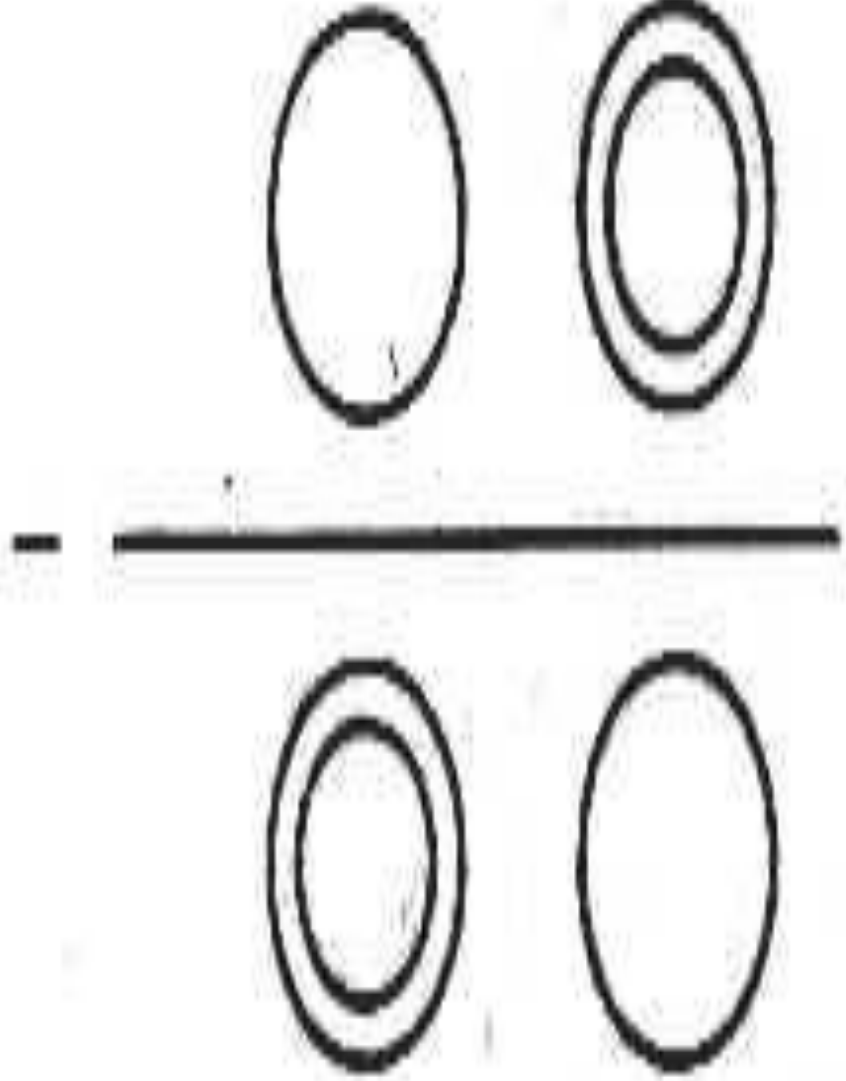
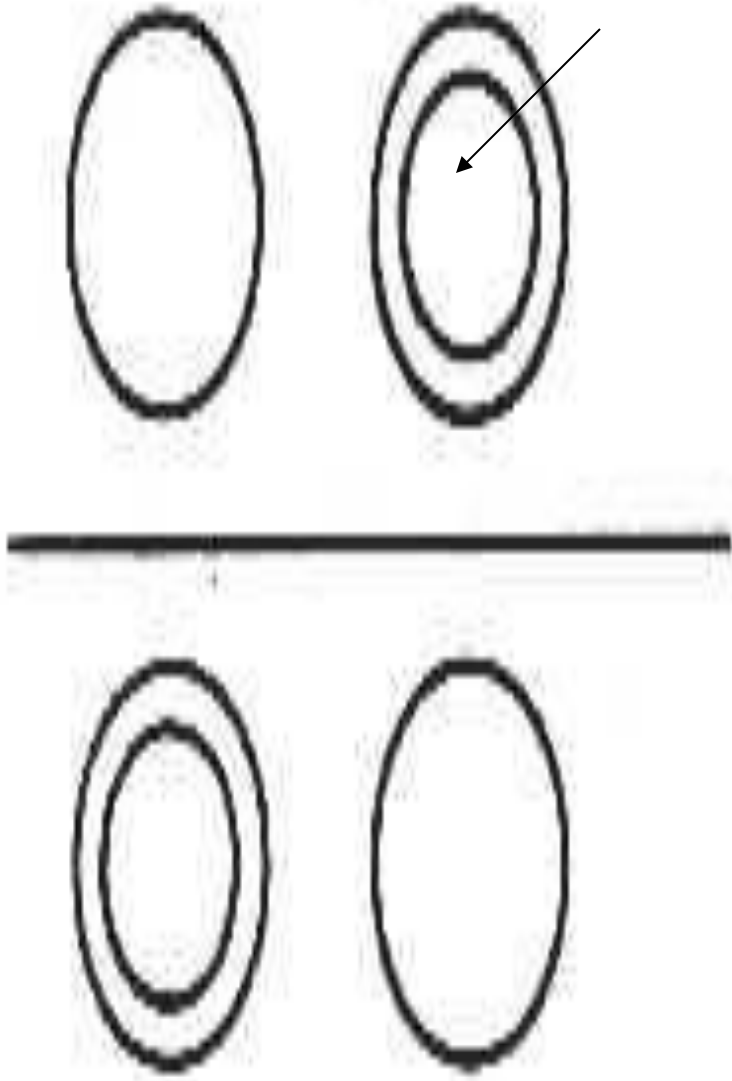
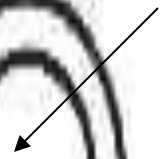

TR

• These springs have to be tested periodically before final assembly. Check and match the working height and free height of the spring. Apply protective coating of anti-corrosive paint and colour code for identification:

• **Spring free height** **Spring working height**

• **Outer** - **457 ± 7 mm** **361+4 mm**

• **-6 mm**

• **Inner** - **423 ± 7 mm** **361+3 mm**

• **-4 mm**

• **Snubber** - **428 ± 7 mm** **361±3 mm**

•

EQUALISER BEAM

- There are three types of equaliser beams are fitted on bogies:
- Wide Horn
- Narrow horn
- Modified

- Equaliser beams of trimount CO-CO bogies are provided with locating roller pins on the end axle boxes. They rest freely on the centre of axle box. It is important to ensure that the pin does not sit on the seat. The locating pin has a clearance of 05.00 mm in the corresponding slot of the axle box.
- In the normal working condition the equaliser pin should be free to rotate.

SPRING SNUBBER

- The friction being generated by friction shoes rubbing up and down inside a friction sleeve. The snubber of simple construction, comprising a low carbon, case hardened sleeve to which is welded a forged steel cap, a bottom ring and three alloy steel friction shoes held in assembly with the sleeve by six pre-compressed friction shoe springs which are equally spaced vertically and radially and an outer coil spring.

Disassemble operation of Snubber

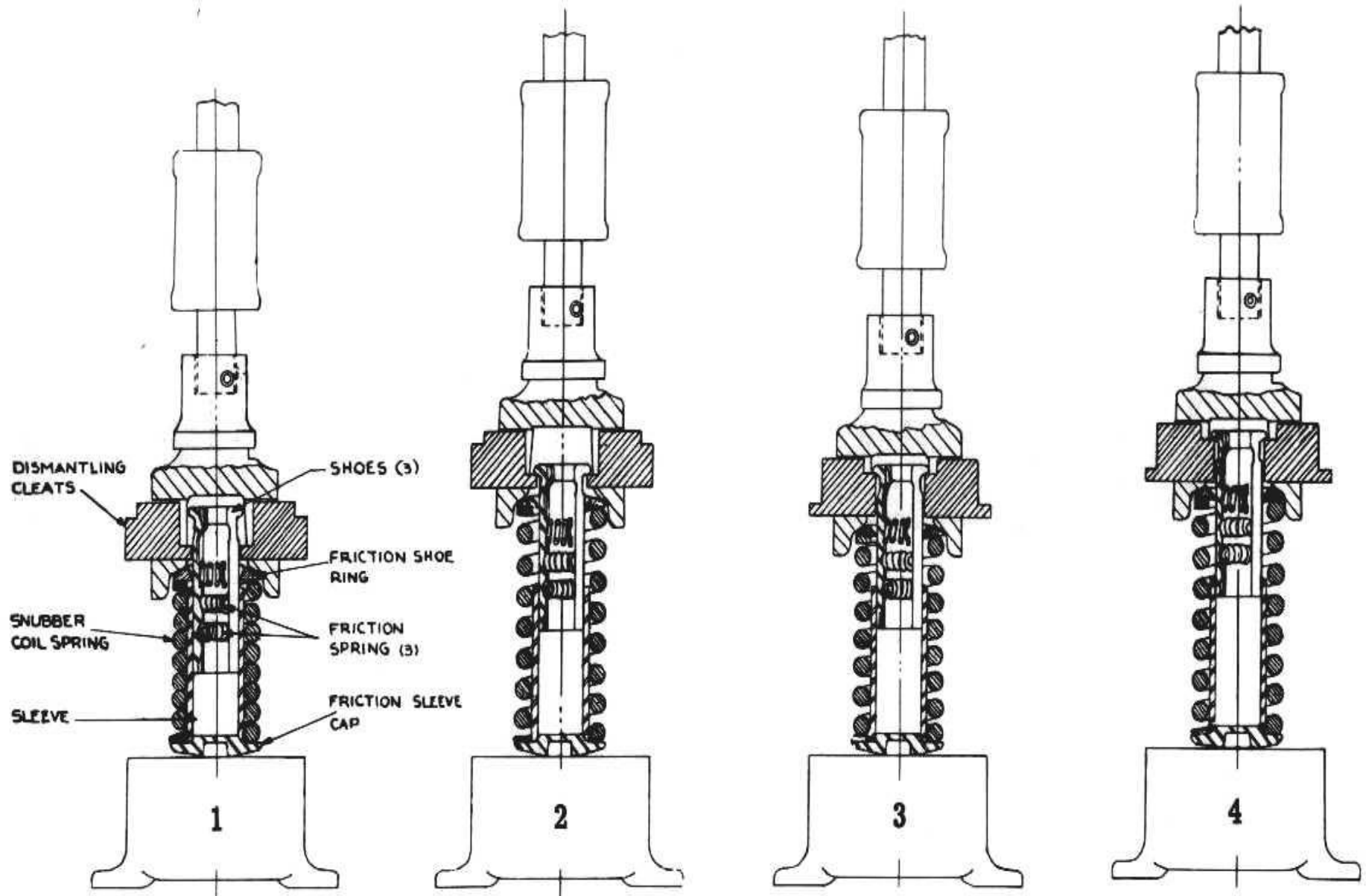

REMOVAL OF BOGIES FROM LOCOMOTIVE

- When bogies are required to be removed for the purpose of scheduled overhaul or during out of course attention to any particular equipment the locomotive can be lifted with crane, hoists and Jacks.

LIFTING OF LOCOMOTIVE

- Place the locomotive on repair line
- Disconnect the following before any attempt is made for lifting the locomotive for running out the bogies.
- Safety lugs pins (one on each side of the bogie at swivel bowl bolster) and strap at inward transom.
- Air brake pipe connections
- Hand brake chains and brake pull rods
- Sand pipe connections
- Air duct connections (Air duct can be unbolted at motor end)
- Traction motor leads
- Speedometer connections

After ensuring that all physical connections between the superstructure and the bogie have been disconnected, the bogie can be removed by the following procedures.

Place the high lift jacks and lift the super structure

Run out the bogies along with the track.

● PRECAUTIONS

- When lifting or jacking of locomotive, to remove one or both the bogies, all four corners should be raised equally to prevent strain on under frame.
- The super structure should not be lifted excessively more at one end than at the other end until the body swivel castings have become disengaged from the bogie swivel bowl.

WDM₂ एवं WDG₃ बोगी में अंतर

क्र	विवरण	WDM ₂	WDG ₃
01	नाम	ट्राईमाउण्ट बोगी	हाई एडहैशन बोगी
02	फ्रेम	कॉस्टिंग फ्रेम	फेब्रिकेटेड फ्रेम
03	लोड कैपेसिटी	कम	अधिक
04	वेट डिस्ट्रीब्यूशन	सेन्टर पीवोट – 60 साइड पीवोट – 40	इनर साइड बियरर – 40% आउटर साइड बियरर – 60%
05	गियर अरेंजमेंट	L ₁ , L ₂ , R ₃ , L ₄ , R ₅ , R ₆	L _{1,2,3} , R _{4,5,6} ,
06	सस्पेंशन	सिंगल स्टेज सस्पेंशन (क्वाइल स्प्रिंग)	डबल स्टेज सस्पेंशन (प्राइमरी – स्प्रिंग सेकेण्डरी- साइड बियरर)
07	हाइड्रोलिक शाक अप	नहीं हैं	4- वर्टिकल 2- होरिजेंटल
08	स्प्रिंग हाइट बफर	1030- 1105 एमएम	1030 –1105 एमएम
09	स्नबर	लगे हैं 1,3,5,7 एवं 2,4,6,8	नहीं लगे हैं
10	स्प्रिंग	आउटर –8, 8 इन्नर –4, 4	आउटर –8, 8 इन्नर –8, 8
11	साइड बफर पैड	नहीं हैं	प्रत्येक बोगी में दो दो लगे हैं
12	एक्सल बाक्स	नैरो हॉर्न / वाईड हार्न में अलग – अलग लगे हैं	केवल वाईड हार्न , हाई स्पीड एक्सल बाक्स बाटम पलैंज के साथ लगे हैं
13	गियर रेशियो	18:65	18:74
14	इक्वलाइजिंग बीम	दो का सैट 5 फुट 7 इंच एवं 6 फुट 11इंच	केवल एक बीम / सभी बीमो की लंबाई बराबर हैं
15	सैण्ड बाक्स	लोको के लॉग हुड एवं शाट हुड दोनों में लगे हैं।	फ्रेम के ऊपर प्रत्येक में चार चार सैण्ड बाक्स लगे हैं

HIGH ADHESION BOGIES OF ALCO LOCOMOTIVES

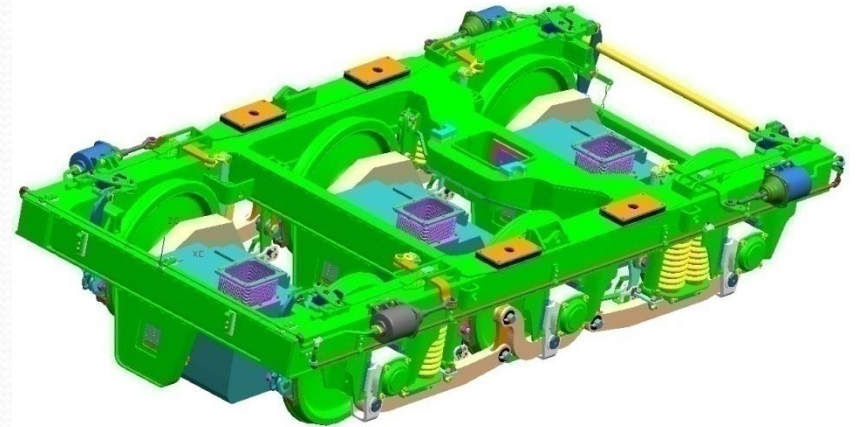

BOGIE FRAME CONSTRUCTION

- Co-Co type
 - Manufactured from steel plate to IS.2062 grade 'C'
 - Fabricated box type construction
 - Three transoms to carry nose suspension,
- Traction motor nose positions
 - Oriented to the same side of each axle

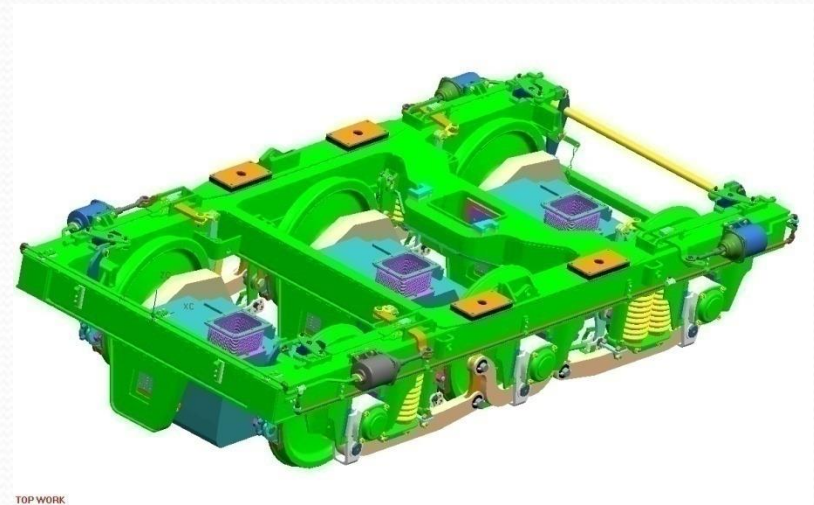

BOGIE DESCRIPTION

- Bolster-less bogie
- Two-stage suspension,
 - Helical coil springs and shockers in primary stage
 - Rubber compression springs in secondary stage of suspension)
- Floating type center pivot arrangement
 - Does not take any vertical load
 - Used only for transfer of
 - traction and
 - braking forces

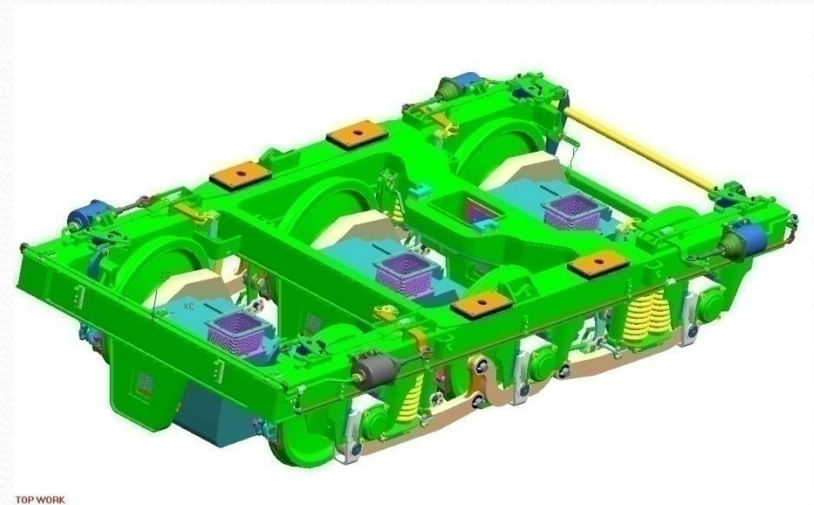

EQUALISATION OF WEIGHT

- Bogie frame
 - Supported on axles through helical coil spring mounted on equalizing beams.(Compensating Beam)
- Equalizing mechanism
 - Enables achievement of equal axle loads
 - On uneven track.
 - Equalizers hung directly on end axle boxes
 - Supported on middle axle box
 - Link and
 - Compensating beam arrangement.

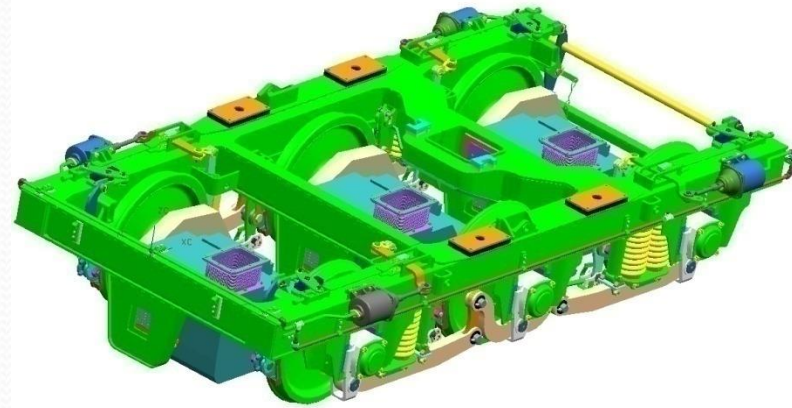

TOP WORK

TRANSFER OF WEIGHT

- Equally @25% to the bogie frame through four rubber side-bearers directly mounted on bogie side bears.
- Rubber Side Bearers
 - Stiff to provide lateral guidance at the secondary stage
 - Provide the yaw stiffness for stability.
 - Spaced for stability of locomotive
 - Damping of track oscillations

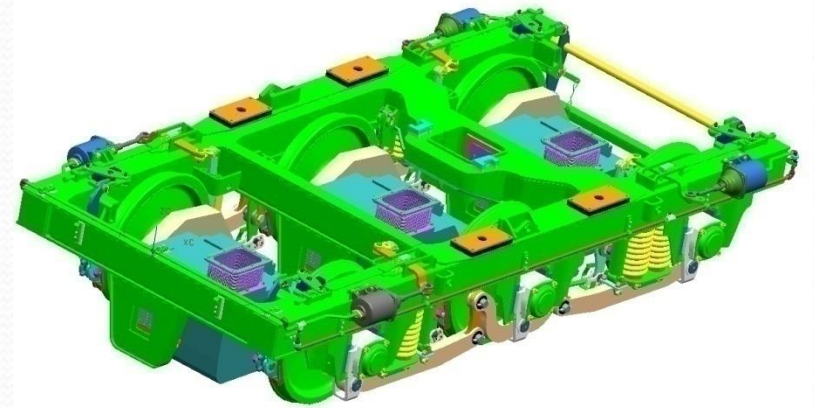

SAFETY LINKS & SAND BOXES

- Safety links
 - Prevent separation of the bogie from the locomotive car body in case of derailment.
 - Provide means of lifting the bogie along-with the locomotive body.
- Sand Boxes
 - In WDG_{3A}
 - four numbers Bogie mounted
 - In WDM_{3D}
 - All four under frame mounted.

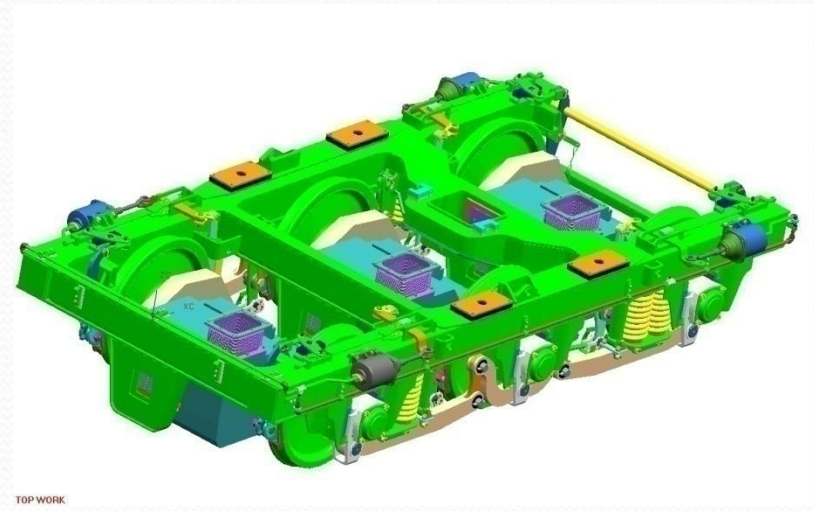

EQUALISER LESS (HAHS-1) BOGIES

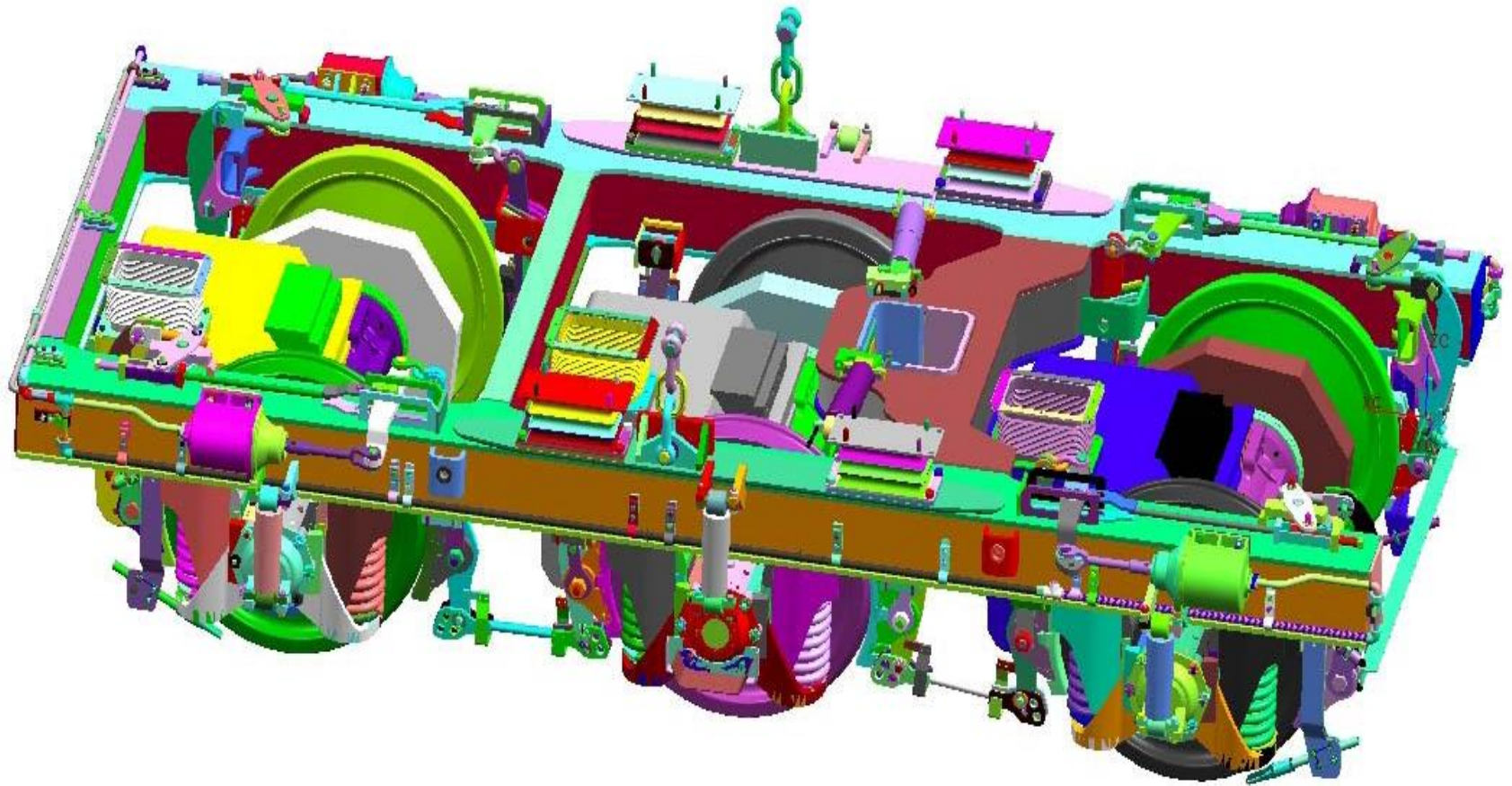



SIMPLEX

HAHS-1 BOGIES (introduction)

- Modification over high adhesion bogies & designed for high horse power ALCO locomotives to achieve higher tractive effort at start.
- 3-axle type bolster less bogie with two stage suspension, floating pivot and uni-directional arrangement of axle hung, nose suspended traction motors.
- The locomotive body weight is supported on bogie frame through four rubber side-bearers directly mounted on bogie side beams.
- Side-bearers adjacent to centre pivot take 60% weight while the other two take 40%.
- The bogie frame in turn is supported on axles through helical coil springs mounted on wing type axle boxes.

HAHS-1 vs High Adhesion Bogie.

- HAHS-I
 - High adhesion with high tractive effort.
 - Primary suspension springs arranged on winged type axle boxes.
 - Vertical shock absorbers fitted with axle box.
 - Load distribution not equal
 - Two bearers adjacent to centre pivot @ 30%
 - Two other bearers @ 20%
- High Adhesion
 - Only high adhesion.
 - Primary suspension springs arranged on beams.
 - Vertical shock absorbers fitted on beams.
 - Equal Load distribution by all four side bearers @ 25%.

ANY QUESTIONS

???

THANK YOU