

# Bogies & Suspension of Freight stock



# INTRODUCTION:

Since 4-wheeler stock is gradually being phased out, Indian Railways have a close and intensive observation to introduce latest and most effective bogie through regular modifications. As such, previously, following four types of bogies were used in wagon stock in different types of wagon.

<b>SL NO</b>	<b>TYPES OF BOGIES</b>	<b>WHERE USED</b>
1.	Diamond frame bogie	Used in BOB wagon
2.	Cast Steel bogie	Used in BWT (Well) wagon
3.	UIC fabricated bogie	Used in Vacuum brake bogie stock
4.	CASNUB bogie	Used in Air brake bogie stock

# ISOMETRIC VIEW OF UIC BOGIE:

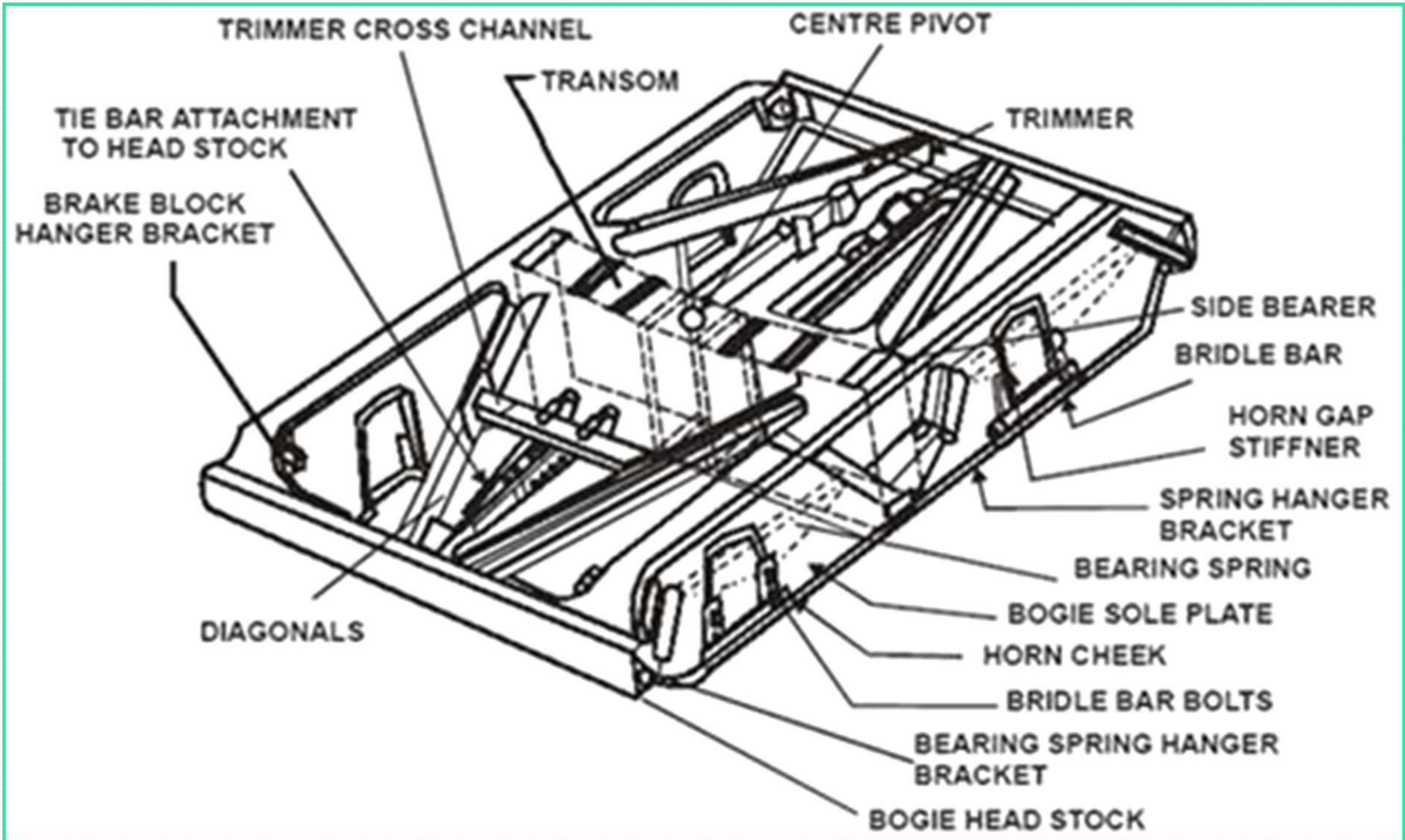



- ❖ At present, there is no existence of Diamond frame, Cast steel and UIC bogies in Indian Railways.
- ❖ Only **CASNUB bogies** are of different versions in use.

## **CASNUB BOGIE:**

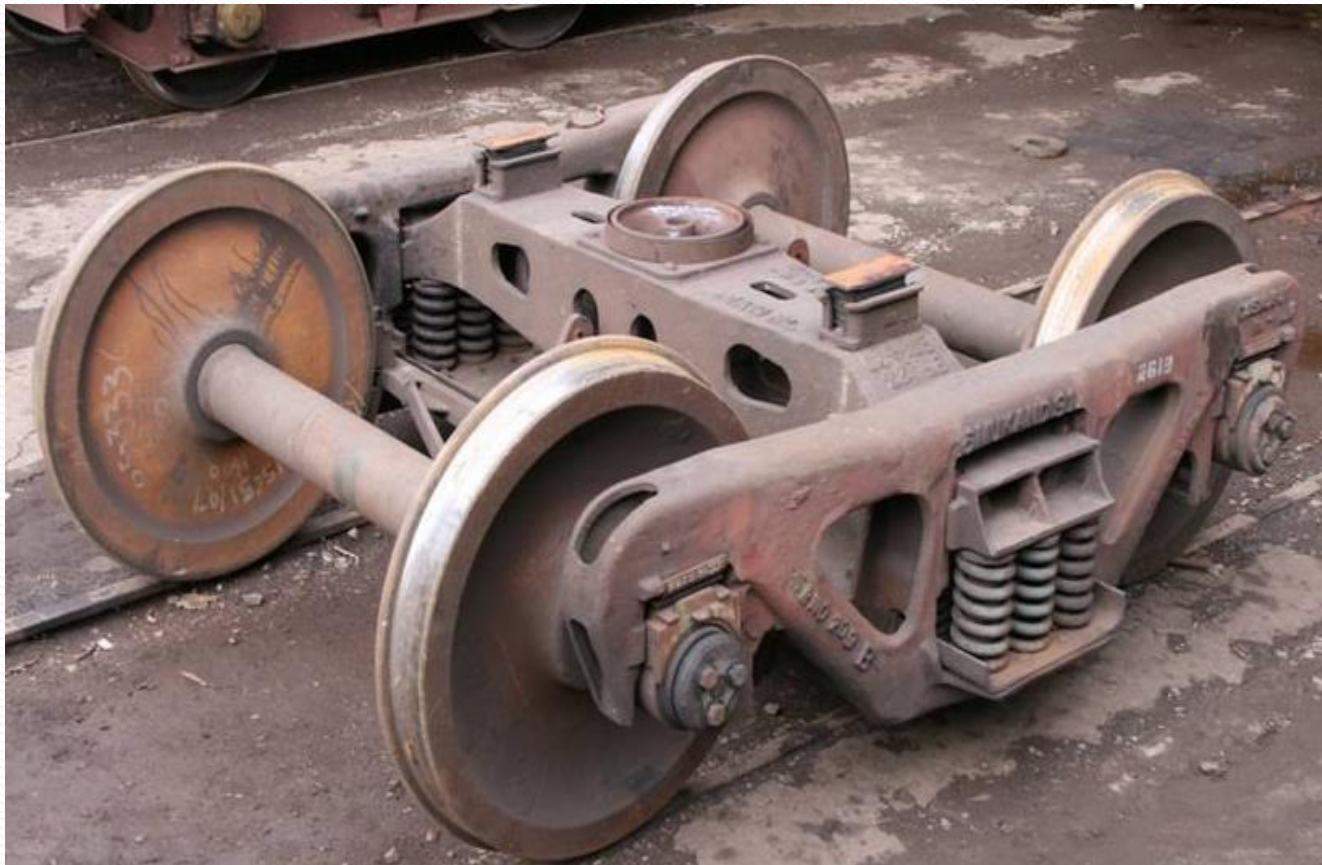

# History of CASNUB Bogie:

- Casnub Bogie was introduced to overcome the drawbacks experienced in running of UIC bogie
- First tested in 1972 under BOI wagon and was found safe to run at test speed up to 110 kmph
- In 1981 trials were again undertaken on CASNUB bogie under BOXN wagon to maintain the main line standard and its behaviour was well within safety limits up to 90 kmph speed and was designated as CASNUB 22W
- These were modified as CASNUB 22W(M) mainly to take care of high wheel wear reported on earlier versions
- Subsequently CANUUB 22 NL (Narrow jaw) and CASNUB 22 NLB (Narrow jaw with fish belly bolster) version were introduced
- CASNUB 22HS and CASNUB 22HS (Mod-I) bogies have been developed for high speed operation with maximum permitted speed up to 100 kmph

# General construction of CASNUB Bogie:

- The term “CASNUB” has its origin from two words ‘Cast’ and ‘Snubbing’
- CASNUB BOGIE means Cast Steel Bogie equipped with snubber spring
- The cast steel Casnub bogie comprises of two cast steel side frames and a floating bolster
- The bolster is supported on the side frames through two groups of springs (Bolster spring and Snubber springs), which also incorporate a load proportional friction damping
- Provided with secondary suspension only and no primary suspension is available
- The side frames are connected by a fabricated mild steel spring plank to maintain the squareness of the bogie



# CASNUB bogie – Front view

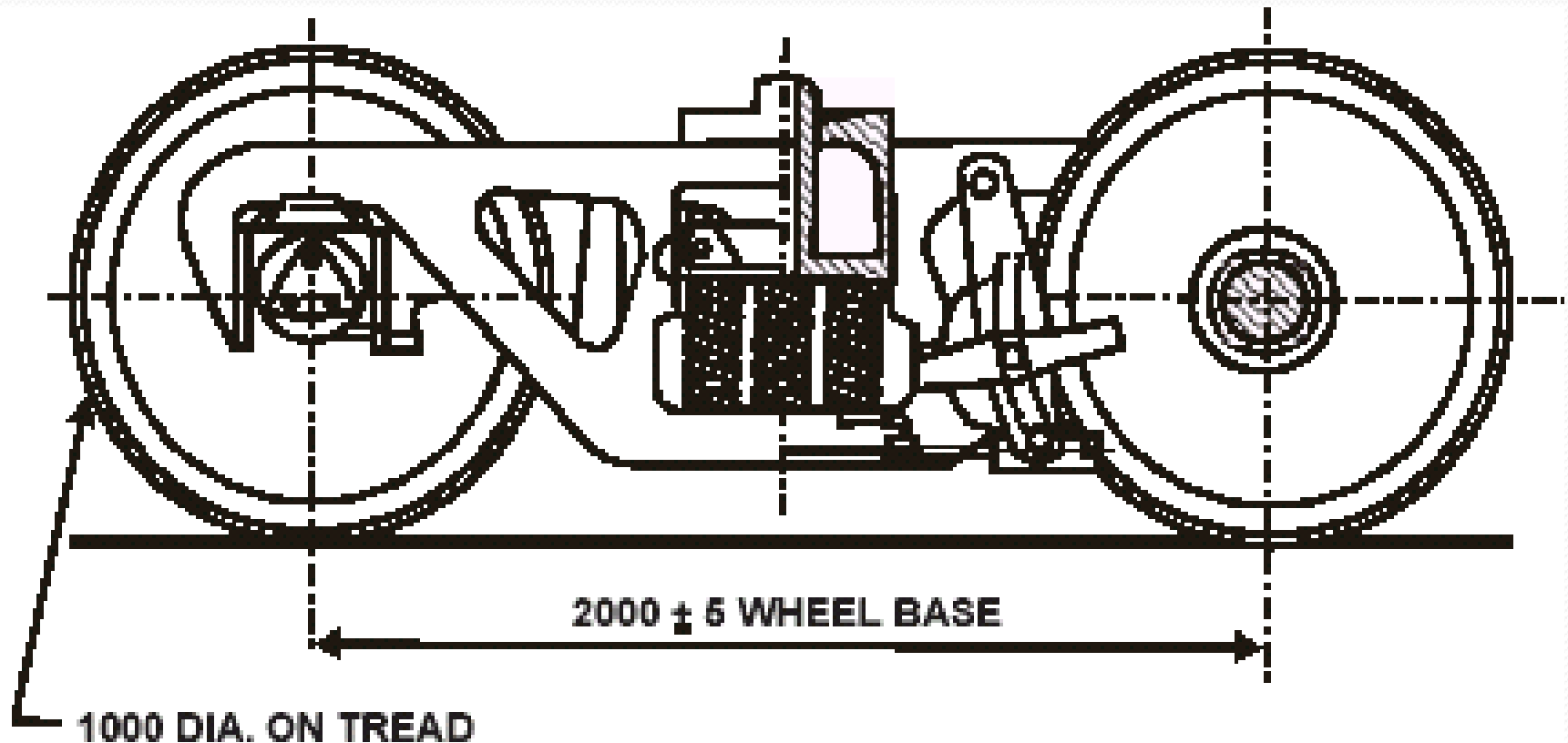

# CASNUB bogie – top view

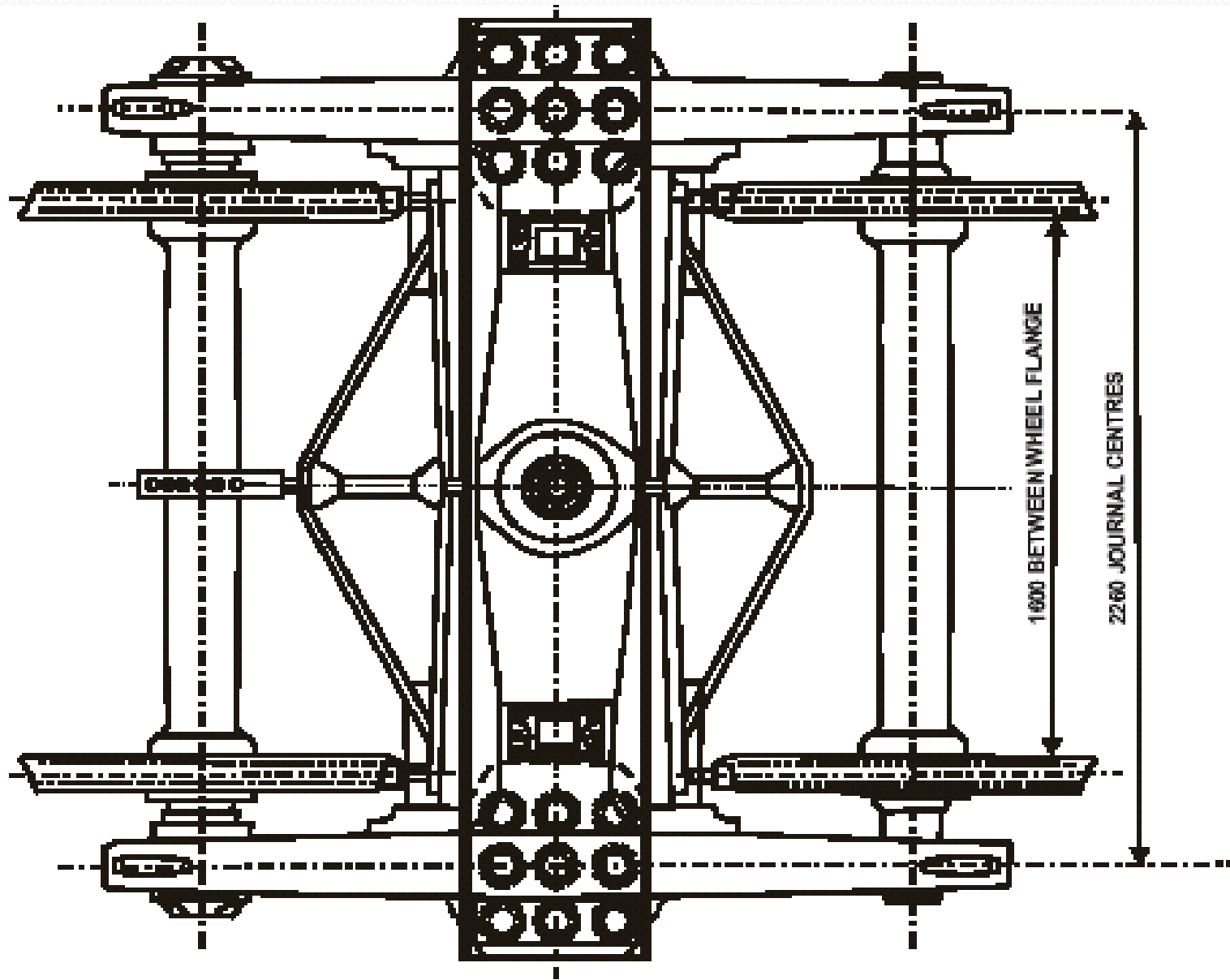



LOCATIONS TO BE RECLAIMED

- SIDE FRAME COLUMN SIDES.
- ANTI-ROTATION LUGS.
- SIDE FRAME FRICTION LINERS.
- PEDESTAL CROWN ROOF.
- PEDESTAL CROWN SIDES & PEDESTAL SIDES.
- PEDESTAL JAW.

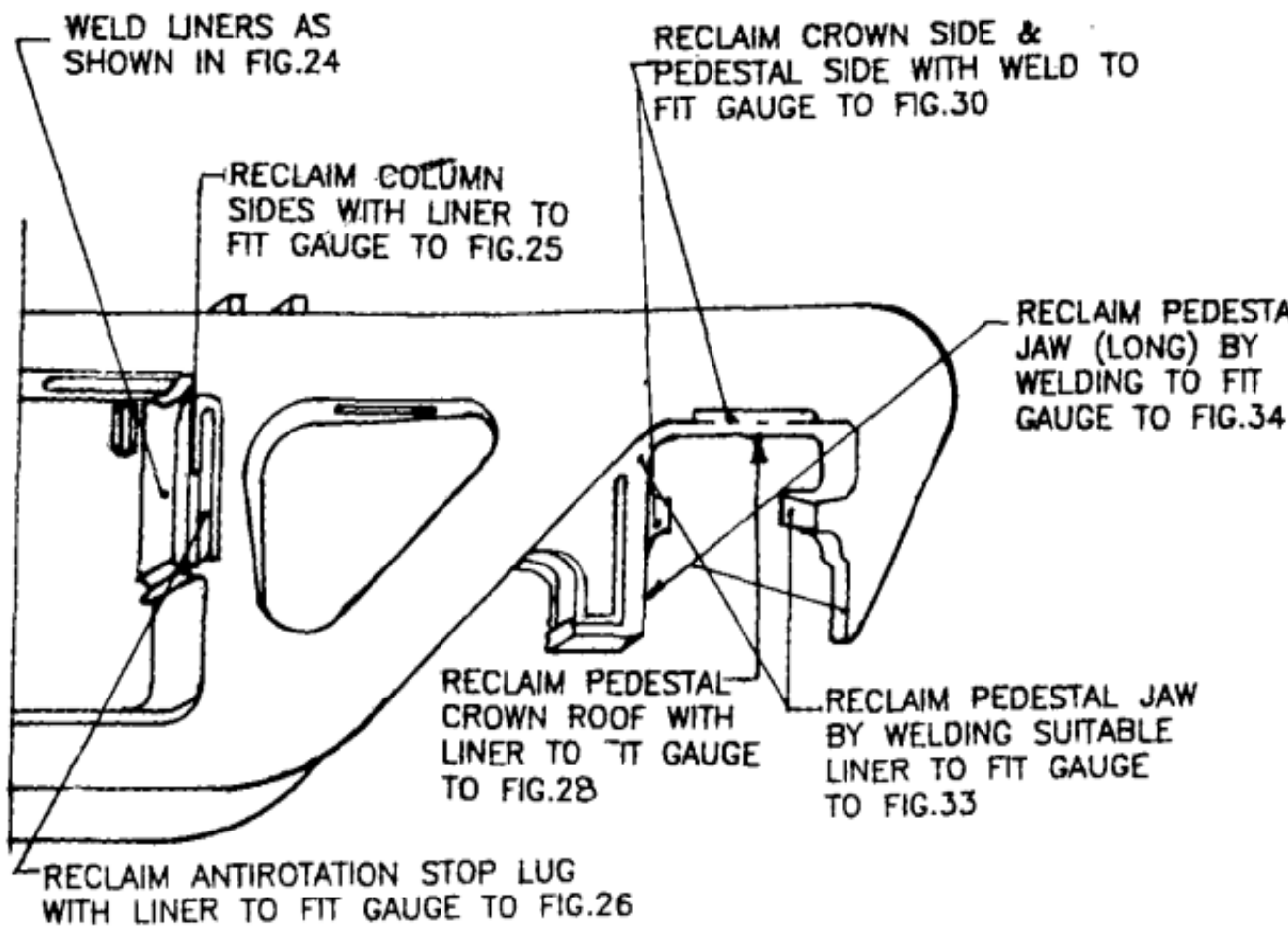

# VERSIONS OF CASNUB BOGIE:

- CASNUB 22W
- CASNUB 22W (R)
- CASNUB 22W (M)
- CASNUB 22 NL
- CASNUB 22 NLB
- CASNUB 22 NLM
- CASNUB 22 HS & IRF 108HS
- CASNUB 22 HS MOD I/MOD II
- CASNUB 22 NLC
- LCCF 20 (C)–Low Container Flat Bogie
- LWLH – Light Weight LowHeight

## ABBREVIATION USED FOR BOGIES

W= Wide Jaw

R = Retrofitted

M= Modified

N = Narrow Jaw

L = Light weight

HS= High Speed

B =Belly shaped bolster

## (i) CASNUB 22W:

- Introduced in 1972
- IRS type centre pivot riveted and welded or casted
- Provision of floating bolster
- Provided with Roller type side bearer
- Provision of adapter retainer bolt in outer jaw
- Fitted with CTRB
- Provision of wide jaw adapter
- E M pad not provided
- Sliding pocket type brake beam

## (ii) CASNUB 22W (R):

- Introduced in 1990
- Weight 5.35 T
- Provision of floating bolster
- IRS pivot riveted and welded or casted
- Constant contact metal bonded rubber pad in side bearer
- Fitted with CTRB
- Provision of adapter retainer bolt in outer jaw
- Provision of modified wide jaw adapter with 25.5 mm thickness
- Provided with Elastomeric pad
- Fitted with sliding pocket type brake beam



### **(iii) CASNUB 22 W (M):**

- IRS spherical centre pivot riveted and welded or casted
- Provided with floating bolster
- Provided with Constant contact side bearer
- Provided with unit type suspended cast steel brake beam
- Provided with wide jaw Adapter
- Provided with elastomeric pad
- Fitted with CTRB

## (iv) CASNUB 22NL:

- Introduced in 1989-90
- Weight 5.5 T
- Provided with UIC type spherical centre pivot
- Provided with floating bolster
- Provided with constant contact metal bonded rubber pad in side bearer
- Provided with Narrow jaw adapter
- Adapter retainer bolt not provided
- Provided with Elastomeric Pad
- Fitted with Cartridge Taper Roller bearing
- Fitted with sliding pocket type brake beam

## (v) CASNUB 22 NLB:

- Introduced in 1990-91
- Weight 5.4 T
- Provided with Spherical type centre pivot
- Fish belly shaped bolster has been used
- Constant contact type mental bonded rubber pads in side bearer
- Provided with narrow jaw adapter
- Adapter retainer bolt not provided
- Provided with E M pad provided
- Fitted with CTRB
- Weight has been reduced
- Fitted with sliding pocket type bake beam

## (v) CASNUB 22 NLM:

- Similar to NLB version in relation to dimensions of the components
- Only difference is change in material of the side frame and bolster
- The equivalent carbon % age of side frame and bolster in NL/NLB is 0.85%
- Resulting reduction of weight of the bogie compared to NL version
- Weight of the NLM version bogie is 5.125 ton where as the weight of NL version is 5.5 ton



## **(vi) CASNUB 22HS & IRF 108 HS:**

- Introduced in 1993
- Weight 5.4 T
- Provision of UIC type spherical centre pivot
- Provided with spring loaded side bearer
- Provided with Two stage suspension suspension (softer in tare and stiffer in gross)
- Provided with narrow Jaw Adapter
- Adapter retainer bolt not provided
- Provided with Elastomeric Pad
- Fitted with Cartridge Taper Roller bearing
- Higher lateral clearance between frames and bolster
- Fitted with sliding pocket type bake beam

## **(vii) CASNUB 22 HS MOD1/MOD II:**

- Provision of Flat centre pivot
- Provision of PU pad type constant contact side bearer
- Provided with narrow jaw adapter
- Provided with Elastomeric Pad
- Fitted with Cartridge Tapered Roller Bearing
- Higher lateral clearance between frames and bolster
- Fitted with sliding type brake beam

## **(viii) CASNUB 22 NLC (25 T AXLE LOAD):**

- Same as CASNUB 22 NLB, except modification in suspension
- PU pads are provided in side bearer

## (ix) LCCF-20(C):

- These bogies shall be suitable for fitment of 840 mm diameter wheel sets
- Cartridge bearings with wide jaw adapter
- Elastomeric pads
- Spring loaded side bearers
- These bogies are to be fitted under low platform BG Container

**The Casnub bogies of type 22W  
& 22W(Retrofitted) have been  
phased out**

## Various bogie versions and their use in wagons:

<b>Bogie</b>	<b>Axle Load</b>	<b>Type of Wagon</b>
CASNUB -22 NLB	20.32t & 22.9t	BOXN, BOXNM1, BCN, BCNM1, BCNA, BCNAM1, BOBR, BOBRM1, BOBRN, BOBRNM1, BRN, BRNA, BTPN, BTAP, BTPGLN, BOBYN, BOBSN, BOY, BCCW, BRSTN, BWTB, BOMN etc and M1 variant.
CASNUB -22HS	20.32t & 22.82t	BOXNHS, BOXNHSM1, BOXNLWM1, BCNHS, BCNHL, BCCW, BCNAHS BOBRNHS, BRNHS, BRN22.9, BRHNEHS, BOSTM1, BOBYN22.9, BOST, BOXNHL BOXNLW, BFNS etc and M1 variant of above.
CASNUB - 22HS (Mod-I)	20.32t & 22.32t	<b>BOSTHS, BOSTHSM1, BCBFG</b>
CASNUB - 22HS(Mod-II)	22.32 t	BOSTHS M2
CASNUB -22 NLC	25.0 t	BOBRNEL, BOYEL, BOXNEL, BOBSNM1
IRF-108HS	22.82 t	BOXNHAM, BOXNHA, BOXNR, BCCN
LCCF 20(C)	20.32 t &	BLLA/B, BLCA/B, BLCAM/BLCBM, BCACM, BCACBM



# ALL BOGIES EXCEPT CASNUB 22W(M)

The brake heads are fitted with unit type fabricated brake beams that slide in the guide cavity provided in the side frame

integral part of the brake  
Bearings

Cavities are provided with silico manganese steel liners

It ensures application of two brakes equally on

wheels of axle and ensures application of braking force without eccentricity

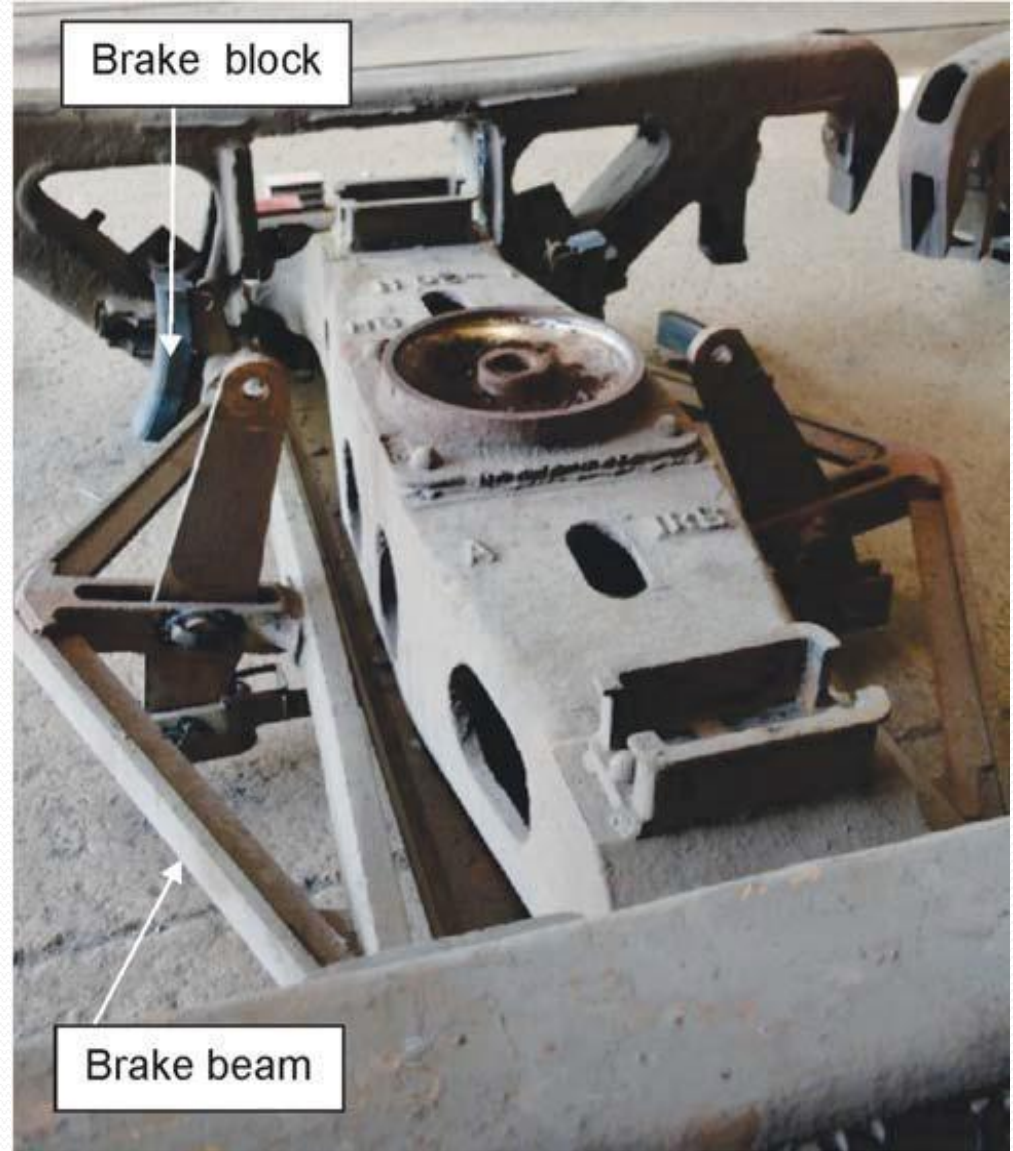



**GUIDE  
CAVITY**

# Salient features of CASNUB bogie:

Sr. No	Features	Description
1.	Gauge	1676 mm
2.	Axle load	<ul style="list-style-type: none"> <li>• Modified CASNUB 22HS (Mod-I) - 22.32t</li> <li>• CASNUB 22HS (Mod-II) - 22.32t</li> <li>• CASNUB 22NLC - 25t</li> <li>• IRF 108HS - 23.5 t</li> <li>• All other bogies* - 20.32 t</li> </ul> <p>*However these can be upgraded to CC+8t+2t with certain changes in the suspension.</p>
3.	Wheel Diameter	<ul style="list-style-type: none"> <li>• 1000 mm - New</li> <li>• 906 mm - Condemn[for all except CASNUB 22NLC &amp; LCCF 20(C)]</li> <li>• 955 mm (Min) - CASNUB 22NLC</li> <li>• 840 mm - New for LCCF 20(C)</li> <li>• 780 mm - Condemn for LCCF 20(C)</li> </ul>



## Continued

<b>Sr. No</b>	<b>Features</b>	<b>Description</b>
4.	Wheel base	2000 mm
5.	Type of Axle bearing	Cartridge Tapered Roller Bearing Class “E” suitable for narrow jaw/ wide jaw adapter
6.	Distance between journal centres	2260 mm
7.	Distance between side beares	1474 mm
8.	Type of side bearers	RDSO Approved Constant contact and PU pad type side bearers.
9.	Anti-rotation features	Anti-rotation lugs have been provided between bogie bolster and side frame

# Continued

Sr. No	Features	Description
10.	Type of pivot	<ul style="list-style-type: none"><li>• CASNUB 22W(M) ,22NL, 22NLB, 22NLM, 22 HS, 22 NLC and IRF-108HS - Spherical Type RDSO Drg. No. WD-85079-S/2</li><li>• CASNUB 22HS, HS(Mod-I), HS(Mod-II)– Flat Type RDSO Drg. No. WD-97049-S/3</li></ul>
11.	Type of Brake beam	<ul style="list-style-type: none"><li>• All bogie except CASNUB 22W (M): Unit type fabricated brake beam supported and guided in the brake beam pockets.</li><li>• CASNUB 22W (M): Unit Type Cast Steel brake Beam suspended by hangers from side frame brackets.</li></ul>
12.	Suspension details	Long travel helical spring
13.	Elastomeric pads	On all types of bogies.



# Major components of Casnub

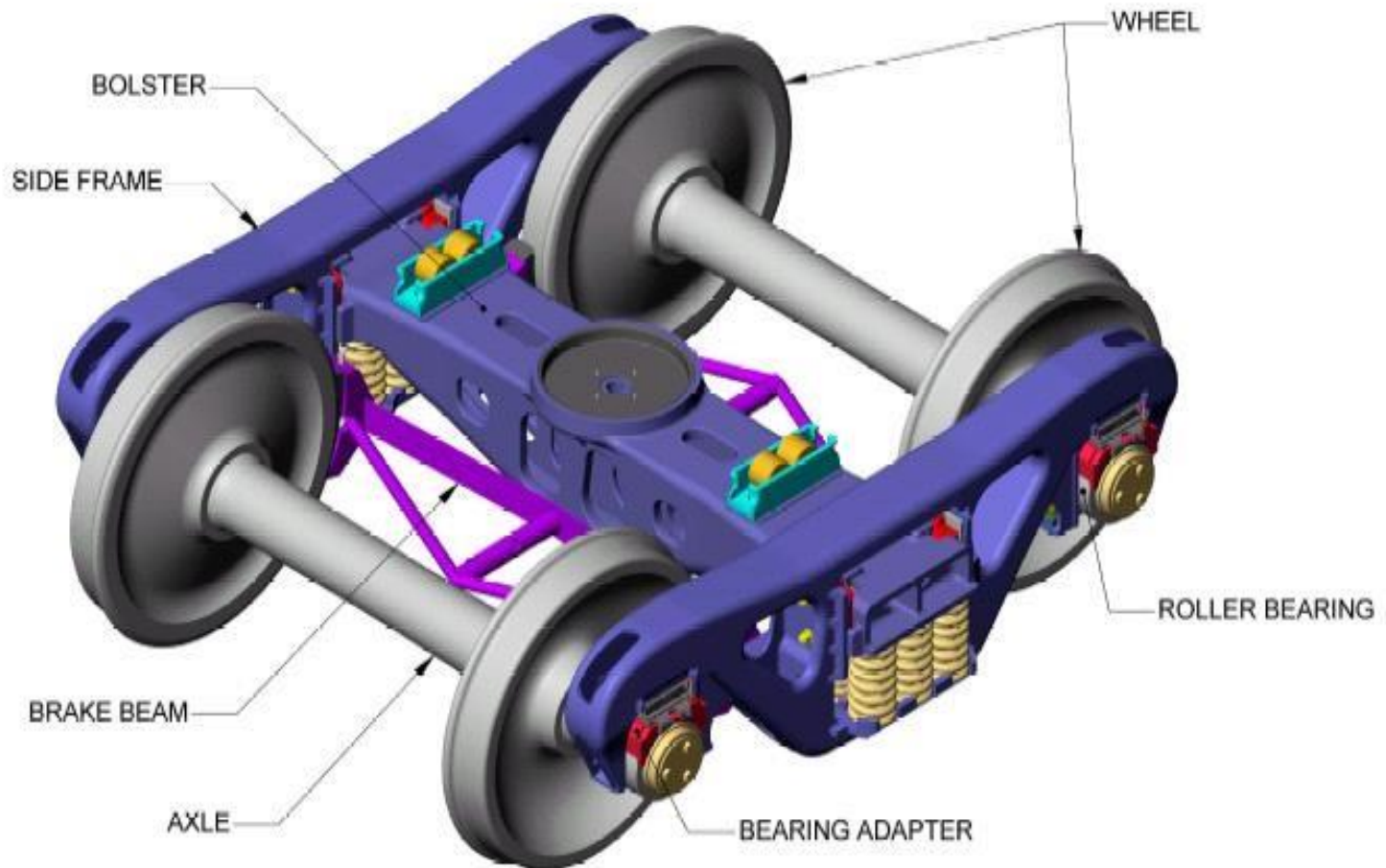

# Bogie componenets:

1. Wheel set with Cartridge Tapered Roller Bearing
2. Axle Box/Adapter, retainer bolt & side frame key assembly
3. Side frames with friction plates
4. Bolster with wear liners
5. Spring plank, fit bolts & rivets
6. Load bearing springs and snubber springs
7. Friction shoe wedges
8. Centre pivot arrangement comprising of Centre pivot top, Centre pivot bottom, Centre pivot pin, Centre pivot retainer & locking arrangement
9. Side Bearers
10. Elastomeric Pad
11. Bogie Brake Gear Assembly
12. Brake Beam

# WHEEL SET WITH CARTRIDGE TAPERED ROLLER BEARING

- Wheel diameter is 1000 mm in new condition
- Condemning diameter of wheel is 906 mm
- Fitted with standard AAR Class “E” Cartridge Tapered Roller Bearings (CTRB) (6”X11”)
- The axle box is cylindrical in shape and carries an adaptor
- The bogie frame jaw in turn rests on the adaptor

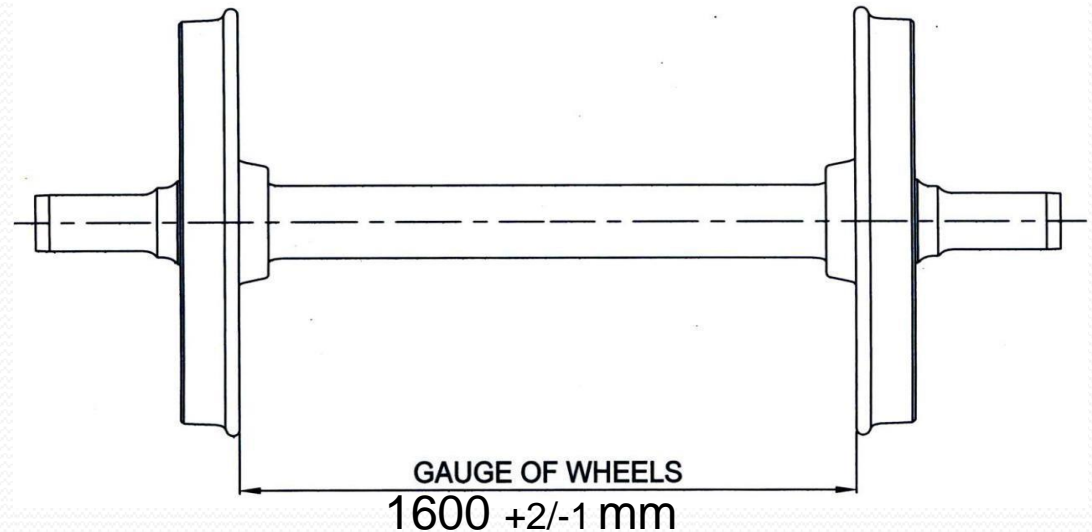
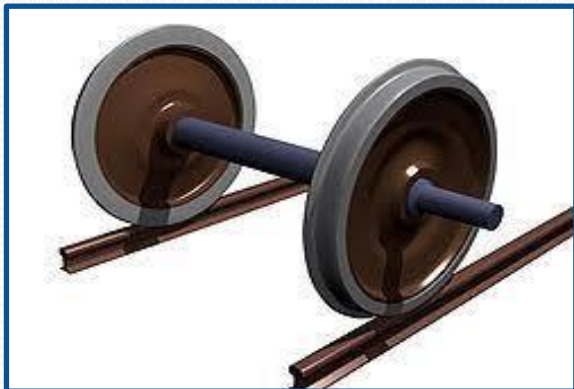



# CTRB ASSEMBLY

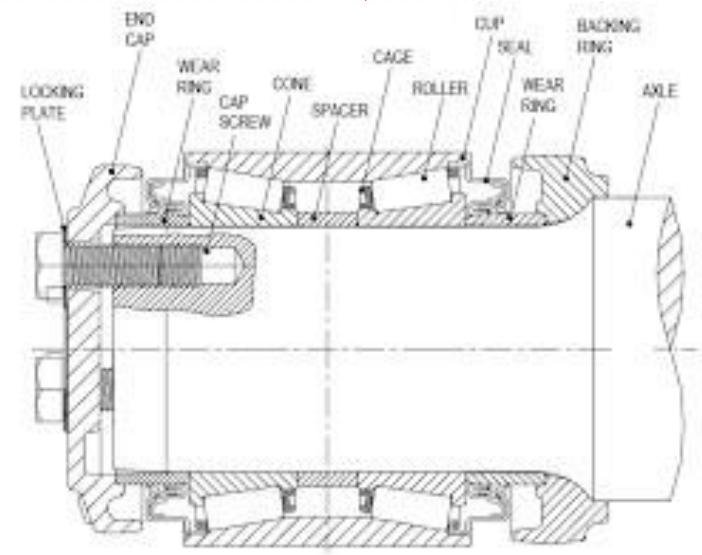
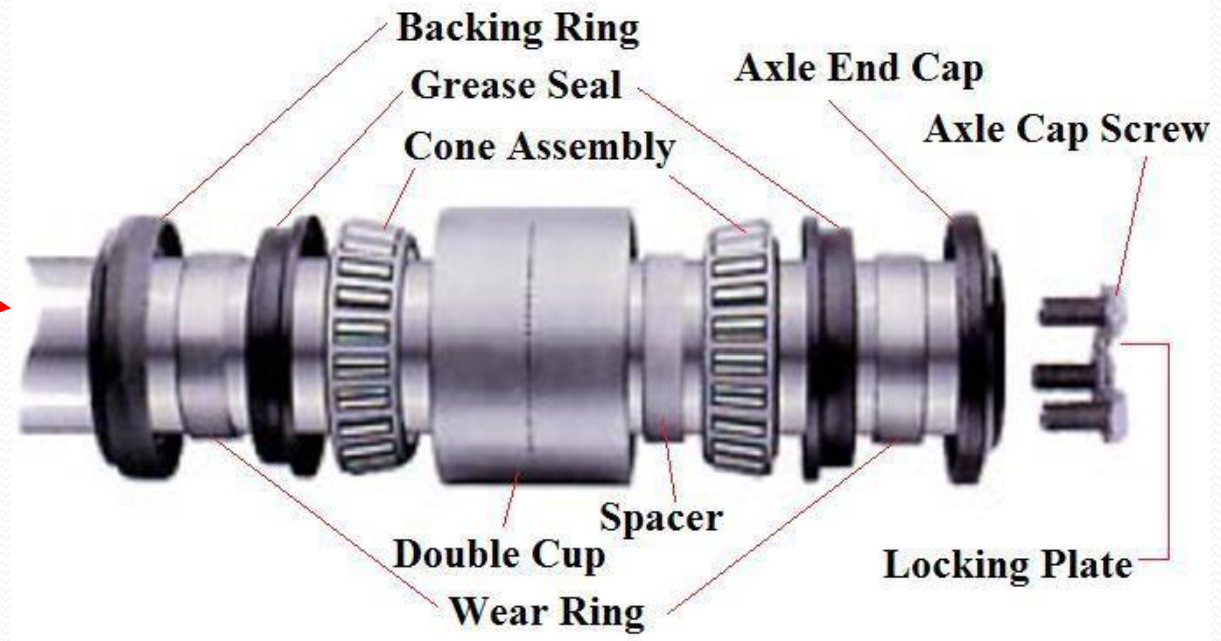

# AXLE BOX/ADAPTER:

- **CASNUB 22W & CASNUB 22W**

**(M):-** Wheel sets of these bogies are having standard AAR Cartridge Tapered Roller Bearing Class 'E' (6" X 11") with Wide Jaw adapter.

**WIDE JAW ADOPTOR** →



- In **Retrofitted CASNUB 22W** bogies, modified wide jaw adapter is used.

**MODIFIED WIDE  
JAW  
ADOPTOR** →





# Continued

- All other CASNUB type of bogie except CASNUB 22W, CASNUB 22W (M): –

Wheel sets are provided with standard AAR Cartridge  
Tapered  
Roller Bearing Class 'E' (6" X 11") with narrow jaw  
adapter

**NARROW JAW  
ADAPTOR**



## SIDE FRAME WITH FRICTION PLATES:

- The Casnub bogie consists of two Cast steel Side frames
- They are provided with jaws at the ends
- The jaws are of horn guide type used for holding and locating the Wheel and Axle box set
- The side frames have pockets for brake beam
- The side frames are provided with certain numbers of cast-buttons to facilitate selective assembly of the side frames in bogie to maintain close tolerance in the wheel base
- The side frames having the same number of buttons are to be assembled for particular bogie.

## Continued

- Side frame column has been provided with 10 mm thickness Silico Manganese Steel wear liners welded on the columns
- It must be ensured that the liners permitted in service up to a thickness of 6 mm only
- No paint or grease should be applied on the friction plate

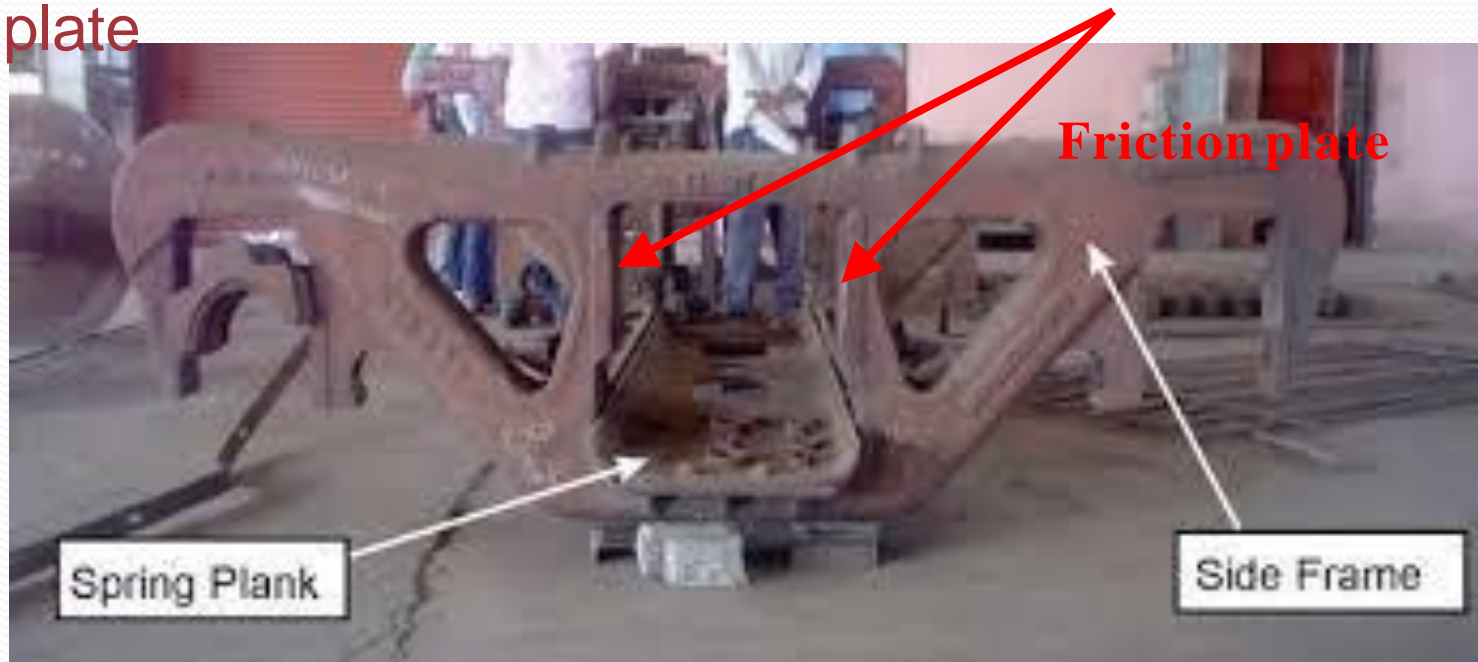



# SIDE FRAME AND BOLSTER

SIDE FRAME

BOLSTER

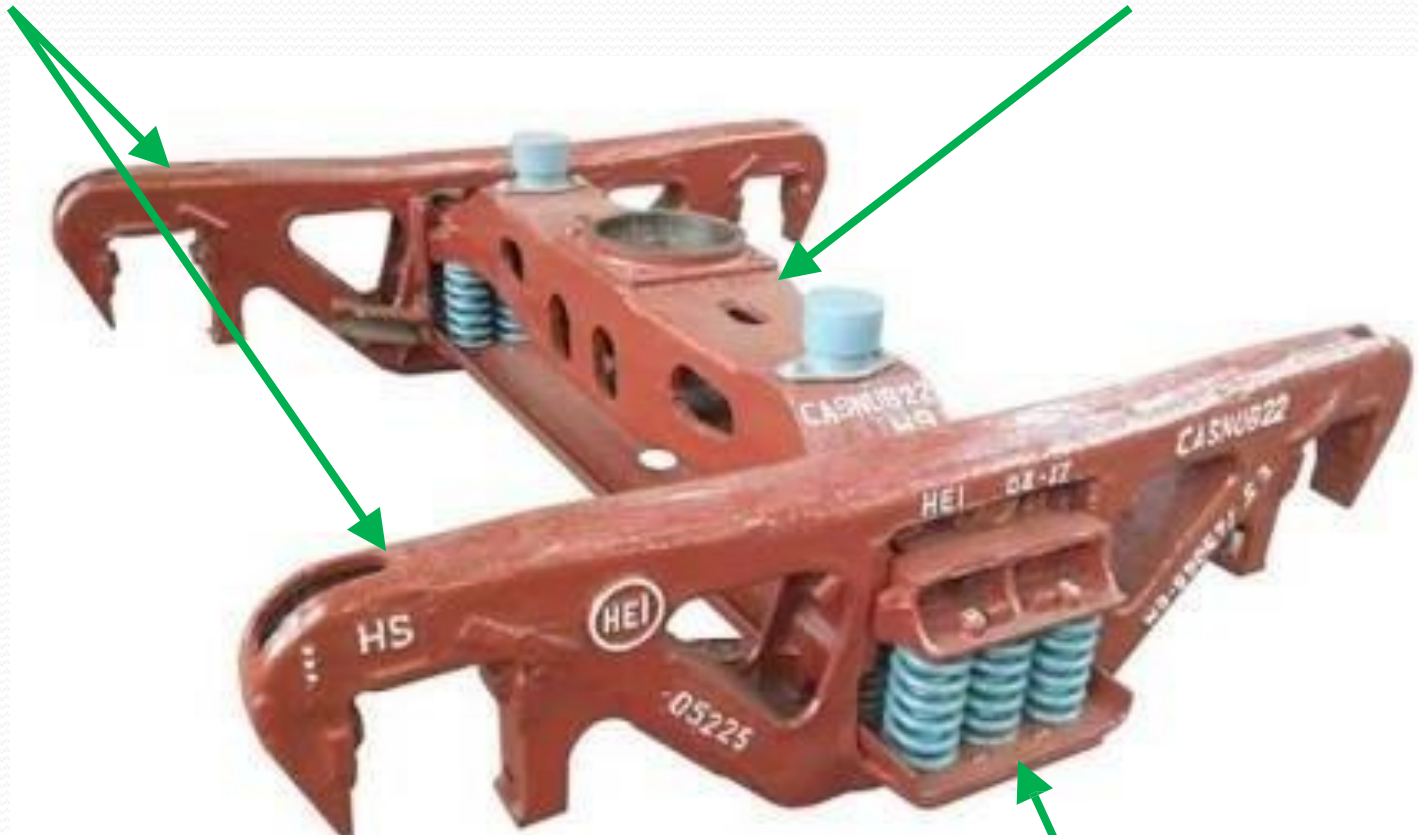

JAW

SPRING PLANK

# BOLSTER

- Cast iron floating bolster, nested springs, spring plank and friction wedge forms the secondary suspension
- It is the Cast steel body, which carries the center pivot base and two Side bearers and rests on the spring set on two sides along with the wedge block
- Load transmission from wagon to side frames takes place through it
- It forms the bogies suspension system
- Wear in liners may Provided with 8 mm thick silico manganese steel liners welded with pocket slope be permitted in service upto 3 mm
- No paint or grease should be applied on the plate



# BOLSTER

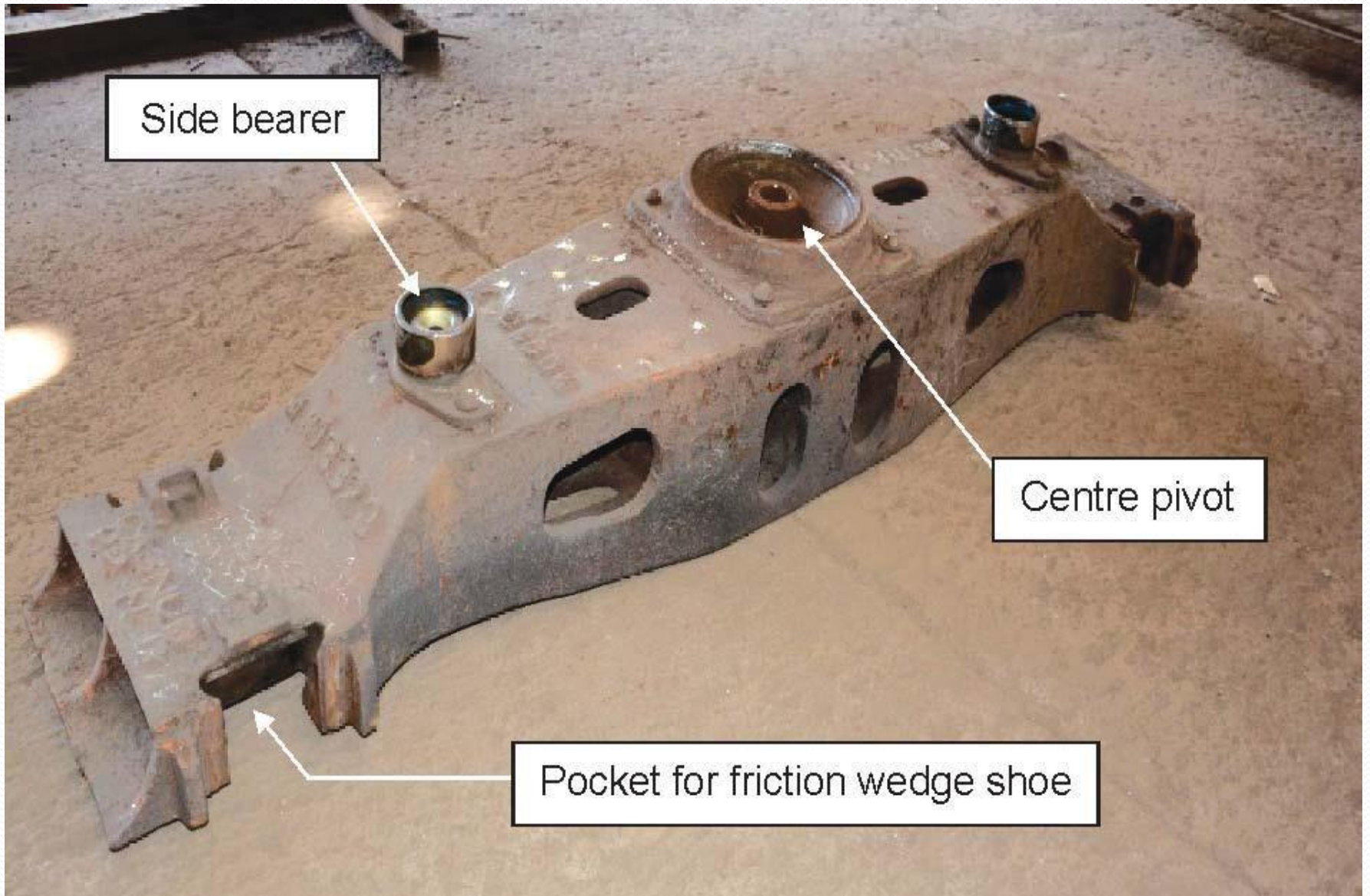

## SPRING PLANK, FIT BOLTS AND RIVETS:

- It is a solid mild steel plate (flanging quality) and connects the two side frames by eight rivets and four fit bolts to keep bogie frame square.
- The lower plank also acts as the seat for spring assemblies.
- It transfers the loads from bolster to side frame.
- It provides rigidity to bogie frame.
- Special care is to be taken regarding the use of fit bolts as well as quality of riveting.
- Fitment of spring plank with side frames should be done on suitable fixture.
- If side frames are not held in square position, then axle's longitudinal axis is not at right angle to the track and derailment may occur.



## Fitment of Lower spring plank with side frames

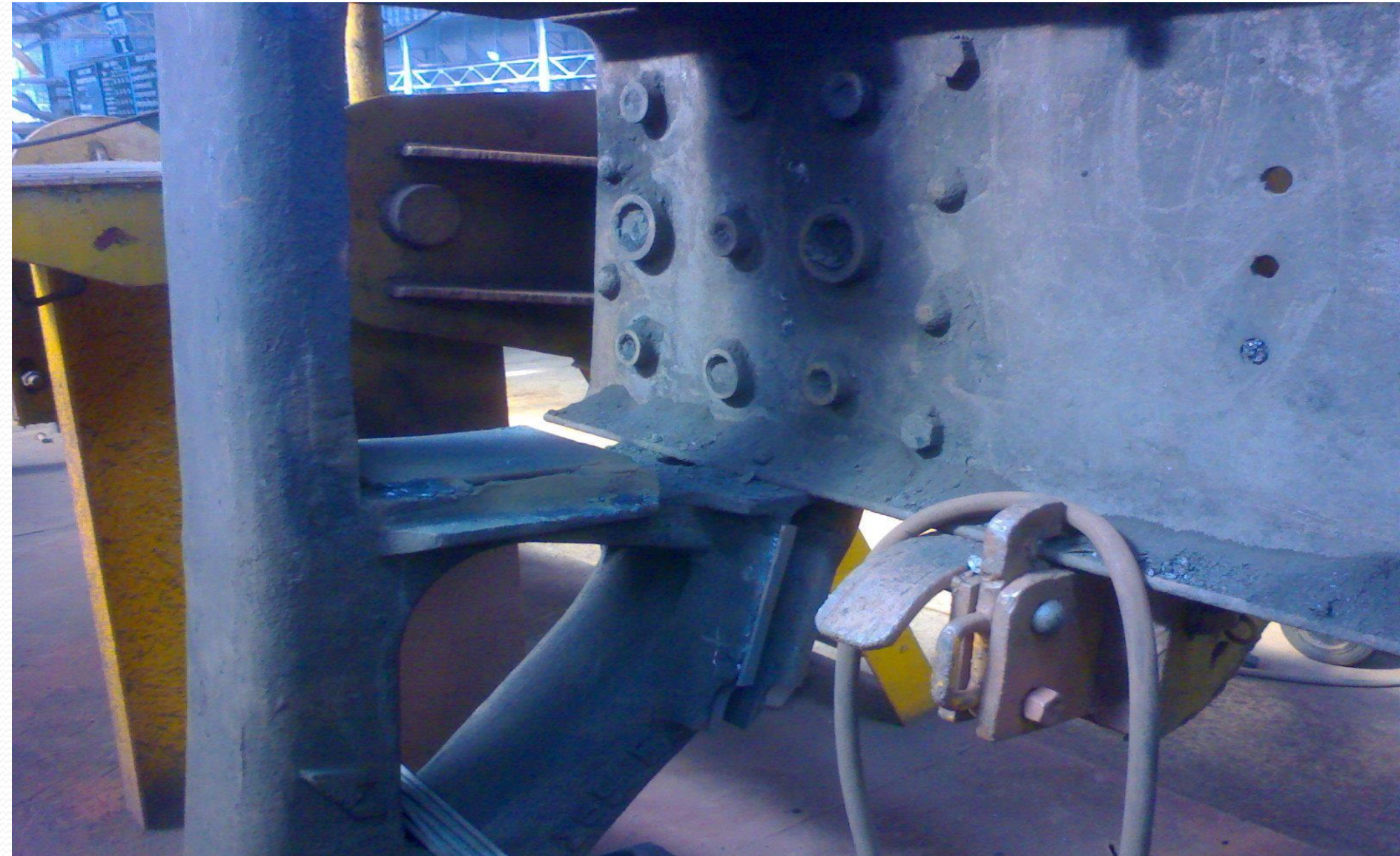



# Fitment of Lower spring plank with side frames



## SECONDARY SUSPENSION:

- The bolster is placed on the springs to form secondary suspension
- The suspension is provided with load proportional friction damping arrangement with the help of manganese steel cast wedge supported on the snubber springs
- There are different versions of Casnub bogies with different axle loads that are used in Indian Railways
- Depending upon the axle load variation, different combinations of springs are used



# Suspension System:

Secondary suspension spring

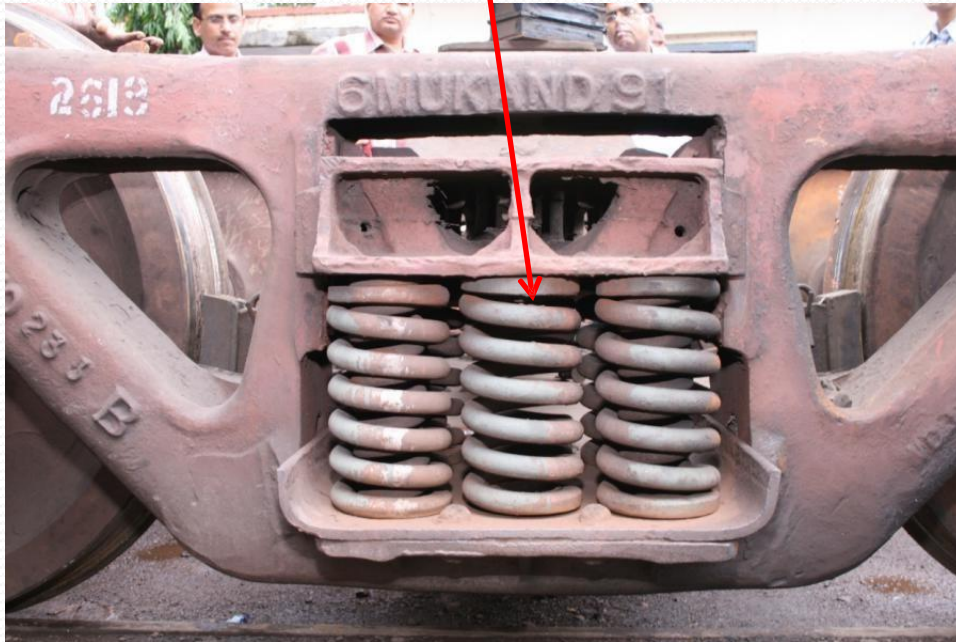

Space for Secondary suspension springs



## LOAD BEARING SPRING & SNUBBER SPRING:

- Casnub bogies are fitted with two groups of long travel helical spring nests
- These springs are provided to transfer the load from the bolster to side frame
- The springs are manufactured out of silico Manganese steel, chrome vanadium, chrome molybdenum
- The matching of load and snubber springs is important
- It is recommended that the springs should be so grouped that the free height variation in the group is not more than 3 mm
- Mixing of new and old springs should be avoided

# SPRING GROUPS PER BOGIE FOR VARIOUS AXLE LOAD:-

Type of Bogie	Axle Load	Number of Springs		
		Outer	Inner	Snubber
CASNUB 22 W(M), NL, NLB, NLM	20.32t	12	8	4
CASNUB 22 W(M), NL, NLB, NLM	CC+8t+2t	14	10	4
CASNUB 22HS	20.32t	14	12	4
CASNUB 22HS	CC+6t+2t & CC+8t+2t	14	14	4
CASNUB 22HS(Mod-I)	20.32t	12	12	4
CASNUB 22HS(Mod-II)	22.32t	12	12	4
CASNUB 22NLC	25t	14	14	4
IRF-108HS	22.82t/23.5t	14	14	4



# SPRING GROUP

WX05100B.

ANNEXURE- IIA

## SPRING GROUPS FOR VARIOUS AXLE LOADS

AXLE LOAD		22.9 TONNES			20.32 TONNES		
SPRING GROUP FOR EACH END OF BOGIE BOLSTER							
NUMBER OF SPRINGS PER GROUP		OUTER (7)	INNER (7)	SNUBBER (2)	OUTER (7)	INNER (6)	SNUBBER (2)
TEST LOAD ON BOGIE PIVOT & HEIGHT OF C.P TOP FROM R.L	CONDITION	LOAD (t)		HEIGHT (mm)	LOAD (t)		HEIGHT (mm)
	TARE	6.066		$932^{+3}_{-8}$	6.066		$932^{+3}_{-8}$
	GROSS	40.38		$892^{+3}_{-8}$	35.22		$895^{+3}_{-8}$
	50% OVER LOAD	60.57		$870.5^{+3}_{-8}$	52.83		$874.5^{+3}_{-8}$
DETAILS OF SPRINGS		WD-92058-S/5, OUTER ITEM-1, INNER ITEM-2, SNUBBER ITEM-3					

# SNUBBING ARRANGEMENT

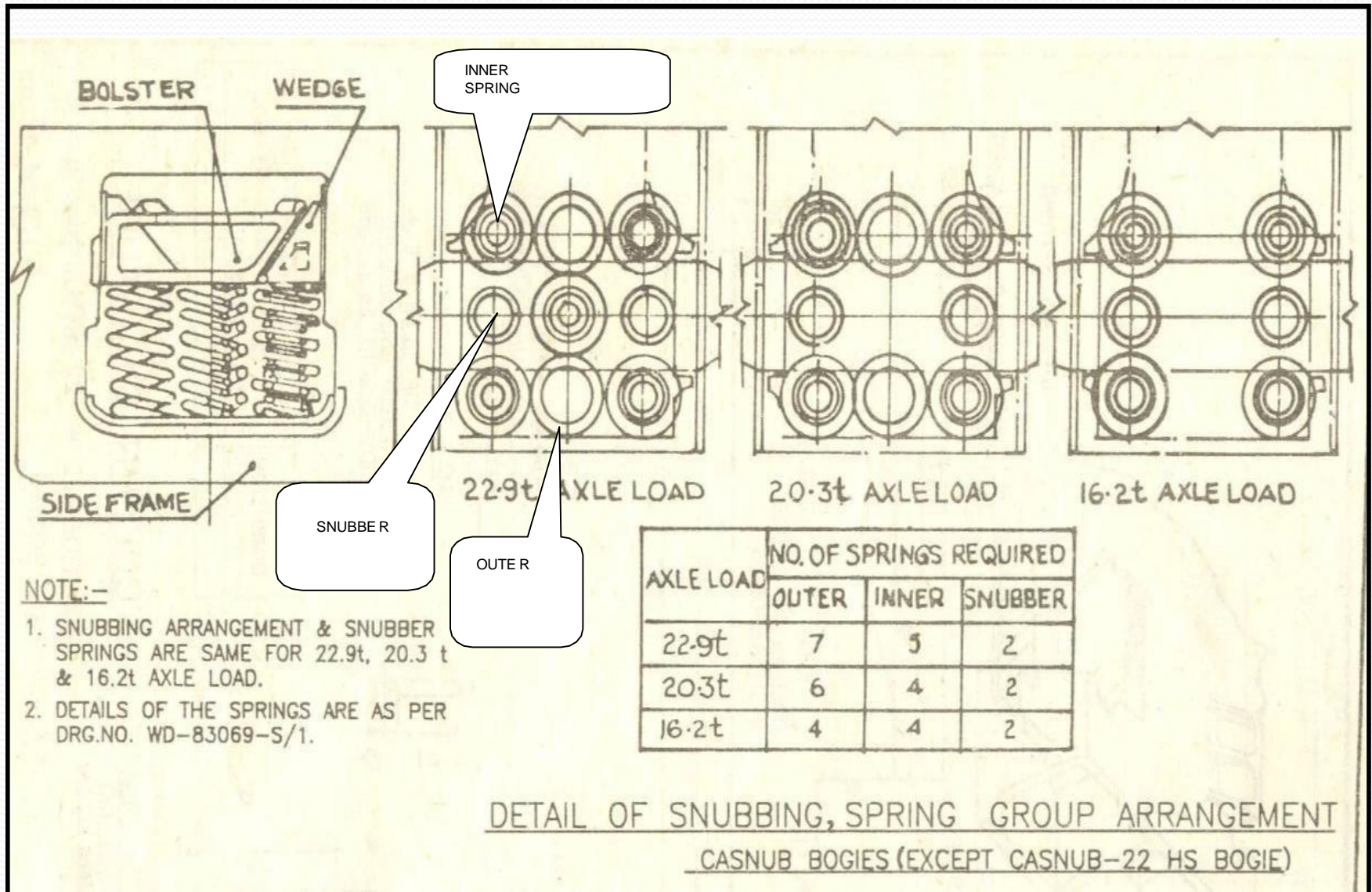

# 1. SPRING ARRANGEMENT- CASNUB 22 HS

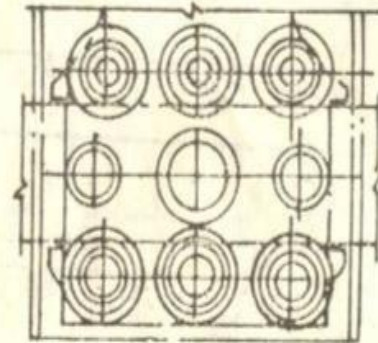
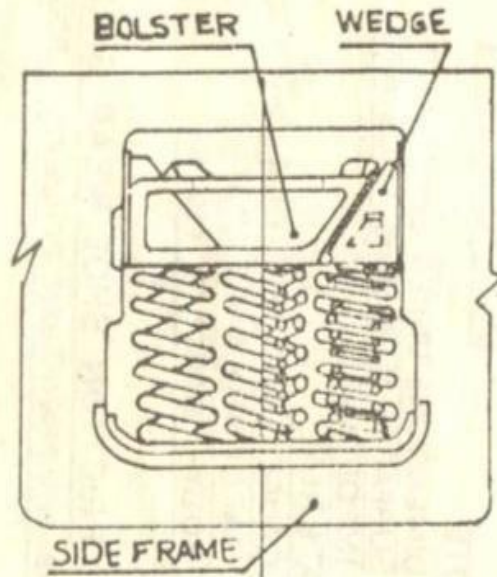

AXLE LOAD	NO. OF SPRINGS REQUIRED		
	OUTER	INNER	SNUBBER
20.3t	7	6	2

## NOTE:

1. DETAILS OF THE SPRING ARE AS PER DRG.NO. WD-92058-S/5

DETAIL OF SNUBBING SPRING, GROUP ARRANGEMENT  
(CASNUB-22 HS BOGIE)



# SPRING ARRANGEMENT

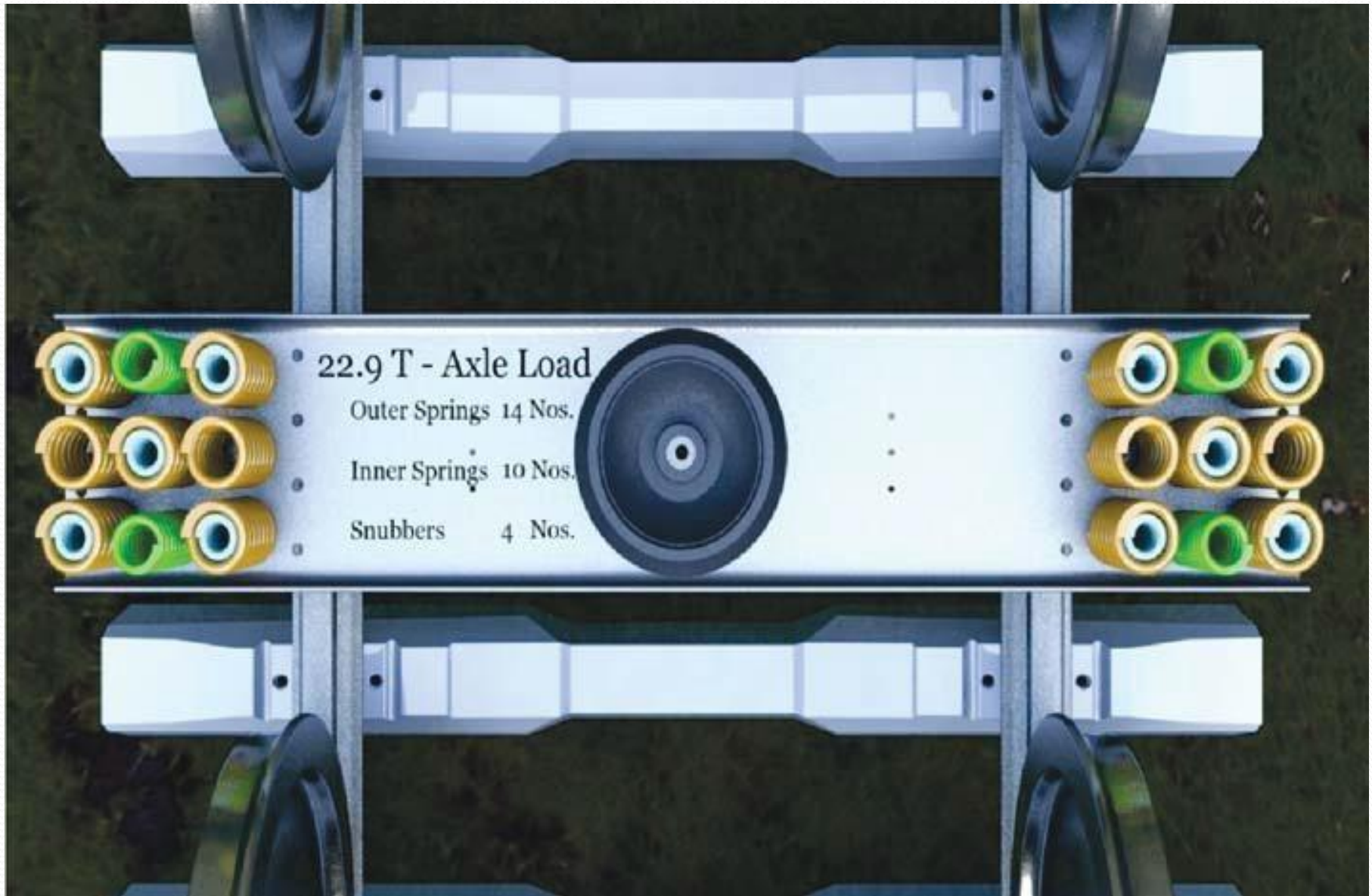

**SPRING  
NEST**



**SPRING  
GAUGING**



Use of Gauges for grouping of Springs



### 609. Arrangement of springs in various CASNUB trolleys according to axle load

Type of wagon	Type of trolley	Spring nest arrangement for 20.32 t axle load	Modified Spring nest arrangement for 22.9 t axle load (M1)	Spring nest arrangement for 25t axle load (with NLB trolley only) EL / (BOBSNM1)
BOXN BOXNR BOXNCR BCN BCNA BOBRN BOBSN BOY BOBYN	22W, W(M), NL, NLM, NLB,			
BOXNHS BOXNLW BOXNHL BOST BCNAHS BCNHL	22HS			NA
BOSTHS	22HS (Mod-1)			NA
BOXNHA	IRF108HS			NA
BRN BRNA BTPN BTPGLN	22NLB		NA	NA



BRNAHS BFNS BRHNEHS	22HS		NA	NA
BLCA/BLCB	LCCF20		NA	NA

\*NA= Not applicable

**(a) Nomenclature of Bogie:**

W	M	N	L	B	HS
Wide Jaw	Modified	Narrow Jaw	Light weight	Belly shaped bolster	High Speed

**Load Bearing springs and snubber springs:**

CASNUB bogies are fitted with two groups of long travel helical springs nests. The spring group for bogie for various axle load application are shown in fig below.

Spring details are shown in WD 89069-S/1 (Common for all versions except Casnub - 22HS Bogie). The spring details for Casnub - 22 HS bogies are shown in WD - 92058-S/5.

**Damping:** The suspension is provided with load proportional friction damping arrangement with the help of Mn steel Cast Wedge supported on the snubber springs. The details of the snubbing arrangement are shown in fig below.

## (b) Grouping of Springs: (By strip method)

### A. Group Band (Coloured) for in service springs (Maintenance group)

Matching of both, load and snubber springs, is important. It is recommended that springs having **not more than 3 mm free height variation** should be assembled in the same group. Coloured band should be provided for easy identification of group height as indicated in the table.

All versions (except for CASNUB 22 HS)

No. of Bands	Outer	Inner	Snubber
I	260-257	262-259	294-291
II	257-254	259-256	291-288
III	254-251	256-253	288-285
IIII	251-248	253-250	285-282
Red	248-245	250-247	282-279

### CASNUB 22 HS

Group	Outer	Inner	Snubber
I	260-257	243-240	293-290
II	257-254	240-237	290-287

III	254-251	237-234	287-284
III	251-248	234-231	284-281
Red	248-245	231-228	281-278

#### CASNUB 22 HS (Mod-1)

Group	Outer	Inner	Snubber
I	253-250	225-222	304-301
II	250-247	222-219	301-298
III	247-244	219-216	298-295
III	244-241	216-213	295-292
Red	241-238	213-210	292-289

#### B. Group Band (Coloured) of NEW Springs,

Matching of both, load and Snubber springs, is important. It is recommended that springs having **less than 3 mm free height variation** should be assembled in the same group.

All versions (except for CASNUB-22 HS)

Ref: DRG No.WD-83069-S/1

No. of Bands	Outer	Inner	Snubber
I	263-261	265-263	297-295
II	261-259	263-261	295-293
III	259-257	261-259	293-291

CASNUB- 22 HS,

Ref: DRG. No.WD-92058-S-5

Group	Outer	Inner	Snubber
I	263-261	243-241	293-291
II	261-259	241-239	291-289
III	259-257	239-237	289-287

CASNUB -22HS (Mod-1) BOSTHS,

Ref: DRG No. WD-04017-S/4

Group	Outer	Inner	Snubber
I	256-254	228-226	307-305
II	254-252	226-224	305-303
III	252-250	224-222	303-301

\*\* Mixing of new and old springs should be avoided



# SPRING DATA:

Type of spring	Coil Dia. (mm)	Free height (mm)	Condemning limit (mm)
All vesions (except for CASNUB-22HS)			
Outer	25	260	245
Inner	16	262	247
Snubber	16	294	279
CASNUB-22HS			
Outer	22	260	245
Inner	18	243	228
Snubber	18	293	278
CASNUB -22HS(Mod-1) BOSTHS			
Outer spring	21.5	253	238
Inner Spring	16.5	225	210
Snubber Spring	16.5	304	289

# LOAD & SNUBBER SPRING ARRANGEMENT:-

<b>Bogie Type</b>	<b>SPRINGS</b>	<b>Spring free height nominal (mm)</b>	<b>Recommended free height condemning (mm)</b>
CASNUB 22 W, W(Retro), W(M), NL, NLB, NLM & NLC	Outer	260	245
	Inner	262	247
	Snubber	294	279
CASNUB 22HS	Outer	260	245
	Inner	243	228
	Snubber	293	278
CASNUB 22HS(Mod-I)	Outer	253	238
	Inner	225	210
	Snubber	304	289

# Continued

<b>Bogie Type</b>	<b>SPRINGS</b>	<b>Spring free height nominal (mm)</b>	<b>Recommended free height condemning (mm)</b>
CASNUB 22HS(Mod-II)	Outer	253	238
	Inner	222	207
	Snubber	304	289
IRF-108HS	Outer	264	249
	Inner	246	231
	Snubber	296	281
LCCF-20(C)	Outer	260	245
	Inner	243	228
	Snubber	288	273



# FRICTION SHOE WEDGES AND SNUBBER SPRING:

- Friction shoe wedges are fitted on Snubber springs
- Its vertical surface is with side frame
- Its slope surface is in contact with bolster pocket liners
- The oscillations develop in the wagon when it moves on the track, due to unevenness in the track geometry
- These oscillations should be dampened else resonance will occur, resulting in the occurrence of high amplitude of oscillations
- Here, friction shoe wedges and Snubber springs form the damping mechanism, acting as a damper

WEDGE BLOCK

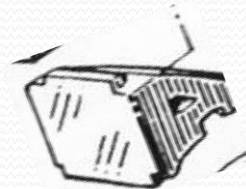
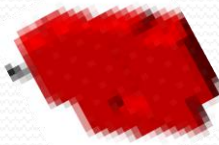

# High Performance Friction Wedge

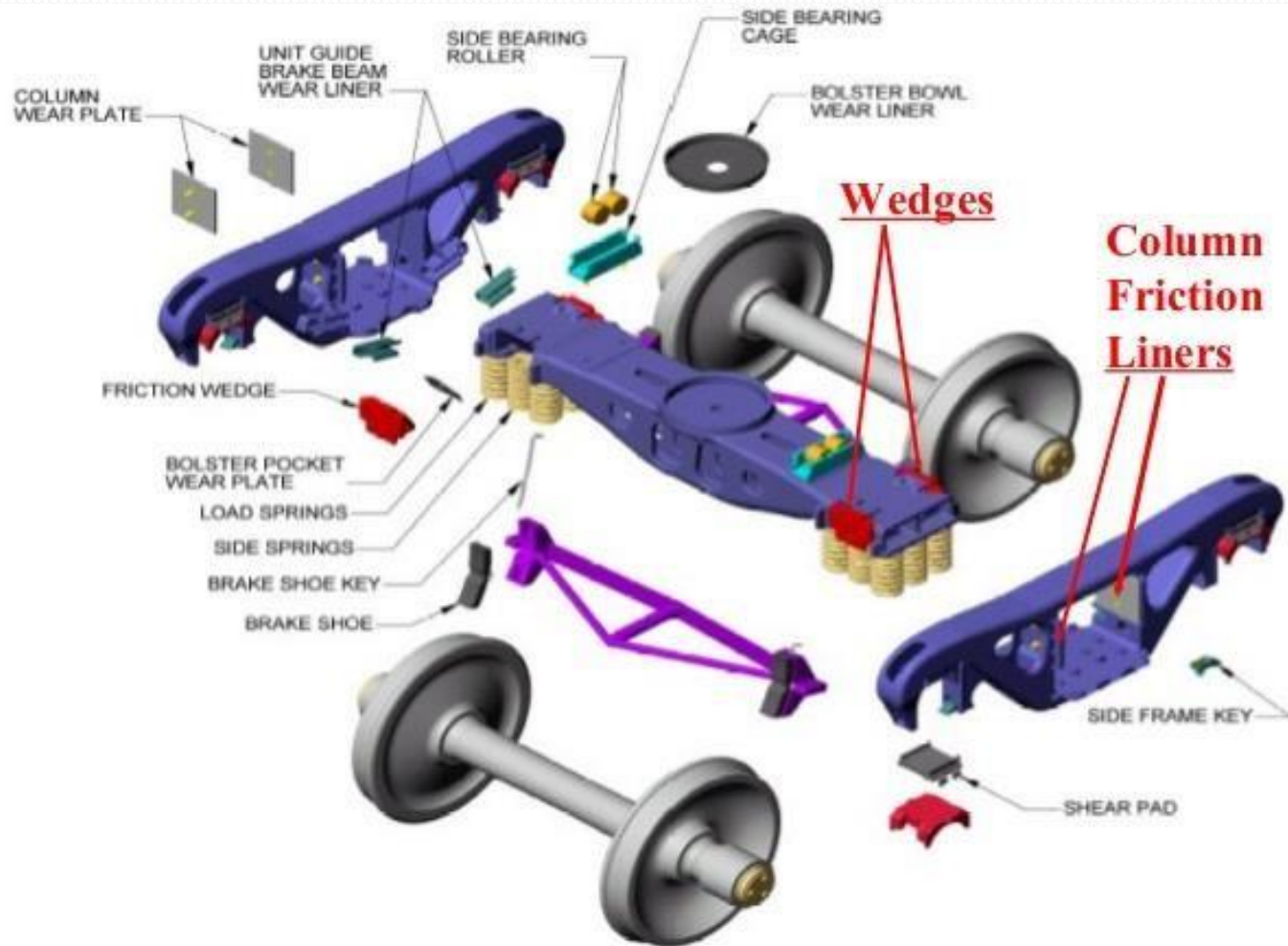

# EXPLODED ASSEMBLY VIEW

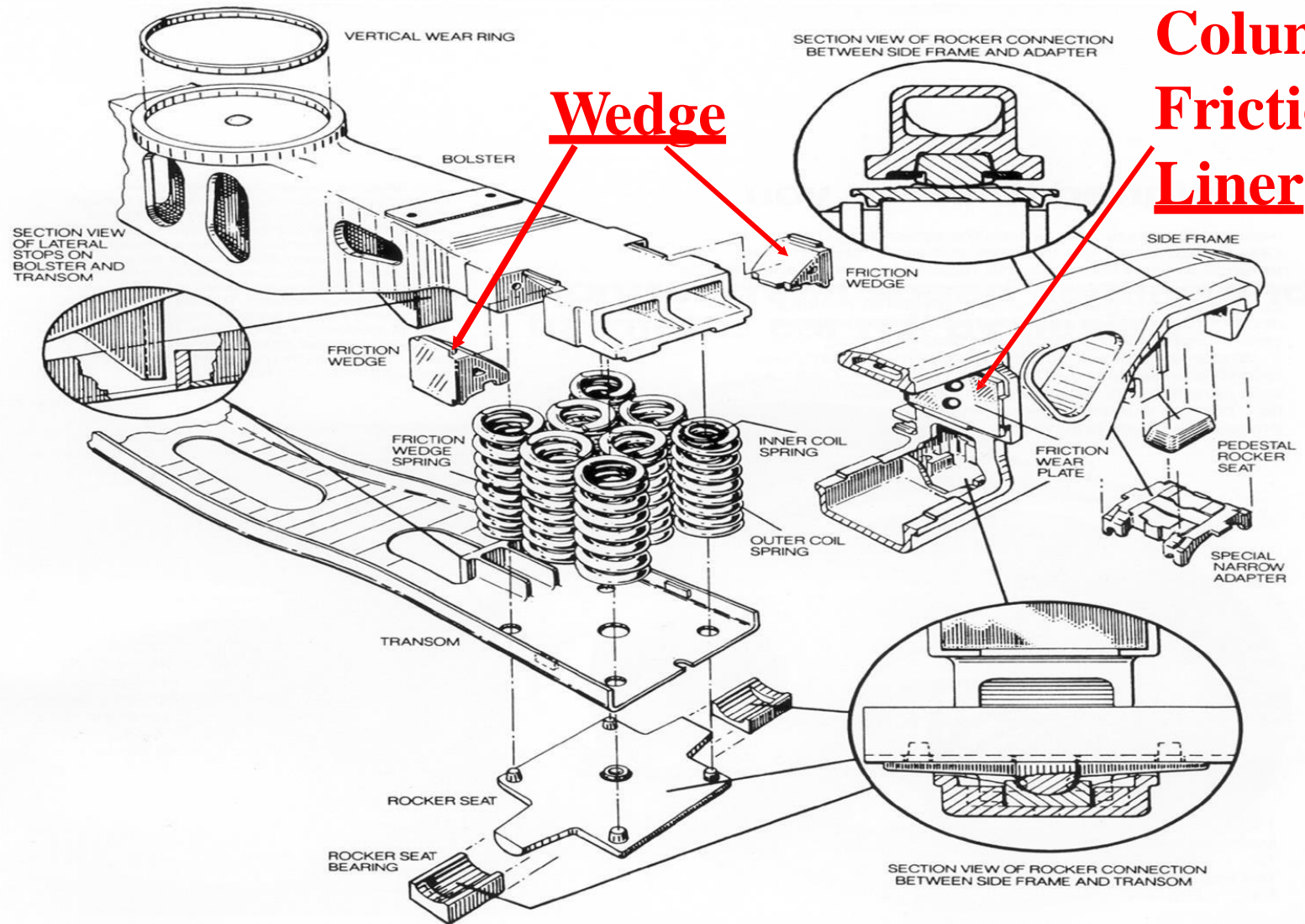



# CENTRE PIVOT ARRANGEMENT:

- Load from wagon is transferred to bolster through centre pivot provided at the center of bolster
- Wagon when negotiating a curve and turnouts bogie rotates about centre pivot
- Centre pivot provides relative rotation of bogie frame in the horizontal plane of wagon which avoids development of flange forces causing persistent angular run
- Braking and tractive forces are also transferred to bogie through pivot pin

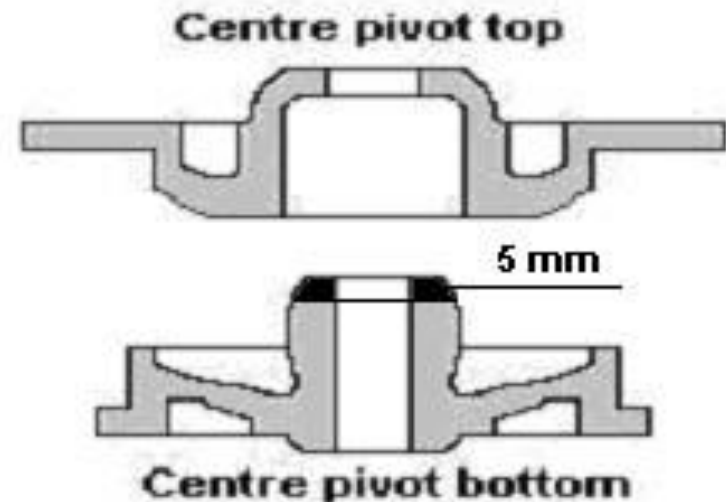

# CENTRE PIVOT BOTTOM



**RIVETED WITH BOGIE BOLSTER**

# CENTRE PIVOT TOP



**RIVETED WITH BODY BOLSTER**

# TWO TYPES OF CENTRE PIVOT ON BOLSTER:

**Spherical type Centre pivot rivetted to bolster**



**Integral flat type centre pivot**





# SIDE BEARERS:

- RDSO approved constant contact and PU pad type side bearers are used
- Cast steel housing for both side bearers are riveted/bolted on bolster
- Bogie, while negotiating curve, rotates about pivot pin, side bearers provides smooth rotation bogie in horizontal plane

□ Different types of side bearers used in CASNUB bogie are:

1. **Roller type side bearer** – Was used in Casnub 22W bogie

Such side bearers has been replaced by Metal bonded rubber pads

2. **Constant contact type side bearer**

(i) Metal bonded Rubber pads

– Used in Casnub 22W(R), W(M), NL, NLM, NLB

(ii) PU pad type side bearer

– Used in Casnub 22 HS M-I/M-II, NLC

3. **Helical spring loaded side bearer**

-Used in Casnub 22HS, IRF 108 HS, LCCF-20(C)

Such side bearers has been replaced by PU pad type side bearer

## CAST STEEL HOUSING FOR SIDE BEARER





# SIDE BEARER

Used with this version is metal bonded rubber pad maintaining constant contact with the body



Used with this version is PU side bearer pad maintaining constant contact with the body





# PU PAD TYPE SIDE BEARER

- The PU (Polyurethane) side bearer pad consists of two top bottom fabricated housing
- The PU rings are placed alternatively between steel plates
- The size of PU ring is dia. 109.5 mm x dia. 40 mm x 31.5 mm
- PU side bearer is much more sturdier than rubber bonded side bearer pad
- The failure of PU side bearer is much lesser than rubber bonded pads
- Hence, all wagons fitted with constant contact type side bearer, should be converted with PU side bearer vide RB's L/No. 2004/M(N)/ 951/14/ Vol-I dated 17-06-09

**For easy identification of wagon both side of wagon body shall be painted by “yellow” colour between top coping and middle coping**

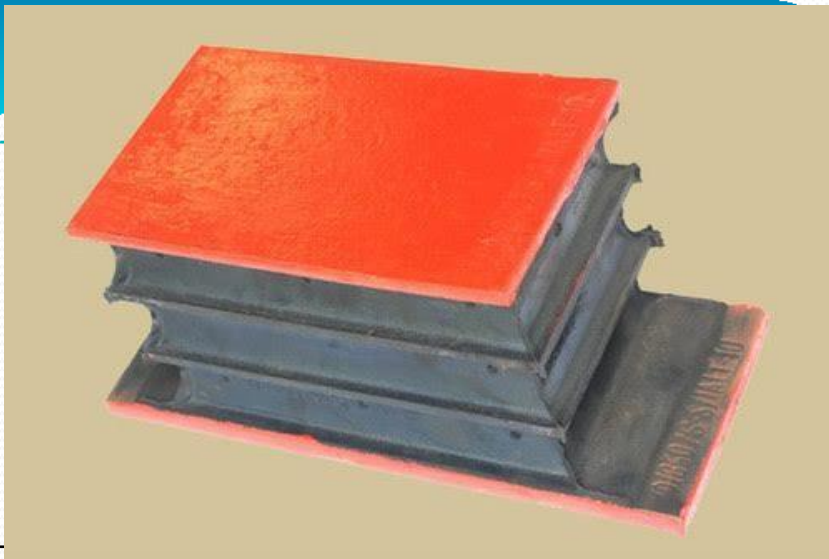

**METAL BONDED SIDE BEARER**



**PU PAD SIDE BEARER**



**DISAMBLLED PU SIDE BEARER**



**ARRANGEMENT OF PU PADS**







# PU Side bearer (modified)

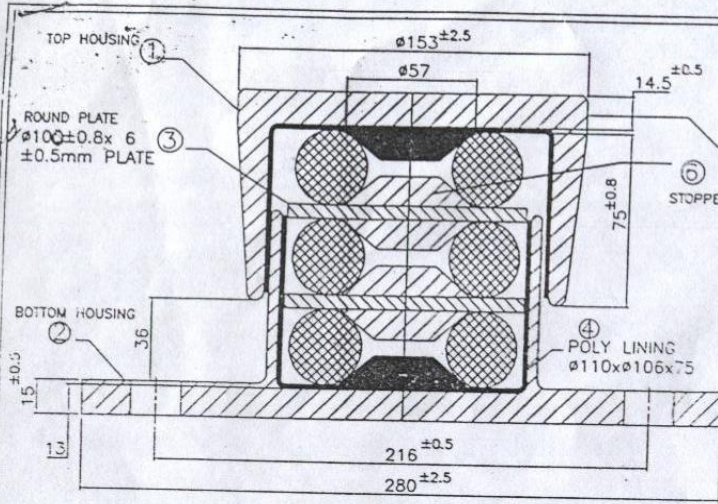

SECTIONAL ELEVATION

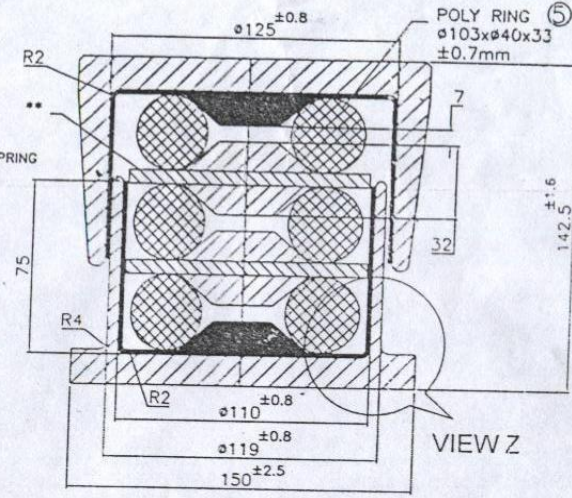

VIEW Z

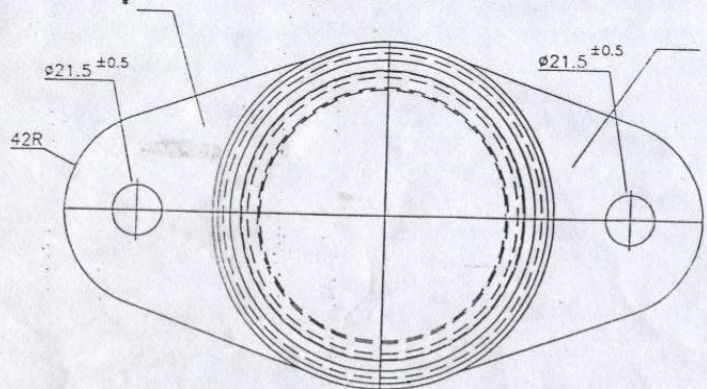

PLAN

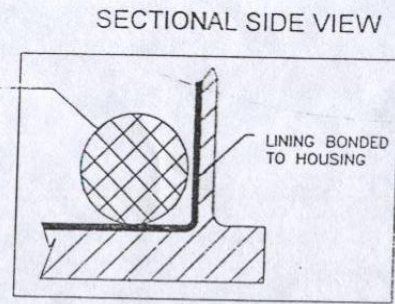

VIEW Z SCALE 1:1.5

- ALT.1 Forged or Cast Steel Top & Bottom Housing is used instead of fabricated one.
- ALT.2 Only Forged Steel Top & Bottom Housing is used.
- ALT.3
  1. Tolerances Added.
  2. Item No. 6 material changed to mild steel (S:2052, Fe 410 WA)
- ALT.4
  1. Item No.6 Removed.
  2. Top Housing Outer is as received after forging
  3. Height of Pad changed to  $142 \pm 1$  from  $143 \pm 1$
- ALT.5
  1. Height of pad changed from  $142 \pm 1.0$  to  $142.5 \pm 1.6$ .
  2. Ring changed from  $31.5 \pm 1.3$  to  $33 \pm 0.7$
  3. Plate Thickness Tolerance changed from  $\pm 0.75/0.3$  to  $\pm 0.5$ .
  4. Top Housing Thickness 20.0mm changed to  $16.5 \pm 0.5$  mm.
  5. Bottom Housing Thickness changed from  $16.0 \text{ mm} \pm 15.0 \text{ mm} \pm 0.5$ .
  6. Static Load Deflection characteristics : Deflection Value at a load of 2.7 tonnes changed from 17-18 mm to 18.5-20.5 mm.
- ALT.6
  1. Nomenclature changed to Constant Contact Polymer Side Bearer Assy. from Polymer Pad Side Bearer Assy.
  2. Top & Bottom Housing cut to accommodate 2 mm lining
  3. Spacer Plate OD changed to  $\phi 100$  from  $\phi 108$  and PU stopper spring moulded to spacer plate.
  4. PU Internal Lining of 2mm bonded to Bottom & Top Housing added.

NO.	ITEM	DESCRIPTION	SPECIFICATION	WEIGHT
1.	TOP HOUSING	FORGED STEEL	S:1875 CL-N/EN-9/EN-8	
2.	BOTTOM HOUSING	FORGED STEEL	S:1875 CL-N/EN-9/EN-8	
3.	ROUND PLATE	STEEL	S: 2052 Fe 410 WA	
4.	POLY LINING	DESUPON TPU	ELASTOMER	
5.	POLY RINGS - 3	POLYURETHENE	ELASTOMER	
6.	STOPPER SPRING	POLYURETHENE	ELASTOMER	

STATIC LOAD DEFLECTION	
LOAD (tonne)	DEFLECTION(mm.)
2.7	18.5-20.5
STIFFNESS: 138.37 Kg/mm	

6	23.03.06			
5	20.06.05			
4	24.03.05			
3	04.02.05			
2	14.08.04			
1	05.07.03			
ALT No.	DATE	DRAWN BY.	CHECKED BY.	APPD. BY

AVACH RUBBER LTD.  
 ARYAN EXPORTERS (P) LTD.  
 PRAG IND (INDIA) PVT. LTD.  
**FOR HS BOGIES**  
 CONSTANT CONTACT POLYMER  
 SIDE BEARER ASSEMBLY  
 DRG. No. AAL-021101

\* MARKED MFR. INITIAL, MONTH-YEAR, DRG. NO.  
 \*\* MARKED MFR. INITIAL ON PU RINGS & SPACER PLATE

ALL DIMENSIONS ARE IN MM



# ELASTOMERIC PAD:

- Elastomeric pads are provided in all versions of CASNUB bogies except Casnub 22 W
- It is used between bogie frame and adapter fitted on the CTRB
- The main purpose of providing elastomeric pad is to reduce wheel flange wear

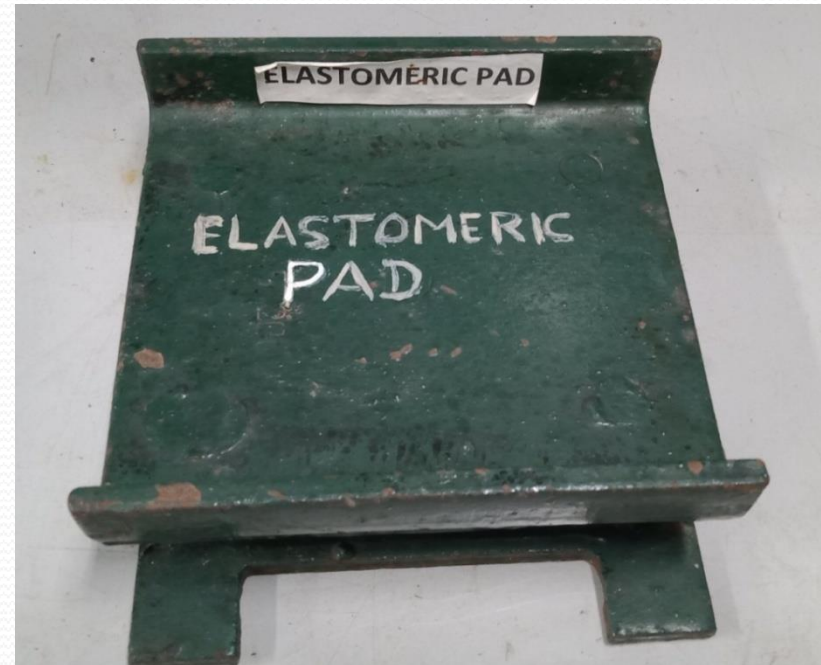

## ELASTOMERIC PADS & CONSTANT CONTACT SIDE BEARER:

Type of Pad	Free Height	Condemning Free Height
Elastomeric Pad	46+1 mm	42 mm
Constant Contact Side Bearer Pad		
(a) Metal bonded Rubber pad	114 +3/- 0 mm	109 mm
(b) PU side bearer (Three Rings)	142.5+1.6 mm	137 mm
(c) PU side bearer (Two Rings)	134+1.5 mm	128.5 mm



## BOGIE BRAKE GEAR:

- The brake gear mainly consists of Brake Beam (with brake head and brake block assembly), equalizing levers, Push rod, End pull rod etc
- It also consists pins, bushes and washer
- The maximum permissible wear on the pin diameter and bush inside diameter is limited to 1.5 mm
- In service as the tread diameter of wheel decreases due to wear, pins located in End Pull Rod with under frame to be relocated

# BRAKE BEAM:

## CASNUB 22W(M) Bogie

- The bogie is fitted with unit type suspended cast steel brake beam
- The brake head is a separate sub assembly which is fixed with brake beam circular end by means of pin passing through brake beam end and brake shoe adjuster along with spring loaded brake head
- Assembly provides rotational flexibility to brake head



## NOMINAL CLEARANCES AND TOLERANCES OF THE BOGIE ASSEMBLY:

Description	22W, 22W (RETRO)	22W(M)	22NL , NLB, NLM, NLC	22HS, HS(MOD1), HS(MOD2), IRF108HS	LCCF- 20(C)
Lateral clearance between side frame and bolster	18 mm	18 mm	18 mm	25 mm	25 mm
Lateral clearance between side frame and axle box/adopter	25 mm	25 mm	16 mm	16 mm	25 mm
Longitudinal clearance between side frames and axle box/adopter	2 mm	10 mm	9 mm	9 mm	10 mm
Longitudinal clearance between side frame and bolster	6 mm	6 mm	6 mm	6 mm	6 mm



# LOAD DISTRIBUTION

