

## COOLING WATER SYSTEM (ALCO)

After combustion of fuel in the cylinder, about 25% to 30% of heat produced inside the cylinder is absorbed by the components surrounding the combustion chamber i.e. Piston, Cylinder Liner, Cylinder Head, etc. Unless the heat is taken away from them, the components are likely to fail under thermal stresses. All internal combustion engines are provided with cooling system, designed to cool the excessively hot components, distribute the heat to other surrounding components to maintain uniform temperature throughout the engine and finally dissipating the excess heat to atmosphere to keep the engine temperature within suitable limits.

The Loco (WDM2/WDM2C/WDG2/WDG3A etc) is having closed circuit pressurized water cooling system for the engine. The system is filled in by 1210 Ltrs.of demineralised water treated with corrosion inhibitor in two interconnected expansion tanks (Capacity 155 ltrs. each) on the top of the locomotive. The corrosion resistant chemical compound is HPCL Power cool. This is provided to prevent the effect of the following problems like (i)scale formation inside the radiator tube, which may reduce the water pathway and thus reduce the heat dissipation, also it acts as non-conductive surface that restricts heat dissipation; (ii) lesser heat dissipation due to bubble formation in the water jacket around the exterior surface of the cylinder liner due to high exhaust temperature, which in turn create a non-conductive layer around cylinder liner and heat dissipation becomes lesser. 36 litres of HPCI power cool added in the system.

A centrifugal pump, located at the free end bottom side of the engine, driven by the engine crankshaft through a gear, suck water from the system and deliver through the outlet under pressure (out let pressure 2.2 Kg/cm<sup>2</sup> to 2.6 Kg/cm<sup>2</sup> & discharge rate 2457 Ltrs per minute). The outlet of the pump is connected with three way flange type connector/elbow.

- One end connected to the left bank of the cylinder block. A diversion is also taken from this line for circulation through the after-cooler to cool the charge air for engine. Water from the after-cooler then returns to the same line to enter the engine block and circulate around cylinder liners, cylinder heads on the left bank and then pass on to water outlet header. Individual inlet connection with water jumper pipes and outlet by water riser pipes are provided to each cylinder head for entry and outlet of water from the cylinder head to the water outlet header. Water then proceeds to the right radiator through a bubble collector that is provided to collect the air bubbles formed due to evaporation and passes them on to the expansion tank to avoid air lock in the system and release its heat to the atmosphere before circulation to the engine.
- The other end connection leads to the right bank of the cylinder bank. After cooling the cylinder liners, heads, etc on the right bank, it reaches the left side radiator. Before it enters the radiator, a connection is taken to the water temperature manifold, where a temperature gauge is fitted to indicate the water temperature. Three other switches **ETS-1, ETS-2 & ETS-3** are also

provided. **ETS-1** is for start rotation of radiator fan at low speeds through eddy current clutch at 680C, **ETS-2** pick up at 740C and accelerates the radiator fan to full speed. **ETS-3** is supposed to bring the engine idle with audiovisual alarm at 920C.

One water connection taken from this three way elbow through adopter to the TSC through a flexible pipe to cool intermediate casing, turbine casing and bearings. After cooling water returns to the inlet side of the pump.

Water temperature is controlled by controlling the movement of radiator fan. Cool water from the left side radiator passes through the lube oil cooler and cools lube oil. After lube oil cooler, it unites with right side radiator outlet, to be bank again to the suction side of the pump for recirculation.

Apart from Hot engine alarm, another safety device in the form of LWS (Low Water Switch) is also provided. It shut down the engine if the water level falls below 1 inch from the bottom of the expansion tank.

Vent lines are provided from after-cooler, lube oil cooler, radiators, TSC bubble collector, water return header (both side) bubble collector etc. to maintain uninterrupted circulation of cooling water by eliminating the hazard of air locks in the system.

Cooling water is subjected to laboratory test at regular intervals for quality control. Contamination, chloride contents and hardness etc are checked to reduce corrosion and scaling.

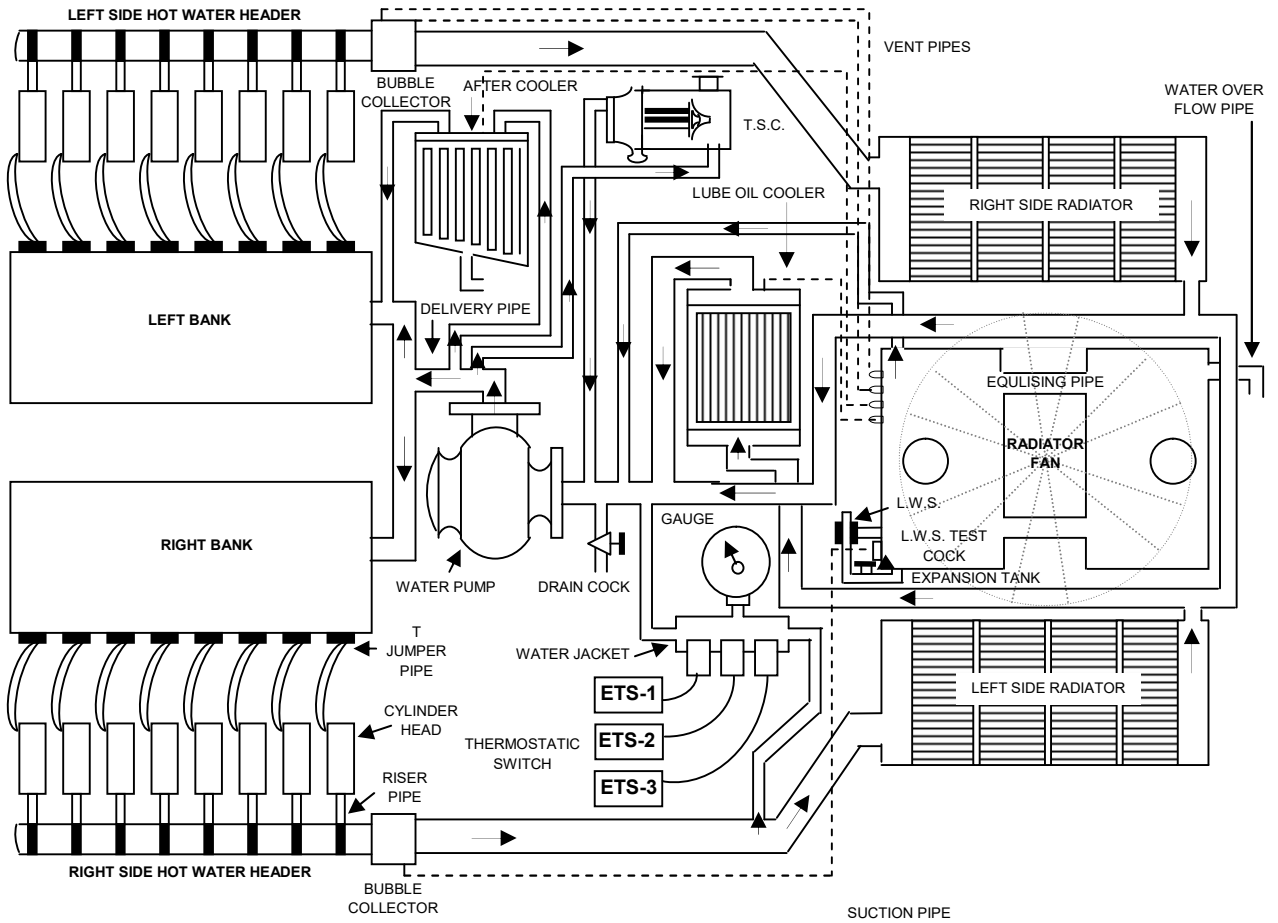

**WATER COOLING SYSTEM**

## **COOLING WATER SYSTEM (HHP)**

The capacity of expansion tank is 625 and total system is 1045 Lts. To read the water level gauge is provided in the right side of the Expansion tank. It has two readings full and low with respect to the status of the engine when running or dead. Normally the water level is to be below full level and at least low level according to the status of the engine. If less shed has to be informed. There are two numbers of gear driven centrifugal type water pumps available in this system and mounted on the engine block.

The lube oil cooler outlet forms the suction for both the pumps. When crank shaft starts to rotate, both water pumps start their working, draws water from the suction and delivered to water inlet manifold. The outlet of the right side water pump is sent to right water inlet manifold and left side water pump is sent to left water inlet manifold. From the water inlet manifold water enter to all the cylinder liner jackets through individual water jumper pipes and cools the cylinder liners.

After cooling the cylinder liners water enter the cylinder head through 12 circular passages and cool the combustion chamber of the cylinder head and then collected in the water outlet manifold. At the rear end of both water inlet manifolds, water is taken to after coolers to cool the booster air and then collected in the water outlet manifold. The outlet of both the pumps are connected together and taken to compressor to cool the compressor cylinders and the compressed air inside the inter cooler. The collected water in the water outlet manifold is taken to radiators, which are located in a hatch at the top of the long hood of the loco.

A bye-pass line is provided between the inlet and outlet lines of the radiators in order to reduce velocity in the radiator tubes. To cool the water in the radiator, two electrical motor operated radiator fans are used and controlled by the Locomotive control computer (LCC). The LCC maintain the water temperature between 79 and 850 C. Two Engine Temperature probes (ETP1 and ETP2) are provided to measure the water temperature.

Among the sensors, the higher value is taken as reference by the LCC. To simulate water temperature (up to 520 C), LCC increases the engine speed automatically. If water temperature increases above 960 C, maximum loco power will restrict to sixth notch limit but RPM is according to the throttle position. If water temperature increases above 1010 C, engine speed comes to idle.

To make up water level in the system, from the expansion tank, Equalising pipes are provided to the inlet of compressor and both water pumps. To protect the

engine from lack of cooling Low water Switch (LWS) and Low water pressure button (LWP in EPD) is provided in this system. LWS is available in WDP4 Locos in the left side of the expansion tank. It brings the engine to shutdown when water level is low. LWP is available in all locos in the EPD and connected with the system at the outlet of the left water pump through a three Lts way cock. It brings the engine to shutdown when water pressure is low in the system.

### **COOLING WATER SYSTEM**

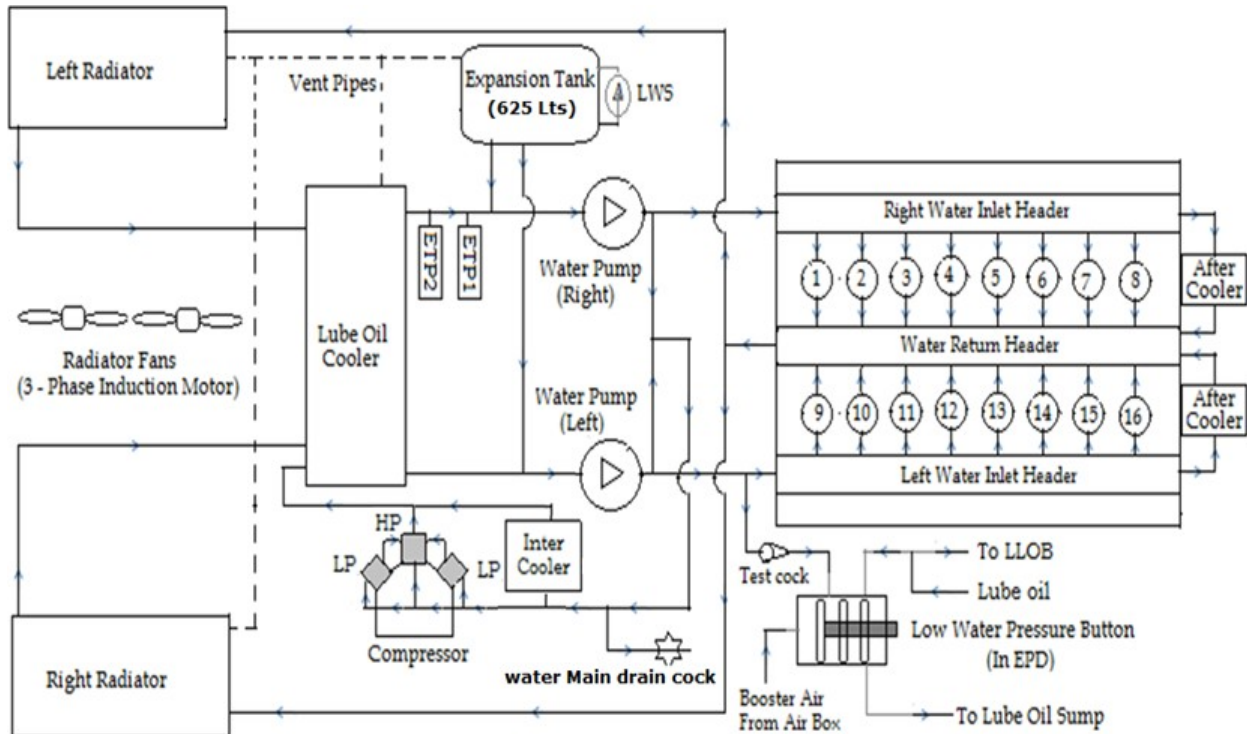

### **COOLING WATER SYSTEM – POINTS TO BE REMEMBER:**

1. Check the working of radiator fan physically even its status is “ON” in the display.
2. Operate the water filling cock lever handle in clockwise and also up to 90 degrees only. Otherwise it may damage the filling cock lever.
3. Before and after cranking water level to be ensured as the limit prescribed in the glow dot gauge. However in en-route while TOC if water level is below minimum in shutdown condition and after cranking if the level is above

minimum mark in running position, work the train duly give information to shed.

4. If water level reducing, check for external leakages and leakage in the tell tale pipe. If any leakage noticed, slack the spring loaded cap in the expansion tank to reduce the rate of leakage.
5. Check the engine lube oil and Compressor sump in case of water level running down.
6. If unable to reset low water button, ensure water level and LWP test cock is in open position and then press and hold LWP button for 15 seconds.
7. If engine shutdown with low water level in display, ensure water level. If level is low inform shed. If sufficient water level is available, short the wires provided in LWS and crank.

#### **ENGINE TEMPERATURE PROTECTION:**

The normal operating water temperature is 79 to 85o C and it is monitored by ETP1 and ETP2. Maximum of ETP1 or ETP2 is considered as engine water temperature.

| Temperature          | System Action                                                                                                                                                                                                                                                                                                                                                                                                                 |
|----------------------|-------------------------------------------------------------------------------------------------------------------------------------------------------------------------------------------------------------------------------------------------------------------------------------------------------------------------------------------------------------------------------------------------------------------------------|
| Water > 85° C        | One Fan will be made ON in slow speed.<br><br>Within 20 seconds if water temperature not dropped second fan is switched ON in slow speed.<br>Within next 20 seconds if water temperature not dropped First Fan will run at Fast and second one at slow speeds.<br>Within next 20 seconds if water temperature not dropped, both Fans will run at Fast speed.<br>Both Fans will stop when water temperature drops below 79° C. |
| Water > 96° C Notch. | Engine RPM remains high but Traction power limited to 6th<br><br>Display shows message “High water temperature – TH 6 Limit”                                                                                                                                                                                                                                                                                                  |
| Water - 101° C       | Along with message “High water temperature - TH 6                                                                                                                                                                                                                                                                                                                                                                             |

Limit" Bell Rings after 5 minutes Engine comes to Idle.

Lube oil above 122° C Engine come to shut down by Hot Oil Detector operation

It cannot be reset. Loco is to be failed for this trouble.