



# Supervisors Training Centre, South Central Railway



## ISM - 09 DIESEL THEORY (MDT – 05)

**September 2020**

## INDEX

S. NO	TOPIC	PAGE NUMBER
1	I.C engines, types, working classification	1.01 – 1.11
2	Supercharging principles, methods, air and vacuum brake systems	2.01 – 2.27
3	Fuel system, components, functions.	3.01 – 3.11
4	Lube oil system, components, working.	4.01 – 4.15
5	Cooling water system, components, working,	5.01 – 5.13
6	Shed layout	6.01 – 6.06
7	Under Truck	7.01 - 7.02
8	GM locos	8.01 – 8.43
9	Types of governors, overhauling procedure, testing methods	9.01 – 9.12
10	Safety Items	10.01 – 10.02
11	Load Box Testing	11.01 – 11.02

# 1. INTERNAL COMBUSTION ENGINES

## 1.1 INTRODUCTION

Internal combustion engines are seen every day in automobiles, trucks, and buses. The name internal combustion refers also to gas turbines except that the name is usually applied to reciprocating internal combustion (I.C.) engines like the ones found in everyday automobiles. There are basically two types of I.C. ignition engines, those which need a spark plug, and those that rely on compression of a fluid. Spark ignition engines take a mixture of fuel and air, compress it, and ignite it using a spark plug. Figure below shows a piston and some of its basic components. The name 'reciprocating' is given because of the motion that the crank mechanism goes through. The piston-cylinder engine is basically a crank-slider mechanism, where the slider is the piston in this case. The piston is moved up and down by the rotary motion of the two arms or links. The crankshaft rotates which makes the two links rotate. The piston is encapsulated within a combustion chamber. The bore is the diameter of the chamber. The valves on top represent induction and exhaust valves necessary for the intake of an air-fuel mixture and exhaust of chamber residuals. In a spark ignition engine a spark plug is required to transfer an electrical discharge to ignite the mixture. In compression ignition engines the mixture ignites at high temperatures and pressures. The lowest point where the piston reaches is called bottom dead centre. The highest point where the piston reaches is called top dead centre. The ratio of bottom dead centre to top dead centre is called the compression ratio. The compression ratio is very important in many aspects of both compression and spark ignition engines, by defining the efficiency of engines. Compression ignition engines take atmospheric air, compress it to high pressure and

temperature, at which time combustion occurs. These engines are high in power and fuel economy.

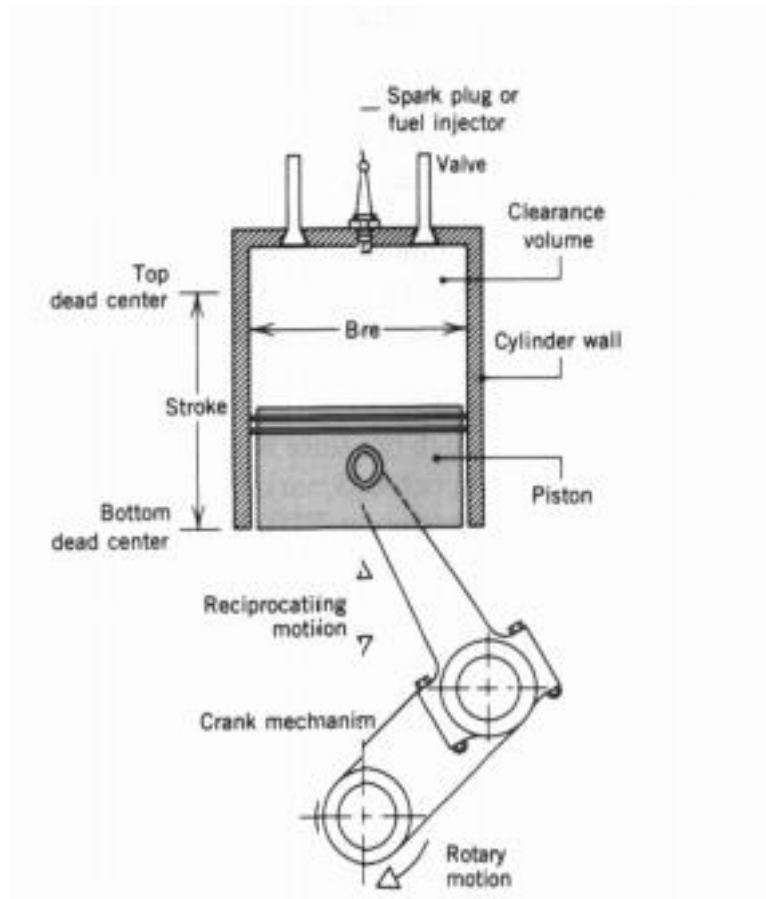

## PISTON

Engines are also divided into four stroke and two stroke engines. In four stroke engines the piston accomplishes four distinct strokes for every two revolutions of the crankshaft. In a two stroke engine there are two distinct strokes in one revolution. Figure below shows a p-v diagram for the actual process of a four stroke internal combustion (IC) engine. When the piston starts at bottom dead centre (BDC) the intake valve opens. A mixture of fuel and water then is compressed to top dead centre (TDC), where the spark plug is used to ignite the mixture. This is known as the compression stroke. After hitting TDC the air and fuel mixture have ignited and

combustion occurs. The expansion stroke, or the power stroke, supplies the force necessary to drive the crankshaft. After the power stroke the piston then moves to BDC where the exhaust valve opens. The exhaust stroke is where the exhaust residuals leave the combustion chamber. In order for the exhaust residuals to leave the combustion chamber the pressure needs to be greater than atmospheric. Then the piston proceeds to TDC where the exhaust valve closes. The next stroke is the intake stroke. During the intake stroke the intake valve opens which permits the air and fuel mixture to enter the combustion chamber and repeat the same process.

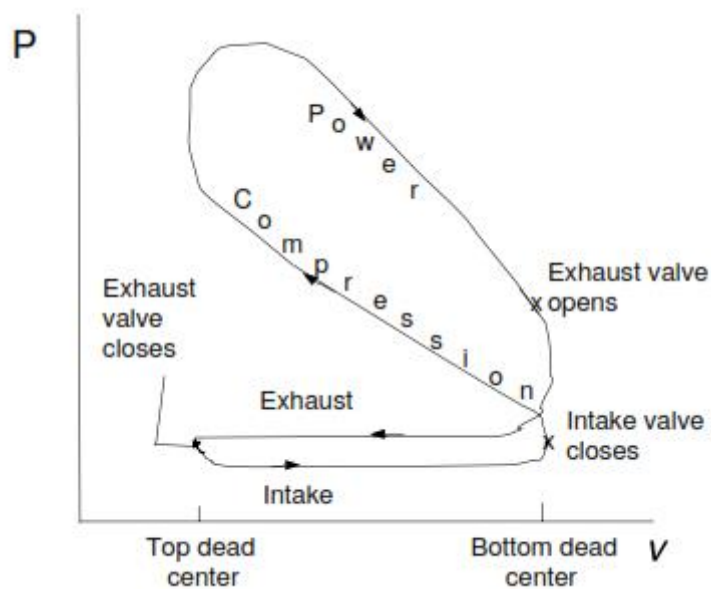

### ACTUAL CYCLE

## SPARK IGNITION ENGINES

Internal combustion engines are divided into spark ignition engines and compression ignition engines. Almost all automobiles today use spark ignition engines while trailers and some big trucks use compression ignition engines. The main difference between the two is the way in which the air to fuel mixture is ignited,

and the design of the chamber which leads to certain power and efficiency characteristics. Spark ignition engines use an air to fuel mixture that is compressed at high pressures. At this high pressure the mixture has to be near stoichiometric to be chemically inert and able to ignite. Stoichiometric means that there is a one to one ratio between the air and fuel mixture. So the mixture in order to ignite needs not to be either with too much fuel or too much air but rather have an overall even amount. There are several components to the spark ignition engine. Chamber design, mixture and the injection system are some of the most important aspects of the spark ignition engine. The importance of the chamber design will be discussed.

The four basic designs for combustion chambers are as follow:

1. The distance travelled by the flame front should be minimized
2. The exhaust valve and spark plug should be close together
3. There should be sufficient turbulence
4. The end gas should be in a cool part of the combustion chamber.

The first design requires that the distance between the end gas and the sparkplug be close in order for combustion to progress rapidly. If combustion is sped up then, (i) the engine speed is increased and therefore power output is higher, and (ii) the chain reactions that lead to knock are reduced. From the second design criteria the exhaust valve, since it is very hot, should be as far from the end gas in order to prevent knock or pre-ignition. The third design criteria suggest that there should be enough turbulence in order to promote rapid combustion", through mixing. Too much turbulence, however, will lead to excessive heat transfer from the chamber and too rapid combustion which causes noise. Turbulence in combustion chambers is generated by squish areas or shrouded inlet valves. The fourth design

requires that the end gas be in a cool part of the combustion chamber. The cool part of the combustion chamber forms between the cylinder head and piston.

The process by which the air to fuel mixture is prepared and put in the combustion chamber is through carburettors and fuel injectors. Spark plugs are part of all spark ignition engines. In order to start one of these engines a spark has to ignite a mixture into a flame. The way in which this spark is first initiated is through the car battery and a circuit directly leading to the spark plug. The battery supplies the electric current to initiate a spark in the spark plug. The Spark then ignites the air and fuel mixture. The type of fuel injectors used divide into multi-point and single-point injection. Carburettors divide into fixed and variable jet carburettors. The air and fuel mixture is analyzed as either a lean or rich mixture depending on the content of fuel. A stoichiometric mixture is one in which there is a perfect ratio of air and fuel molecules. A lean mixture would be deficient in fuel where a rich one would be saturated with fuel. To achieve economic status and yet receive the maximum power the engine would have to use a lean mixture and a rich one at full throttle. When the throttle is fully opened and lean mixtures used the power output is economical because of the weak fuel. When the throttle is opened the combustion chamber needs the air to fuel mixture. Since a stream of air is generated extra fuel is needed to compensate for the insufficient flow of fuel. In order to obtain maximum power a rich mixture is needed. For good fuel economy all the fuel should be burnt and the quench area where the flame is extinguished should be minimized.

## **COMPRESSION IGNITION ENGINES**

Compression ignition engines differ from spark ignition engines in a variety of ways but the most obvious one being the way in which the air and fuel

mixture is ignited. As stated above a spark plug is used to create a spark in the combustion chamber which ignites the mixture. In a compression ignition engine there is no spark to create the flame but rather high temperatures and pressures in the combustion chamber cause a flame to initiate at different sites of the combustion chamber. Combustion increases with increasing pressure and temperature. Compression ignition engines are divided into direct and indirect ignition engines. Diesel engines require fuel injection systems to inject fuel into the combustion chamber. Fuel injection systems are either linear or rotary. Rotary fuel injectors are used in indirect ignition engines because of low pressures.

Direct injection engines use pressures of up to 1000 bars to inject fuel into the combustion chamber. High pressure is needed because the heat addition process takes place at a compressed state, so in order for the fuel to inject well the pressure has to be greater than the one that has been accumulated through compression. There are several engineered direct injection combustion chambers. This goes to show that the actual design of compression ignition engines is not as critical as the design considered for spark ignition engines. Swirl is the most important air motion in the Diesel engine. The importance of swirl is that it mixes the air and fuel so that combustion can increase. The direction of swirl is at a downward angle so that proper mixing can take place. The compression ratio for direct ignition engines is usually between 12:1 and 16:1.

Indirect ignition engines have a pre-combustion chamber where the air to fuel mixture is first stored. The purpose of the separate chamber is to speed up the combustion process in order to increase the engine output by increasing the engine speed. The two basic combustion systems are the swirl and pre-combustion chambers. Pre-combustion chambers depend on turbulence to increase the



combustion speed and swirl chambers depend on the fluid motion to raise combustion speed. In divided chambers the pressure required is not as high as the pressure required for direct ignition engines. The pressure required for both type of divided chambers is only about 300bars.

With all Diesel engines there is some type of aid to help combustion. Electrical components aid in the initiation of the combustion process by using an electrical source, such as a car battery, to heat themselves and transfer the energy to the mixture for combustion. Cold starting a Diesel engine is very difficult without the use of these tabs that conduct an electric current. When electrical elements heat up and the air to fuel mixture comes in close contact with the tab then combustion occurs. The Diesel engine has high thermal efficiencies, and therefore low fuel consumption. The disadvantage of Diesel engines is their low power output, relative to their weight, as compared with spark ignition engines.

#### **WORKING OF 4 STROKE CYCLE DIESEL ENGINE:**

1. **SUCTION STROKE:** In this stroke the piston is moving from TDC to BDC. The inlet valve is kept open and air enters into the engine cylinder.
2. **COMPRESSION STROKE:** In this stroke both valves are kept closed. The trapped air in the cylinder getting compressed due to piston moving from BDC to TDC. Due to this the pressure and temperature of air are increased. As the piston reaches to TDC, the fuel is injected into the engine cylinder.
3. **POWER STROKE:** The burning of air / fuel mixture develops huge hot gases. This makes the piston to move from TDC to BDC and in turn crank shaft rotates on its own.
4. **EXHAUST STROKE:** In this stroke piston moves from BDC to TDC. The exhaust valve kept in open. The waste gases start escaping from cylinder.

After completion of exhaust stroke, again the suction stroke takes place and cycle will repeat and engine kept in working. The engine in WDM2, YDM4/4A, WDM3A, WDP1 and WDG3A locos work in this principle.

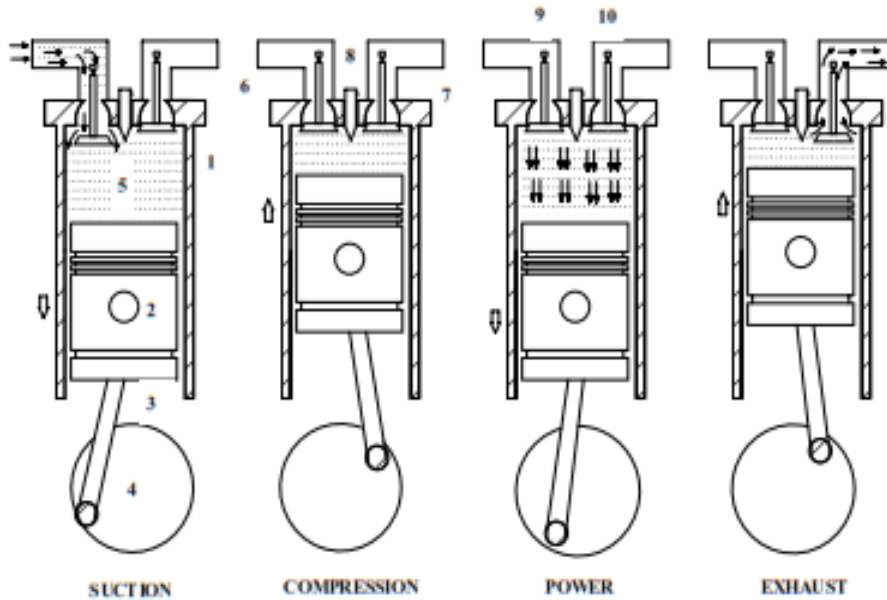

FOURSTROKE CYCLE ENGINE WORKING PRINCIPLE

### WORKING OF 2-STROKE CYCLE DIESEL ENGINE:

In this type of engine, two or more operations are being overlapped. Inlet valves are replaced by ports (a cut on cylinder liner). The opening and closing of port is regulated by piston movement itself.

- 1. INTAKE:** Since the piston is away from the ports (at BDC) the outside air starts rushing into engine cylinder. This process continues till the piston obstructing the ports.

2. **COMPRESSION:** Once the piston obstructed ports further air entry is stopped and trapped air is getting compressed till the piston reaches to TDC.
3. **POWER:** Once the piston reaches TDC, fuel is injected into compressed air and oil is burnt. Due to this immediately piston starts moving down and in turn the crank shaft rotates on its own.
4. **EXHAUST & SCAVENGING:** As the piston starts moving from TDC to BDC at one time the piston is again away from ports. Due to this the outside air starts rushing in. Mean time the exhaust valve also kept open to vent out waste gases. This process of simultaneous entry of air venting of gases is called "SCAVENGING".

After reaching of piston to BDC, it starts moving in up direction. The processor air entry continues up to piston obstructing ports. And again during same movement the compression of air also happens. In this each time piton moves from TDC to BDC with the POWER

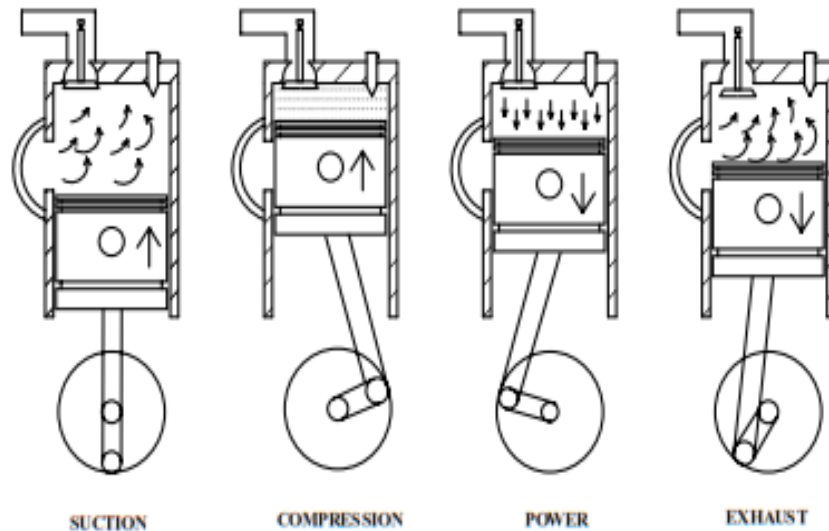

**TWO STROKE CYCLE ENGINE WORKING PRINCIPLE**

**CLASSIFICATION OF DIESEL ENGINES IN VARIOUS LOCOMOTIVES:**

**In WDM2, 2A, 2B, WDM3A, WDG3A, and WDP2 locos:**

16-cylinder, V-type Inline, 4-stroke cycle, solid fuel injection system with separate FIP and Injector, forced feed lubrication, water cooled, turbocharged, variable speed, diesel engine.

**In WDP1 locomotives:**

12-cylinder, V-type Inline, 4-stroke cycle, solid fuel injection system with separate FIP and Injector, forced feed lubrication, water cooled, turbocharged, variable speed, diesel engine.

**In WDG4 and WDP4 locos:**

16-cylinder, V-type Inline, 2-stroke cycle, solid fuel injection system with unit injectors, forced feed lubrication, water cooled, turbo charged, variable speed, diesel engine.

**In YDM4/4A, WDS6 locos:**

6-cylinder, Vertical Inline, 4-stroke cycle, solid fuel injection system with separate FIP and Injector, forced feed lubrication, water cooled, turbocharged, variable speed, diesel engine

## 2.CHARGE AIR SYSTEM

### 3.1. REQUIREMENT OF AIR SUPER CHARGING SYSTEM

Diesel engine Uses chemical energy to generate Heat energy. This heat energy will be later converted into Mechanical energy. To produce the heat energy, fuel is burned inside the combustion chamber. For efficient burning more oxygen is required. For supplying more fuel, SUPER CHARGING is required. In this process air is introduced into the engine cylinder at a density more than ambient. This will produce more power than a naturally aspirated engine for the same bore and stroke dimension. Super charging causes better scavenging also.

#### ADVANTAGES OF SUPER CHARGING

- Better cooling of components.
- Saves them from failure due to thermal stresses.
- Enhances the service life.
- Better fuel efficiency.
- Power to weight ratio is much more.

#### METHODS OF SUPERCHARGING

- **Separately driven air compressor:**

This type of supercharging used on four wheel drive military vehicles. This method provides high SFC.

- **Blowers driven by exhaust gas.**

Here turbocharger uses the energy of waste Exhaust gas. This is a very efficient & economical method. Blowers run by the exhaust gas driven turbine.

#### WORKING:

At the engine free end, a Turbo super charger is mounted on the top of after cooler housing -cum- TSC support. The exhaust manifold pipe of engine is directly connected to TSC. All the exhaust gases collected from each cylinder exhaust elbow, will flow in this pipe and pass in gas inlet casing. Through fixed nozzle ring

the gases strike turbine rotor with blades inside the turbine casing. This makes the rotor to revolve, and then the gases will escape through exhaust chimney provided on turbine casing. The rotation of turbine rotor will cause blower also to rotate which is mounted on other end of rotor shaft. The shaft is supported with two bearings inside the intermediate casing. The blower is covered in blower casing and its rotation will suck the atmospheric air through car body filters (CBF) and engine air intake filters (Air maze oil bath filters or cyclonic air filters). Here the air is cleaned either by oil bath in case of oil bath filters or inertia in case of cyclonic air filters. Continuous rotation of blower will compress the atmospheric air. Due to the compression the temperature of air also will increase and makes air density to reduce. To increase density of this turbo charged air by cooling it, it is discharged into the after cooler unit. Here the air is cooled due to indirect contact with coolant water which is passing in after cooler core. The cooled compressed air is called BOOSTER AIR is now further discharged into air inlet manifold or 'V' channel which is located inside the engine block. From here there are 16 air inlet elbows which are connected to each cylinder head towards inlet valves. As per the cyclic operation, the inlet valves will open and booster air will rush into engine cylinder. After completion of compression and power strokes in the engine cylinder(s) the exhaust gases will be sent out and collected in exhaust manifold. From exhaust manifold again gases will enter TSC and revolves turbine rotor and finds path into atmosphere. On the other side, the blower will suck in more and more air due to increased speed and develops more Booster Air for the engine. This Booster air will develop from 4th/ 5th notch RPM on load (train working) only. At 8th notch full load the developed hot gases will rotate turbine rotor at 18,000 to 21,000 RPM depends upon the TSC design and develops BAP up to 1.6 to 2.4 Kg/cm<sup>2</sup> according TSC. To indicate the BAP there is a gauge pipe connection on V channel and gauge is provided in Drivers cab. In case WW governor locos, a branch connection is taken to WW governor also to operate over riding function in governor.

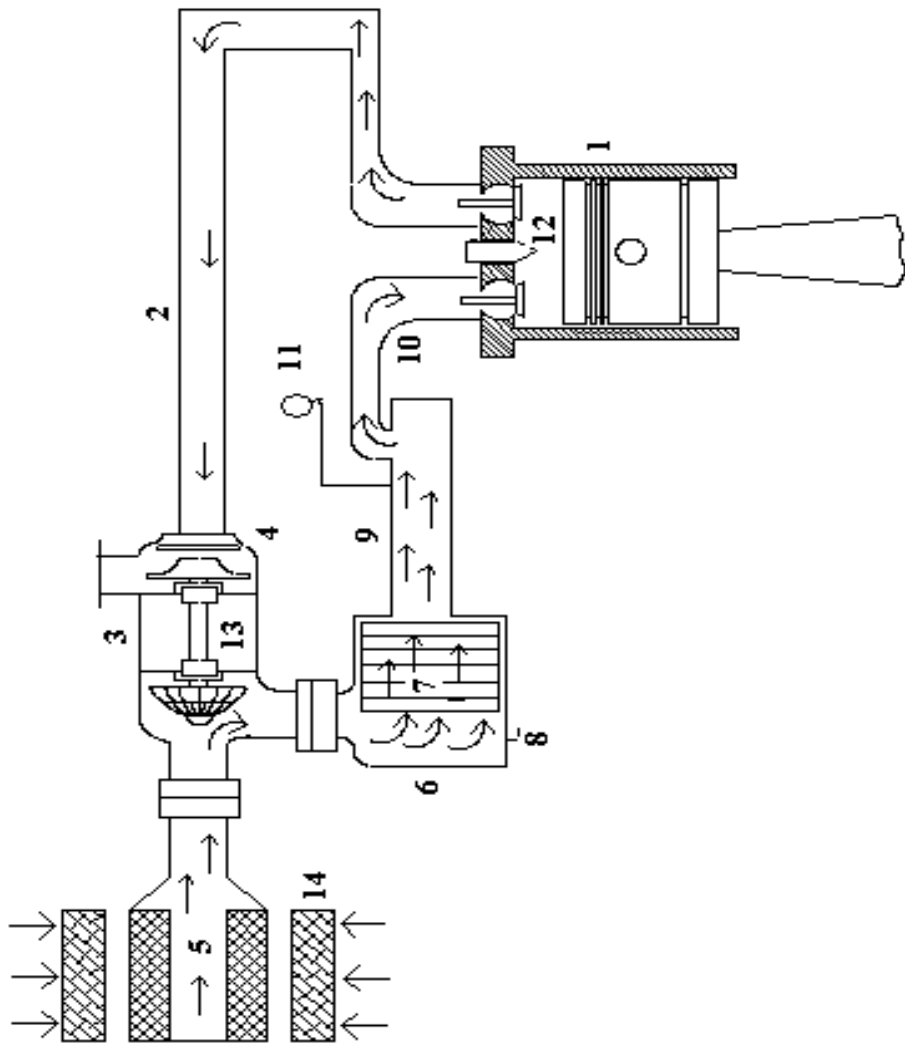

**CHARGED AIR SYSTEM**



## **BRIEF DESCRIPTION OF THE IRAB – 1 BRAKE SYSTEM**

### **INTRODUCTION**

IRAB – 1 brake system is a complete air brake version, in which only compressor unit is used instead of Expresser for creating air pressure in the brake system and all the brake valves are panel mounted.

### **SALIENT FEATURES OF IRAB – 1 SYSTEM**

1. Locomotives Brakes can be applied and released through independent brake valve SA9, independently.
2. Formation brakes can be applied & released through Automatic brake valve A9.
3. Locomotive brakes are applied automatically when formation brakes are applied.
4. It is suitable for MU operation also, with which the brakes of trailing units are controlled from leading unit.
5. Brakes in the rear loco are synchronized with lead loco brakes.
6. Emergency brake application is available to have minimum possible braking distance, from any control stand and any loco.
7. Safety devices are incorporated to bring the engine to idle in case of emergency brake application and train parting.
8. In case of train parting between the locos, both the locos will have automatic brake application.
9. Automatic brake and Dynamic brakes are inter locked. So that, Auto Brake will be released automatically when the DB is applied.
10. The system can work either with single pipe / dual pipe

## AIR BRAKE SYSTEM VALVES

SL. NO	DESCRIPTION	PURPOSE
1.	A9. Automatic Valve	Brake application for Loco as well as formations.
2.	SA 9 Independent Brake Valve	Brake Application for Loco alone
3.	MU – 2B	M.U. Operation, used as gate valve
4.	F 1 – Selector	M.U. Operation, used as gate valve
5.	C <sub>2</sub> . W. or Additional C <sub>2</sub> . Valve	Feeding B. P. Pressure to the formation
6.	24 A. Double Check Valve	This will allow only one operation at a time.
7.	C <sub>3</sub> . W. Distributor Valve	Proportionate Brake valve application during A9. application.
8.	C <sub>2</sub> . Relay Valve	For Locomotive Brake.
9.	Pressure Switch	Loco will be brought to idle during A9 emergency application.
10.	D1. Emergency Valve	For Emergency brake application.
11.	D1. Pilot air valve	During Dynamic brake Loco brake will be released.
12.	Pressure Limiting Valve	Pilot air to C <sub>2</sub> .Relay valve for synchronized brake application is Limited to 2.5 kg / Cm <sup>2</sup>

13.	M. R. Safety Valve	When M. R. Pressure goes beyond 10.5 kg / Cm <sup>2</sup> This valve will operate and release excess pressure from MR.
14.	Duplex Check Valve Set at 6 kg / Cm <sup>2</sup>	This valve will connect MR1 with feed valve when MR pressure exceeds 6 kg / Cm <sup>2</sup>
15.	D 24 – Feed Valve	For Feed pipe Pr: 6 kg / Cm <sup>2</sup> .

**IMPORTANT VALVES PROVIDED IN IRAB – 1 SYSTEM.**

**SA 9 INDEPENDENT BRAKE VALVE:**

It is a variable pressure-reducing valve, sends pilot air to C2 relay valve to charge brake cylinder for application and release of loco brake independently. The outlet pressure can be varied from 0 to max (3.0 Kg / Cm<sup>2</sup>) by moving its handle. Its handle has three distinct positions.

1. Application
2. Release
3. Quick release – In IRAB, this position is not active.

The output pressure is zero at release position and the pressure is max (3.0 Kg / Cm<sup>2</sup>) at application position. The handle can be placed at any position between release and application to have desired out let pressure(i.e., brake cylinder pressure)

**SA9 INDEPENDENT BRAKE**

**A9 – AUTOMATIC BRAKE VALVE**

The valve is also a variable pressure-reducing valve. Its duty is to send pilot air for charging/ exhausting B.P. pressure through C2W relay valve for releasing and

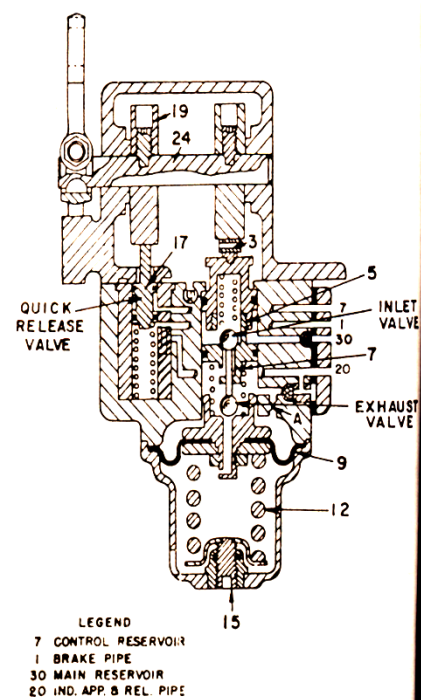

application of loco and formation brake. In release condition it charges BP up to 5.0 Kg/cm<sup>2</sup>(max). The BP pressure can be varied by moving its handle.

The handle has 5 distinct positions.

1. Release (BP= 5 Kg/cm<sup>2</sup>)
2. Minimum release (BP = 4.5 to 4.3 Kg/cm<sup>2</sup>, BC = 0.5 to 0.7 Kg/cm<sup>2</sup>)
3. Full service (BP = 3.2 to 3 Kg/cm<sup>2</sup>, BC = 2.5 Kg/cm<sup>2</sup>)
4. Over reduction (BP = 2.5 Kg/cm<sup>2</sup>, BC = 2.5 Kg/cm<sup>2</sup>)
5. Emergency (BP = 0 Kg/cm<sup>2</sup>, BC = 2.5 Kg/cm<sup>2</sup>)

The outlet pressure (Brake pipe) is maximum i.e. 5Kg/ cm<sup>2</sup> when the handle is at release position. The pressure will reduce when the handle is moved to application zone. The BP pressure will correspond to the position of the handle between Min and Full service and will be zero at emergency.

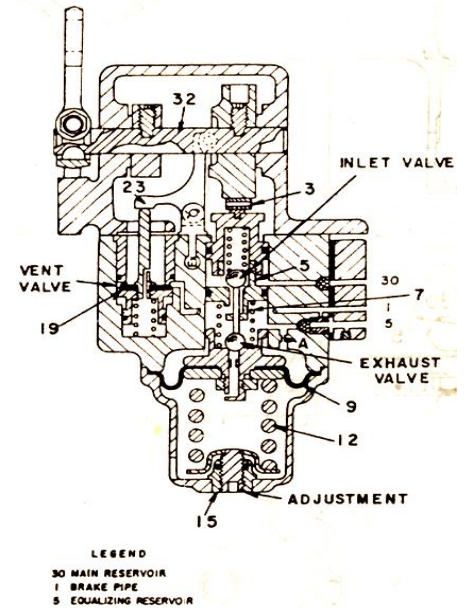

A9-AUTOMATIC  
BRAKE VALVE

### C<sub>2</sub> RELAY VALVE

It is a high capacity relay air valve.

It gets pilot air from SA9/ A9 and supply MR air to the brake cylinders at a pressure equal to the pilot air pressure at a higher rate. Thereby it applies and releases the brake.

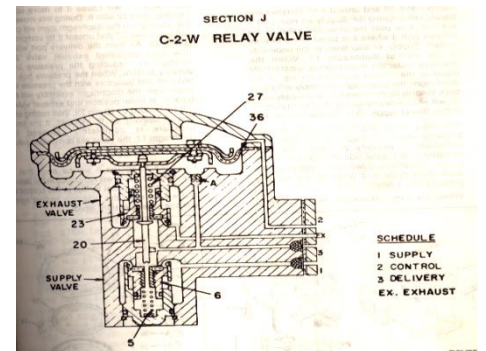

**C<sub>2</sub> W – Relay VALVE:** It is similar to C<sub>2</sub> relay valve with some additional features. It is connected to the BP charging/ exhausting system. It gets pilot air from A9 brake valve and it charges/ exhausts BP



accordingly. As compared to C2 relay valve it is having an additional diaphragm and pusher pin above the main diaphragm. If air is charged above this diaphragm, it pushes the main diaphragm and increases the pressure setting for the main diaphragm with the same pilot air from A9. This increment is limited by another arrangement so that the outlet pressure cannot build up more than 5.4 Kg/Cm<sup>2</sup>. This function is called as overcharging function. It helps to release the brake binding in any of the variable from the locomotive cab.

### C<sub>3</sub>W- Distributor VALVE

It is an automatic brake application valve. It is used for conjunction brake application in the locomotive in proportion to the formation brake. It is having two air chambers. Control reservoir (CR) and Brake Pipe (BP). If  $BP \geq CR$ , Brake is released, i.e.  $BC = 0$  and when  $BP < CR$  brakes are applied. The difference between CR and BP pressure will decide the amount of BC pressure. As BP is common in the train and locomotive hence according to the BP drop page the brake application and release will be synchronized in the formation and locomotive.

### MU = 2B: -

It is manually operated change over valve. It makes the system to be controlled from the same unit or the leading unit. It also isolates the drivers control for application and release of brakes in trailing loco.



The knob of this valve has 2 positions.

1. Lead
2. Trail or Dead.

There are many ports in this valve and their connections are changed as under:

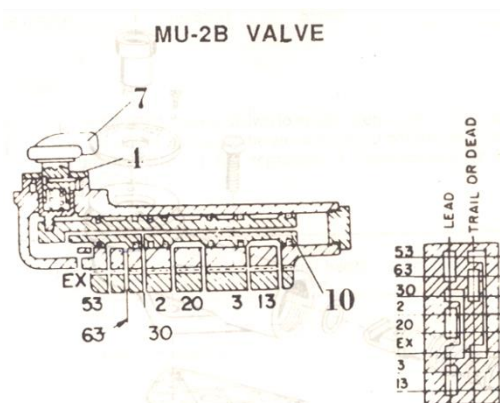

Lead	2,20	3,13	63,53	60 – Exhaust
Trail or Dead	--	--	63 – 30	53 – Exhaust

**F1 – SELECTOR: -**

This valve is also a change over valve.

It has 2 positions:

1. Lead
2. Trail or dead.

The position is changed automatically according to the position of MU2B valve. Port 30 from MU2B is piped to this valve. When there is no pressure in this port F1 selector will assume, lead position. If air pressure is supplied from the port, F1 selector will assume Trail or dead position.



This valve also has many ports and the connections are given below.

Lead	4-16	30 14	-
Trail or dead	14-16- 20		

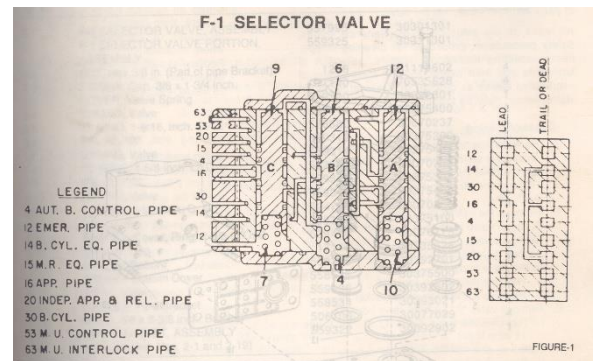

In co-ordination with MU2B, this valve makes the system to operate as a lead unit or trail unit.

**D1 – EMERGENCY VALVE:-**

This valve is a flap valve with suitable lever. It is connected directly with the Brake pipe. If this valve is opened, BP drops to Zero at the faster rate and thus brake application is made very fast with maximum braking effort and minimum braking distance

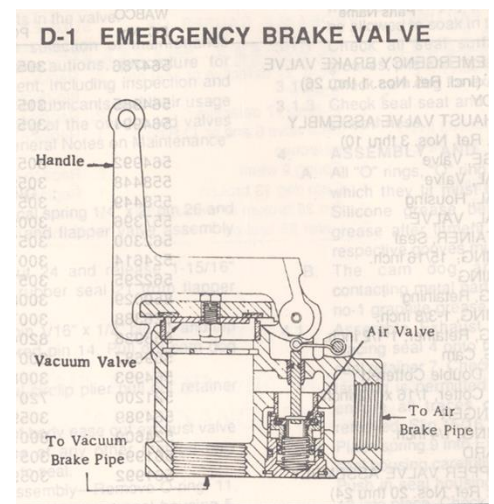

1. In case of emergency, when the assistant driver notices any obstruction / defect in track which the driver could not notice, the assistant driver can operate independently.
2. When the normal application of brakes is not possible or not affected, the driver or assistant driver can use this valve to stop the train.



### **D1. PILOT AIR VALVE CUM BRAKE ISOLATING VALVE**

It is an electrically operated solenoid valve. Whenever Dynamic Brake is applied it disconnects the supply from C3W Distributor valve and connects it to Exhaust. Thus it nullifies the loco brake application through A9 when dynamic brake is applied.

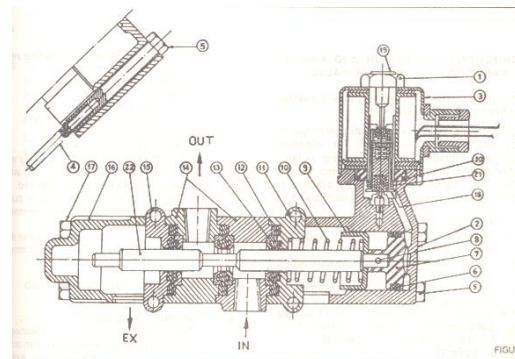

### **D1. PILOT AIR VALVE CUM BRAKE ISOLATING VALVE**

#### **PRESSURE LIMITING VALVE :-**

This will control the Output pressure of C<sub>3</sub>W valve to the desired level. This valve is fitted at the outlet of C<sub>3</sub>W valve to limit the Brake Cylinder pressure to 2.5Kg/Cm<sup>2</sup>.



#### **PRESSURE LIMITING VALVE**

### **24-A DOUBLE CHECK VALVE :**

This connects two inlet passages in a common outlet. At a time it connects only one of the two inlet passages with the outlet by isolating the other.



24A-

### **DOUBLE CHECK VALVE**

### **AIR FLOW MEASURING VALVE**

This valve indicates charging rate of BP / the leakage of BP pipe through an indicator, which is calibrated in term of No of wagons. Indicator is located at driver's control stand. MR air is connected to C2 W relay valve through Air Flow Measuring valve.

#### **Construction:**

MR air is connected to C2 W relay valve through inlet and outlet passages of AFM valve. Disc valve controls inlet and outlet passage of AFM valve. Disc valve has two small ports, one connects MR air to the top chamber of Disc Valve and other connects MR from top chamber of disc valve to Additional C2 Relay valve. Top chamber of Disc valve is the bottom of main diaphragm. Disc valve is pressed down through a follower & spring on its seat. Choke B is provided to connect MR air to top chamber of main diaphragm. Choke C is provided to supply 'main diaphragm top chamber air' to indicator, when diaphragm moves down word. Choke D is provided regulate air supplied through choke C towards indicator.

#### **Working:**

When the brake pipe is fully charged with air and the air brake is in the release condition, the air flowing from the main air supply through the Airflow measuring valve and to the brake pipe is that necessary to overcome leakage. In this condition the disc valve is closed as shown in diagram and air from the main supply passes through choke A in to the top chamber of disc valve and out to the Additional C2-Relay valve. It also passes in to the chamber under the diaphragm via the space



around the follower. At the same time, air from the main supply passes through a filter and choke B in to the chamber above the diaphragm.

So long as the pressures above and below the diaphragm are equal, the diaphragm floats against the choke C. As brake pipe leakage occurs, the pressure at the outlet port and under the diaphragm falls and the diaphragm is moved down away from the choke C and permits air entering the chamber above the diaphragm via choke B, to flow through choke C to an indicator and through choke D to atmosphere.

Choke D is smaller than choke C and an intermediate pressure builds up in the passage between them and registers on the indicator. This intermediate pressure is related to the flow of air through choke C that is controlled by the diaphragm reacting to the pressure under it. As the pressure under the diaphragm depend upon the fall of pressure at the outlet port relative to the main supply pressure, being guided by the flow rate towards BP to make good the leakages during run. It also determines the flow of air through choke A. The indicator therefore provides a visual indication of the amount of air flowing to the brake pipe.

During initial charging or release of brakes, when a large quantity of air passed to the brake pipe, the pressure at the out let port and in spring chamber reduces sufficiently. It allows the supply pressure to lift the disc valve off its seat and permit unrestricted flow of air to the brake pipe through C2 W-Relay valve. Under these conditions a high intermediate pressure builds up in the passages between chokes C and D, and the indicator indicates a high rate of airflow.

Choke D is variable to facilitate calibration and may be altered by means of an adjusting screw, turning the screw clockwise reduces the aperture and turning it anticlockwise enlarges it.

### **Calibration**

The Airflow measuring valve includes a calibration choke enclosed by a vent plug. This feature is provided to facilitate the calibration of the equipment on the vehicle. There is a test stand, where the needle valve setting is calibrated on 130 psi charging line. Where AFM valve indicator gauge reads 70 psi/ 100 wagons reading.

### **AIR FLOW INDICATOR**

It is an air pressure gauge with two pointers. Red pointer is called reference pointer, which is attached to a knurled knob and protrudes through the dial glass, so that it

can be set manually in any desired position, where as the other pointer (White) moves on the scale depending up on the air flow. The indicator is connected to the measuring valve through R-6 relay valve. The scale on the gauge is calibrated in terms of number of wagons. The 60 marks correspond to the maximum rate of airflow that can be accepted to overcome leakage on a 60 wagon train and so on

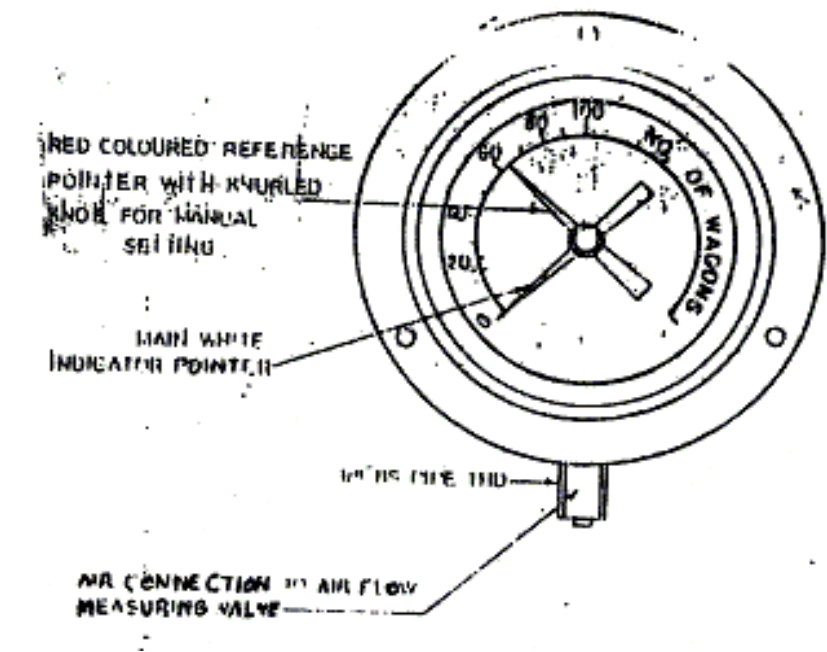
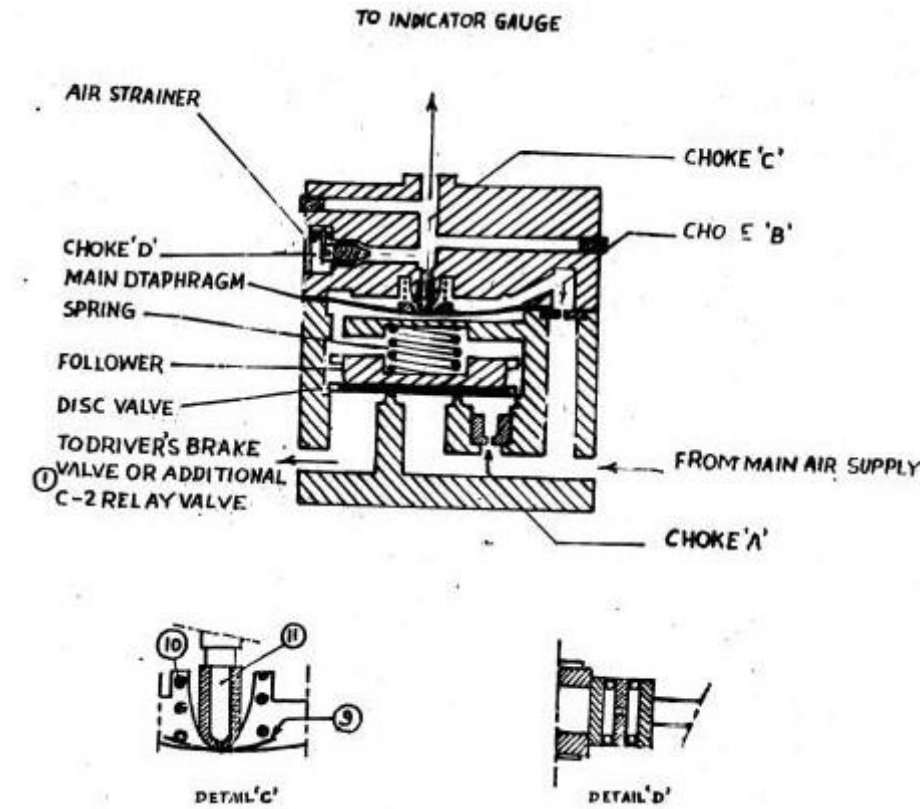

AIR FLOW INDICATOR

## **INDEPENDENT BRAKE-APPLICATION AND RELEASE.**

Independent brake application and release is controlled through SA9 Brake handle. When SA9 handle is kept in released position, Brakes are in released condition. When SA9 handle is moved to application zone, it supplies pilot air to C2 relay valve through Port No: 20 to Port No: 2 of MU2B. In lead loco or single unit loco MU2B is kept in lead position. In this, Port No 2 & 20 are interconnected and air from MU2B will come out through port 20. This air acts as Pilot air for C<sub>2</sub> relay valve, entering at Port No 2 (Pilot port) through a double check valve. This pressure acts at the top of main diaphragm of C<sub>2</sub> relay valve. (In trailing loco the MU2B is kept in trail position, port No 2 & 20 are isolated hence brake cannot be applied from the trailing loco).

C<sub>2</sub> relay valve in turn will supply air to the Brake Cylinder through port 3 at a pressure equal to pressure at port 2.

There are two Brake cylinders in locos. The outlet air from C<sub>2</sub> relay valve goes to the brake cylinders and applies the brakes.

One branch from C<sub>2</sub> relay outlet is connected to F1 selector port 30. Since MU2B is in lead, F1 selector also will be in lead and hence the air at port 30 comes out through port 14 and charges the brake cylinder-equalizing pipe. Normally the COCs at both the ends of BC equalizing pipe are in closed condition. This pipe will be coupled to the trailing loco in MU operation to apply the brakes in trail loco.

If the SA9 handle is moved to release position, the pilot air supplied to C<sub>2</sub> relay port 2 will be withdrawn and exhausted through SA9 exhaust port. In turn, C<sub>2</sub> relay valve will withdraw the brake cylinder pressure and exhaust it through exhaust port, till the Brake cylinder pressure is equal to pilot air pressure at port 2. (In this case 0). The pilot air for Brake cylinder pressure will be proportionate to the position of SA9 handle during application and release. A gauge pipe is connected after the front truck Brake cylinder COC to indicate the BC pressure to the driver's control stand.

## **AUTOMATIC BRAKE APPLICATION AND RELEASE.**

### **BP CHARGING:**

The charging and exhausting of BP is done through A9 Brake handle for application and release of formation brake in conjunction with Loco Brake. When the A9 handle is kept in release position, it supplies pilot air at 5 Kg/Cm<sup>2</sup> to the port 2 of C<sub>2</sub>W relay

air valve through MU2B port 3 and 13. A volume reservoir is also connected at this line to dampen fluctuation of pressure. C<sub>2</sub>W valve thus charges the BP equal to the pilot pressure. At the outlet of C<sub>2</sub>W valve, a ¾" COC is fitted which should be open in single unit / lead unit and closed in trailing unit.

At the inlet to C<sub>2</sub>W relay valve, an airflow-measuring valve is fitted which is connected to an Air Flow Indicator Gauge situated at Driver's Cab. The indicator indicates the rate of MR airflow through C<sub>2</sub>W relay valve i.e. rate of charging of BP. This arrangement is used to find the condition of brake pipe. If the leakage in B Pipe is high, the indication will show a higher value. If there is no leakage the indicator show zero.

### **MONITORING OF BP CHARGING:**

While starting a train after coupling and charging the Brake pipe, the driver should check the indicator reading. It should be less than the number of vehicles in that train. (The graduations are in 'No of wagons') and turn Red needle and align with the white needle. While working, if BP starts leaking, the white needle will overshoot the red needle. This is the indication of a problem / leakage in Brake pipe. On getting this indication, the driver should stop, investigate the reason for BP leakage and rectify.

When the A9 valve handle is moved to application zone i.e. to min. reduction, or more, A9 valve reduces the pilot air to C<sub>2</sub>W and hence C<sub>2</sub>W also reduces the brake pipe pressure (BP charging rate drops to zero).

When A9 handle is kept in Emergency, the Brake pipe drop to zero immediately causing emergency brake application in formation (BP charging rate drops to zero).

During release the rate of charging of BP is very high and the white needle deflection of Airflow indicator shoots up and then stabilizes, which should not be misunderstood as defect in Brake pipe

## BRAKE PIPE CHARGING (IRAB 1)

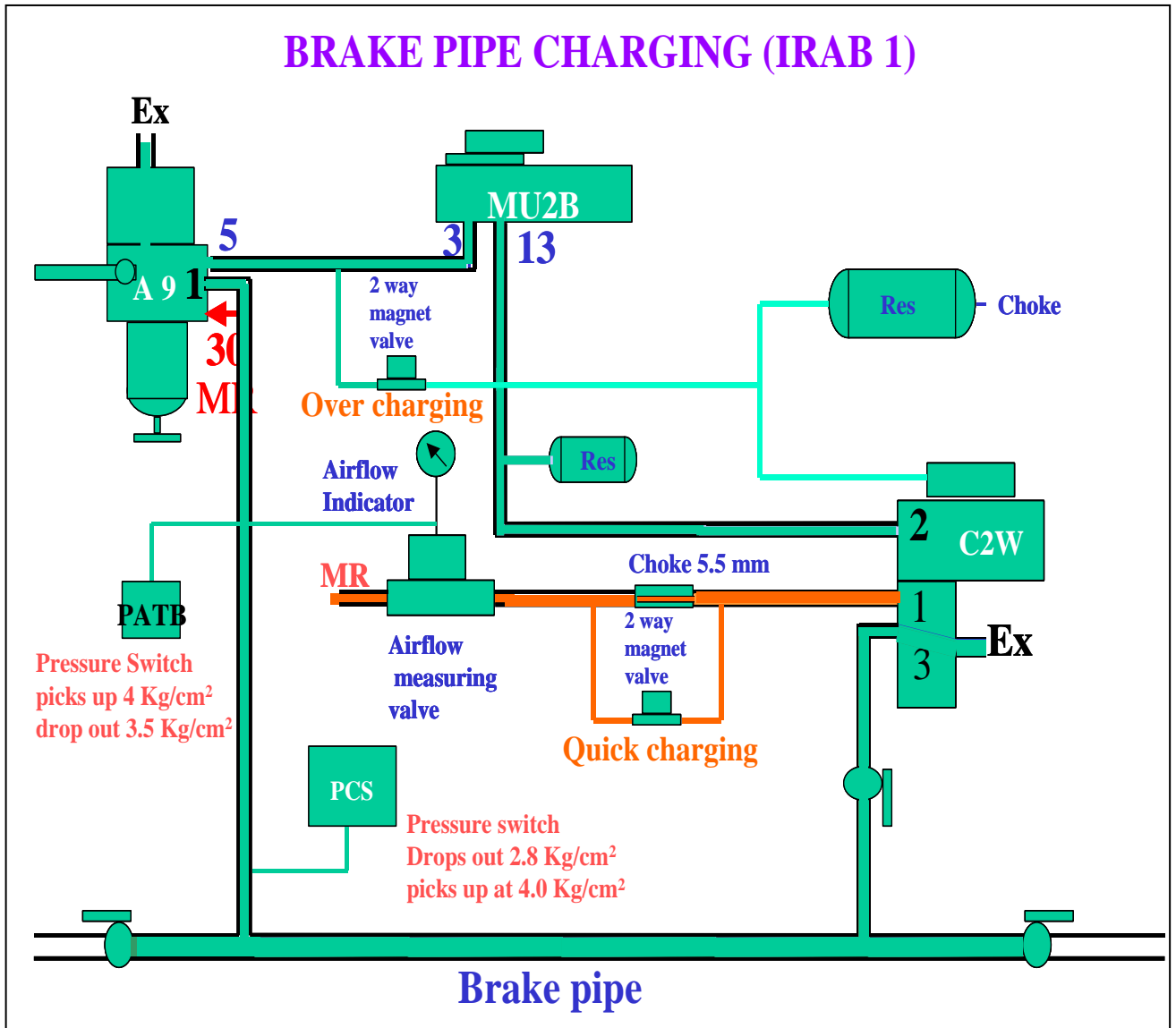

## **AUTOMATIC / CONJUNCTION BRAKE IN LOCOMOTIVES:**

The arrangements of valves are shown in sketch.

When there is a reduction in brake pipe, C3W valve senses it and supply air pressure proportional to the reduction in BP for the brake cylinder. This air passes through the limiting valve and then to F1 selector valve Port 4. If the MU2B and also F1 selector are in lead, this pressure flows to the C2 relay valve port 2 through the double check valve and applies the loco brakes. When the BP is recharged, C<sub>3</sub>W valve will withdraw the air and exhaust it causing the C2 relay to release the brakes in the loco.

## **ACTION ON DYNAMIC BRAKE APPLICATION:**

If dynamic brakes are applied, (while the Automatic brake is also ON) D1 pilot air valve fitted in between limiting valve and F1 selector will be energized causing the normal passage to cut off and air applied to C2 relay through F1 selector to be exhausted. This causes the loco brakes to release. This feature is provided to avoid excess (two brakes ON at a line) braking in loco and hence wheel skidding. When DB is released, normal operation of automatic brake is restored.

## **OVER CHARGING FUNCTION:**

Generally, if there is brake binding in any of the vehicle in formation, the crew has to reach the particular vehicle and release the brakes manually. It will take several minutes. To avoid delay due to brake binding, the brake pipe is charged more than 5 Kg/cm<sup>2</sup> (i.e., 5 Kg/Cm<sup>2</sup> max). By doing so, the C3W valves of all the vehicles will be forced to release the brakes, because as per general logic brake releases when BP is equal to or more than CR. This is done by the overcharging function in this system.

For overcharging, the crew should press overcharging button, in certain cases switch. This switch energizes the 2-way magnet valve, supplying BP pilot air to C<sub>2</sub>W relay valve. This pressure increases the setting of C<sub>2</sub>W valve to 5.4 Kg/Cm<sup>2</sup> (this is done by charging the top diaphragm to an additional value). The overcharging continues till the button/ switch hold pressed. It is advisable not to allow the BP to

rise more unnecessarily long time to resume the normal operation. The switch should be released as soon as the BP rises to 5.2 Kg/Cm<sup>2</sup>.

## CO-ORDINATED BRAKING APPLICATION

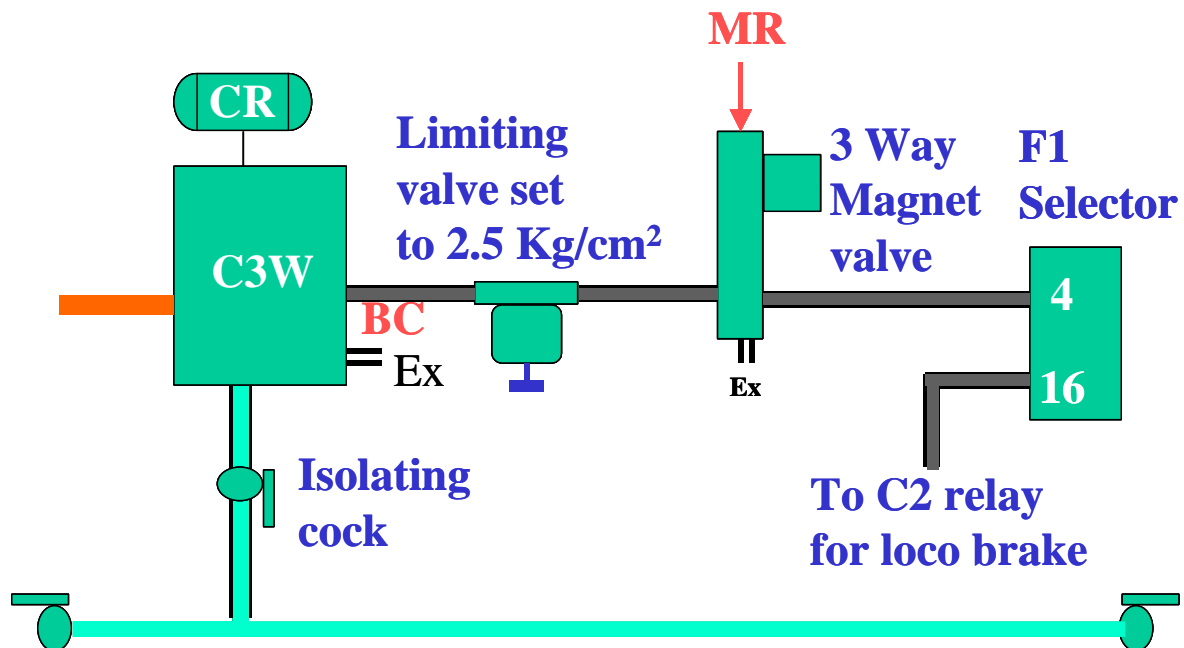

### QUICK CHARGING FUNCTION:

Normally to meet the leakages in the BP line during running condition a 5.5 mm choke is provided at the inlet to the C2 relay valve, the purpose of providing choke is just to meet the loss of BP during run. Otherwise excess rate of charging will not reduce the BP for application of brake and indication in case of Chain pulling / guard's brake application. But during initial charging and releasing of brake BP need to be charged faster. To charge the pipes faster, a bypass for this choke is provided with a 2 way magnet valve. On energizing the magnet valve, the choke is bypassed to normal opening  $\frac{3}{4}$ ", resuming the normal capacity of C<sub>2</sub>W relay valve. This should be used to avoid auto flasher to switch ON during releasing the brakes (which takes place if the charging time is more than 60 sec)

## **SAFETY DEVICES**

These safety devices are shown in the sketches.

### **A9 EMERGENCY:**

The A9 emergency is applied BP will be reduced to zero. When the pressure is less than 2.5Kg/Cm<sup>2</sup> the PCS operate and brings the engine to idle.

### **TRAIN PARTING:**

When train parting occurs, air leaks out heavily through the brake pipe causing Airflow indicator to shoot up. When the reading goes beyond 80 wagons (4.0 Kg/cm<sup>2</sup>) at the indicator pipe, the PCS operates and brings the engine to idle. If the trouble is rectified and the reading reduces to 70 wagons, (3.5 Kg/ Cm<sup>2</sup> at the indication pipe) this PCS resets and allow the engine to rise.

## **DIESEL LOCOMOTIVE TWIN PIPE DUAL BRAKE SYSTEM**

### **INTRODUCTION**

Diesel locomotives of Indian Railways are equipped with brake system designed by either M/S WABCO/ USA or M/S KNORR Germany or IRAB-1 Indian Railways or M/S KNORR Brake (NYAB). Initially locomotives were equipped with M/S WABCO, USA designed 28LV-1 Brake system for use in vacuum brake train only. In 80's locomotives were switched over to 28LAV-1 Brake system for use both in vacuum and air braked Trains.

In 90's some of the locomotives were equipped with IRAB-1 brake system, which are suitable for only air-braked trains. Recently acquired WDG4 and WDP4 locomotives are equipped with CCB (computer control brake) system designed by KNORR BRIMSE (NYAB), which are suitable for air braked train only.

### **Important feature of the 28LAV-1 brake system**

1. Locomotive brakes may be applied with any desired pressure between the minimum and maximum. This pressure will be maintained automatically in the locomotive brake cylinders against normal leakage from them



2. The locomotive brakes can be graduated on & off with either the automatic or the independent brake valve.
3. It is always possible to release the locomotive brakes with the independent brake valve, even when automatically applied.
4. The maximum braking position emergency, ensuring the shortest possible stops distance.
5. It is always possible to haul both vacuum / air brake trains.
6. Automatic brake application and power cut off with idle rpm of engine is always possible during train parting.
7. Multiple unit operation is also possible.

## **INDEPENDENT BRAKE SYSTEM (LOCO BRAKE)**

### **Introduction:**

Loco brake system is provided to stop the Locomotive, whenever it runs as light engine. It is purely compressed air brake system known as independent brake system. For this separate air circuit is provided in 28LAV-1 & IRAB-1 Brake system which is independent to other air circuit. SA9 Independent brake valve is provided in driving control stand for application & release of loco brake. Valve has three positions i.e. quick release, release and application.

### **Purpose of this system:**

Independent Brake System is designed to apply and release brake on locomotive only, especially when the locomotive is moving independently.

### **System brake valves:**

System consists of SA9 Independent Brake valve, Double check valve and C2-Relay valve.

### **Description of loco brake (Independent brake) system**

The SA9 Valve handle is kept normally in release position (right side). MR air is always available at port no.30 of SA9 valve. When handle is brought in application position (left side) than SA9 port 30 connects port 20 and starts supplying pilot air to C2-Relay air valve. The pilot air passes through MU2B Valve port no. 2&20 and

inters to C2-Relay at port no.2. See the line diagram of loco brake system. The pilot air pressure depends upon the handle position; in full application it is 3.5kg/cm<sup>2</sup>. The C2-relay air valve actuates after getting pilot air and connects MR pressure to brake cylinders of locomotive through port no.1&3. The brake cylinder pressure depends upon pilot air pressure, supplied into C2-Relay chamber through port no.2. For full brake application SA9 handle is moved to maximum travel position. In this way independent brake/loco brake is applied. Gauge line connection is taken from BC pipe near front truck of locomotive to the driver's control stand for indicating brake cylinder pressure. When SA9 handle is placed in release position, loco brakes are released. For detailed understanding see the internal function of the SA9 valve & C2-Relay valve.

SA9 Brake valve handle is normally kept in release position. It can be applied to any desired pressure between the minimum and maximum through SA9 valve handle. This pressure will be automatically maintained in the locomotive brake cylinders against normal leakage from them. The locomotive brake can be graduated on and off with either the automatic (A9) or the independent brake valves (SA9). It is always possible to release the locomotive brakes with the SA9 valve.

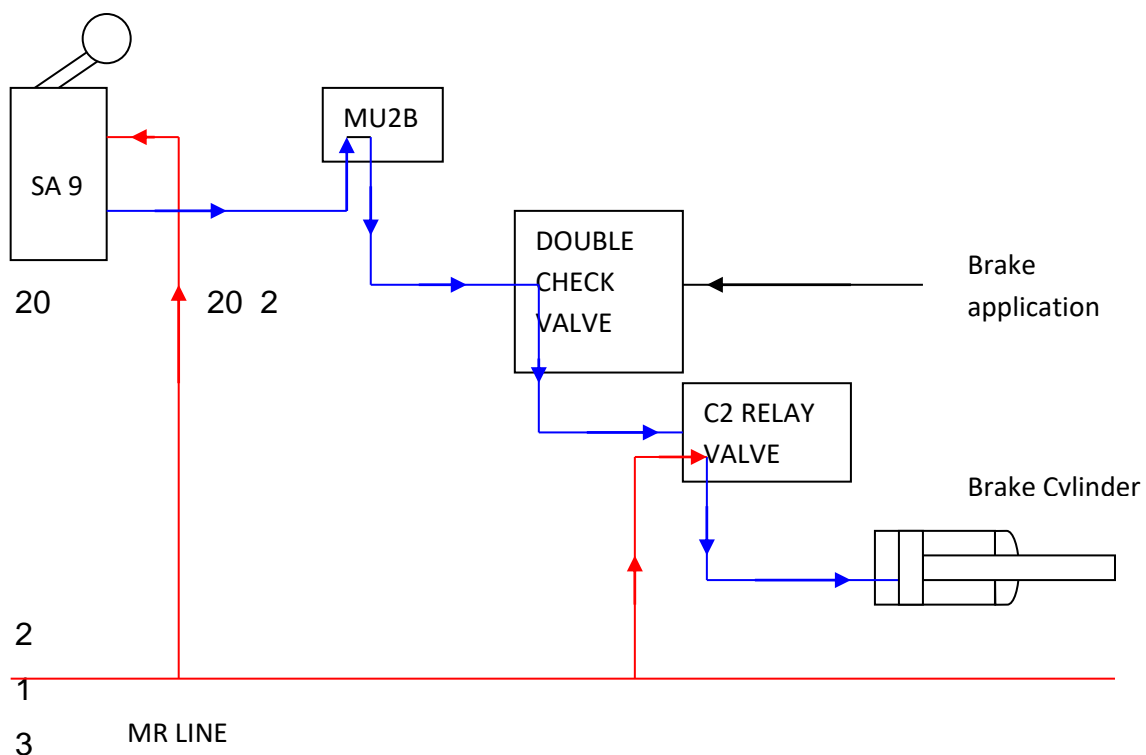

**INDEPENDENT BRAKE APPLICATION**

## INDEPENDENT BRAKE SYSTEM LAYOUT

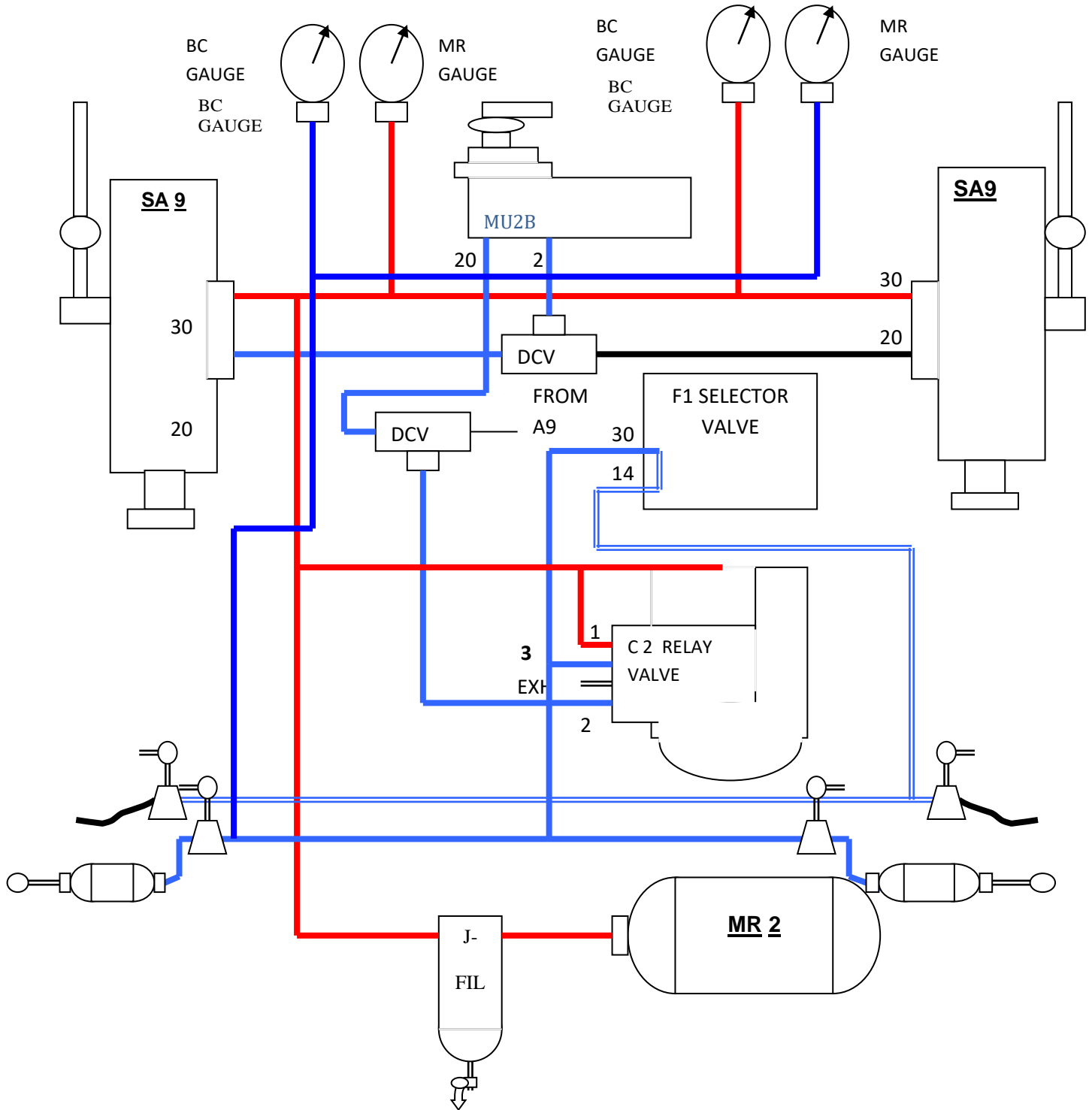

# **VACCUM BRAKE SYSTEM**

## **INTRODUCTION**

Indian Railway runs both the trains vacuum and air brake. In vacuum brake train brakes are controlled through vacuum of train pipe. After coupling the locomotive with the vacuum brake train the vacuum hoses are connected to obtain vacuum in train pipe. The exhauster unit of the locomotive is connected with vacuum train pipe through a vacuum control valve (VA1A/ VA1B), to create the vacuum in the train pipe as well as the Vacuum cylinders of each coach/wagon. A9 automatic brake valve is provided in driving control stand through which vacuum is controlled for application and release of brake. Normally valve handle is kept in release position.

## **PURPOSE OF THIS SYSTEM**

This system is designed to apply and release brakes on vacuum brake train. Which is achieved through A9 Automatic Brake valve.

## **VACUUM BRAKE SYSTEM VALVES**

System consists of A9 Automatic Brake valve, VA1B Control valve and HS4 Control valve.

## **DESCRIPTION OF VACCUM BRAKE SYSTEM**

Locomotive and train has a long vacuum brake pipe, in which 56cm vac. is maintained through an exhauster unit and a vacuum control valve (VA1A/ VA1B). A9 automatic brake valve is provided in driving control stand to apply vacuum brake in the train. When A9 handle is placed in application zone, train pipe vacuum drops and brakes are applied through vacuum cylinders of coaches.

The function of A9 valve is to supply Brake Pipe pressure in 28 LV1 system or to provide control air pressure to Add.C2-Relay valve for charging Brake Pipe in 28 LAV1 system. The function of VA1B control valve is to control vacuum according to control air pressure of Brake Pipe. The function of HS4 valve is to supply 1.7kg/cm<sup>2</sup>-air pressure to bottom chamber of VA1B control valve at port no.1. Other valves are provided in this circuit for MU operation. See line diagram of vacuum brake circuit.

## **CHARGING OF SYSTEM**

Air at 8 to 10kg/cm<sup>2</sup> pressure is charged at different valves through MR-2 (See the line diagram of vacuum system) i.e. at port no.30 of A9 valve, port no.1 of Add.C2-Relay valve and port no.1 of HS4 control pressure valve. A9 valve handle is kept at release position normally. In release position, A9 valve will supply control pressure to additional C2-Relay valve through MU2B valve. After getting supply of control pressure, Add.c2-relay valve will charge BP according to control Air Pressure. BP pipe is connected to VA1B control valve top chamber at port no.3. At port no.1 control pressure at 1.7kg/cm<sup>2</sup> is supplied through HS4 control valve. VA1-B control valve maintains 56cm vacuum in train pipe by connecting it to Expressor.

## **APPLICATION OF BRAKE**

A9 handle is moved in application zone for brake application. A9 reduces Control pressure to Add.C2 Relay valve. Add. C2 Relay reduces BP pressure in proportion to control pressure droppage. BP pressure drops to zero if A9 handle is moved at over reduction position. If handle is placed at emergency position BP will drop to zero immediately within 3 sec. Due to dropping BP pressure, brakes are applied in train through distributor valve in case of air brake train. In case of vacuum brake train, control pressure at the top chamber of VA1B control valve is dropped, which causes movement of spool valve connecting train pipe to atmosphere and applies brake.

## **RELEASING OF BRAKE**

When handle is moved to release position, A9 valve starts supplying full control pressure to additional C2 Relay valve, which in turn charges Brake Pipe. When pressure increases to 5kg/cm<sup>2</sup> and brakes are fully release.

### VACUUM BRAKE RELEASE POSITION

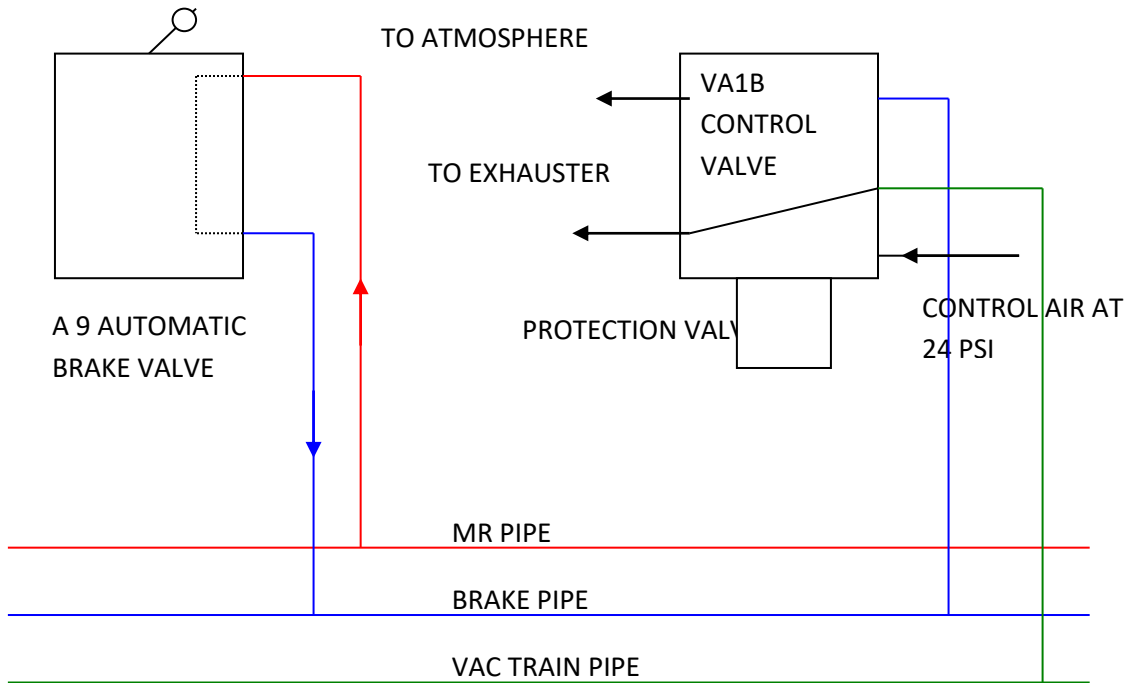

### VACUUM BRAKE APPLICATION POSITION

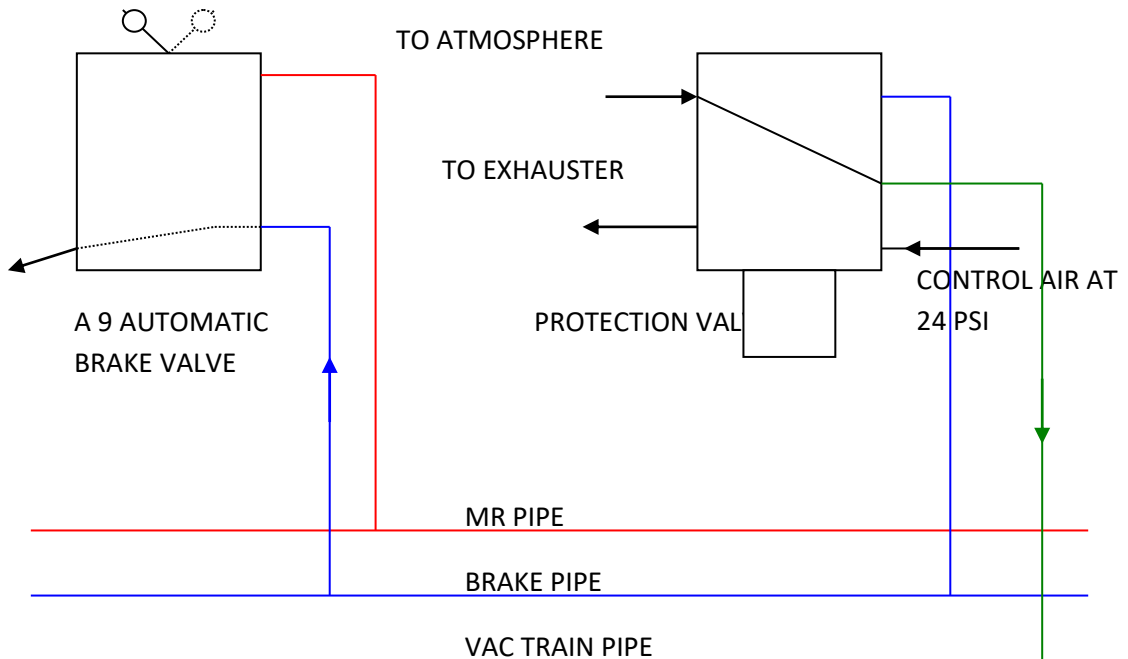

VACUUM BRAKE SYSTEM

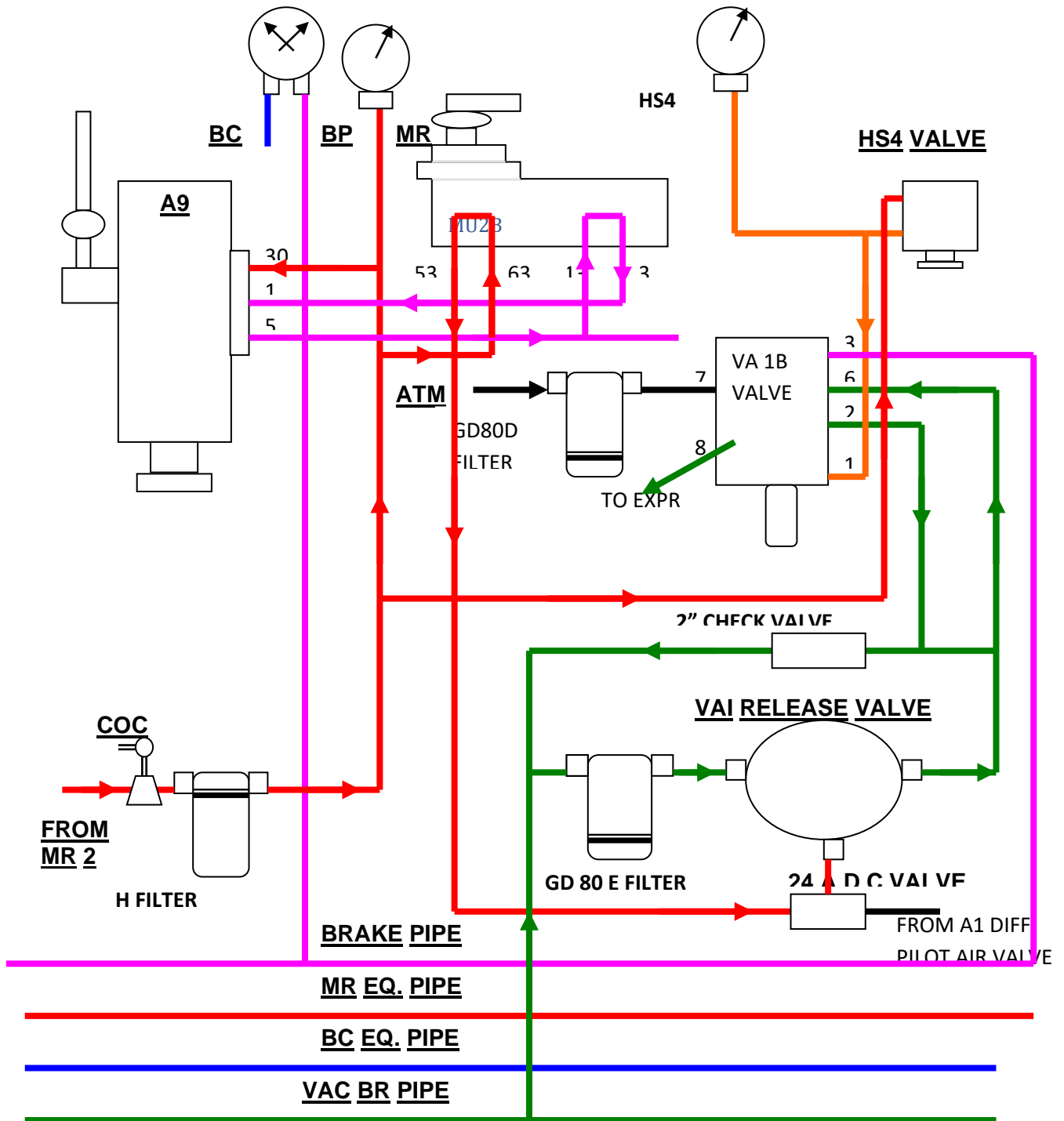

## VACUUM TROUBLE IN TRAIN

Following test are recommended:-

1. BLOCKAGE TEST: Remove one end of the vacuum hose pipe and raise it upwards. If more than 8cm vacuum is created, there is a blockage in the system.
2. EFFICIENCY TEST: Against an 8 mm leak disc, the loco should create 53 cm vacuum.
3. LEAKAGE TEST: Vacuum on dummy and on leak disc should not vary more than 3 cm.

The Board has therefore standardized the vacuum level in engine and brake van for all Railways in both the traction.

Type of service	Engine	Brake van	Average
M/E	53	47	50
Passenger	50	44	47
Goods	46	38	42



### 3.FUEL OIL SYSTEM

#### INTRODUCTION

All locomotive units have individual fuel oil system. The fuel oil system is designed to introduce fuel oil into the engine cylinders at the correct time, at correct pressure, at correct quantity and correctly atomized. The system injects into the cylinder correctly metered amount of fuel in highly atomized form. High pressure of fuel is required to lift the nozzle valve and for better penetration of fuel into the combustion chamber. High pressure also helps in proper atomization so that the small droplets come in better contact with the fresh air in the combustion chamber, resulting in better combustion. Metering of fuel quantity is important because the locomotive engine is a variable speed and variable load engine with variable requirement of fuel. Time of fuel injection is also important for better combustion.

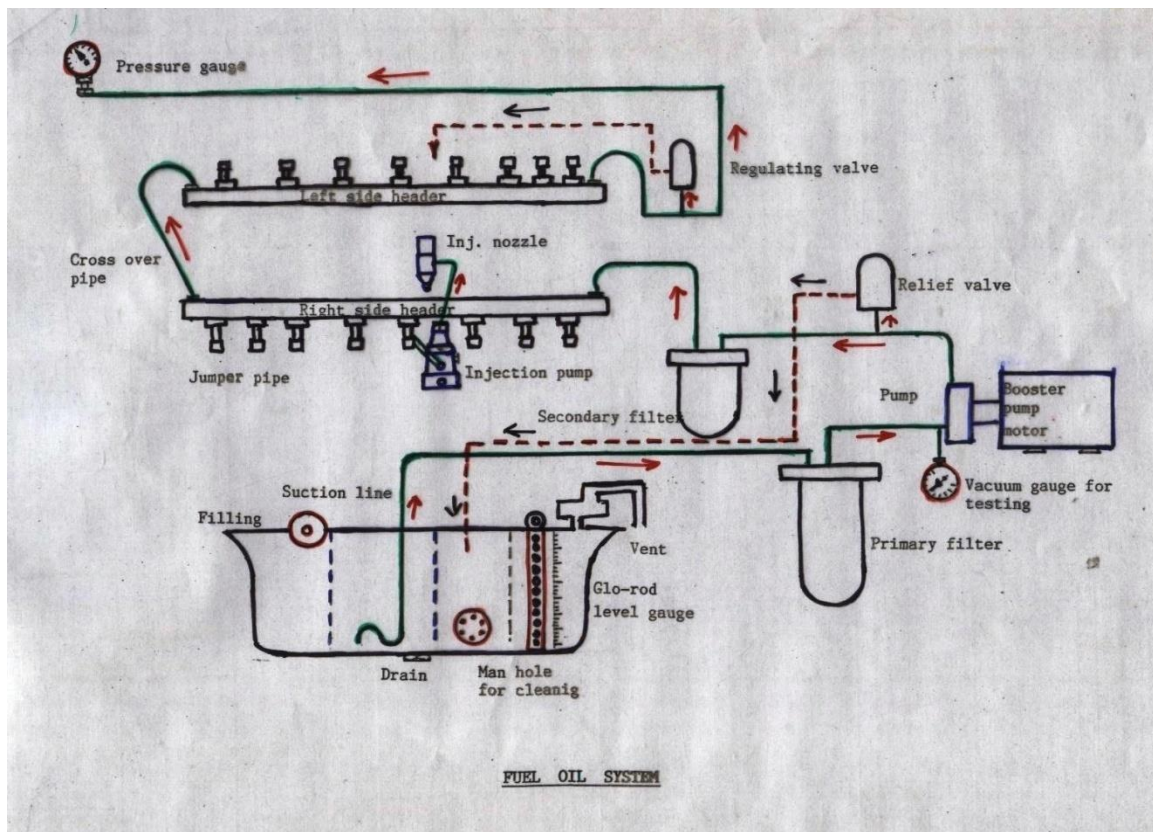

FUEL OIL SYSTEM

The fuel oil system consists of two integrated systems.

- Fuel feed system.
- Fuel injection system.

### **FUEL FEED SYSTEM AND ITS ASSOCIATE COMPONENTS**

Fuel feed system provides the back-up support to the fuel injection pumps by maintaining steady supply of fuel to them at the required pressure so that the fuel pump can meter and deliver the oil to the cylinder at correct pressure and time. The fuel feed system includes the following:-

#### **Fuel oil tank:**

A fuel oil tank of required capacity (normally 5000ltrs), is fabricated under the superstructure of the locomotive and located in between the two bogies. Baffle walls are used inside it to arrest surge of oil when the locomotive is moving. A strainer filter at the filling plug, an indirect vent, drain plug, and glow rod type level indicators are also provided.

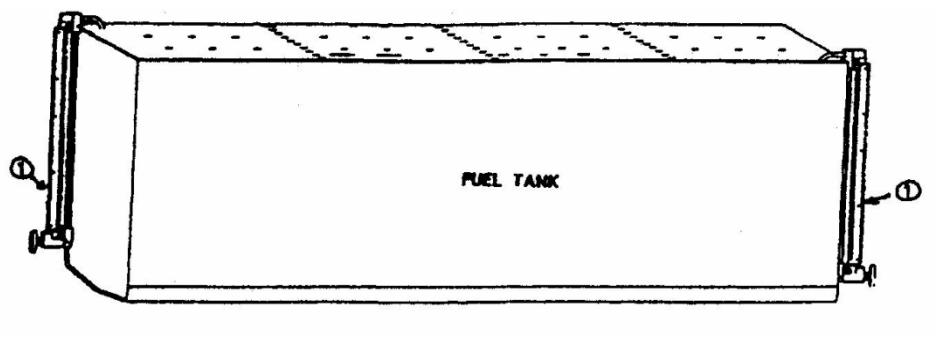

FUEL OIL TANK

#### **Fuel primary filter:**

A filter is provided on the suction side of the fuel transfer pump to allow only filtered oil into the pump. This enhances the working life of the fuel transfer pump. This filter is most often a renewable bleached cotton waste packed filter, commonly known as socks type filter element. These socks type filters are coarse filters and have a greater ability to absorb moisture, and are economical. However, in certain places, it has been replaced by paper type filter, which have longer service life.

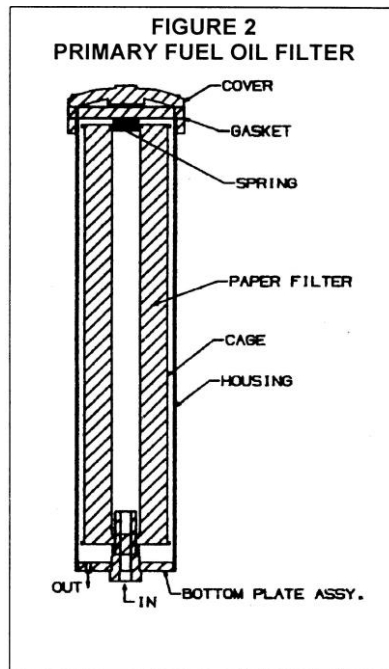

PRIMARY FUEL OIL FILTER

**Fuel transfer pump or booster pump:**

The fuel feed system has a transfer pump to lift the fuel from the tank. The gear type pump is driven by a dc motor, which is run by storage batteries through a suitable circuit. The pump capacity is 14 litres per minute at 1725 rpm at pressure 4 to 4.8 kg/sq.cm.

**Fuel relief valve:**

The spring- loaded relief valve is meant for by passing excess oil back to the fuel tank, thus releasing excess load on the pump and on the motor, to ensure their safety. It is adjusted to a required pressure (normally 5 kg/cm<sup>2</sup>), and it by- passes the excess fuel back to the oil tank. It also ensures the safety of the secondary filter and the pipe lines.

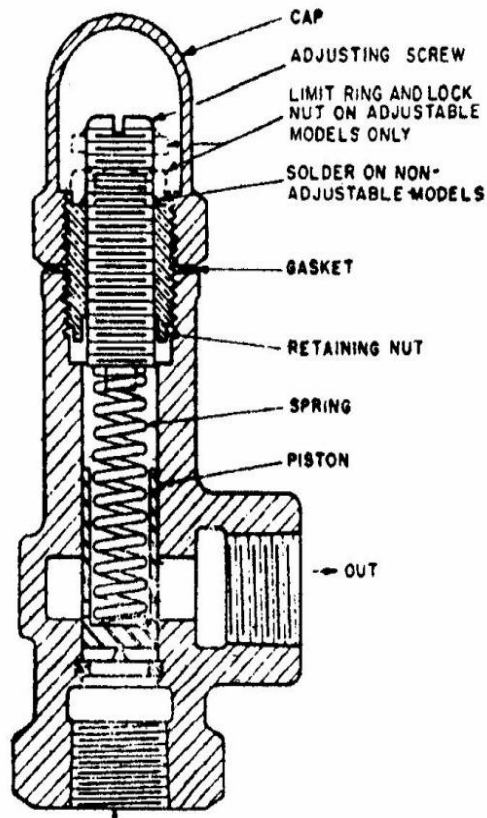

FUEL RELIEF AND REGULATING VALVE

**Fuel secondary filter:**

The fuel secondary filter is located after the booster pump in the fuel feed system. The filter used is a paper type filter, cartridge of finer quality, renewable at regular intervals. This filter arrests the finer dirt particles left over by the primary filter and ensures longer life of the fuel injection equipments.

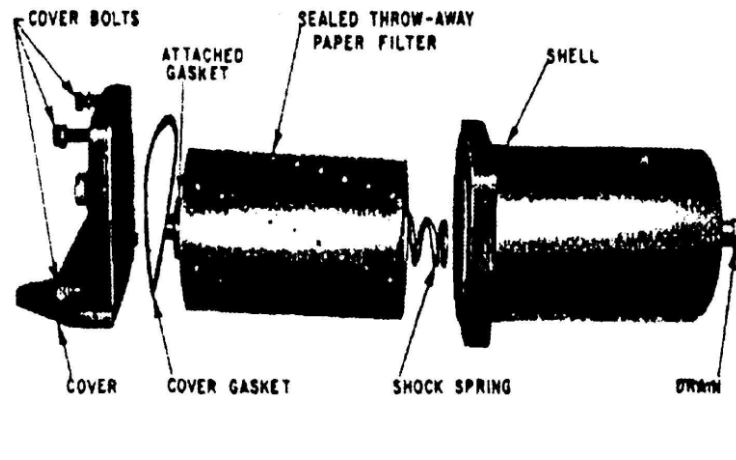

SECONDARY FUEL OIL FILTER

**Fuel regulating valve:**

The fuel-regulating valve is spring-loaded valve of similar design as the fuel relief valve. It is located after the secondary filter in the fuel feed system. This valve is adjusted to the required pressure (3 kg/cm<sup>2</sup>), and always maintains the same pressure in the fuel feed system by releasing the excess oil to the fuel oil tank. There is no by-passing of oil if the pressure is less than the adjusted level.

**FUNCTIONING OF FUEL FEED SYSTEM**

The fuel booster pump or transfer pump is switched on and the pump starts sucking oil from the fuel oil tank, filtered through the primary filter. Because of variable consumption by the engine, the delivery pressure of the pump may rise increasing load on the pump and its drive motor. When the rate of consumption of the fuel by the engine is low, the relief valve ensures the safety of the components by releasing load, by-passing the excess pressure back to the tank. Then oil passes through the paper type secondary filter and proceeds to the right side fuel header. The fuel header is connected to eight numbers of fuel injection pumps on the right-bank of the engine, and a steady oil supply is maintained to the pumps at a pressure of 3 Kg./ sq. cm. Then the fuel oil passes on to the left side header and reaches eight fuel injection pumps on the left bank through jumper pipes. The regulating

valve remaining after the left side fuel header, takes care of excess pressure over 3 Kg/cm Square by passing the extra oil back to the tank. A gauge connection is taken from here leading to the driver's cabin for indicating the fuel oil feed pressure. Thus the fuel feed system keeps fuel continuously available to the fuel injection pumps, which the pumps may use or refuse depending on the demand of the engine.

## **FUEL INJECTION SYSTEM**

When diesel engine is started, all fuel injection pumps start functioning. According to firing order all F.I. pumps start discharging fuel oil at high pressure to their respective nozzles through high pressure line tube. Fuel injection nozzle injects fuel oil to combustion chamber at 4000 psi. The internal function of F.I. pump and nozzle are described below.

### **Fuel Injection Pump:**

It is a constant stroke plunger type pump with variable quantity of fuel delivery to suit the demands of the engine. The fuel cam controls the pumping stroke of the plunger. The length of the stroke of the plunger and the time of the stroke is dependent on the cam angle and cam profile, and the plunger spring controls the return stroke of the plunger. The plunger moves inside the barrel, which has very close tolerances with the plunger. When the plunger reaches to the BDC, spill ports in the barrel, which are connected to the fuel feed system, open up. Oil then fills up the empty space inside the barrel. At the correct time in the diesel cycle, the fuel cam pushes the plunger forward, and the moving plunger covers the spill ports. Thus, the oil trapped in the barrel is forced out through the delivery valve to be injected into the combustion chamber through the injection nozzle. The plunger has two identical helical grooves or helix cut at the top edge with the relief slot. At the bottom of the plunger, there is a lug to fit into the slot of the control sleeve. When the rotation of the engine moves the camshaft, the fuel cam moves the plunger to make the upward stroke. It may also rotate slightly, if necessary through the engine governor, control shaft, control rack, and control sleeve. This rotary movement of the plunger along with reciprocating stroke changes the position of the helical relief in respect to the spill port and oil, instead of being delivered through the pump outlet, escapes back to the low pressure feed system. The governor for engine speed control, on sensing the

requirement of fuel, controls the rotary motion of the plunger, while it also has reciprocating pumping strokes. Thus, the alignment of helix relief with the spill ports will determine the effectiveness of the stroke. If the helix is constantly in alignment with the spill ports, it bypasses the entire amount of oil, and nothing is delivered by the pump. The engine stops because of no fuel injected, and this is known as 'NO-FUEL' position. When alignment of helix relief with spill port is delayed, it results in a partly effective stroke and engine runs at low speed and power output is not the maximum. When the helix is not in alignment with the spill port throughout the stroke, this is known as 'FULL FUEL POSITION', because the entire stroke is effective. Oil is then passed through the delivery valve, which is spring loaded. It opens at the oil pressure developed by the pump plunger. This helps in increasing the delivery pressure of oil. It functions as a non-return valve, retaining oil in the high pressure line. This also helps in snap termination of fuel injection, to arrest the tendency of dribbling during the fuel injection. The specially designed delivery valve opens up due to the pressure built up by the pumping stroke of plunger. When the oil pressure drops inside the barrel, the landing on the valve moves backward to increase the space available in the high-pressure line. Thus, the pressure inside the high-pressure line collapses, helping in snap termination of fuel injection. This reduces the chances of dribbling at the beginning or end of fuel injection through the fuel injection nozzles.

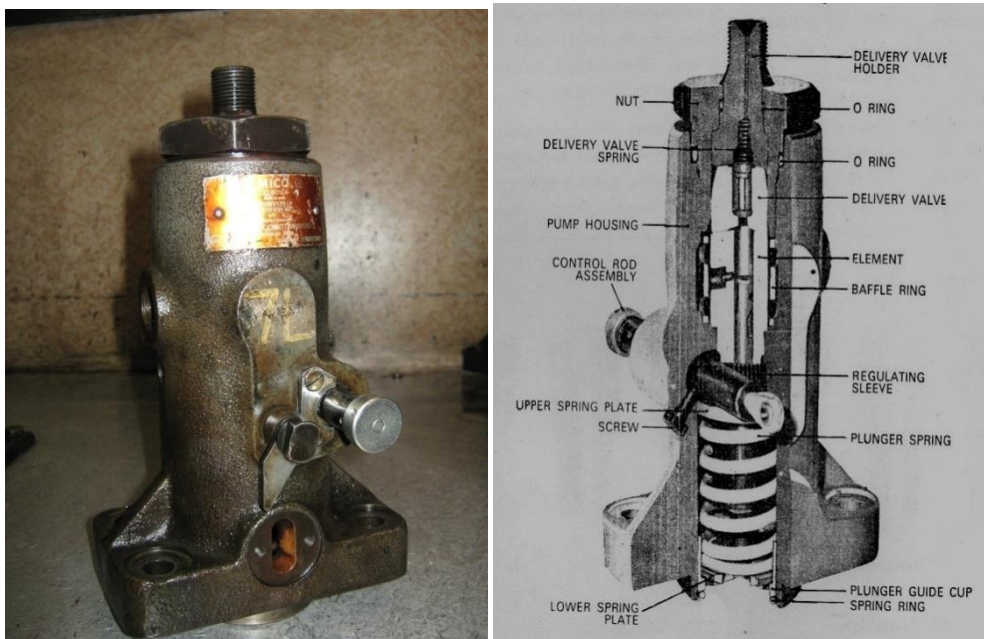

FUEL INJECTION PUMP

## Fuel Injection Nozzle:

The fuel injection nozzle or the fuel injector is fitted in the cylinder head with its tip projected inside the combustion chamber. It remains connected to the respective fuel injection pump with a steel tube known as fuel high pressure line. The fuel injection nozzle is of multi-hole needle valve type operating against spring tension. The needle valve closes the oil holes by blocking the oil holes due to spring pressure. Proper angle on the valve and the valve seat, and perfect bearing ensures proper closing of the valve.

Due to the delivery stroke of the fuel injection pump, pressure of fuel oil in the fuel duct and the pressure chamber inside the nozzle increases. When the pressure of oil is higher than the valve spring pressure, valve moves away from its seat, which uncovers the small holes in the nozzle tip. High-pressure oil is then injected into the combustion chamber through these holes in a highly atomised form. Due to injection, hydraulic pressure drops, and the valve returns back to its seat terminating the fuel injection, termination of fuel injection may also be due to the bypassing of fuel injection through the helix in the fuel injection pump causing a sudden drop in pressure.

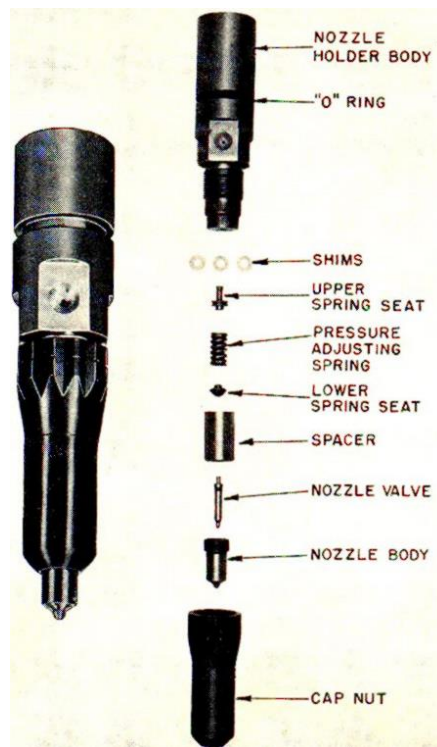

INJECTOR



## SUMMARY:

Fuel Feed System is responsible for supply of clean oil with adequate quantity at required pressure to Fuel Injection System, to meet the requirement of fuel oil of the engine at rated output. In Fuel Feed System, Fuel tank acts as reservoir of HSD oil of the engine; Primary and Secondary filters maintain cleanliness of oil in the system. Fuel Booster Pump works for generating pressure and maintaining adequate supply of fuel in the system; Relief and Regulating Valves maintain constant pressure in the feed system.

Fuel Injection System comprises of mainly two components.

- (a) Fuel Injection Pump.
- (b) Fuel Injection Nozzle.

Fuel Injection Pump is a plunger type Pump having constant stroke with variable delivery. The quantity of fuel delivered is decided by the position of the helix groove that varies with the twisting of the plunger according to the fuel rack position. Hence it is responsible for supplying correct quantity of pressurized fuel up to the nozzle. Nozzle is responsible for delivering pressurized fuel in atomized form into the combustion chamber. The breaking pressure i.e. the final pressure at which fuel is released into the combustion chamber is decided by the setting of

Nozzle	Valve	Spring	pressure.
--------	-------	--------	-----------

**FIGURE 1**  
**NUMBERING SEQUENCE INDICATES OIL FLOW THROUGH THE SYSTEM**

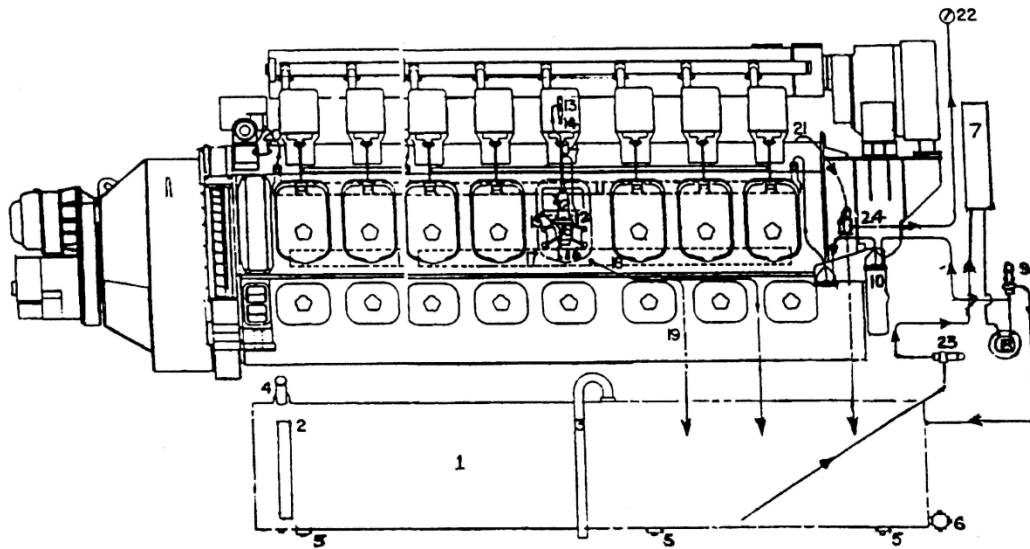

Numbering sequence indicated oil flow through the system

- |                                  |   |                                       |
|----------------------------------|---|---------------------------------------|
| 1-Fuel Tank                      | 10-Secondary Filter                     | 17-Drain Channel                      |
| 2-Fuel Level Gauge               | 11-Fuel Oil Header                      | 18-Drain to Tank (RS)                 |
| 3-Vent                           | 12-Injection Pump                       | 19-Drain to Tank (LS)                 |
| 4-Filter Pipe                    | 13-Injection Nozzle                     | 20-Header Crossover Line              |
| 5-Washout Plug                   | 14-Nozzle Leaknut                       | 21-Fuel Oil Rectum                    |
| 6-Condensation Drain             | 15-Drain From Control Shaft Compartment | 22-Pressure Gauge                     |
| 7-Primary Filter                 | 16-Drain From Fuel-Pump                 | 23-Fuel Trap                          |
| 8-Fuel Booster Pump              |   | 24-Pressure Regulating-Valve (35 psi) |
| 9-Pressure Relief-Valve (75 psi) |   |                                       |

## FUEL OIL SYSTEM

## **4.LUBE OIL SYSTEM**

### **(ALCO'S LUBE OIL SYSTEM)**

#### **PURPOSE OF LUBRICATION**

1. To reduce the friction and enable smooth operation between two moving surfaces.
2. To reduce wear and tear.
3. To reduce the temperature developed due to friction.
4. To clean and wash away the metal particles caused by wear and tear from the bearing surfaces.

#### **MAJOR COMPONENTS OF LUBE OIL SYSTEM**

1. Lube oil pump( Gear type)
2. Spring loaded Relief valve (Adjusted to 7.5 kg/cm<sup>2</sup>)
3. Lube oil filter tank (8 nos filter, pore size-12-16 micron)/Moatti filter
4. Conv. Lube oil cooler/Plate type lube oil cooler
5. Regulating valve
6. Centrifuge Cleaner(start at 2.5 kgf/cm<sup>2</sup>)
7. Oil sump
8. Lube oil strainer

#### **1. LUBE OIL PUMP:**

This is located at free end of engine slightly towards the right. Supply of oil in, adequate quantities and at the desired pressure is vitally depending upon the pump. A gear driven type pump has been provided. The gear pump is mounted on the free end of the engine base and is driven by the crankshaft gear. The suction line is in built into the engine base and the discharge is into the external piping.

The pump develops a partial vacuum, causing the fluid to flow into the pump inlet under atmospheric pressure. The fluid trapped between the helical gear

teeth and the pump housing is then injected out at the outlet side at a pressure. The delivery of the pump is directly proportional to the speed of rotation. The pump is designed to supply **1190 litres per minute** at **6.3 Kg/cm<sup>2</sup>** when the engine is operating at **1000 rpm** and the pump speed then is **1180 rpm**.



LUBE OIL PUMP (cut section)

## 2. RELIEF VALVE:

This Valve is fitted at the delivery side of the lube oil pump to ensure that oil pressure does not exceed a determined level. It is set at around **7.5 Kg/cm<sup>2</sup>** (105-110psi). This protects the system from damage due to excessive pressure on cold starting through by passing a portion of the oil to engine sump.

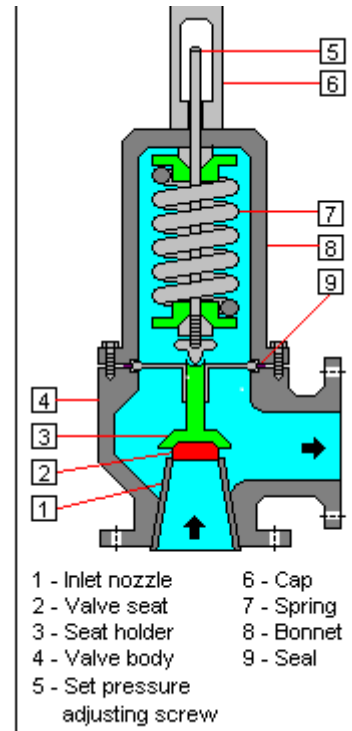
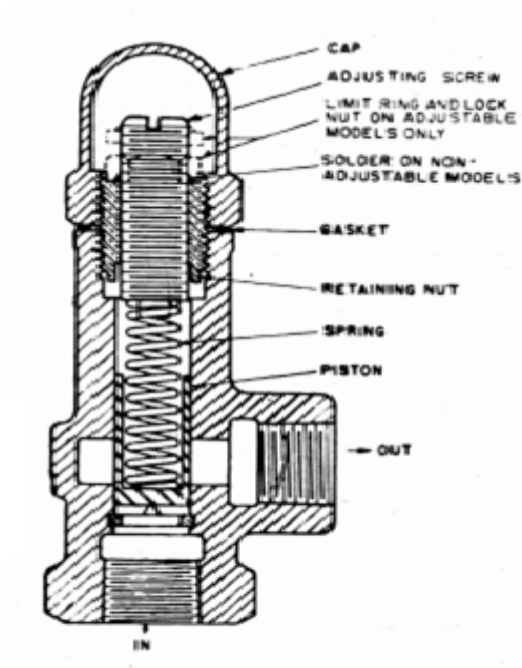

### RELIEF/REGULATING VALVE (CUT SECTION)

### 3. LUBE OIL FILTERS:

Paper type, disposable cartridge filters are used for the engine lube oil system. These filters are extremely fine and are required to trap contaminants to around 10 microns in size. The filters are located in radiator room. Two drain valves are provided in the filter tank as well as a vent line to eliminate any formation of air pockets.

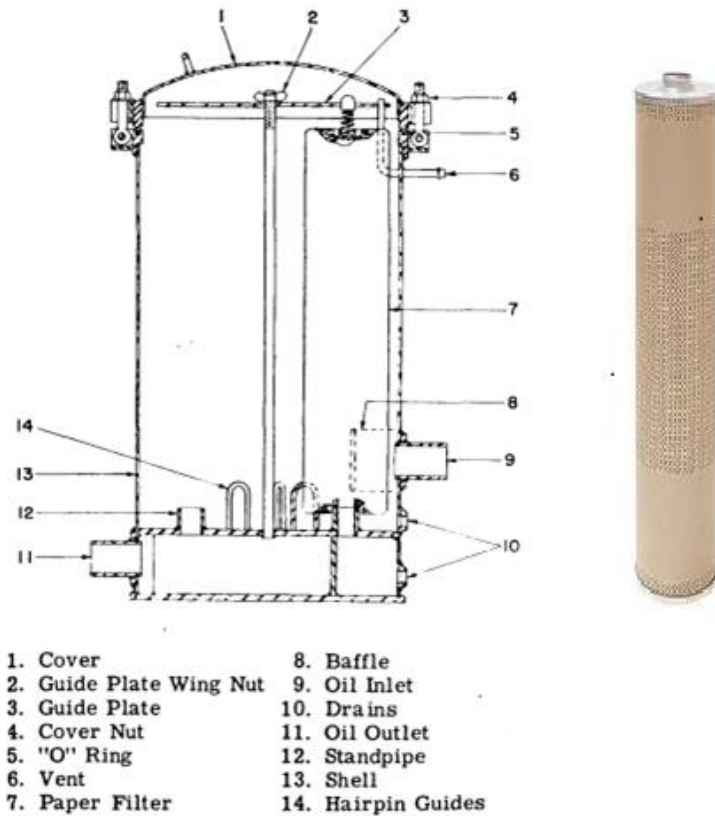

**Paper type lube oil filter**

**MOATTI FILTER:**

In the modified locos, Moatti type filters are used in place of paper type filters.

The Moatti filters are “Automatic back flushing” filters which cleans its filter elements by back flushing, thus decreasing the pressure drop across it.

The filter consists of

- The filter housing
- The filtering unit and distributor.
- The hydraulic motor

The filter housing can be divided into two chambers –

- First chamber, where the cleaning of the oil occurs is called “Full flow chamber”.

- The second chamber where the impurities stopped by the full flow chamber are collected is called “Diversion chamber”. The filter unit contains disc type filter elements placed on top of one another forming a very robust filter disc stack. The distributor, driven by the hydraulic motor, feeds unfiltered oil to all the columns except one that is open for back flushing. In this way, each column is back flushed once per rotation of distributor.

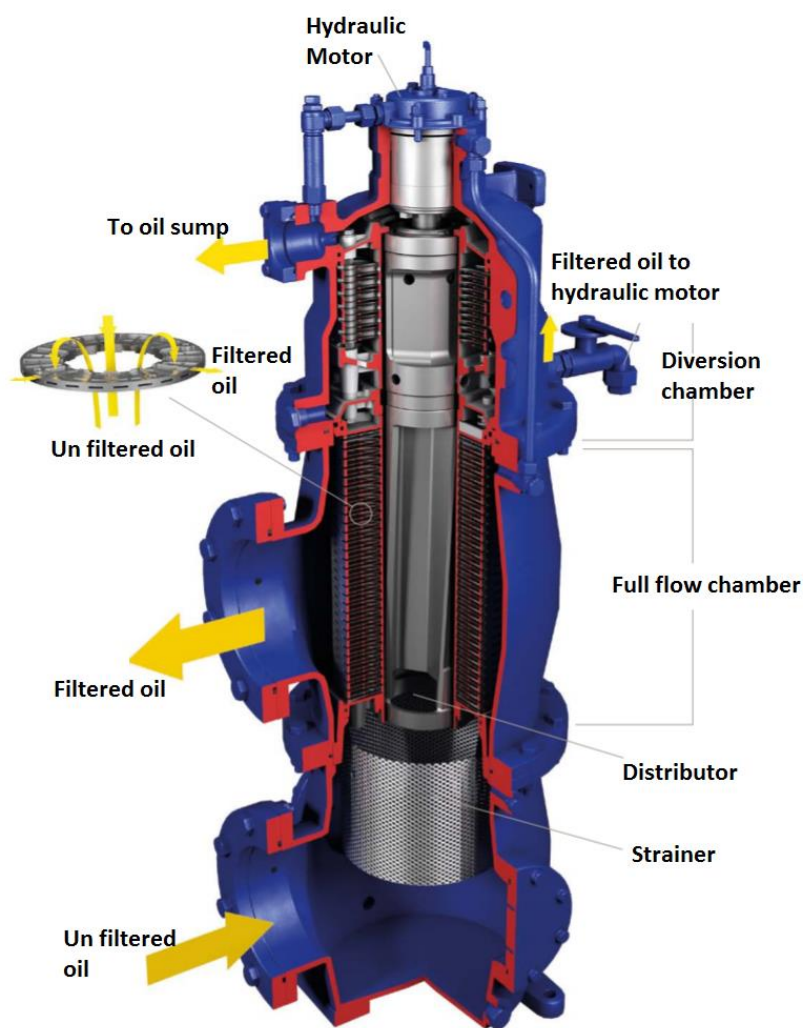

MOATTI FILTER

#### **4. CENTRIFUGE FILTER:**

In the modified locos, centrifuge filters are placed in parallel to the paper type filters for the effective filtering of the oil.

They provide the following advantages.

- Reduced engine wear.
- Longer oil change intervals.
- Longer filter life.
- Saves 400 litres of lube oil/loco/yr viz. oil lost in 8 filter changes
- No operating cost

The working of the centrifuge filter is as follows:

- The Separation in a centrifuge is effected purely by the centrifugal forces acting on the dirt particles.
- The oil is admitted into the centrifuge rotor under pressure from engine oil gallery.
- After circulation of the rotor, oil is ejected through a pair of nozzles at bottom of the rotor.
- This gives reaction force to the rotor and rotates it with dirty oil inside it about a shaft at about 600 rpm.
- Due to this rotation, the dirt particles inside rotor experience centrifugal force of about 2000 times gravity and are thrown out on the rotor wall.
- The particles stick on the rotor wall and form a sludge cake which is removed during servicing.



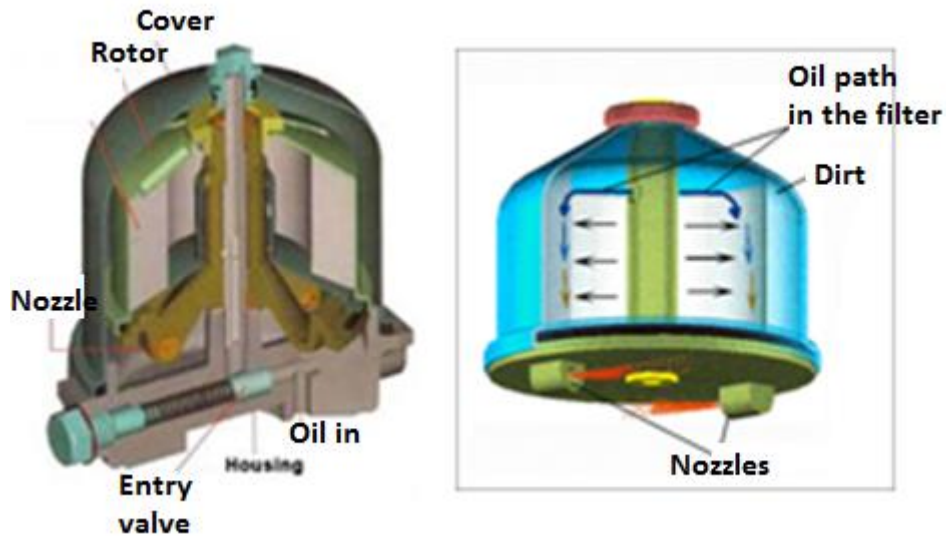

### CENTRIFUGE FILTER

#### 5. LUBE OIL COOLER

This is located in radiator room. Lube oil cooler is a heat exchanger, which removes unwanted heat from the engine oil and ensures supply of oil to the engine at a reasonable temperature.

The engine receives heat from two main sources that is the combustion heat and from bearing friction. In ALCO engines, lube oil is circulated through oil passages provided in the engine piston there by oil extracts substantial quantity of heat of combustion.

**Conventional lube oil cooler** is of shell and tube type heat exchanger, consisting of bundle of tubes enclosed shell. Cooling water from the radiator enters the cooler and flows through the tubes. Baffles are provided inside the shell to channel the oil flow around the tubes for removal of heat from the oil.

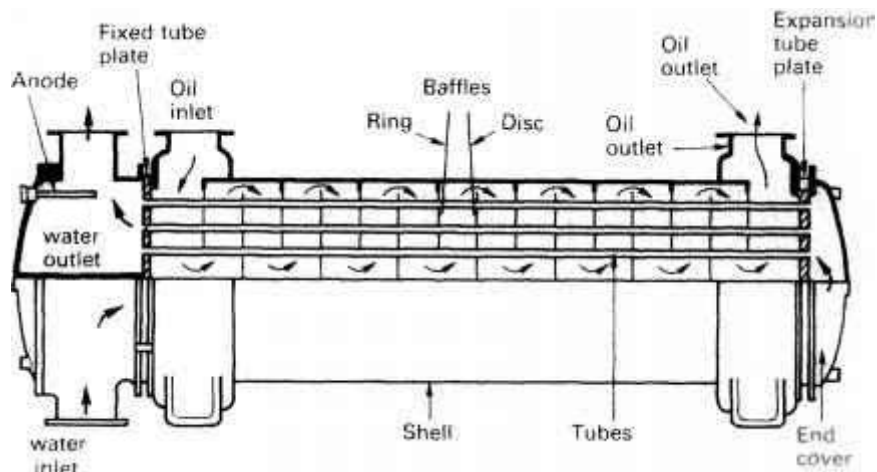

SHELL AND TUBE TYPE LUBE OIL COOLER

**Plate type cooler:** In Plate type cooler, alternate stainless steel plates with water & Lube Oil flows through the passages. Heat transfer rate has been improved *from 190 KW to 295 KW.*

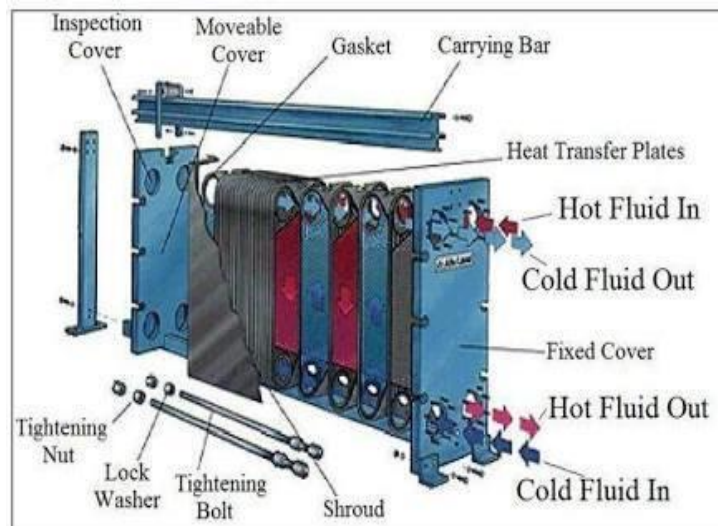

PLATE TYPE LUBE OIL COOLER

## **6. PRESSURE REGULATING VALVE:**

This located at the discharge side of the cooler and before the strainer. It regulates the flow of oil through the cooler and the lube oil pressure in the system. The setting of the valve is **4.2 Kg/cm<sup>2</sup>**. If the pressure is high, some of the oil is bypassed to the sump as a result of lifting of the valve.

**NOTE:** Regulating valve is not available in loco provided with Moatti type lube oil filters.

## **7. LUBE OIL STRAINER:**

The lube oil strainer is located at left side free end of the engine just before the lube oil header. The strainer removes coarse insoluble particles in the oil, which would be present normally in unfiltered oil only. Under normal operating conditions, the strainer will not trap any particles, as the paper type filters would have filtered all the particles. The strainer is essentially a last or final defence against contaminants. This is of gasket type with oil entering at the bottom, flows through a hollow tube to the top and into the space between the tube and a strainer screen. The oil then passes through the fine screen and goes out of the strainer shell.

**NOTE:** Lube oil strainer is not available in loco provided with Moatti type lube oil filters.

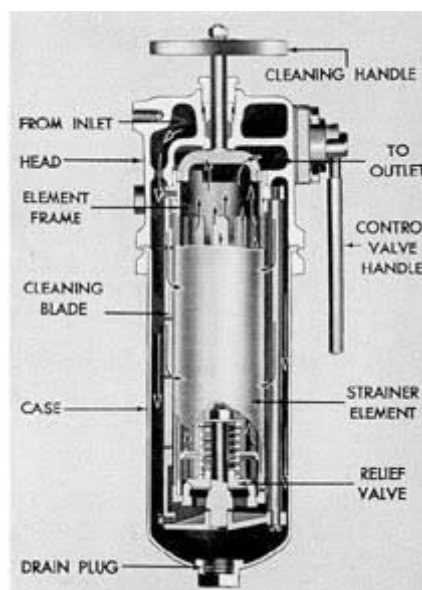

**LUBE OIL STRAINER**

## 8. LOW LUBE OIL PRESSURE SWITCH:

This is provided to protect the engine from low lubricating oil pressure by operating at a predetermined pressure and shutting down the engine with bell ringing and amber light simultaneously. The setting of OPS is closing at 1.6 Kg/cm<sup>2</sup> and opens at 1.3 Kg/cm<sup>2</sup>. Normally a steady oil pressure under idling conditions, at water temperature of 80 °C is obtained in the region of 2.5 Kg/cm<sup>2</sup>. When suddenly notching down, the transient low pressure may be 5-7psi below the steady pressure. So to obviate the possibility of engine shut down the LOPS setting could be 1.6 Kg/cm<sup>2</sup>. For engines using steel cap pistons an additional OPS is provided which causes shut down of the engine if oil pressure goes below 3.2 Kg/cm<sup>2</sup> on 7<sup>th</sup> or 8<sup>th</sup> notch. (It picks up at 3.5 Kg/cm<sup>2</sup> and drops at 3.2 Kg/cm<sup>2</sup>). With a low pressure in the system, caused by any reason, the lube oil loses its load carrying capacity between the bearings. As this is an important duty and purpose of the lube oil system in our locos the diesel engine has to be protected from any possible damage to the components due to lack of lubrication or lack of cooling oil in the piston crown. This switch is provided in the locos fitted with GE governor.

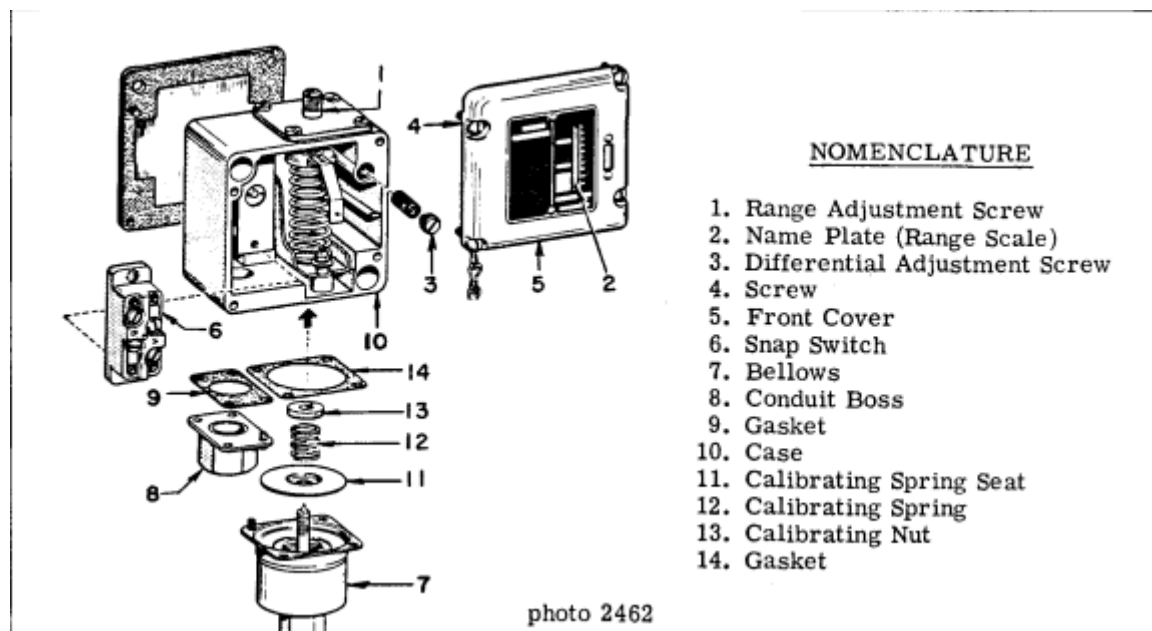

LOW LUBE OIL PRESSURE SWITCH

## DESCRIPTION:

In Diesel loco lubricating oil is stored in the sump located at the bottom of the crankcase. The capacity of the sump is 910 litres in WDM2 and 1260 litres in WDG3A.

The lube oil pump is mounted at the free end of the engine and is driven by the main crankshaft through gears. When the engine starts working the lube oil pump also works. It draws the oil from the sump and delivers it to the lube oil filter, which is located at radiator room. A pressure relief valve is provided in between pump and filter to release the excess pressure and control the discharge pressure at **7.5 Kg/cm<sup>2</sup>** in order to protect the pump.

From the filter, the oil next flows through lube oil cooler where cooling water cools it. A bye-pass valve is fitted between inlet and outlet of the filter. This valve bye passes the lube oil when the difference in pressure between inlet and outlet of filter exceeds **1.4 Kg/cm<sup>2</sup>**. It also bye-pass the lube oil during cold start.

**Note:** In some locos the bypass valve is not provided. In its place a pre lubrication pump driven by motor is provided which will work with battery supply before cranking.

The outlet of the lube oil cooler is connected to lube oil strainer. Before the strainer two connections are taken. One connection is for regulating valve, which is set at **4.2 Kg/cm<sup>2</sup>**. Second connection is to Turbo super charger for lubrication of rotor bearings. The oil then returns to sump.

The oil filtered in the strainer is then enters into the lube oil main header inside the engine block. Three branch pipes are taking off at a point after the strainer.

- i. One pipe for lube oil pressure gauge and OPS available in the cabin.
- ii second pipe to left side auxiliary header.
- iii third pipe to right side auxiliary header.

From Left auxiliary header two more pipe connections are taken to supply lube oil to **Vibration Damper** and **left side camshaft bearing**. From Right auxiliary header one

From Right auxiliary header one branch pipe is taken off and is given to **right side camshaft bearing /OSTA** for lubrication.

From Left/Right auxiliary headers for each cylinder two-branch pipes are taken to lubricate valve lever mechanism and FIP support. At the end of both auxiliary headers connection is given to cam gears for lubrication (Spray nozzle).

### **LUBRICATION TO MAIN BEARINGS:**

The lube oil from the 'Main Header' is taken to the Crankshaft main bearing (9 Nos) through individual pipes called '**S**' pipes. After lubricating the main bearings, through drilled passage inside the crankshaft the oil reaches the crank pins and big end bearings. From there through '**RIFLE DRILLED**' holes in the connecting rod, the oil goes to the piston pin and then goes to the piston crown through the internal holes available in piston called 'Cooling Grooves'. On circulating inside the piston crown the lube oil cools the piston crown since they are exposed to very high heat during combustion.

After cooling the piston crown, the oil drops down. The rotating crankshaft and connecting rod big end splash the oil all over the cylinder liners. Thus the inner surface of the cylinder liners is lubricated and the carbon deposits are washed. The oil control rings evenly spread the splashed oil and then oil scrapper rings during down ward movement of piston scrap oil down. Certain quantity of lube oil is always retained in "**HONEY COMB HOLES**" of cylinder liner for better lubrication. The lube oil falls on base screen is then goes to the sump. The lube oil filter, and strainer are connected to sump by vent pipes so as to carry the Vapour into the sump.

**LUBRICATION OF MAIN BEARING**

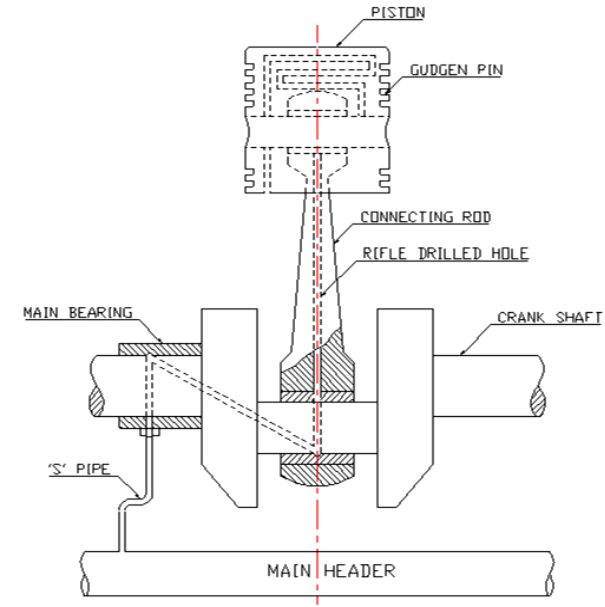

**LUBRICATION OF MAIN BEARINGS**

The schematic of the lube oil system is as below:

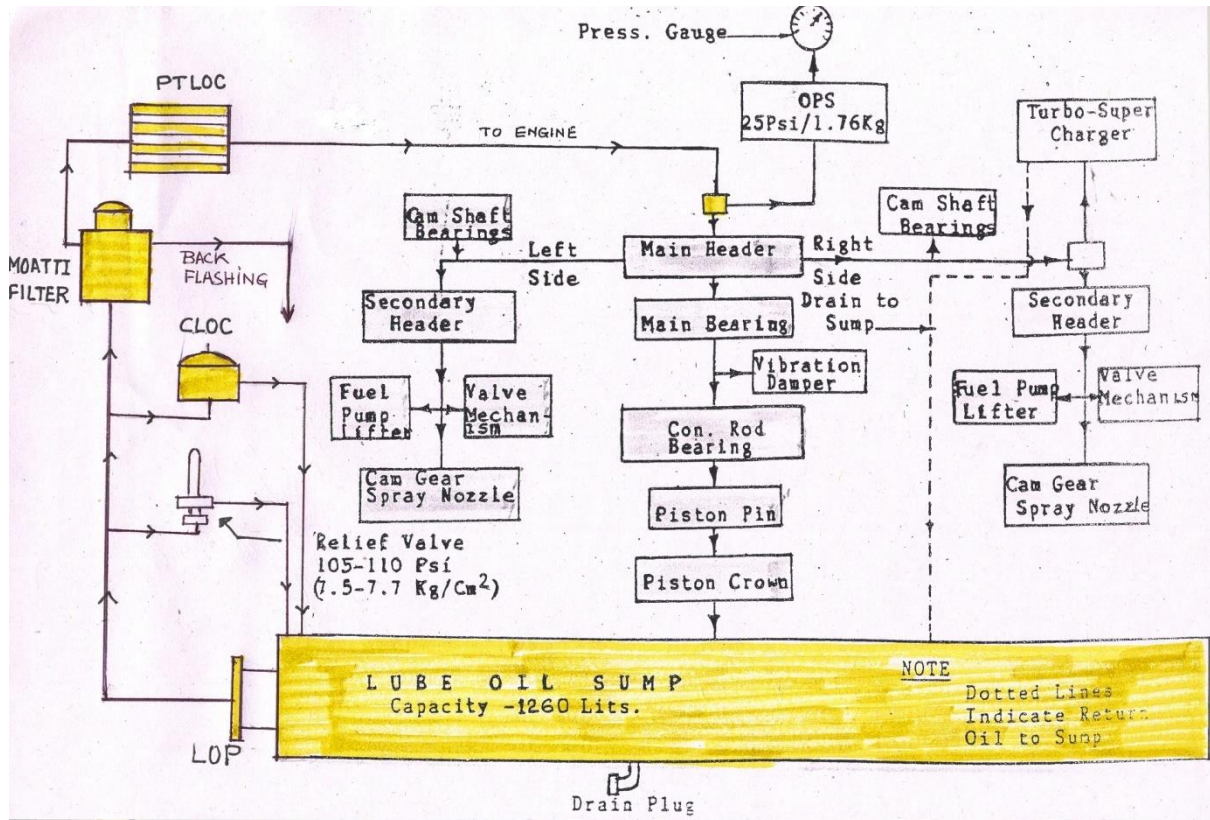

**LUBE OIL SYSTEM (MODIFIED)**

## **LUBRICATION POINTS:**

- FROM MAIN HEADER PIPE
  - All Main bearing
  - Crank pin, Connecting rod big bearing & crank pin journals. further through raffle hole lube oil reach to Gudgeon pin (Piston pin) & bearings
  - From piston pin to piston to piston crown (For cooling the piston)
  - Splash lubrication of Cylinder liner (when oil is returning to the sump after cooling the piston)
  
- FROM SECONDARY HEADER (LEFT SIDE)
  - Cam shaft bearing.
  - V/V lever mechanism & Cam lobe.
  - Cam gear for cam shaft drive.
- FROM SECONDARY HEADER (RIGHT SIDE)
  - Cam shaft bearing.
  - V/V lever mechanism & Cam lobe.
  - Cam gear for cam shaft drive.
- OTHER CONNECTIONS (R/S)
  - To Governor ( From right side secondary header)
  - To TSC(for bearing)
- FROM NEAR STRAINER  
Pressure gauge & OP

## **CRANK CASE EXHAUSTER:**

For the efficient working of the engine and also to maintain certain amount of vacuum in the crank case by expelling the hot oiled vapour (hot fumes) emitting from the oil from the sump, this crank case exhauster is provided. It is driven by an electrical motor, which gets supply from the batteries before cranking and from auxiliary generator after cranking the diesel engine.



## **CRANK CASE EXPLOSION DOORS**

These are provided on the diesel engine crankcase to avoid extensive damage due to positive pressure developed inside engine crankcase. This may happen due to failure of CCEM which when unnoticed by engine crew for a considerably long period and whenever there is a main bearing failure. Whenever the pressure inside the crankcase exceeds a certain limit these doors may open and prevent damage to the engine block.

This is provided in place of one of the inspection doors, one on each side. This opens whenever the pressure inside exceeds a preset value and releases the excess pressure and again closes when the pressure drops down below the spring tension. When the explosion doors open it indicate that a positive pressure is prevailing in the crankcase. The reason may be due to

- a) Failure of any one of the main bearing, big end bearings.
- b) Failure of the crank case exhauster on run not noticed in engine room. In the event of experiencing this engine should be shut down immediately.

## **5.COOLING WATER SYSTEM**

### **COOLING OF HEAT ENGINES**

The components, which are having contact with the exhaust gas, will get hot. The components like pistons and bearing metals would become so hot and thus seizure could occur.

Therefore this heat must be maintained with fairly close limits to achieve maximum power.

Too high the temperature would cause detonation and too cool would make the engine fuel consumption uneconomical.

Our diesel engine is a heavy-duty engine with enormous horse power output, the cooling water system which is employed to maintain the temperature and cool the components like cylinder liners, cylinder heads and turbo super charger is actually a “Circulating water system” assisted by a gear driven water pumps.

In addition to cooling of the above components the cooling water helps to cool the hot lube oil returning to the sump before being sent back to the system.

### **FUNCTIONS OF COOLING WATER SYSTEM**

Cooling water is used in locos for three functions:

1. To absorb the heat from the lube oil and the power pack.
2. To cool the turbo super charger, which get heated on account of exhaust gases.
3. To cool the super charged air in the after cooler.

The heat absorbed by the cooling water will be dissipated through radiators to the atmosphere and the water is again circulated

## COOLING WATER SYSTEM (MODIFIED)

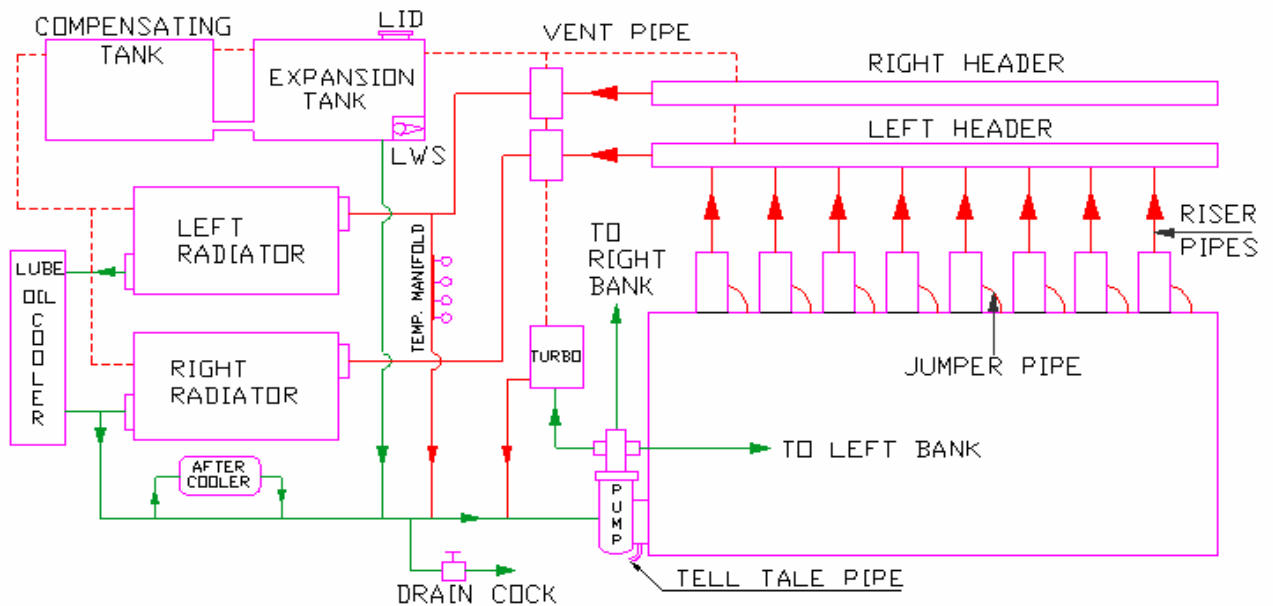

### COOLING WATER SYSTEM

#### **DESCRIPTION:**

In the cooling water system a centrifugal pump gear driven from crankshaft circulates the water. In this system the water is kept full flow in the system and also the expansion tank, which serves as an additional reservoir.

When the engine is working cooled water is drawn by the pump and discharged towards the delivery side into the three-way elbow. Three different connections are taken from three-way elbow.

1. One connection is taken through a flexible water pipe to the turbo super charger. The water enters in the turbo inlet casing at the bottom and circulates in its hollow passage to cool the intermediate casing walls between the blower and turbine end bearings, which are in constant connection with exhaust gases. From the intermediate casing water enters in the turbine casing through four circular interconnecting passages situated 90 degree apart on the periphery of the casing.
2. The second connection from the three-way elbow is taken through a steel pipe to the left bank of the cylinder block.
3. The 3<sup>rd</sup> connection from the three-way elbow is taken to right bank of the cylinder. In both the banks the cooling water enters the engine block and circulates outside the cylinder liners and cools it. Then water is conducted to the individual cylinder heads through water jumper pipes. By flowing into the cavities of cylinder heads, water cools the cylinder heads. From every cylinder heads, water flows to the common water return headers on the left and right sides through individual raiser pipes.

From the water return headers, water is made pass through the “Bubble Collector” before reaching the radiators.

This has done to break the bubbles formed by the water vapour. Various vent pipes are also provided to prevent steam formation in the system.

Right side water return header is connected to the left side radiator.

Left side water return header is connected to the right side radiator.

Water entering the radiators is naturally cooled by atmospheric air, and air drawn by the rotation of radiator fan.

After passing through the tubes of the left radiator water is taken to lube oil cooler. Here water passes through tubes to cool the lube oil, flowing around the water tubes.

From the lube oil cooler water joins with the right side radiator outlet pipe and flows towards the suction side of the water pump.

From the out let of right radiator a connection is taken to after cooler where water flows through the tubes around which super charge air flows around and gets cooled.

From the after cooler, the water joins to the suction pipe.

The water circulation is repeated again and again as described above.

Two pipes interconnect the expansion tanks that are provided on either side of the radiator compartment. The water in the expansion tank is utilized to supplement the water loss during circulation due to the evaporation or leak. An important safety device is provided in the expansion tank. This is called **Low Water Switch (LWS)**. This is connected to the expansion tank to shut down the engine whenever the water level falls low. The capacity of the cooling water system is **1210 liters**.

## **COMPONENTS IN COOLING WATER SYSTEM**

### **EXPANSION TANK:**

This is located at the top most level of the system and this serves as a reserve tank. An auxiliary tank is also provided above the radiator room. Both the tanks are interconnected .To indicate the water level a gauge is provided inside the radiator room on the right side of head light. While taking over charge water level should be above the half mark of the gauge. The capacity of the cooling water system is 1210 litres. Expansion tank and auxiliary tank are supplementing the loss in the system. A pipe is connected from the expansion tank to the system on the suction line.

An overflow pipe is provided in the expansion tank. In some locos the tank will be having a lid with holes for venting water vapour and thus avoids development of pressure inside tank. If not due to the pressure, water may siphon off from the tank through over flow pipe. Due to any reason if the temperature goes high the water level will go at low as described above. In some locos a pressure cap is provided in place of lid which will operate and release excess pressure in expansion tank. This is provided to avoid complete siphoning of water. Expansion tank is connected with

various vent pipes of the cooling water system i.e. after cooler, turbo super charger, bubble collectors, lube oil cooler and both side radiators for venting the steam.

**Note:** - Distilled water or Demineralised water is used in cooling water system with any one of the following chemical compounds.

Indion-1344 –8.2 kg/loco

Nalco-2100- 36 litres/loco

XGT –120 litres/loco

### **LOW WATER SWITCH:**

This is an important safety device provided to protect the engine from the damages caused due to lack of cooling water. This will shut down the engine when the water level falls down 1” level from the bottom of expansion tank.

A connection pipe is taken from the expansion tank to LWS float chamber, with a 3 way cut out cock. This cock is provided to facilitate testing of LWS without draining the water from the system. When the water level goes down the float in the chamber drops and movable contact from the other end of the fulcrum is lifted which will make contact with the electrical sources. This will send signals to the governor to shut down the engine.

Normally LWS COC must be in open position i.e. to connect the tank and the float chamber. While testing the LWS this COC is to be closed. In this position water flow from the expansion tank stops and water in the float chamber drains out which will operate the switch.

Now a day's electronic water level indicator is provided in the cab. This is having 3 LEDs. 1) Green which indicates water is full. 2) Yellow which indicates water is half. 3) Red which indicates water is to be added. It is also provided with emergency switch for by passing LWS. Whenever LWS malfunctions this switch has to be operated after ensuring sufficient water level.

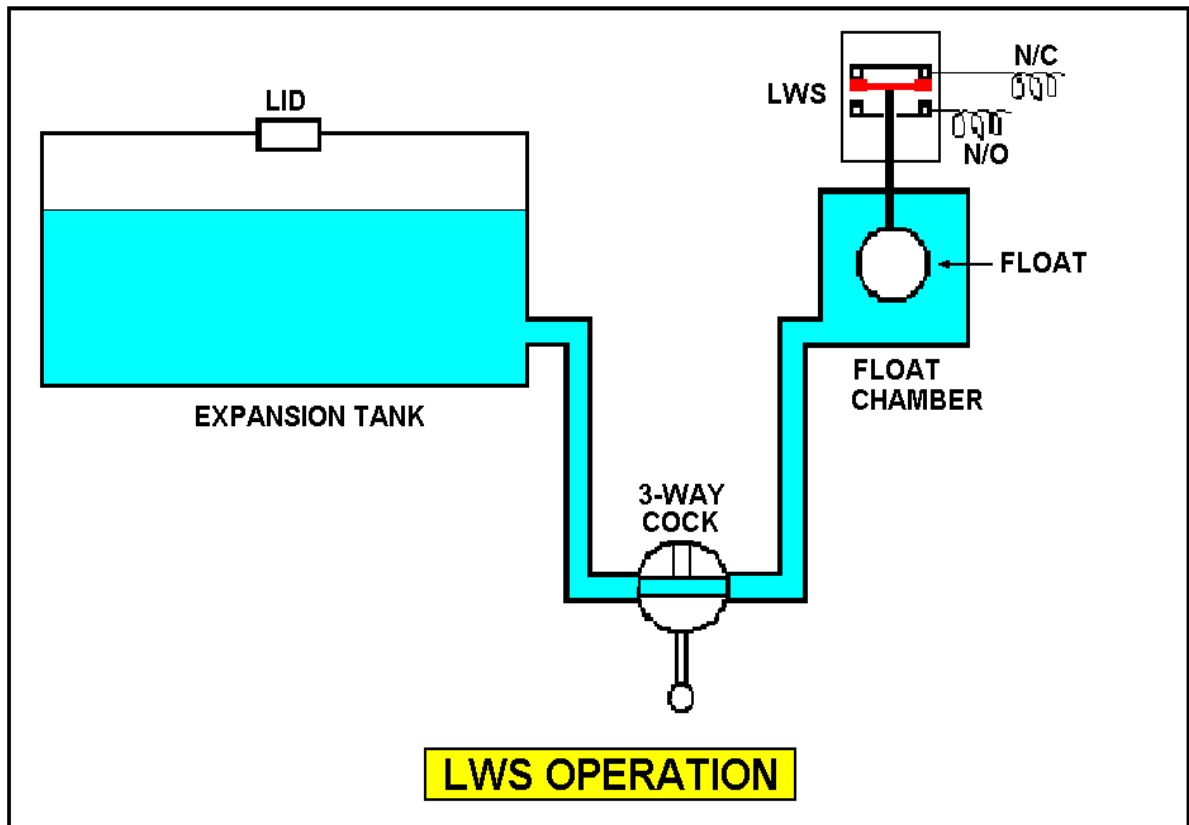

### TEMPERATURE CONTROL DEVICE:

Cooling water absorbs heat from components and so become hot, and it must be cooled before being sent back to the system. Water from the engine block is taken to the radiators and cooled by air, when air passes through the radiators.

Whenever temperature of the water increases, the cooling process in the radiators has to be intensified. For this a radiator fan is provided which is driven by **EDDY CURRENT CLUTCH**. When temperature rises to  $68^{\circ}\text{C}$  thermostat switch no 1 (TS1) gets energised through a sensing element and it operates R1 contactor located in the control compartment. Now a certain amount **6-6.5 amps**) is supplied to operate **ECC**.

## **EDDY CURRENT CLUTCH (ECC) ASSEMBLY:**

This is provided in the radiator room to start and stop radiator fan according to water temperature. ECC Unit is consisting of 2 portions

1. Outer Drum
2. Inner Drum

The outer drum is directly connected to the engine extension shaft and will be rotating continuously as long as engine is working. The inner drum is connected to the radiator fan through a right angle gear unit. The inner drum has an ECC coil provided in between a set of spiders.

When there is no supply in the coil of the inner drum, the fan does not work. When water temperature reaches 68<sup>0</sup> Celsius TS1 operates, R1 contactor picks up and auxiliary generator current is supplied to ECC coil. So the outer drum and the inner drum will be magnetically clutched and radiator fan starts working at minimum speed. That is the speed will be around 70% of the engine crankshaft speed. TS1 gets reenergized and R1 contactor will drop when water temperature falls down to 66<sup>0</sup> C due to which radiator fan stops working.

If the water temperature further rises to 74<sup>0</sup> C in spite of the radiator working at minimum speed, another switch TS2 will operate, R2 contactor picks up. This will supply more current to ECC coil (**12.5 amps**) and so the radiator fan will work at high speed, the speed of the radiator fan will be around 120 % of the engine speed. TS2 will get de-energised to drop R2 contactor when water temperature falls down to 72<sup>0</sup> C due to which radiator fan will work at minimum speed.

In both the above cases the principle is evacuating the air inside the radiator room and thereby creating partial vacuum, so outside air is drawn through radiators to bring down the temperature. When the cooled air contacts with radiator tubes, hot water passing through the radiators gets cooled. The hot air is blown out to the atmosphere by the radiator fan.

**NOTE:** 1. After starting the diesel engine, the engine speed should not be raised till the water temperature level attains 49<sup>0</sup> C.



## EDDY CURRENT CLUTCH

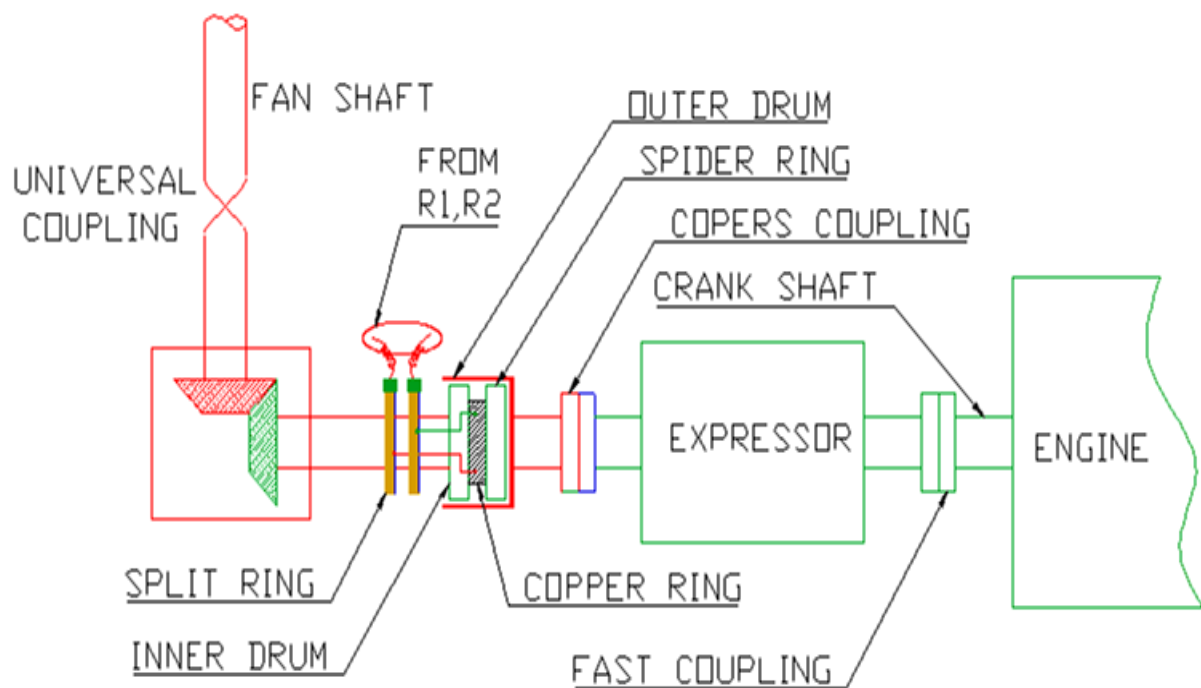

### HOT ENGINE ALARM:

When the loco is continuously working for longer period, at full load condition i.e. climbing a steep gradient hauling full load of the section with highest notch position and the atmospheric temperature is also high, the engine cooling water temperature will still go up in spite of the fan working at full speed.

When the temperature reaches  $85^{\circ}\text{C}$  ETS will get energised and an alarm will sound in the cab and red lamp will glow in both control stands. These audible and

visible indications given by the signal relay (SR). This is called “HOT ENGINE ALARM”. When this is heard the Loco pilot is warned that the engine condition is very hot. On hearing this alarm the Loco pilot shall bring the throttle to idle and check for causes. The observations made by the Loco pilot during his examinations for experiencing hot engine alarm, must be recorded by the Loco pilot in the loco repair book. If radiator fan found working he must do fast air pumping. If section is not favourable ease the throttle and try to clear the section in lower notches and then do fast air pumping. When the temperature goes below 83<sup>0</sup> C the hot engine alarm will be stopped and the Loco pilot can resume normal working.

### **Faster Air Pumping:**

When the Loco pilot wants to bring down the engine temperature quickly faster air pumping has to be done. The procedure is as follows.

1. Keep the REVERSER in neutral (only in stationary locos)
2. Keep GF in off position.
3. Keep ECS in run position.
4. Then raise the throttle to 5<sup>th</sup> notch

The engine speed will rise without loading of main generator i.e. without burning more fuel. When the fuel supply is reduced and the engine is working at high rpm, in turn the water pump and radiator fan will work at high speed. So the temperature will come down very quickly. When the water temperature falls to normal limit engine can be loaded again.

**Reasons For Repeated Hot Engine Alarm:**

REASONS	REMEDIES
<p>a) Radiator room door opened.</p> <p>b) Radiator fan not working</p> <p style="padding-left: 40px;">i) TSI/R1 Defective</p> <p style="padding-left: 40px;">ii) TS2/R2 Defective</p> <p style="padding-left: 40px;">iii) Wire connection cut</p> <p style="padding-left: 40px;">iv) Carbon brushes worn out.</p> <p style="padding-left: 40px;">v) ECC coil defect</p> <p style="padding-left: 40px;">vi) Right angle gear unit/ Universal coupling defect</p> <p>c) Expansion tank</p> <p style="padding-left: 40px;">i) In sufficient water level</p> <p style="padding-left: 40px;">ii) Lube Oil contamination in water</p> <p style="padding-left: 80px;">iii) No circulation of water due to Pump defect</p> <p>d) Radiators dirty and hence air passage blocked</p> <p>e) Water passage blocked due to scale formation.</p> <p>f) ETS malfunctions</p>	<p>Close the door and secure it</p> <p>Switch ON ERF switch.</p> <p>Switch ON ERF switch.</p> <p>Secure it</p> <p>Check carbon brushes and renew it.</p> <p>Inform shed</p> <p>Inform shed</p> <p>Add water duly consulting shed</p> <p>Inform shed</p> <p>Inform shed</p> <p>Clean with compressed air.</p> <p>Inform shed</p> <p>Check water temperature gauge if found less inform shed.</p>

## CENTRIFUGAL WATER PUMP:

The water pump is situated on the left side free end of the engine. The pump circulates water in the cooling system. The pump is getting its drive from the diesel engine crankshaft through a step gear. The gear ratio is 79:46 (79 drive shaft and 46 driven shaft). The capacity of water pump delivery is 2457 Litres per minute, at a speed of **1720 RPM**. The lifting capacity is 3 feet. The pressure developed by the pump will be 30 PSI at a temperature of 180 °

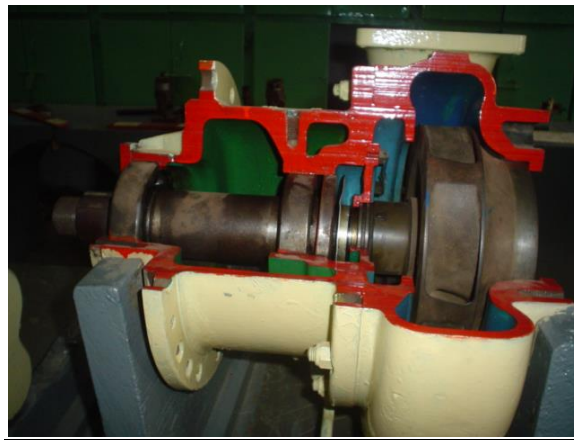

CENTRIFUGAL WATER PUMP

## TELL TALE PIPE:

Water seals and oil seals are provided in the water pump and sometimes they may develop defects. So the visual indication is given to the Loco pilot through a pipe fitted on the water pump. This is called 'Tell Tale Pipe'. If water is seen coming through this pipe, it indicates the defective water seal and similarly the oil seal.

1. Whenever water is leaking through TTP. Loco should not be taken overcharge from shed.
2. If this is noticed enroute contact shed, the loco can be worked onwards carefully watching the water level.
3. While taking over charge in enroute normally 8 drops per minute is allowed.
4. If the leakage is very heavy, loco should not be worked further.

5. When oil leak is noticed from shed, the shift supervisor should be informed for rectification or certification.
6. Oil leak noticed enroute inform shed and work onwards duly checking the oil level in the sump and make the entry in the repair book.

**NOTE:** Under any circumstances TTP should not be plugged.

### **IMPORTANT CHECKS TO BE MADE IN COOLING WATER SYSTEM:**

1. Water level in the expansion tank.
2. Water main drain cock is tightly closed. This is located in the Expresser room. If it is not closed properly water may run down on run causing hot engine alarm. If level of water goes too low the engine may shutdown by the action of LWS.
3. LWS COC must be open. If it is not in proper open position or if closed, the engine will be cranked but will not get fired at the time of starting.
4. Whirling action of the water in the expansion tank must be ensured after cranking the loco. By this the proper working of water pump is ensured.
5. Ensure the Expansion tank lid or pressure cap is secured properly.
6. No oil or water leak through TTP.
7. There should be no leak in the system, especially the jumper pipe joints, water raiser pipes, header pipes and the radiators while TOC.
8. If any one of the vent pipes is leaking and it is notices on run, it must be bandaged. On no account vent pipes are to be dummied.
9. Before leaving shed, among the 10 tests, the radiator fan test must be conducted positively.
10. It is always better to rotate the radiator fan manually before cranking. This is done to check the free operation of the fan ensuring the condition of right angle gear unit and universal coupling.

## **OPERATING WATER LEVEL:**

The operating water level indicator indicate minimum and maximum water level with the engine running or stopped. The water level mark should not be permitted to go below the applicable “low” water level mark. Progressive lowering of the water in the gauge glass indicates a water leak in the cooling system, and should be reported.

The coolant is circulated through the engine to transfer heat from the engine components to the radiators. **Engine coolant** is composed of **water, corrosion inhibitor**, and when considered necessary, **antifreeze**.

## **COOLANT:**

To be suitable for use in EMD engines, a coolant must meet four Basic requirements:

- Adequately transfer heat energy through the cooling system
- Not form scale or sludge deposits
- Prevent corrosion inside the cooling system
- Can't deteriorate seals or gaskets in the cooling system

## **WATER:**

The water in some areas contains elements such as excessive solids, hardness salts, or corrosive elements such as chlorides that make it unsuitable for use in the cooling systems of EMD engines. Water from these sources should be processed by **softening, de-ionizing, or distillation** to make it suitable for cooling system use.

## **6.SHED LAYOUT**

### **MAKING OF LAY OUT OF 100 LOCO DIESEL SHED AND FACILITIES**

- A uni-directional movement of locomotive in the shed is preferable.
- Separate entrance and exit points should be provided to avoid bottlenecks.
- The layout should permit a locomotive to skip stage of servicing without hampering the Flow of Other locomotives.
- The shed should have covered accommodation in its repair area for about 25-30% of the fleet Homed. The yard of the maintenance shed should be able to hold at a time about 50% of the total holding of the shed.
- Each line in the covered repair area of the shed should be able to hold 3 locomotives. The layout should provide for possibility of expansion width-wise i.e. by providing more lines side by side.

### **FOLLOWING POINT SHOULD BE CONSIDERED WHILE CONSTRUCTING A SHED**

- ✓ The shed should have three level working floor arrangements.
- ✓ This facilitates simultaneous and expeditious maintenance service as well as repairs.
- ✓ The flooring should be such that spilt oil can be easily removed.
- ✓ Pits should have convex flooring and efficient drainage.
- ✓ Flooring in heavily lifting bays should be strengthened.
- ✓ Platforms and ramps should be provided
- ✓ Minimize dust nuisance in working area.
- ✓ Uniform roof height
- ✓ Protect personnel working all elevated platform falling down.

- ✓ Roof extractors should be provided to expel harmful diesel fumes.
- ✓ covered space as under should be provided to take in a part of the

The shed layout should permit future expansion of the covered area in a manner to accommodate more lines under the covered area. The expansion along the length of running lines is not advisable.

### **THE SHED BUILDINGS SHOULD NORMALLY INCLUDE**

1. Injection room, Battery room, (with exhauster)
2. Break test room,
3. Welding booth,
4. Machine room,
5. Blacksmith shop and coppersmith shop.
6. Break test equipment room, (air-conditioned)
7. Filters' benches,
8. Lubricants store with pump house, (dust proof)
9. Stores,
10. Tool stores,
11. Distillation plant and boiler room, or other water treatment plant.
12. Laboratory,
13. Lockers and washing room,
14. Supervisors' room,
15. Shed officers' room,
16. Library-cum-lecturer room,
17. Lube oil filter plant,
18. Water load box computerized & dust proof,
19. ROC room.



## FACILITES LIFTING AND MATERIAL HANDING

- Over head crane of suitable capacity should be provided to **serve the heavy repair** –way the free space, part of the machine shops and the store For lifting of smaller locomotive, heavy hydraulic jacks could be used Battery moving trolley car should be used for transportation of scrap For lifting heavier locomotives, electrically operated heavy lifting jacks
- **Shed Lighting:** Lighting inside the shed with fluorescent tube is desirable .illumination at platform and floor level of the minimum of 20 foot candles should be provided. Bulk head fitting for direct lighting of the under gear. Plug point at 24 volt should be made available at all levels in the pits. Yard lighting should result in an even illumination of 3-4 foot candles. Fuel Supplies Installation-For storage of fuel oil tank should be provided above ground level. The tank should be approachable by road as well. For day to day fueling and decanting. An electric pump must be provided .total storage capacity provided should hold a minimum of 10 day consumption. The delivery hose should be installed such that the nozzle does not touch the ground when not in use, and is suitably protected from rain and dust.
- **Sanding:** Proper storage facilities for sand should be provided to keep the sand dry. In places where rainfall is heavy, sand drying facilities should also be provided. Arrangement should be made for sand to be fed to locomotives by gravity.
- **Washing:** A proper washing apron should be provided for washing of locomotives.

- **Shed storage:** The storage room should be preferably at platform level and provided with a rail siding to help direct loading and unloading of storage wagons. The storage should have an approach by road as well. Suitable to avoid damage to components. Since the maintenance of diesel locos requires a ready stock of a large number of spares. Generous accommodation should be provided for the storage.
- **Battery room:** A separate battery room should be provided preferably at platform level. Care should be taken to provide exhausters to exhaust harmful fumes etc. from the battery room. Battery charging plant should be installed with points available beside the bits to allow direct Charging of batteries while in position on the locomotives.
- **Compressed air:** Supply of compressed air should be arranged care being taken to install the air compressor in a place where minimum disturbance and vibration to the surrounding are caused. Compressed air points should be provided near each servicing berth.
- **Lubricating oils:** Lubricating oil storage tanks should be located at convenient sites to make lubricating oil readily available at the pits. Facilities for drainage of engine lubricating oil from locomotives should be to enable easy collection and removal of engine lubricating oil without spilling and dirtying the service pits. The yard should be of sufficiently generous dimensions to permit free mobility for normal working and to meet with emergencies, and it should provide adequate holding capacity for at least 50% of the fleet homed in that shed.

- **Fire Fighting:** Adequate safety measures must be adopted against fire hazards in the shed. Since large volumes of petroleum products are handled, special precautions are necessary. Fire fighting equipment such as hydrants, hoses, extinguishers and for alarm boxes etc. should be conspicuously visible both at day and at night.
- **Training School:**-For proper maintenance of the sophisticated equipment on diesel locomotives, the work force has to be adequately trained.
- **Laboratories:** - For following testing
  - ✓ Spectrograph for lube oil testing.
  - ✓ Magna flux testing machine.
  - ✓ Rubber tensile testing machine.
  - ✓ Zygo testing machine.
  - ✓ Oscilloscope.
  - ✓ Ultra sonic testing machine
- **M & P:** - **Following M&P is required**
  - ✓ E.O.T cranes 40 tons & 10 Tons.
  - ✓ Whiting Jacks.
  - ✓ Tram beam 3 Ton cranes.
  - ✓ Pillar cranes with 1.5/1ton hoists -16
  - ✓ Forklift truck (2T)-2.
  - ✓ Platform Truck (2T)-5.
  - ✓ Pick up van-2.
  - ✓ Truck 3 tons-1.
  - ✓ Monorail with hoist for battery room, heavy switches gear and piston assembly.

- ✓ Hoist for Governor, heavy switch gear.
- ✓ Floor wheel lathe.
- ✓ Dynamic balancing machine
- ✓ Water                      and                      Grid                      load                      Box.

## 7.UNDER TRUCK

1. **Hand brake**: Hand brake Is fitted in driver cabin and works as hand pump to lock the wheel R1.
2. **Cattle guard**: It is fitted with rear & front at the end of locomotive. it is bolted with chassis of the engine with height 7.5” approximately from rail level. It is also welded/ bolted with three supports, two at the sides of the cattle guard and one is middle of the cattle guard. Cattle guard provides the protection to air brake pipes from infringement like cattle run over.
3. **Rail guard**: It is fitted on cattle guard. This protecting any obstacle faults on the rail. Rail guard bolted with rail guard with height 4” approximately from rail level.
4. **Stay plate**: Stay plate is fitted on every bottom of the on the bogie frame in each hub, two number of stay plate fitted with bolts and leveling washer also provided to overcome problem with unscrew the bolts stay plate protects the axle to axle while on locomotive, force applied on the axle, so axle may come out from the hub may from the derailment / accident
5. **Gear case bolts**: Gear case covered bull gear and pinion as a housing. Gear case mounted with two bolts and jointing with four bolts. These bolts given protection to gear case housing, in which servo coat filled. In case of bolt loosened or broken, Hanging/uncoupled housing works as infringement
6. **Gear case U clamp**: It protect the bolts of safety clamp, Which are fitted with spring chair and safety clamp

7. **Brake hanger sling**: Brake hanger sling fitted between brake hanger and tie bar. it gives support to tie bar to not uncouple in case of brake shoe bolt broken.
8. **C.B.C. pin**: It's retained the retaining plate of center buffer coupler and holds the CBC.
9. **Wages**: These wages are made of wood and fitted on track under wheel to give protection against rolling of wheels.
10. **L-rod**: To operate the BKT/ Reverser manually, when any reason they are not operating automatically or stick up.
11. **Equalizing beam tie bolt**: Two nos. of bolts fitted with spring chair and safety bracket for each set of equalizing beam. Equalizing beam tie bolt hold the spring chair.
12. **Equalizing beam U clamp**: Equalizing beam clamp protect the bolts of safety clamp.
13. **Equalizing beam bolt split pin**: One split pin is fitted with each bolt of the equalizing beam It gives protection to equalizing beam bolt to not uncouple.

## 8.HHP LOCOS

### The main characteristics of GT46 MAC, GM Loco

AC-AC locomotives hitherto manufactured by M/s.General Motors company/American GT 46MAC the axle load is around 20.5 tSSSS

### GT46MAC is provided with the following special features-

#### 1. Performance Specifications

- 4000 TCV locomotive.
- Higher tractive and braking effort capability – 540 KN starting TE and 270 KN braking Effort.
- 11% improvement in fuel efficiency over existing WDM2 locos.

#### 2. Performance Impact

- The GT46MAC provides unit reduction, fuel savings and additional revenue tonnage capability.
- Operation of fewer units results in significant maintenance and operating savings

#### 3. Reliability and Serviceability

- 90-day maintenance intervals
- AC motors double traction motor life

- No running maintenance required on traction motors, No brushes, commutator, nor rotor Insulation, No flashovers/ground relays
- Bogie Inverter Control High level of reliability with fewer parts
- 1.6 million kilometre ( 1 million mile) overhaul with HTSC bogie.
- 6 year engine overhaul period.

**4. Computer Control, a 32 BIT computer control for locomotive controls having following features -**

- Trouble Shooting and Self-Diagnostics.
- Alpha Numeric display.
- Archive memory and Data logging.
- Radar based super series Wheel Slip/Slide Control System.

**5. Engine**

- 4,000 TCV, 16-710G3B
- High efficiency turbocharger
- Unit fuel injectors which eliminate the problematic HP tube.
- Low emissions
- Laser hardened cylinder liners.
- Inconel valves and Hydraulic valve adjuster.
- Durable crankcase and piston structure.



## 6. AC Traction Technology

- Simple, robust motor design
- Higher efficiency-lower temperatures
- Doubles motor overhaul interval
- Utilizes bogie –controlled AC traction inverters for higher inherent reliability
- All weather adhesion of 32%
- High adhesion and Tractive effort
- Maintenance-free traction motors
- No limitation of minimum continuous speed
- High reliability and availability.
- Lower rolling resistance and higher energy efficiency

## 7. HTSC Bogie-Basic

- No wearing surfaces extent bogies overhaul intervals to 1.6 million kilometres (one million miles).
- Dual high adhesion and high speed.
- Available gear ratios for heavy haul and passenger operation.
- Reduced wear of components extends bogie overhaul intervals to 1.6 million kilometres (one million miles)

## **8. Improved mechanical systems, the notable being-**

- Microprocessor based engine cooling system
- High lube oil sump capacity
- Self-cleaning inertial type primary filter
- Efficient secondary air filtration

## **9. Improved Miscellaneous Electrical Systems:**

- Wide range dynamic brakes effective down to near standstill
- Maintenance-free roller suspension bearings having lower rolling resistance
- Efficient filtration for electronic cabinet.

## **10. Cab Features**

- Desk style control console
- Air operated windshield wipers
- Multi-resettable vigilance controls (optional)

## **11. Air System**

- Knorr CCB Electronic Air Brake System
- Direct drive WLN air compressor

## 12. Safety Aspects

- Increased crashworthiness requirements
- Cab design and overall car body configuration provides improved visibility
- Anti-climber available

## **CHARGE AIR SYSTEM OF HHP LOCOS**

Diesel Engine in WDG4/WDP4 locomotive is a super charged fuel-efficient and two stroke engines. Since the locomotive is provided with two-stroke engine, the inlet air requirement for proper combustion of the fuel is high. To fulfil the requirement of the engine a special turbo super charger is provided in this locomotive to supply required quantum of air in each notch according to load and speed condition.

### **REQUIREMENT OF AIR SUPER CHARGING SYSTEM**

Diesel engine Uses chemical energy to generate Heat energy. This heat energy will be later converted into Mechanical energy. To produce the heat energy, fuel is burned inside the combustion chamber. For efficient burning more oxygen is required. For supplying more fuel, SUPER CHARGING is required. In this process air is introduced into the engine cylinder at a density more than ambient. This will produce more power than a naturally aspirated engine for the same bore and stroke dimension. Super charging causes better scavenging also.

### **ADVANTAGES OF SUPER CHARGING**

- Better cooling of components.
- Saves them from failure due to thermal stresses.
- Enhances the service life.
- Better fuel efficiency.
- Power to weight ratio is much more.

## COMPONENTS OF CHARGE AIR SYSTEM

Air intake system is dividing in the following steps.

1. Inertial air intake/cyclonic type air intake filters
2. Clean air chamber
3. Baggy type engine air intake secondary filters.
4. Turbo super charger.
5. After coolers.
6. Air boxes.

### 1. **Cyclonic Filters:**

Air from the atmosphere is taken into cyclonic filters provided on both sides of the locomotive outside the clean air chamber. AC motor driven dustbin blower creates partial vacuum in clean air chamber and draws air from the atmosphere. The dust, dirt and suspended particles in the drawn air will be expelled out by centrifugal action created by inertial/cyclonic filters. Pure filtered air will be taken inside clean air chamber and dustbin blower will pump the dust and dirt out down the locomotive.

### 2. **Clean air chamber;**

Air from the clean air chamber is further utilized for the following.

- a) The diesel engine through secondary air intake baggy filters.
- b) For cooling of all six traction motors and main alternator by TM blower and for the air compressor air intake.
- c) Air is taken to cool both the TCC's through TCC electronic blower.

- d) Compressed air is taken to pressurize electrical control cabinet to protect components from entry of dust.

3. **Baggy Type Engine Air intake Filter:**

Air from the clean air chamber is drawn by turbo through engine mounted baggy type secondary air intake filters, which further filters the intake air for the engine, and clean air is pumped to engine air boxes by turbo charger.

4. **Turbo Charger:**

The turbo charger is basically provided to increase the engine horsepower output to its maximum extent and provide better fuel economy. The turbo charger provided in this locomotive is of a special type single stage turbine, which maintains constant air to fuel ratio throughout the engine operation.

At the beginning stage turbo is directly driven by the engine through a gear train approximately with gear ratio of 1:18 and after reaching 6<sup>th</sup> notch in load, turbo mechanical drive will be disengaged by overriding clutch since the energy in exhaust gases from the engine is sufficient to drive the turbo. Air then is compressed by the turbo impeller and is directed to after coolers through diffuser casing.

5. **After Coolers:**

Two after coolers are provided in this locomotive one on either bank of engine. After cooler is water-cooled type to take out heat from the compressed engine intake air to supply high dense air for complete combustion of the fuel in combustion chamber. The water for after cooler is taken from the engine cooling watersystem.

## 6. **Air Boxes:**

Air boxes are provided one on each bank of the engine to supply the high dense clean air for the engine requirement. Air from the air box is taken into individual cylinder through cylinder liner port openings during suction stroke when piston uncovers the inlet force.

The huge air box on either side of the engine helps to cool the cylinder continuously since the compressed and after cooled air is surrounded the cylinders. A common drain from both bank air boxes is provided down in between two trucks, which drains the water or oil, which is collected in the air boxes. Drivers or crew are required to see this air box drain pipe and report to shed if they found water traces which is the symptom of water leakage in the air intake system.

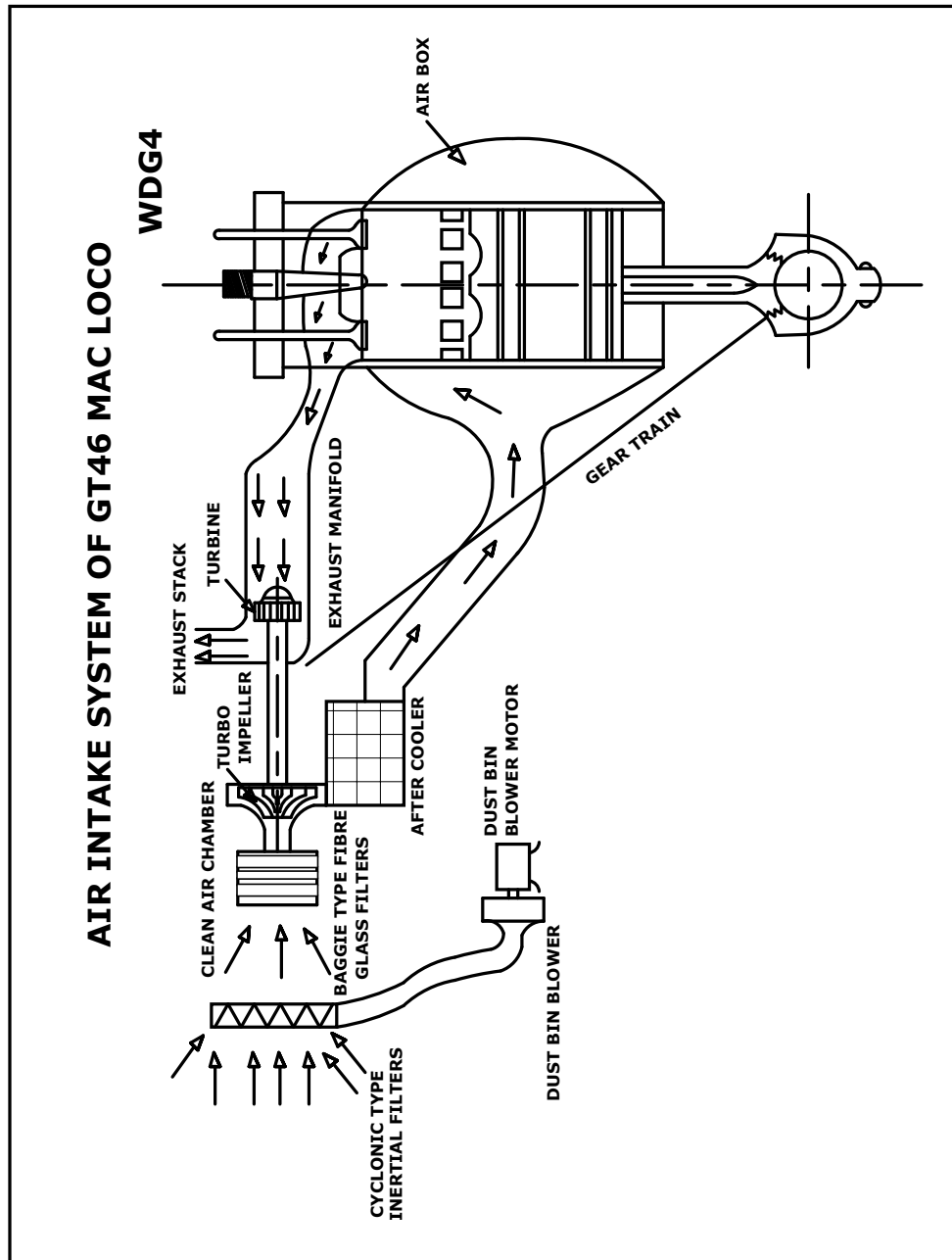

**CHARGE AIR SYSTEM OF ALCO LOCOS**



## COMPONENTS OF CHARGE AIR SYSTEM

- Air intake filter
- Turbo Charger Assembly
  - ALCO 720
  - ABB
  - GE
- After cooler
- Air manifold
- Exhaust manifold

## MAIN COMPONENTS OF TURBOCHARGER

- **Gas Inlet Casing**: It is made of CH20 stainless steel which is highly heat resistant. The function of this casing is to take hot gases from the exhaust manifold & pass them through the nozzle ring.
- **Turbine Casing**: It is made of alloy CI or fabricated. It is fitted in between inlet & intermediate casing. This casing is water cooled.
- **Intermediate Casing**: It is made of alloy CI or fabricated like turbine casing. It is placed between turbine & intermediate casing. This casing is also water cooled. It separates exhaust & air side.
- **Blower Housing Assembly**: Air enters through the blower inlet axially & is discharged radially to the vane diffuser.

- **Rotor Assembly:** It contains rotor shaft, rotor blade, inducer etc. It is dynamically balanced component as it has a very high rotational speed



### ROTOR ASSEMBLY

- **Diffuser:**
  - It is fixed on the main casing at the back side of impeller assembly.
  - Velocity of air is diffused to increase its pressure.
  - Should be checked for worn out partitions.



DIFFUSER

## **WORKING OF TURBOCHARGER**

Turbo-charger is fitted at the end of exhaust manifold. Exhaust gas from all the cylinders accumulates in the common exhaust manifold. The gas under pressure enters the turbo-charger and passes through the fixed nozzle ring. Then exhaust gases are directed on the turbine blades at increased pressure and at the most suitable angle to achieve rotary motion of the turbine. After rotating the turbine, the exhaust gas goes out to the atmosphere through the exhaust chimney. The turbine has a centrifugal blower mounted at the other end of the same shaft. The rotation of the turbine drives the blower at the same speed. The blower connected to the atmosphere through a set of filters sucks air from atmosphere and delivers at higher velocity. Air then passes through the diffuser inside the turbo-supercharger where the velocity is diffused to increase the pressure of air. Due to compression of air, heat develops & the density of air decreases. The air is then passed through an after cooler having two separate passages where atmospheric air at ambient temperature is passed through adjacent passage. The heat in the air is thus transferred to the

cooling air and air regains its lost density. From the after cooler air goes to a common inlet manifold connected to each cylinder head. The high RPM of rotor assembly creates sufficient air pressure in the air intake manifold.

## **LUBRICATING, COOLING AND AIR CUSHIONING**

### **Lubricating System:**

One branch line from the lubricating system of the engine is connected to the turbo- supercharger. Oil from the lube oils system circulated through the turbo- supercharger for lubrication of its bearings. After the lubrication is over, the oil returns back to the lube oil system through a return pipe. Oil seals are provided on both the turbine and blower ends of the bearings to prevent oil leakage to the blower or the turbine housing.

### **Cooling System:**

The cooling system is integral to the water cooling system of the engine. Circulation of water takes place through the intermediate casing and the turbine casing, which are in contact with hot exhaust gases. The cooling water after being circulated through the turbo- supercharger returns back again to the cooling system of the locomotive.

### **Air Cushioning:**

There is an arrangement for air cushioning between the rotor disc and the intermediate casing face to reduce thrust load on the thrust face of the bearing which also solve the following purposes.

- It prevents hot gases from coming in contact with the lube oil.
- It prevents leakage of lube oil through oil seals.
- It cools the hot turbine disc.

Pressurized air from the blower casing is taken through a pipe inserted in the turbo-supercharger to the space between the rotor disc and the intermediate casing. It serves the purpose as described above.

### **AFTER COOLER**

It is a simple radiator, which cools the air to increase its density. Scales formation on the tubes, both internally and externally, or choking of the tubes can reduce heat transfer capacity. This can also reduce the flow of air through it. This reduces the efficiency of the diesel engine. This is evident from black exhaust smoke emissions and a fall in booster pressure.

### **WIRE MESH CAR BODY FILTER SYSTEM**

Initially wire mesh type dry or oil soaked filters were used to clean the air being sucked by the turbo inducer by absorbing the dirt, dust etc in the atmospheric air so that the effectiveness as well as service life of after cooler gets increased. Smaller dust particles could not be filtered leading to less service life of after cooler and as such frequent choking and attention (quarterly in some areas)

### **OIL BATH FILTRATION SYSTEM**

Wire mesh car body filter system were later on replaced by oil bath wire mesh filters where the air was made to pass through oil before entering the turbo inducer leaving all the dirt, dust etc in the oil itself. Some part of the oil was sucked by turbo inducer slowly, leading to shortage of oil & premature choking of after cooler.

## **DEEP DESIGN TYPE GLASS WOOL FILTRATION SYSTEM**

Here two stage filtration is done using primary filter (swirling action caused by plastic volutes added by suction power of Exhauster motor to extract solid dust, dirt etc) and secondary Glass wool filter media (Deep design type to filter fine impurities in the sucked air). This filtration system has less service life of secondary filters due to frequent choking requiring frequent attention (in some areas 4 months against 8 months life).

## **TESTING OF CHARGE AIR SYSTEM**

### **Roller clutch test:**

1. Idle engine until normal operating temperature is reached. (If engine cannot be started, remove rubber boot from turbo inlet and verify that the impeller locks up when attempting to turn in a clockwise direction by hand. If this does not occur, either the clutch has completely failed or a planetary gear train failure has occurred. Refer to paragraph Additional External Inspections.)
2. With engine warmed-up, push injector control linkage lever inward, increasing engine speed to approximately 700 RPM.
3. Pull injector control linkage lever out completely to "No Fuel" position, overriding the engine governor. (At this time, the clutch will disengage, allowing the turbine to spin free of the gear drive.)
4. As the engine begins to stall, push the injector linkage lever in once again, providing more fuel, which should increase engine speed. The decelerating turbine wheel will "meet" the accelerating engine gear train and the roller

clutch should engage, providing sufficient air for continued engine speed increase.

If the clutch fails to engage, the injector rack linkage will move toward “full fuel” position, black smoke will emit from the exhaust duct due to a lack of air, and the engine may stall. These symptoms indicate an imminent clutch failure, consequently the turbocharger should be replaced.

Turbocharger roller-type clutches tend to fail gradually rather than suddenly. This characteristic refers to the fact that in early stages of clutch wear-out, the slippage may be intermittent. In such instances, the engine may smoke heavily

or stall during speed changes, yet behave normally later. To ensure that the clutch is not in this early stage of failure, the aforementioned test procedure may

be repeated a few times. However, articles stating that as many as **30** consecutive tests may be required are in error. To avoid damaging a good clutch, injector linkage manipulation should not be performed more than **2** or **3** times to qualify a clutch. If the clutch is in fact defective, the turbo should exhibit the reference symptoms within this number of trails.

## COMPUTER CONTROLLED BRAKE SYSTEM (CCB)

The loco is equipped with a KNORR brake system. The KNORR system is computer controlled air brake system (CCB). The CCB equipment is a complete microprocessor based airbrake control system. All logics are computer controlled. The driver uses one of the two control stands (cab control unit (CCU) to control the CCB system. Emergency applications are also initiated pneumatically in parallel with computer initiated emergency applications. The main parts of the CCB system are as follow:

### BRAKE VALVE CONTROLLER (BVC)

**Automatic Brake Valve** :( This is for the full train with loco.)

Automatic Brake valve having 5 positions:

➤ **Release/Overcharging)**

(Spring-loaded)-5kg/cm<sup>2</sup>.

➤ **Running:**

ER and BP Pr. =5.2kg; /cm<sup>2</sup>.

➤ **Minimum service:**

ER/BP reduce to 4.7kg/cm<sup>2</sup>, BCP=1.1kg/cm<sup>2</sup>

➤ **Full Service**

ER reduce to 3.4kg/cm<sup>2</sup>, BCP= 4.35kgs/cm<sup>2</sup>

➤ **Emergency**

ER reduce to 0, BP, reduces to <1.0kg/cm<sup>2</sup>

BCP=4.35kg/cm<sup>2</sup>, BCEP=3.57kg/cm<sup>2</sup>

ER =Equalizing reservoir pressure

BP=Brake Pipe pressure

BCP=Brake cylinder pressure



### **Independent Brake Valve:**

(This is for the loco brake only) It is direct Brakes having following positions

- **Release positions**

BCP=0

- **Application zone**

Max Brakeposition:BCP5.2kg/cm<sup>2</sup>

BCEP=3.7Kg/cm<sup>2</sup>

*BCEP =Brake cylinder equalizing pressure*

- **Bail off**

When an automatic brake is applied, lifting the bail off ring which is provided in the brake valve handle in any position will release BC as a result of BP reduction. Independent brake handle bail off ring is spring-loaded and by lifting it the bail off function will actuate.



CONTROLSTAND

### **Selector Switch or Air Brake Trial /Lead Set Up Switch:**

The trail/Lead setup switch is located on the brake control next to independent brake handle. The switch has the following 3 positions:

- **Trail**

Used with loco in trailing position and on non-working control of the working loco.

- **Lead-In:**

Used with loco in leading unit or controlling unit in MU consists. Airbrake system responds to air brake handle movements when trail/Lead switch is in this position.

- **Lead-Out:**

Used during brake pipe leakage testing and on banking loco control stand.

### **Air Brake Equipment Rack:**

Provided in the nose compartment consisting following:

- Voltage conditioning Unit (VCU)
- Computer Relay Unit (CRU) or Air Brake computer
- Analog Converters.
- Magnet Valves
- Pneumatic Valves
- Filters
- Transducers
- KE Distributor Valve (Back-up valve)
- Reservoirs

### **Brake Pipe Control System**

According to the auto brake valve controller handle position, signals from the brake handle will go to the fibre optic receiver (FOR) then to the air brake computer. Computer will send signals to analog converter.

The analog converter operates magnet valves provided in it and from the magnet valves piloting air pressure will go to the other main magnet valve which is controlled by CCB computer. The output air pressure of the main magnet valve is called as equalizing Reservoir and is acting as pilot pressure for the BP relay valve. BP relay valve is a self-lapping pressure maintaining pneumatic valve which maintains the BP pressure to the level of ER against train brake pipe leakage conditions.

There are transducers provided in the ER pipe and BP pipe to send feedback signals to the computer regarding the pressures available or maintained in the respective pipelines.

### **Emergency Application:**

An emergency application means to apply brakes at the maximum rate. When the brake valve handle is placed in the emergency position, ER reduces at the faster rate to zero pressure and also the brake valve mechanically opens a vent valve. In addition the brake controller is provided with a switch which opens sending an emergency signal to the computer. Then the computer energizes an emergency magnet valve (MVEM). The opening of MVEM vents the pilot port of the high capacity BP relay pneumatic valve (PVEM) exhausting BP pressure.

### **Automatic Brake Application on Loco:**

The brake pipes transducer (BPT) provided in the BP pipe detects the reduction in BP and sends signal to computer. The computer calculates the required brake cylinder pressure and commands the BC analog converter to maintain the desired rate of pressure level in the brake cylinder. The brake cylinder analog converter operates a BC magnet valve. The output pressure of the BC magnet valve work as a pilot pressure for the BC relay valve. BC relay valve is a self-lapping pressure maintaining pneumatic valve which will come to the lap position when matches with the BC pilot air pressure. The application is complete if the BC pressure is maintained at the level commanded by the computer until the brake valve handle is again moved.

### **Bail-Off Automatic Application:**

When the automatic brake is applied lifting the bail-off ring provided in the independent brake valve handle in any position will release the brake cylinders of loco.

On the Lead Unit, the CCB Computer commands the BC analog convertor to release the pilot air pressure, which, in turn drives the BC relay valve to release the BC pressure. If an emergency brake has been made, the brake will re apply to maximum as soon as the bail off ring is released

**NOTE;-** If the bail-off continuous for longer than 50 seconds the BC pressure will be restored and a fault will be displayed on the EM2000 display screen. The crew messages the centre point of display and it will indicate fault condition that required immediate attention.

### **Independent Brake Operation:**

According to the independent brake valve controller handle position, signals from the brake valve handle will go to the fibre optic receiver (FOR) and then to the computer. Computer will send signals to the BC analog converter. The analog converter operates the BC relay valve. BC relay valve is a self lapping pressure maintaining pneumatic valve which will come to the lap position when matches with the BC pilots air pressure.

Any leakage in the BC pipe will be noticed by the BC transducer (BCT) and the feedback signals will go to CCB computer. Then computer will in turn take corrective action to maintain BC pressure. The BC equalizing pipe (BCEP) is used to supply air to end from all the trailing units of the locomotive consists to control application and release of both automatic and independent brakes. The only exception to this operation is locomotive consist separation.

According to the service positions of the brake controller valve handles, CCB computer gets signals from the FOR. Then the computer sends the signals to

BCEP analog converter to supply piloting air pressure to BCEP relay valve when the BC pressure equalizes BCEP, the BCEP relay valve moves to LAP position.

Maximum BCEP=3.7Kg/Cm<sup>2</sup>

### **Introduction to Blended Brake System**

The passenger service locomotive is equipped with a blended brake system. It simultaneously applies dynamic braking and air braking when the driver operates the automatic air brake handle in the service zone.

The Knorr CCB air brake system controls the air brakes on the locomotive and carriages coupled in trains and requests the required amount of dynamic braking from EM2000 computer for blended brake operation

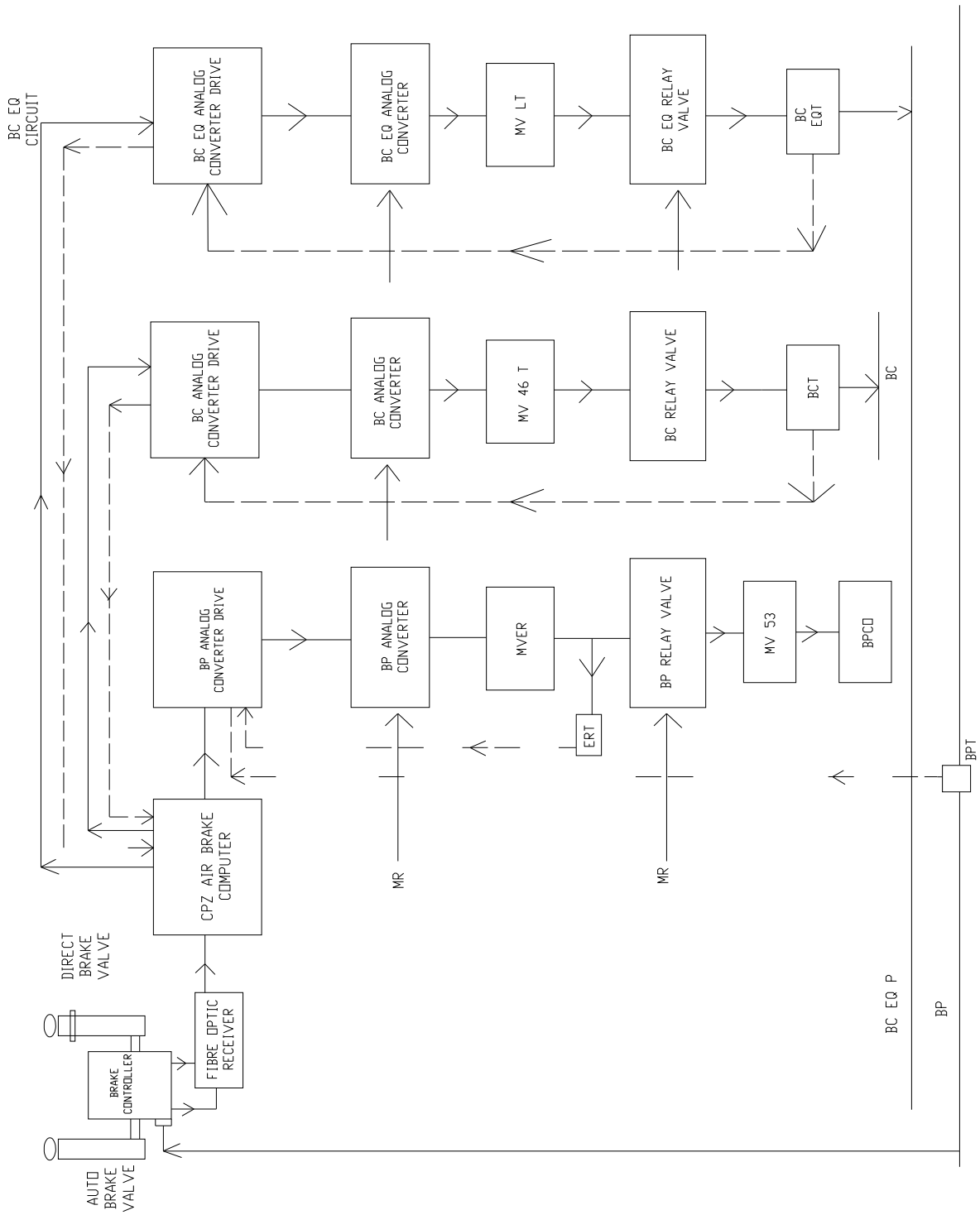

COMPUTER CONTROLLED BRAKE SYSTEM

## **FUEL OIL SYSTEM (HHP)**

The fuel oil system is designed to supply fuel to the engine in **correct quantity and at the right time** according to the engine requirements. The fuel oil system draws fuel from fuel tank, filter the fuel, pressurise the fuel, and inject the fuel into the engine in correct quantity in atomised condition.

Fuel Oil System Consist Of

1. Fuel feed system
2. Fuel injection system

### **FUEL FEED SYSTEM**

Fuel is drawn from the fuel oil tank through a suction strainer by the fuel pump. The strainer separates foreign particles from the fuel oil, and protects the fuel pump. The pump is designed to supply adequate quantity of fuel to the engine at various speeds and load conditions.

Fuel then goes into primary filter. This primary filter is provided with a 30 PSI bypass valve with sight glasses, which should be normally empty. Whenever primary filter is choked/clogged and the pressure difference reaches 30 PSI this bypass valve opens allowing the fuel directly to the system, which can be noticed by the flow of bypass fuel in the sight glass. Under such cases, the primary filter element is changed.

The fuel then passes to 02 engine mounted secondary filters, which are of spin-on type. Secondary fuel filters are also provided with a by-pass valve, which is set at 60 PSI. Whenever the filters are choked/ clogged and the pressure difference across the secondary filters reaches 60 PSI, this by-pass valve opens and diverts

the fuel oil back to fuel tank, avoiding damage to fuel injectors due to unfiltered fuel oil. A bye-pass sight glass is also provided to indicate the condition of the fuel secondary filters and the sight should be normally empty.

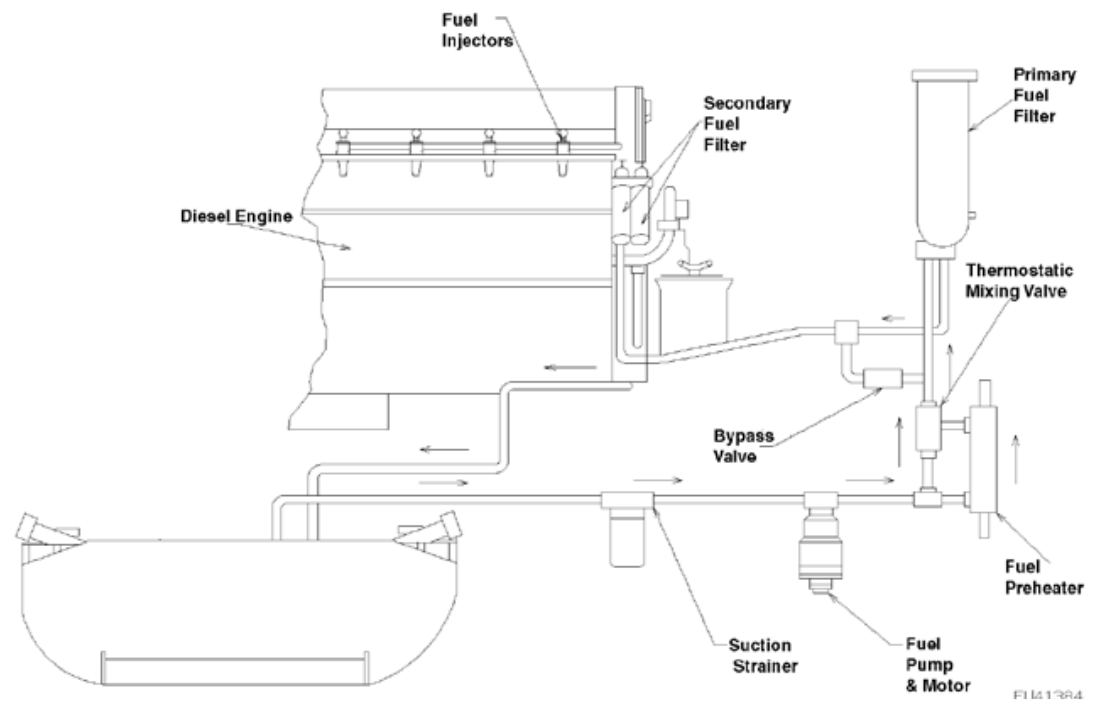

## FUEL OIL SYSTEM

The secondary filters the fuel oil is supplied to all unit injectors through fuel supply manifolds located inside the top deck on the both banks. The governor controls the quantity of fuel to be injected through the injectors to the engine. At the end of the fuel supply manifolds, a regulating valve with a sight glass is provided which is set to 10 PSI. The regulating valve ensures constant fuel supply to all unit injector in all working conditions. If the system is working properly the sight glass



should indicate clear and clean fuel oil flow all the time. Air bubbles, interrupted fuel flow or no fuel flow in the return sight glass indicates problem in the fuel feed system.

## **FUEL INJECTION SYSTEM**

Fuel supplied by the fuel feed system is always available at all the unit fuel injectors. The fuel oil available at each injector are to be pressurized to very high pressure, timed and to be injected in the cylinder in atomized form. The timing of each unit injector is decided by the camshaft and the fuel is pressurized by the in-built fuel injection pump which is operated by individual cam lobe of the cam shaft.

The quantity of fuel to be injected will be regulated and controlled by engine mounted wood word governor according to the notch and load conditions. The governor operates fuel control shaft, linkage mechanism and fuel racks. The individual fuel injector nozzle does the atomization of the fuel to be injected in the cylinder.

## FUEL OIL SYSTEM WDP4 / WDG4

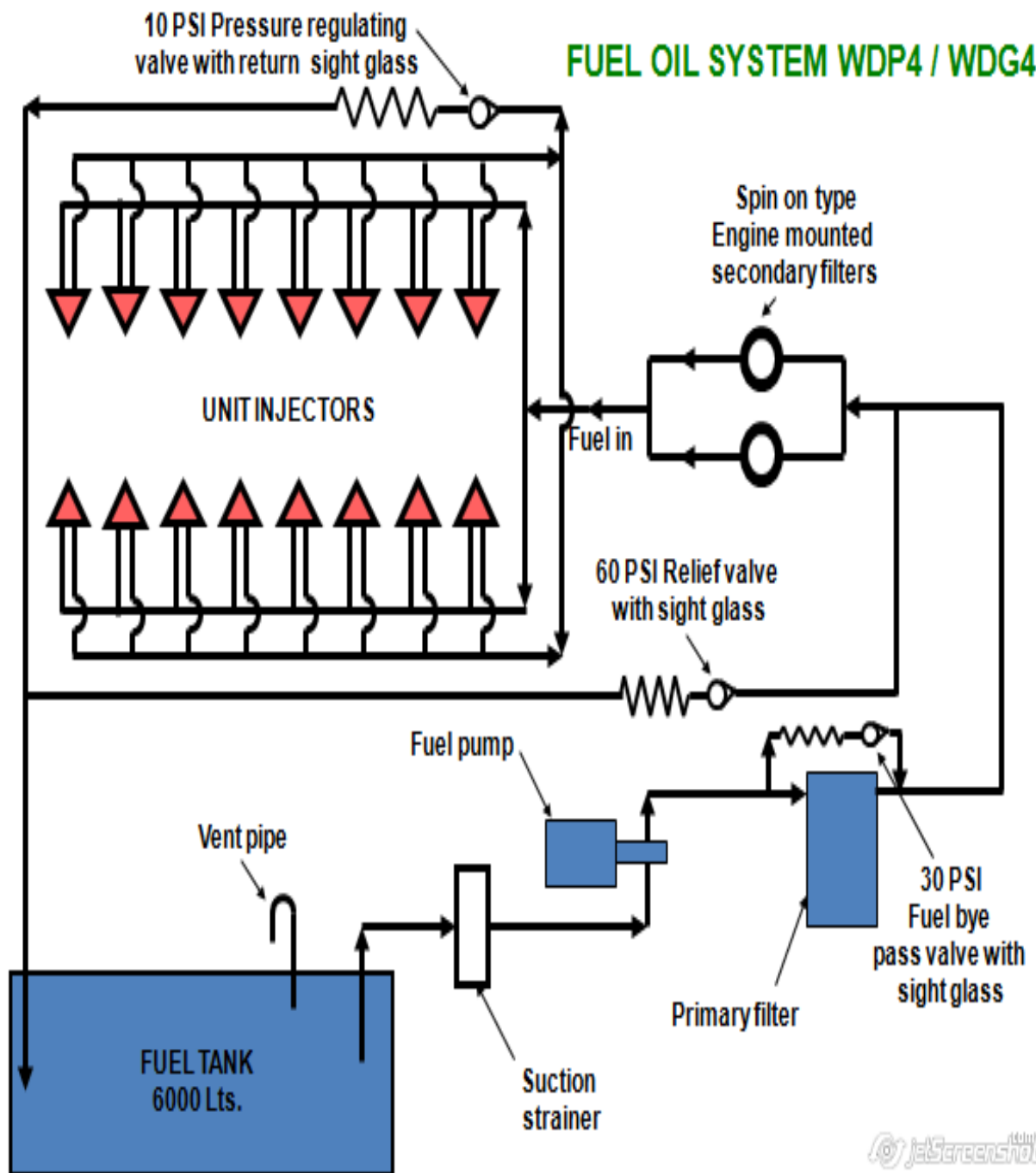

## LUBE OIL SYSTEM

The complete engine lubricating oil system is a combination of 04 oil systems. These are:

- (1) Scavenging oil system
- (2) Main lubricating oil system
- (3) Piston cooling oil system
- (4) Soak Back or turbo lube system

### LUBE OIL PUMPS

- Each system has its own lube oil pump.
- The main lube oil pump, piston cooling oil pump and scavenging oil pumps are driven from the accessory gear train at the front end of the engine.
- The soak back or turbo lube system is driven by a electric motor.
- The main lube oil pump and piston cooling oil pump is a individual pump but both contained in one housing and driven from a common drive shaft.

### Scavenging Oil System

The scavenging oil pump is a positive displacement, helical gear type pump. This pump takes lube oil from 02 sources- from the engine oil sump and from the oil strainer.

The pump feed lube oil to lube oil filter tank (also called Michiana oil filter). Oil from the filter tank gose to lube oil cooler where it is cooled by the engine cooling system. Oil then passes to lube oil strainer where it is filtered once again. The oil filter (Michiana oil filter) contain 5 paper type filter elements. A bypass valve provided across the filter tank and set at 40 PSI. If the filter is clogged and pressure difference

reaches to 40 PSI oil is by passed to lube oil cooler. This ensures adequate lube oil supply to the engine avoiding damages to the moving parts. The oil filter and the lube oil cooler are located in the equipment rake. The lube oil strainer is having 02 fine mesh strainer elements.

### **Piston Cooling Oil System:**

There is a suction pipe (coming from the lube oil strainer) for the piston cooling oil system and the main lube oil system. The piston cooling oil system pump receives oil from a common suction pipe and delivers oil to the 2 piston cooling oil manifolds extending the full length of the engine, one on each bank. A piston cooling oil pipe at each cylinder directs a stream of oil to cool the underside of the piston crown. This stream of oil also lubricate the ring belt. Some of this oil enters oil grooves in the piston pin bearing for lubrication. Oil after cooling and lubrication drains back in to the oil sump.

### **Main Lubricating Oil System:**

The main lubricating oil system supplies oil under pressure to most of the moving parts of the engine. The main lube oil pump takes oil from the strainer housing through a common suction. Oil from the pump goes to the main oil manifold, which is located above the crankshaft, extends to the length of the engine. Maximum oil pressure in the system is control by a relief valve in the passage between the pump and the main oil manifold. The pressure relief valve is set to 125PSI, which relives excess oil back to the sump.

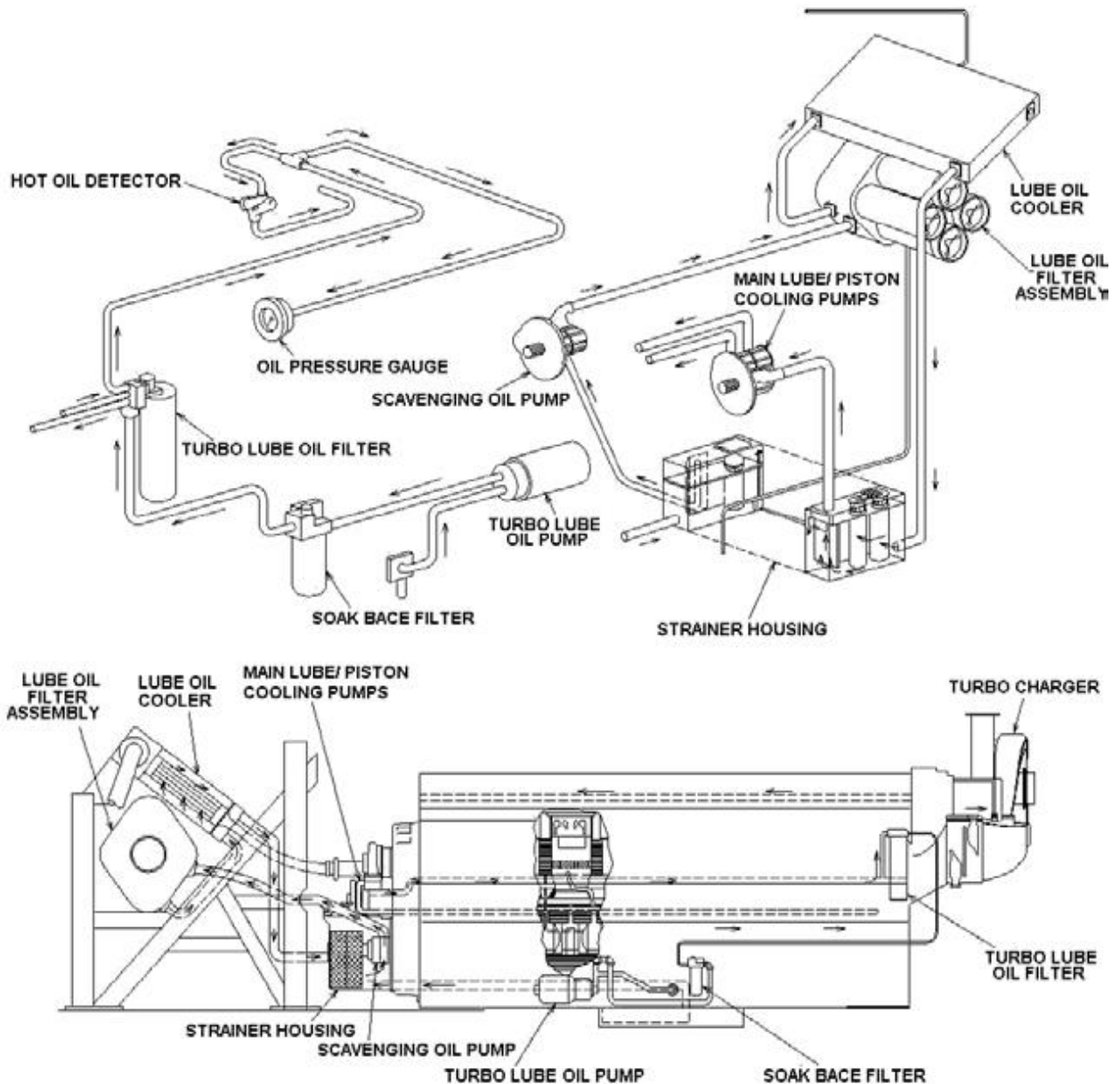

### LUBE OIL SYSTEM (HHP)

Oil tubes in the centre of the each main bearing receives oil from the main manifold to the upper half of the crankshaft main bearings. Drilled passage in the crankshaft supplies oil to the connecting rod bearings, vibration damper and accessory drive gear at the front end of the crankshaft. Oil from the manifold enters gear train at the rear end of the engine at the idler gear stub shaft. Oil passes in the

base of the stub shaft from where oil is distributed to various parts through passage. One passage conducts oil to the left bank camshaft drive gear stub shaft bracket through a jumper. Another passage conducts oil to the Right Bank camshaft drive stub shaft bracket and the turbo charger oil filter supply line.

Oil enters the hollow bore camshaft from the camshaft stub shafts. Radial holes in the camshafts conducts oil to each camshaft bearing. An oil line from each camshaft bearing at each cylinder supplies oil to the rocker arm shaft, rocker arm cam follower assemblies, hydraulic lash adjusters and to rocker arm. Leaks of oil return to the sump.

The turbo charger oil filter supply line sands oil to the turbo lube oil filter which sands oil to the turbo oil manifold and then to turbo for cooling and lubrication. A branch line taken to the wood word governor low lube oil pressure shut downdevice and also to the hot oil detector. The minimum oil pressure is approximately 8-12 PSI at idle and 25-29 PSI at full speed. In the event of insufficient oil pressure, a shutdown feature in the governor will automatically protect the engine by shutting down.

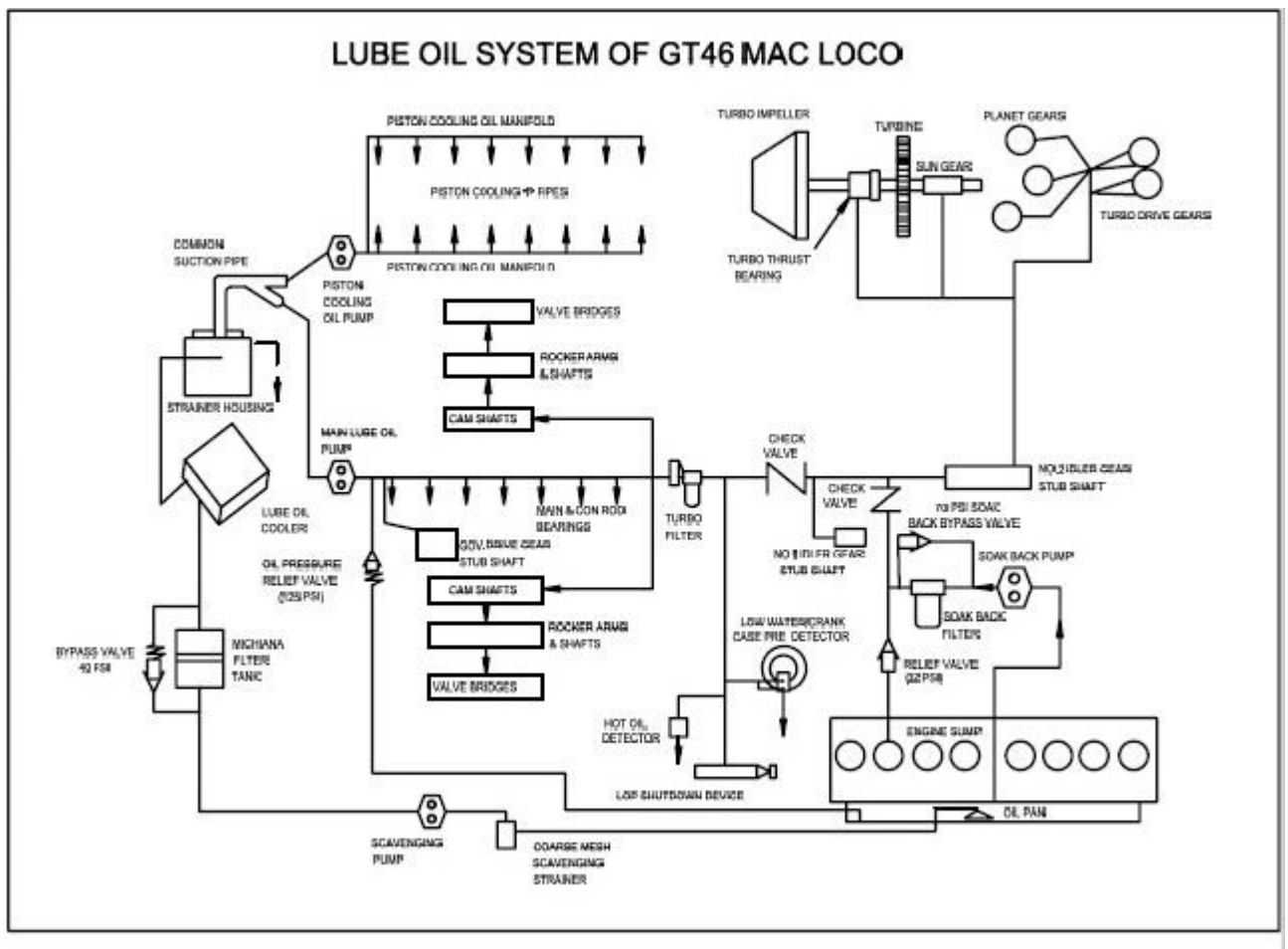

## LUBE OIL SYSTEM

The turbo charger oil filter provides additional protection for the high-speed bearing and other lubricated areas of the turbo. The filter head contains 2 check valves, one to prevent the lube oil from the soak back system from going into the turbo charger filter during soak back pump operation and the other to prevent lube oil from the turbo charger filter from entering the soak back system when the engine is running. Passages in the turbo charger conduct oil to the turbo bearings, idler gear, planet gear assembly and auxiliary drive bore.

### **Soak Back Oil System:**

To ensure lubrication of the turbo charger prior to the engine start and the removal of residual heat from the turbo after engine shutdown, a separate lube oil pressure source is provided. This pressure system is controlled automatically by the locomotive control system.

An electrically operated turbo soak back pump draws oil from the oil sump, feed the oil through a soak back filter and finally to the turbo. A 70-PSI soak back filter bypass valve is provided inside the soak back filter housing to bypass filter whenever it clogs to protect Turbo-charger.

This soak back pump automatically starts working before cranking the engine. When the engine start, the motor driven soak back pump is still running, main lube oil pressure from the engine driven pump becomes greater than the motor driven soak back pump pressure. As there is no outlet for the lower pressure oil, the relief valve is provided in the filter head set to 32 PSI will return the oil back to engine sump. Considerable heat will remain in the metal parts of the turbine when the engine is shutdown and due to sudden cut off oil supply to the bearings, damage or more wear will take place in the bearings since the turbo rotor will be rotating even after the engine stops due to its momentum. To avoid the thermal stressing and unwanted wear in the bearings due to no oil supply, this soak back pump automatically starts working after shutting down of the engine. Soak back pump will be working for 30 to 35 minute approximately even after engine shutdown. This ultimately increases the life of the turbo.



### **LUBE OIL SEPARATOR:**

The oil separator is an elbow shaped cylindrical housing containing a wire mesh screen element. It is mounted on turbo charger housing. An elbow assembly connects the separator to the ejector tube assembly in the exhaust stack. The eductor tube in the exhaust stack creates suction in the engine crankcase and draws up oil vapor from the engine crankcase, while doing so. The oil drawn will be collected on the wire mesh element and drain back to the engine sump.

### **HOT OIL DETECTOR:**

Normally there is a close relationship between engine coolant temperature and engine lube oil temperature. Hot oil detector senses the oil temperature and send informations to EM2000. If the temperature of the oil exceeds approximately 255 degree F (124 degree C) EM 2000 will shut down the engine through governor and the fault will be display.

## COOLING WATER SYSTEM OF WDG4/WDP4

Engine cooling water system is a closed loop pressurized water cooling system. The engine cooling system consists of engine driven centrifugal water pumps (2), replaceable inlet water manifolds (2) with an individual jumper line to each liner, cylinder head discharge elbows, and an outlet manifold through which cooling water is circulated. The centrifugal water pumps (one on an 8 cylinder engine) are mounted on the accessory drive housing and are driven by the governor drive gear. The water cooling system cools all the engine cylinder liners, cylinder heads, after cooler, lube oil cooler and compressor.

- In the water cooling system, there are 02 no. of engine mounted **water pumps (centrifugal type)**.
- The water pump receives water from the radiator through lube oil cooler.
- Water from the water pump is sent to the two (left and right bank) **water main headers (also called water inlet manifold)**.
- From the water main header water enter to all the cylinder liner jackets through water jumper.
- After cooling the cylinder liners water enter in the cylinder head through 12 holes which are matched to cylinder liner with “O” rings and cool the combustion chamber of the cylinder head.
- Outlet water from each cylinder head goes to the **return header (also called water outlet manifold)** which carries water to the radiator.
- Each **water main header** is connected at the rear end from where water pipe line carries water to cool the after cooler.

- Water from the after cooler goes to water return header and through water return header to radiator.
- A water pipe line from the water pump carry water to compressor to cool the compressor liners, cylinder head, valves and the compressed air inside the inter cooler. Air compressor cooling is done whenever engine is running.

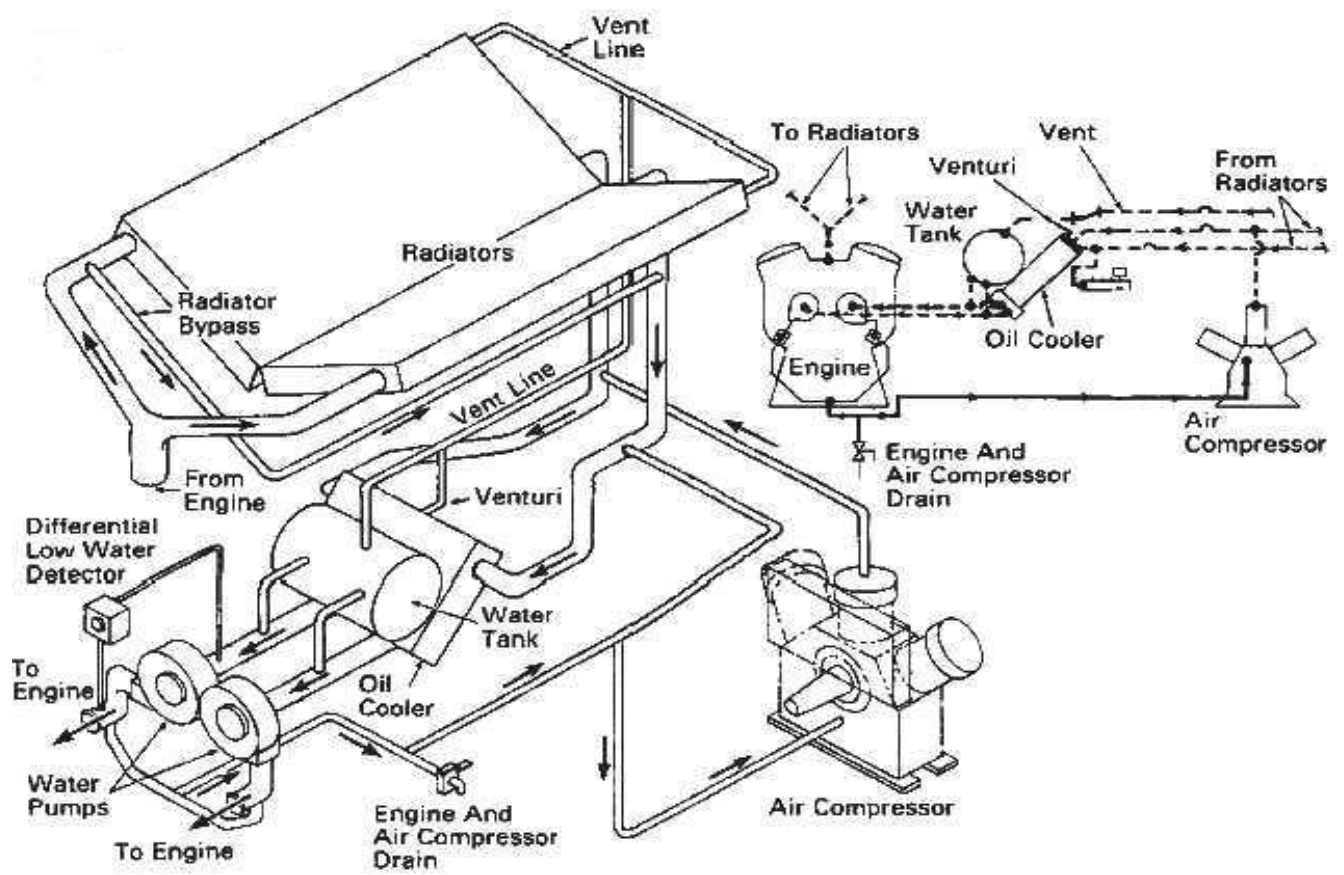

### WATER COOLING SYSTEM IN WDG4/WDP4

#### **DETAILS ABOUT RADIATOR**

- The radiators are located in a hatch at the top of the long hood end of the locomotive.

- The hatch contains the radiator assemblies, which are grouped in two banks. Each radiator bank consists of two quad length radiator core assemblies, bolted end-to-end.
- Headers are mounted on the radiator core to form the inlet and outlet ends of the radiator assembly, a bypass line is provided between the inlet and outlet lines in order to reduce velocity in the radiator tubes.
- Two 8-blade 52" cooling fans, which operate independently, are located under the radiators in the long hood carboy structure. They are numbered 1, and 2, with the No. 1 fan being closest to the driver cab.
- The water pump inlet side is connected to an expansion tank for makeup water in the water system. The expansion tank is located in the equipment rack.

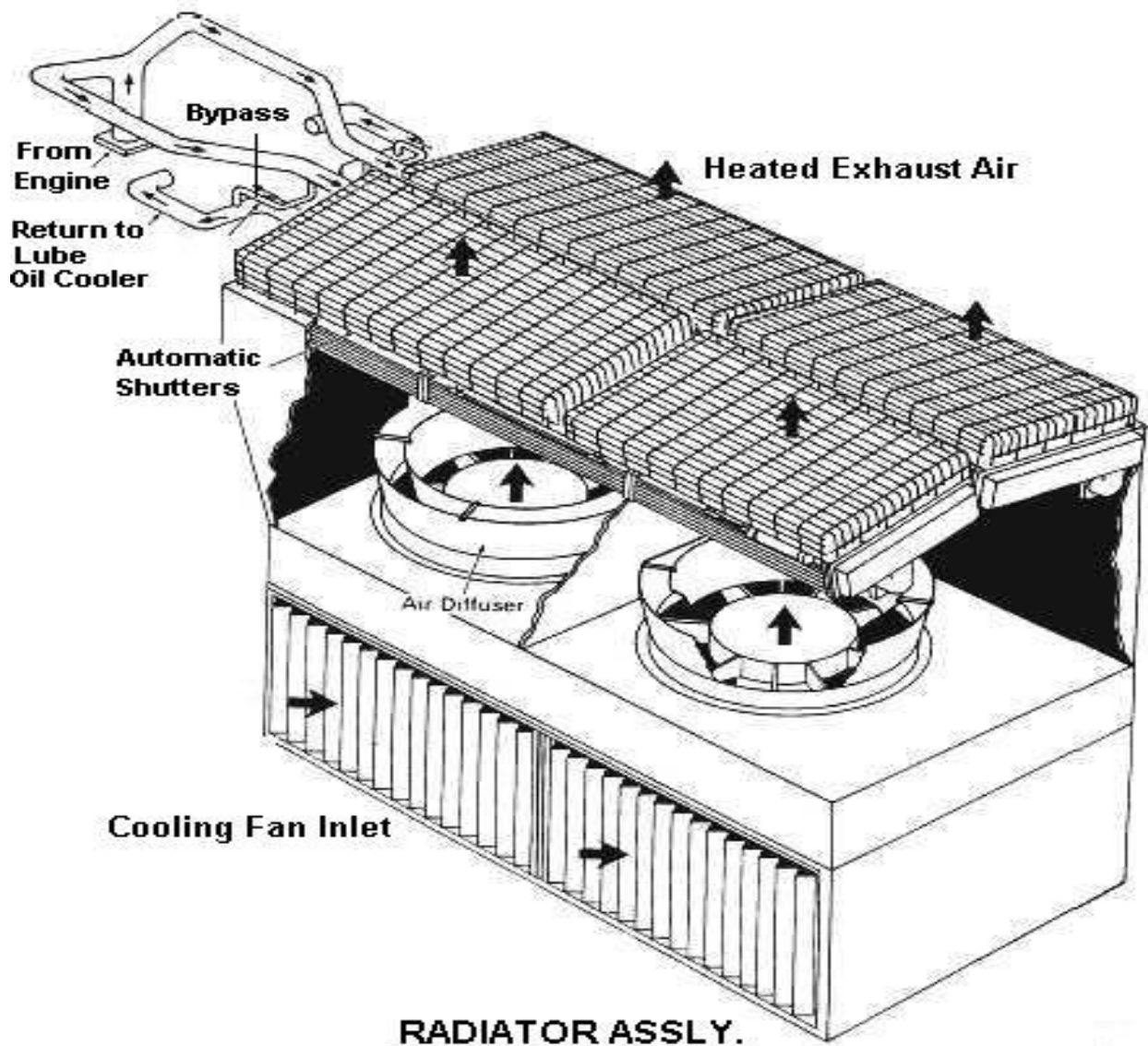

## TEMPERATURE CONTROL BY THE COOLING SYSTEM

- Mainly the two electronic **temperature sensing probes (ETP1& ETP 2)**, **EM2000 computer** and the **radiator fans** take part in controlling the water temperature.

- Two electronic temperature-sensing probes (ETP1 & ETP 2) are located in the water pipe line between the lube oil cooler to the inlet of the water pump on the engine left side.
- Temperature probe readings are converted by **ADA Module** from analog to digital signals which are used by the EM2000 to control all cooling functions.
- Each cooling fan is driven by a **two-speed AC motor**, which in turn is powered by the companion alternator.
- As the engine coolant temperature rises, the fans are energized in sequence by the control computer (slow speed). As additional cooling is required, the fans switch to full speed in progression as coolant temperature rises. As coolant temperature drops, the fans switch off one at a time.
- The cooling fans are controlled by the computer which acts on the contactors. The computer also controls the fan sequencing duty cycle (on period/total period) and speed (low or high) to ensure even fan and contactor wear.
- The engine water temperature can be observed by a gauge located on the inlet line to water pump. The gauge is color coded to indicate **cold (Blue), normal (green) and hot (red)**.
- When the engine temperature becomes excessively high, the EM 2000 will display "**HOT ENGINE**"- and **throttle 6 limit**" message. The computer will initiate the reduction in engine speed and load up to 6th notch. This condition will remain in effect until the temperature return to safe limit.
- If the engine water temperature is below 115 °F (46 °C), the engine speed will be raised to throttle 2 automatically by the computer.
- Once the engine water temperature reaches above 125 °F (52 °C), the engine speed will be reduced to IDLE.

- The reason for engine speed up will be displayed to the driver on EM 2000 computer monitor as “**Engine speed increase- low water temperature**”.

## **COOLING SYSTEM PRESSURIZATION**

The cooling system is pressurized to increase the boiling point of the coolant, prevent cavitations at the water pumps during high transient temperature conditions, and to provide uniform cooling throughout the operating range of the diesel engine. The expansion tank has a pressure cap that regulates system pressure at 7, 12, or 20 psi (48, 82 or 138 KPu) depending on engine requirements.

## **OPERATING WATER LEVEL**

The operating water level indicator indicate minimum and maximum water level with the engine running or stopped. The water level mark should not be permitted to go below the applicable “low” water level mark. Progressive lowering of the water in the gauge glass indicates a water leak in the cooling system, and should be reported.

The coolant is circulated through the engine to transfer heat from the engine components to the radiators. **Engine coolant** is composed of **water, corrosion inhibitor**, and when considered necessary, **antifreeze**.

## **COOLANT:**

To be suitable for use in EMD engines, a coolant must meet four Basic requirements:

- Adequately transfer heat energy through the cooling system

- Not form scale or sludge deposits
- Prevent corrosion inside the cooling system
- Can't deteriorate seals or gaskets in the cooling system

## **WATER**

The water in some areas contains elements such as excessive solids, hardness salts, or corrosive elements such as chlorides that make it unsuitable for use in the cooling systems of EMD engines. Water from these sources should be processed by **softening**, **de-ionizing**, or **distillation** to make it suitable for cooling system use.

## **CORROSION INHIBITOR:**

The main type of corrosion inhibitor for EMD engines is the **borate-nitrate type**. Borate-nitrate is available in powder, pellet, and liquid form. Powder and pellet form inhibitors should be dissolved in water in a separate container before being added to the cooling system. The level of borate-nitrate should be maintained in a concentration above **5625** parts per million.

## **WATER PUMPS:**

The two engine cooling water pumps (**one on 8 cylinder engines**) are self-draining centrifugal pumps, which rotate in the opposite direction of the engine crankshaft.



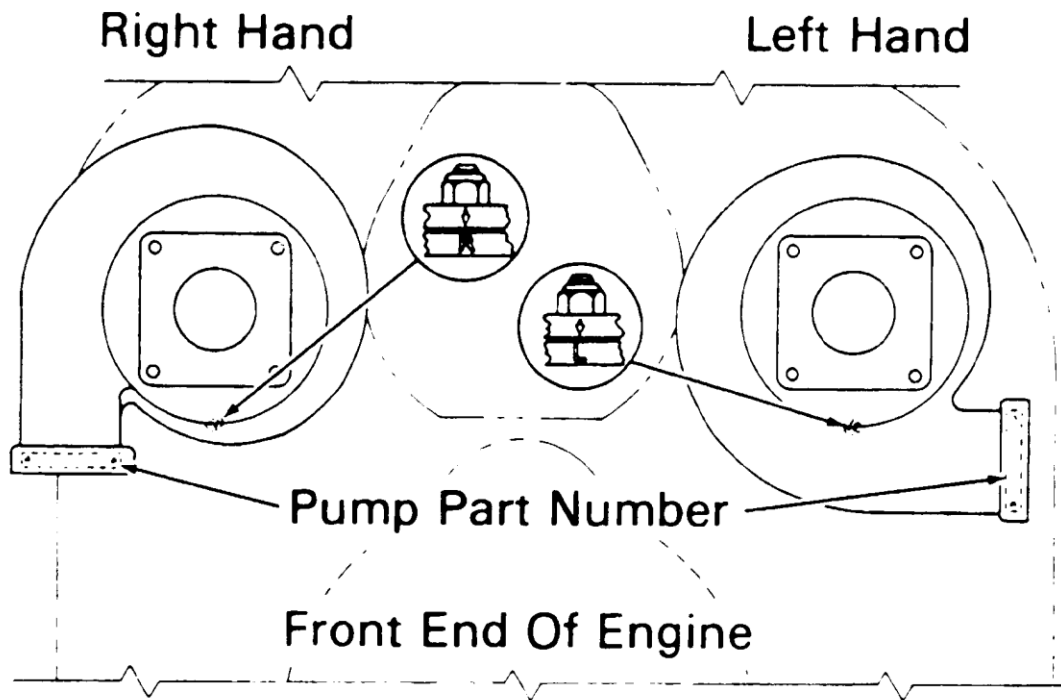

F13825

---

WATER PUMPS

## 9.GOVERNORS USED IN DIESEL LOCOMOTIVES

### TYPES OF GOVERNERS

There are **three types of governors** in use:

- GE GOVERNOR
- MICRO PROCESSOR BASED GOVERNOR.
- WOOD WARD GOVERNOR

It is provided to control fuel supply of engine to achieve following functions.

### FUNCTIONS OF GOVERNOR

- 1) For starting the Diesel engine and bringing to idle speed during cranking.
- 2) To affect the engine speed changes according to **throttle handle (TH)** position duly controlling the fuel supply to the engine.
- 3) Maintains a constant engine speed for a particular notch regardless of load.
- 4) Prevents the overloading of Diesel engine through LCR and engine bogging down is avoided.
- 5) Normal shut down of the Diesel engine is done by the Gov. through **MUSD** or **STOP** switches.
- 6) Brings the engine to shut down during abnormal conditions such as low lube oil pressure, engine over speed, low water level etc and protects the engine from damages.

7) Brings the engine to idle during power grounds, hot engine, train partings, reduction in vacuum, emergency brake applications etc. for safety of the engine and the train.

8) Acts as an agent to match the generator demand with the engine capability.



### WOOD WARD GOVERNER

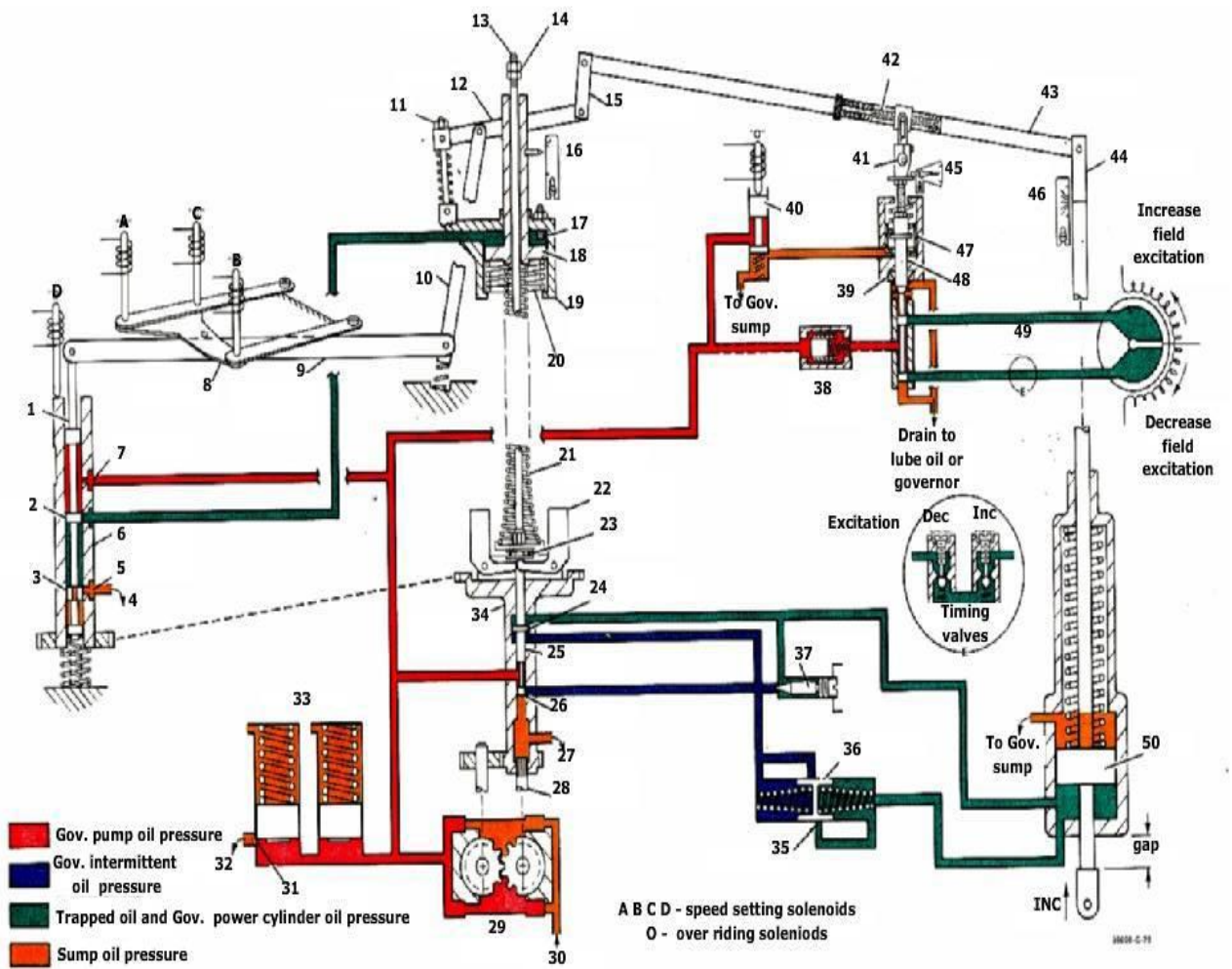

## GOVERNING SYSTEM

## PARTS OF WOODWARD GOVERNOR

1- Speed setting valve plunger	18- Speed setting piston	35- Bypass port
2- Control stand	19- Speed setting cylinder	36- Buffer piston
3- Slotted drain land	20- Speed setting servo spring	37- Compensation needle valve
4- Governor sump	21- Speeder spring	38- Load control supply valve(Integral vane servo)
5- Intermittent drain port	22- Fly weight	39- Oil seal (Remote servo)
6- Bushing (rotating)	23- Thrust bearing	40- Overriding valve plunger
7- Intermittent supply port	24- Compensation land	41- Eccentric Level Adjustment
8- Triangular Plate	25- Pilot valve plunger	42- Range Adjustment Screw
9- Speed setting floating lever	26- Control land	43- Load control floating lever
10- Restoring Link	27- Governor sump	44- Tail rod

11- Base setting nut	28- Drive Shaft	45- Load control position indicator
12- Restoring lever	29- Oil pump	46- Power piston travel gap indicator
13- Shutdown rod	30- Sump	47- Overriding piston
14- Shutdown nuts	31- Relief port	48- Load control pilot valve plunger
15- Link	32- Governor sump	49- Vane servo and rheostat
16- Speed setting indicator	33- Accumulators	50- Power piston
17- Piston stop	34- Fly weight and Bushing	

## WORKING OF WOODWARD GOVERNOR

- The Woodward governor for locomotive applications is a standard **hydraulic governor** which regulates engine speed with a number of special devices for locomotive and train operation.
- It **senses engine rpm mechanically** from cam gear through a set of gear train constituted in the base unit.
- It includes an **electro-hydraulic speed setting mechanism** for remote control of engine speed, a **mechanical-hydraulic load control device** for automatic regulation of engine load to maintain a specific power output at

- each speed setting, and a **single acting spring return hydraulic power servo**.
- The power servo has a reciprocating or linear output. The governor usually has both a servomotor and a rheostat as an integral part of the governor to adjust the generator exciter rheostat.

The basic Woodward locomotive governor has three functional sections:

1. Basic governing section
2. Speed setting section
3. Load control section.

#### **Basic Governing Section:**

- This section consists of **an oil pump, two accumulators, a speeder spring, a flyweight head and bushing assembly, a thrust bearing, a pilot valve plunger, a buffer compensation system, and a power cylinder**.
- The governor drive shaft passes through the governor base and engages the flyweight head and bushing.
- The **pump** supplies pressure oil for operation of the basic governor section, the speed setting section and the load control system.
- A **spring loaded accumulator** and **relief valve system** maintains the governor oil operating pressure at 100 psi.
- Where the operating pressure is reached, the spring pressure is overcome and the oil is released to sump. The four check valves in the pump ensures same direction of flow regardless of the direction of rotation of the pump.

- The governor drive rotates the oil pump and the flyweight head and bushing. A thrust bearing rides on top of the flyweight head, permitting the rotational motion between the downward force of the speeder spring and the upward force of the flyweights. The greater of two opposing forces moves the pilot valve plunger up or down.
- Flyweight force tends to lift the plunger while speeder spring force tends to lower the plunger.
- When the engine is on speed at any speed setting, these forces are balanced and the flyweights assume a vertical position. In this position, the control land on the pilot valve plunger is centred over the regulating ports in the rotating bushing. A change in either of these two forces will move the plunger from its centred position.
- **Lowering of plunger** (1) When the governor speed setting is unchanged but an additional load slows the engine and governor (thereby decreasing Flyweight force) or (2) When engine speed is unchanged but speeder spring force is increased to raise the governor speed setting.
- **Raising of plunger** (1) When the governor speed setting is unchanged but load on the engine is reduced causing a rise in engine and governor speed (and hence, an increase in flyweight force), or (2) Where engine speed is unchanged but speeder- spring force is reduced to lower the governor speed setting.
- When the plunger is lowered (an under speed condition) pressure oil is directed into the buffer compensation system and power cylinder to raise the power piston and increase fuel. When lifted (an over speed condition) oil is



- permitted to drain from these areas to sump and the power piston moves downward to decrease fuel.
- The **buffer piston, springs and needle valve** in the hydraulic circuits between the pilot-valve plunger and power cylinder make up the buffer compensation system. This system functions to stabilise the governing action by minimising overshoot or undershoot following a change in governor speed setting or a change in load on the engine.
- It establishes a temporary negative-feedback signal (temporary droop) in the form of a pressure differential which is applied across the compensation land of the pilot valve plunger.
- The flow of oil into or out of the buffer system displaces the buffer piston in the direction of flow. This movement increase the loading on one spring while decreasing the load on the other and creates a slight difference in the pressure on either side of the piston with the higher pressure on the side opposite the spring being compressed. These pressures are transmitted to the opposite sides of the plunger compensation land and produce a net force, upward or downward which assists in re centring the plunger whenever a fuel correction is made.

### **Speed Setting Section:**

- This section consists of a **speed setting piston, a speed setting pilot valve plunger housed within a rotating bushing, four speed setting solenoids, a triangular plate, and restoring linkage mechanism.**

- Three of the four speed setting solenoids A, B and C actuate the speed setting pilot valve plunger by controlling the movement of the triangular plate which rests on top of the floating lever attached to the plunger.
- The fourth solenoid D controls the position of the rotating bushing with respect to the plunger.
- Energizing the AV, BV and CV solenoids, singly or in various combinations, depresses the triangular plate a predetermined distance. Energizing the DV solenoid pushes the rotating bushing downward and opens the control port to drain oil from the speed setting cylinder and thus decrease the speed setting.
- Advancing or retarding the throttle control from one step to the next energizes or de-energizes the solenoids in various combinations to increase or decrease engine speeds in approximately equal increments.
- In the arrangement all solenoids are de-energized at IDLE and first notch. Energizing AV increases speed by one increment, BV adds four increments, CV adds two increments and DV reduces speed two increments when used in combination with AV, BV and CV.
- When the throttle is moved to the STOP position, solenoid DV only is energized.
- NORMAL SHUTDOWN:

Under normal operating conditions, the engine is shut down by moving the throttle to the STOP position. This energizes the DV solenoid pushing the rotating bushing down and opening the control port to drain the oil from the speed setting cylinder. The speed setting piston then moves up lifting the shutdown nuts and shutdown rod in the process. This lifts the governor pilot

valve plunger, draining oil from the buffer compensation system and allowing the power piston to move down to the shutdown (no fuel) position.

### **Load Control Section:**

- In most governor applications, the primary function of the governor is to automatically maintain a specific engine speed under varying load conditions by controlling the fuel flow to go to the engine.
- With the locomotive governor, a secondary function is included to maintain a constant engine power output at each specific speed setting. Thus, for each throttle setting, there is both a constant engine speed and a predetermined rate of fuel flow required.
- Control of engine-load is achieved by regulating engine speed and fuel setting. This is done by adjusting the generator field excitation current through the use of a vane servo controlled variable resistance in the generator field circuit. The vane servo is controlled by the load control pilot valve and related linkage in the governor.
- LUBE OIL PRESSURE SHUTDOWN AND ALARM:
  1. Engine oil pressure is directed to the oil pressure diaphragm. The shutdown valve plunger is connected to the diaphragm which has three forces acting on it. **Load spring and engine oil pressures** act to move it to the right while **governor speed setting servo oil pressure** acts to move it to the left. Normally, load spring and engine oil pressures hold the diaphragm and shutdown valve plunger to the right, permitting oil to the left of the shutdown piston to drain to sump.

2. When engine lube oil pressure drops below a safe level, **speed setting servo oil pressure** (which is dependent on the speed setting and on the rate of the speed setting servo spring) overcomes the **load spring and engine oil pressure** forces and moves the diaphragm and shutdown valve plunger to the left.
3. Governor pressure oil is directed around the **shutdown valve plunger** to the shutdown piston and moves it to the right. The shut down piston moves the inner spring and the shutdown plunger to the right.
4. The differential piston with two diaphragms allows a high engine lube oil pressure trip point without a corresponding increase in the speed setting servo oil pressure. The engine lube oil pressure required to initiate shutdown is increased.
5. When the shutdown plunger moves sufficiently, it trips the alarm switch. In addition oil trapped above the governor speed-setting servo piston flows down through the smaller diameter on the left end of the shutdown plunger and drains to sump.
6. This action allows the speed setting servo spring to raise the speed setting servo piston. When the piston moves sufficiently, the piston rod lifts the shutdown nuts and rod. The shut down rod lifts the governor pilot valve plunger. When it is lifted above its centred position oil trapped below the power piston drains to sump and the power piston moves to the no fuel position.

#### **ITEMS TO BE CHECKED ON WW GOVERNOR**

1. Ensure oil level is sufficient in spy glass.

2. Check the condition of Amphenol plug.
3. Ensure no oil leakages.
4. Ensure proper fitment of lube oil pipe line.
5. Ensure proper fitment of booster air pipe line.
6. Ensure proper fitment of governor linkage along with cotter pins.
7. Ensure LLOB is in set position.
8. Ensure the Physical condition of LCR.

## **GOVERNOR HUNTING**

If the Gov. is not in a position to maintain rated rpm of the engine, according to TH it is known as HUNTING and can be indicated by load meter needle fluctuations.

### **Reasons For Hunting**

1. Dirty Governor Oil.
2. Low Gov. Oil pressure: In this case check the Gov. oil pipelines for any leakage and try to arrest.
3. Defective Gov. Mechanism: If the hunting is noticed in a particular notch, avoid that notch and work.

## 10.SAFETY ITEMS

**TRAIN SAFETY DEVICES** - Ensure that these devices are intact for proper working of train by loco pilots.

1. Horn
2. Hand brake
3. Dynamic brake
4. Airbrake system
5. Cattle guard and Rail guard
6. Head light
7. Flasher light
8. Marker lamp
9. Speedometer
10. Wiper motor
11. Emergency brake handle.

## MECHANICAL SAFETY DEVICES

1. **MR safety valve**- prevent the air pressure goes beyond 10.5kg/cm.
2. **LLOB**-shut down the engine when lube oil pressure goes below 7 psi in idle or 24 psi in 8<sup>th</sup> notch or if EPD/Hot oil detect activate.
3. **OST**-shut down the engine if over speed beyond 995.
4. **EPD**-shut down if the engine has positive crank case vacuum or low water pressure.
5. **ELWS**-give warning for low water.
6. **Hot oil detector**- shut down the engine when lube oil temp reaches 122deg.
7. **L R** –Prevent the engine overloading by reducing excitation.
8. **ETP**- Maintains cooling water temp 79 to 85 deg.

9. **TPU**- prevents the turbo over speeding beyond 24000.

## **ELECTRICAL SAFETY DEVICES**

1. **GROUND RELAY**-cut off the power if TA /TCC, TM voltage grounding or imbalance in 3Phase voltage.
2. **MGCTA**-cut off the power by crowbar if TA has over current.
3. **COR RELAY**- cutoff the power whenever emergency brake application.
4. **TM TEMP SENSOR**-reduce the TM power if TM rotor temp goes beyond 225 deg.
5. **TCC TEMP SENSORS**- reduce the power to safe the TCC components.
6. ALL CIRCUIT BREAKERS AND FUSES.

## 11.LOAD BOX TESTING

### PROCEDURE

Load box of diesel loco motoring match the engine performance with the generator demand of diesel locomotive.

The methods of load box are –

1. Grid load box

2. Water load box

1. **Grid load box**: By grid load box we cannot achieved accuracy of parameter for which we used load box because to major horse power curve current and voltage gives to the grids, could not be varies in different notches.

2. **Water load box**: Most of shed use water load box in water load box specific size. MS plates are being use and current given to the plates which is deeped in water; load can be increase and decrease by lowering MS plate in the water tank.

### CONDITION OF LOAD BOX

1. After the major schedule done locomotive

2. Pilot booking of BAP, less and horse power poor.

3. After major component changes or any abnormalities seen by supervisor.

### LOAD BOX CAN BE DONE IN TWO STAGES

1. Preliminary stage

2. Finalstage



1. **Preliminary stage:** In Preliminary stage all the oil level and parameter to be checked by mechanical and electrical and satisfactory parameter to be adjusted and oil level to be added as a required. All gauges to be fitted to measure the parameter and all electrical connection to be made to load box with the locomotive.

Mechanical parameters should be checked in every notch and if found adequacy to be mention properly. Electrical parameter i.e. that is reference current and voltage to be checked and maintain as per requirement GF on and off position.

MLR -31.4 Mile amp. (GF off) 32 Mile amp. (GF on).

No load voltage – 760volt to 765volt

2. **Final stage:** In every notch by putting on the GF On current and voltage to be noted and if current and voltage could not get as per requirement, we checked the system and rectify.

We plot the voltage and current graph of a every notch, we get H.P. constant curve if constant curve is ok and then we can understand loco is ok.

Mechanical side check all the leakage every system if found any leakage arrest then. We check the following parameters are as -

1. Fuel rack - Idle -1.1mm, full notch – 27.5mm
2. Lube oil pressure - Idle – 2.2kg/cm<sup>2</sup>, Full notch – 5.2kg/cm<sup>2</sup>
3. Fuel oil pressure - Idle – 3.8kg/cm<sup>2</sup>, Full notch – 4 kg/cm<sup>2</sup>
4. BAP pressure - Idle - 1.8 to 2.2 kg/cm<sup>2</sup> (if varies on turbo used)
5. Exhaust gas temperature – exhaust manifold – 476 O C Turbo inlet - 525 O C

