

CASNUB BOGIE

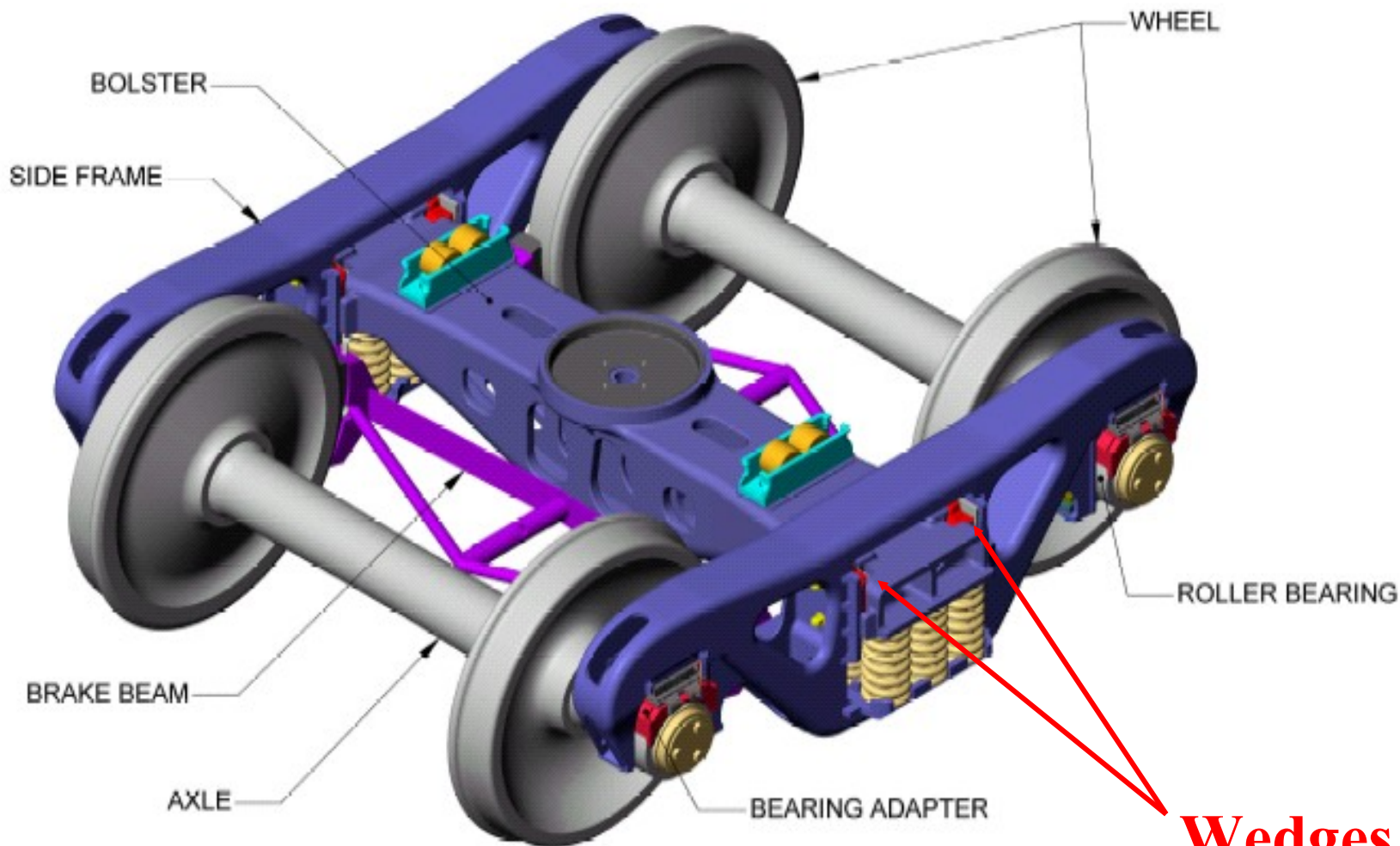

Wedges

The various bogie versions developed are as under:

- CASNUB -22W
- CASNUB -22W (Retrofitted)
- CASNUB -22W(M)
- CASNUB -22NL
- CASNUB NLM
- CASNUB -22NLB
- CASNUB -22HS

The CASNUB bogie assembly consists of the following components:

- i. Wheel set with Cartridge Bearing
- ii. Adapter, retainer bolt & side frame key assembly
- iii. Side frames with friction plates
- iv. Bolster with wear liners
- v. Spring plank, fit bolts & rivets
- vi. Load bearing springs and snubber springs
- vii. Friction shoe wedges
- viii. Centre pivot arrangement comprising of Centre pivot top, Centre pivot Bottom, Centre pivot pin, Centre pivot retainer & locking arrangement
- ix. Side Bearers
- x. Elastomeric Pad
- xi. Bogie Brake Gear
- xii. Brake Beam

CASNUB bogie – Front view

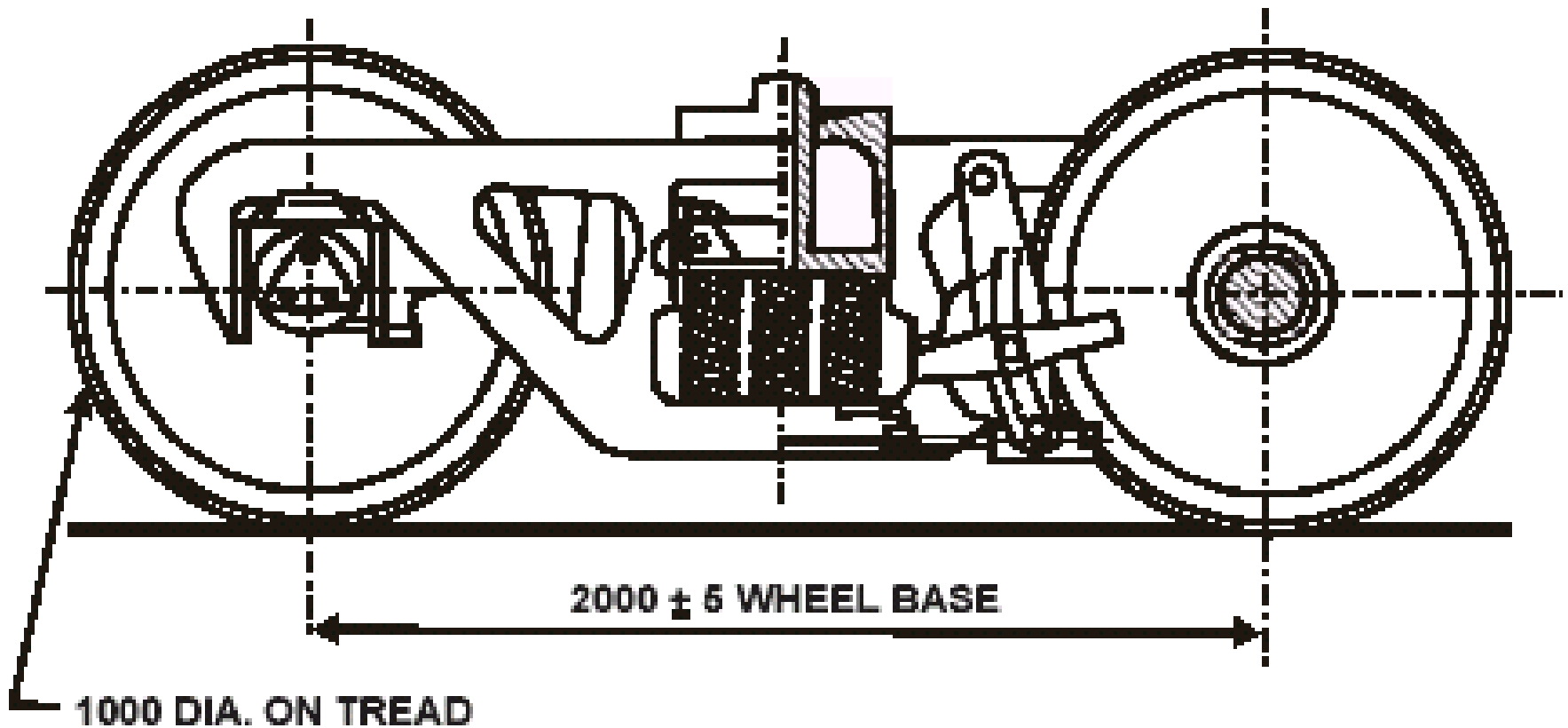

CASNUB bogie – top view

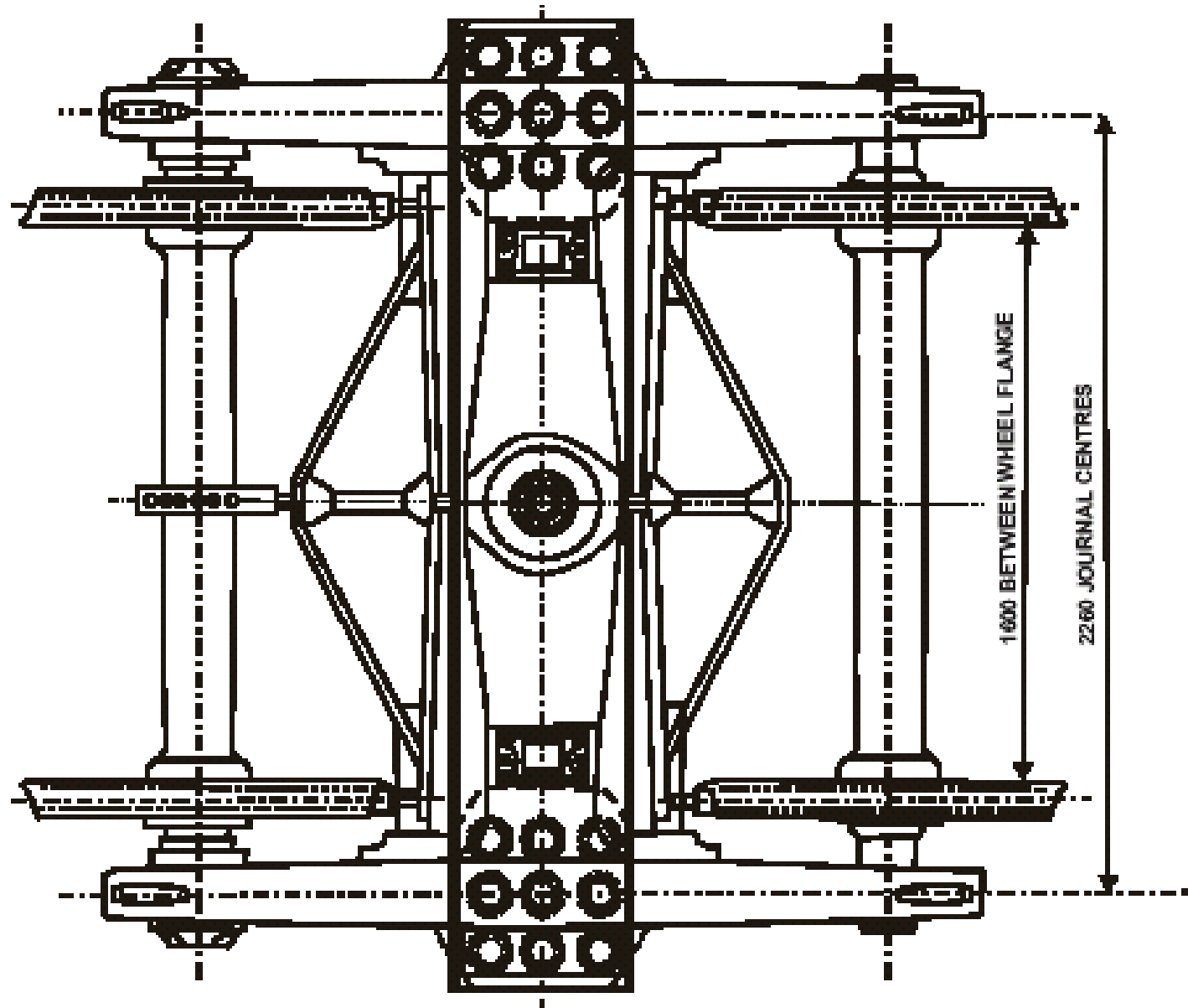

These bogies are now used in the following wagons:-

BOXN

BOBR

BCN

BOBRN

BCNA

BOBY

BRN

BOBYN

BTPN

BFK

BTPGLN

CASNUB –22W

- ❑ “wide jaw” category..
- ❑ The **adapter is not provided** with elastomeric pad (EM Pad) where the later versions are provided with EM pad.
- ❑ The shape of the **bolster at the bottom is straight** and centre pivot, known as IRS type, is fitted with the bolster. A simple straight pin is used to connect bolster with the body of the wagon through centre pivot.
- ❑ The side bearer is of “clearance type”. A **pair of rollers** is used with each bogie maintaining a nominal clearance with the body. Load is transferred to bolster only through centre pivot but not through side bearer while in motion on straight track. Side bearer share vertical load only during motion on curved track.

Contd--

CASNUB 22W contd..

The brake beam used in this version is known as “pocket type” or “sliding type”. The brake head is integral part of the brake beam and slides in the pocket provided in the side frame.

The disadvantages of this bogie are:

- Higher wheel wear
- Replacement of brake beam requires removal of wheel set
- Low stability as significant vertical load not shared by side bearer

Two types of 22 W -

Integral type centre pivot

Non integral type centre pivot

CASNUB –22W(M)

- This falls under wide jaw category same as 22W version. The major difference in the side frame as compared to 22W is provision of **negative camber** (sag at the middle of the side frame) to take care of maintaining same buffer height while **using EM pad**. EM pad has been introduced along with the adapter to reduce incidence of higher wheel wear as experienced with the 22W version.
- The bolster used with this bogie is same as that of 22W version. The only difference is that “spherical type” centre pivot is fitted with this bolster. Pin with castle nut and split pin is used to connect the bolster with the body of the wagon through the centre pivot.

Contd--

CASNUB –22W(M) contd--

- The side bearer used with this version is metal bonded EM pad maintaining constant contact with the body. This improves the stability of the wagon as compared 22W version.
- **Hanger type Brake beam** assembled with separate brake head through spring loaded brake shoe adjuster is used with this version. This has the advantage in replacing brake beam without running out of the wheel set. But this design has suffered set back due problem of **drooping of brake beam** and grazing of brake components. This design is discontinued in the later versions of the bogie.

CASNUB –22W(Retrofitted)

➤ This is basically 22W version incorporated with some of the better design aspect of 22W(M).

The main differences with 22W are:

Use of elastomeric pad with the adapter

Use of constant contact metal bonded elastomeric pad in side bearer housing

➤ To accommodate elastomeric pad and to maintain buffer height, the height of the adapter has been reduced. However, it is not possible to use higher diameter wheel set to maintain the buffer height. Wheel below the diameter of 956 mm is to be used with this version.

CASNUB –22NL

- “Narrow jaw” category. The side frame is modified to accommodate elastomeric pad similar to 22W(M) version and pocket to accommodate sliding type brake beam hanger similar to 22W version. The side bearer, centre pivot, bolster are similar to 22W(M) version.
- Centre pivot pin is locked by shackle lock unlike castle nut used in 22W(M) version.
- The adapter used with this version is of smaller size to suit to narrow jaw opening of the side frame.

CASNUB –22NLB

This version is similar to 22NL version, except for bolster. The shape of the bolster is “fish belly” at the centre to reduce the weight of bogie. However only a marginal weight reduction compared to NL type has been possible.

CASNUB –22NLM

- similar to NLB version in relation to dimensions of the components.
- The only difference is change in material of the side frame and bolster. The equivalent carbon % of side frame and bolster in NL/NLB is 0.85%. This has resulted in reduction of weight of the bogie compared to NL version.
- The weight of the NLM version bogie is 5.125 ton where as the weight of NL version is 5.5 ton.

CASNUB –22HS

- The CASNUB –22HS bogie has been developed for high- speed operation with maximum permitted speed up to 100 Kmph. The side frame, elastomeric pad, centre pivot, centre pivot lock, adapter are similar to NLB version.
- The bolster is mostly same as NLB type except for **outer gib opening and higher diameter spigot** for the spring seat. The outer gib opening has been increased to 241 mm from 234 mm as in case of NLB type.
- The side bearer used with this version is **spring loaded constant contact type**.

SPRING NEST

The spring nest in the secondary suspension used with this version is different to that of other version. The spring combination in different version of the bogies are given below:

Type of bogie	Axle load in ton	Outer spring	Inner spring	Snubber spring
CASNUB 22W/22WM/R etro/NL/NLB/ NLM	20.3	12	8	4
CASNUB – HS	20.3	14	12	4

SPRING NEST:

Each spring-nest arrangement should be as follows

	Outer	Inner	Snubber
22.9 t	7	5	2
20.3 t	6	4	2
HS	7	6	2

Features of CASNUB -25

- Wide jaw
- Outer -7, Inner -7, Snubber -2
- Flat type Center pivot
- Bolster cross section more
- Spring dia – more
- Axle dia – more
- Distance between liners - more

KEY WORDS

ADAPTER

thrust shoulder, Machine relief, Crown lugs, adapter height of the crown, height of the crown seat, gap between adapter side lugs, adapter sides

SIDE FRAME

side frame column, Side frame column-side , side-frame anti rotation lugs, Key-seat to pedestal crown roof , Pedestal crown-sides, Pedestal-sides, pedestal jaws

BOLSTER

Bolster slope surface, bolster land surface. rotation stop lug, bolster outer gib, bolster inner gib

ADAPTER

Check that adapter is free from **rocking effect** on the outer cup of CTRB while pressing under hand pressure. There must not be any sign groove or ridge that prevents proper seating on the bearing.

The in-service outer cup should have sign of uniform wear.

Wear at **thrust shoulder** be within 0.7 mm. Adapter can be rejected when “Adapter wear” gauge touches the periphery of the adapter at any point.

Adapter can be rejected when the depth of the “**Machine relief**” is less than 0.8 mm. It is rejected when the “Adapter wear” gauge touches the “Machine relief” depth.

Reject the adapter when the gap between the “**Crown lugs**” reaches to 164 from 156 mm for wide jaw type and to 163.5 mm from 155.5 mm for narrow jaw type.

Contd--

ADAPTER Contd--

Reject the **adapter height of the crown** wears by 3.5 mm.

Reject the adapter when **height of the crown seat** reduces to 45 mm from 48.5 mm for wider jaw, to 22 mm from 25.5 mm for modified wide jaw and to 22.7 mm from 26.2 mm for narrow jaw type.

Reject the adapter when the **gap between adapter side lugs** increases to 136 mm from 130 mm for wide jaw type and to 103 mm from 97 mm.

Reject the adapter when the distance between **adapter sides** reduces to 262 mm from 268 mm for wide jaw type and to 175 mm from 181 mm for narrow jaw type.

SIDE FRAME

- Side frame should be reclaimed in flowing conditions:
- Replace Si-Mn steel liners of side frame column reduce to 6 mm from 10 mm or when the liner is found crack/broken.
- Side frame column-side reaches to 206 mm from 216 mm.
- Gap between side-frame anti rotation lugs increase to 528 mm from 522 mm.
- Gap between Key-seat to pedestal crown roof increases to 278 mm from 272 mm for 22W type, to 323 mm from 318 mm for 22W(M) type and to 328 mm from 323 mm for NL type side frame.
- Pedestal crown-sides reduce to 144 mm from 152 mm.
- Pedestal-sides reduce to 101 mm from 105 mm for wide jaw type and to 77 mm from 81 mm for narrow jaw type.
- Gap between pedestal jaws increase to 278 mm from 270 mm for 22W type, to 286 mm from 278 mm for 22W(M) to 198 mm from 190 mm for NL/HS type.

BOLSTER:

Bolster should be reclaimed in flowing conditions:

Bolster slope surface liner thickness reduces to 3 mm from 8 mm.

Width of bolster land surface reduces to 438 mm from 444 mm.

Width of rotation stop lug reduces to 512 mm from 518 mm.

Gap between bolster outer gib increases to 244 mm from 234 mm for other than HS to 251mm from 241 mm for HS type.

Gap between bolster inner gib increases to 146 mm from 136 mm for other than HS type and to 146 mm from 136 mm for HS type.

SPRING

Reject the spring on the basis of free height in mm

	For HS		For Non-HS	
	Nominal	Condemn	Nominal	Condemn
OUTER	260	245	260	245
INNER	243	228	262	247
SNUBBER	293	278	294	279

The springs must have free height difference within 3 mm for assembling within a group.

AXLE

Reject the axle if the depth of notch (due to rubbing action of MPR) reaches to 5 mm.

Check the thread profile of axle-end holes with thread wear gauge.

Packing used to maintain buffer height

- 956 – 930mm - for 22WM, 22 HS, 22 NLB (female bogie) – 13 mm
- 930-906 mm – 37 mm
- For male bogie – 910 mm – 13 mm

S L	COMBINED DIMENSIONS Description for clearances	22 W 22 W (Retro)	22 W (M)	22 NL, NLB	22 HS
1	Lateral clearance between Side frame & Bolster	18 mm	18 mm	18 mm	25 mm.
2	Lateral clearance between Side frame & Adapter	25 mm.	25 mm.	16 mm.	16 mm.
3	Longitudinal clearance between Side frame & Adapter	2 mm.	10 mm.	9 mm.	9 mm.
4	Longitudinal clearance between Side frame & Bolster	6 mm.	6 mm.	6 mm.	6 mm.
5	Clearance between Anti- rotation lug & Bolster	4 mm.	4 mm.	4 mm.	4 mm.

END