

FUEL OIL SYSTEM OF GM-LOCOMOTIVE

**By S.JohnSaheb
Sr.Lecturer/DSL(Mech)
STC/SC**

FUEL OIL SYSTEM

WDG4



F/oil Tank
6000 lts

FUEL OIL SYSTEM OF GM LOCOMOTIVE

1. In operation the fuel from the fuel tank is drawn up by the fuel pump through a suction strainer, through primary fuel filters and is delivered to the engine mounted secondary spin on fuel filters.

2. It then passes through these filter elements into the fuel manifold supply line and then to each injector's internal inlet filter at each cylinder of the engine

Capacity-22.7lts/min



Fuel booster motor

Fuel suction strainer



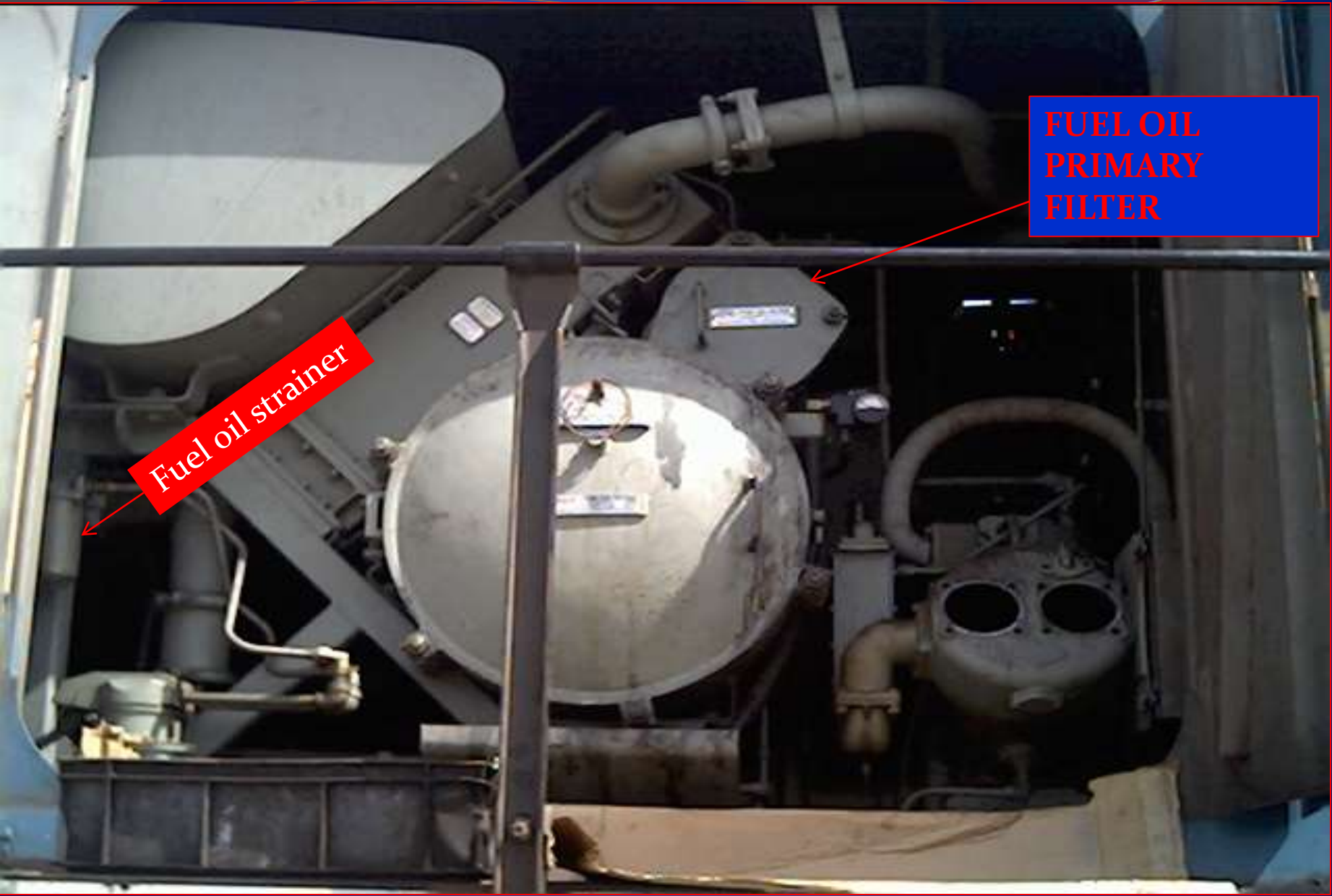

Fuel oil strainer

FUEL OIL
PRIMARY
FILTER

PRIMARY FUEL FILTER SINGLE CANISTER-TYPE

A canister-type primary fuel filter assembly is mounted on the equipment rack under the lube oil cooler assembly. Change the canister filter element at the intervals stated in the Scheduled Maintenance Program or more frequently, if operating conditions warrant.

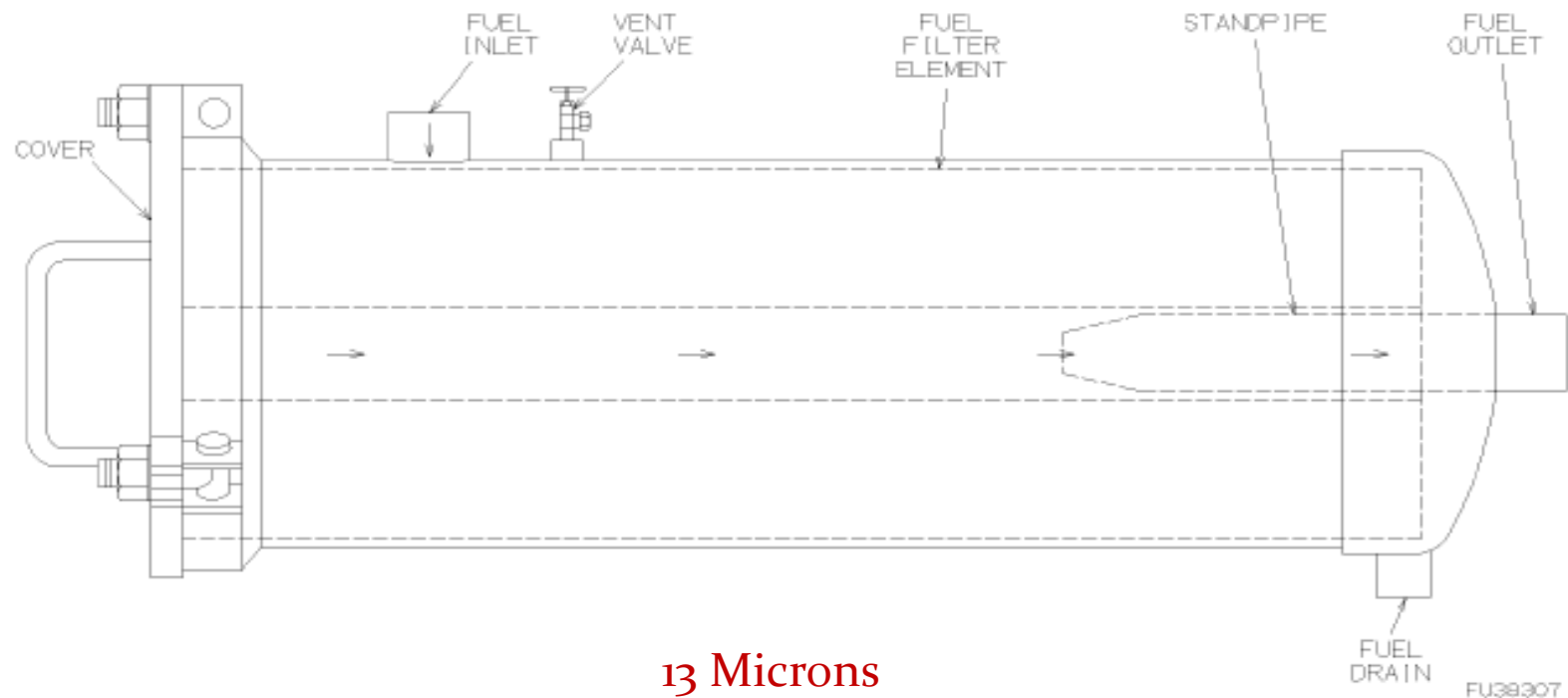

Figure 2-7 Single Canister - Primary Fuel Filter Assembly

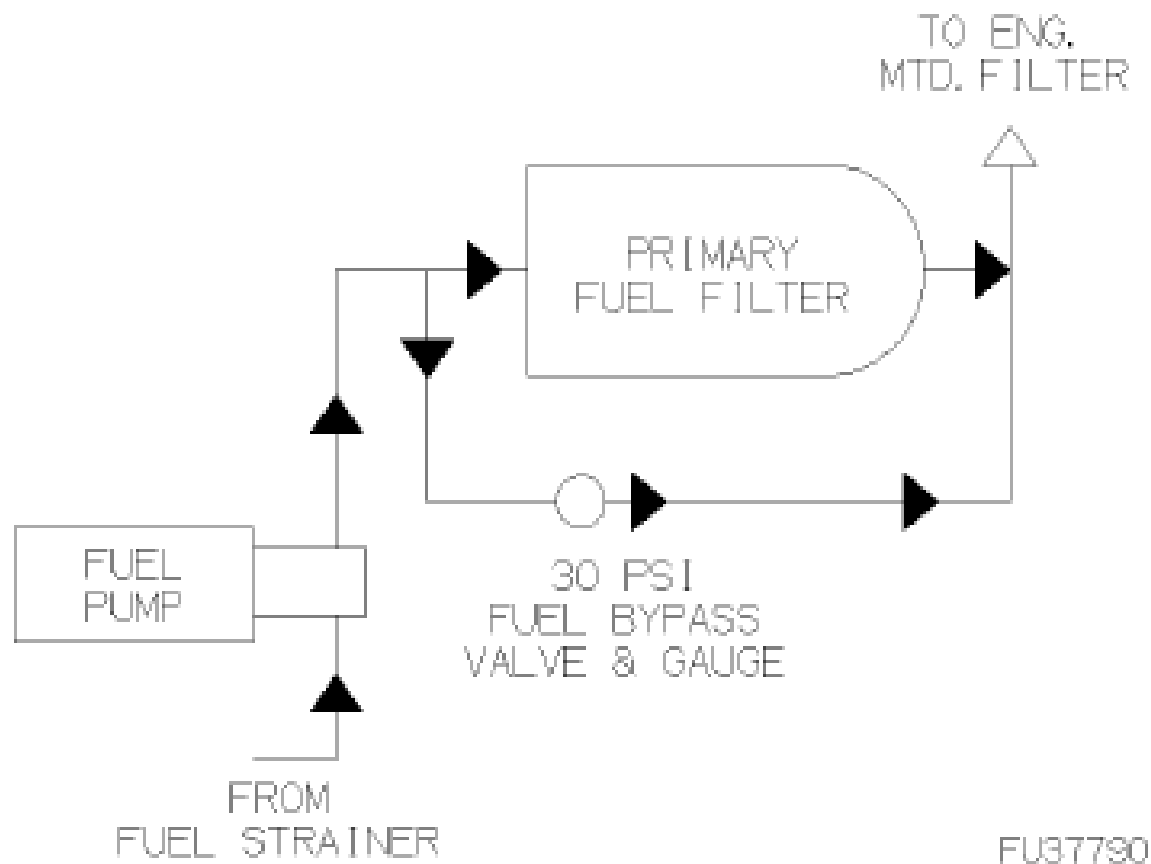
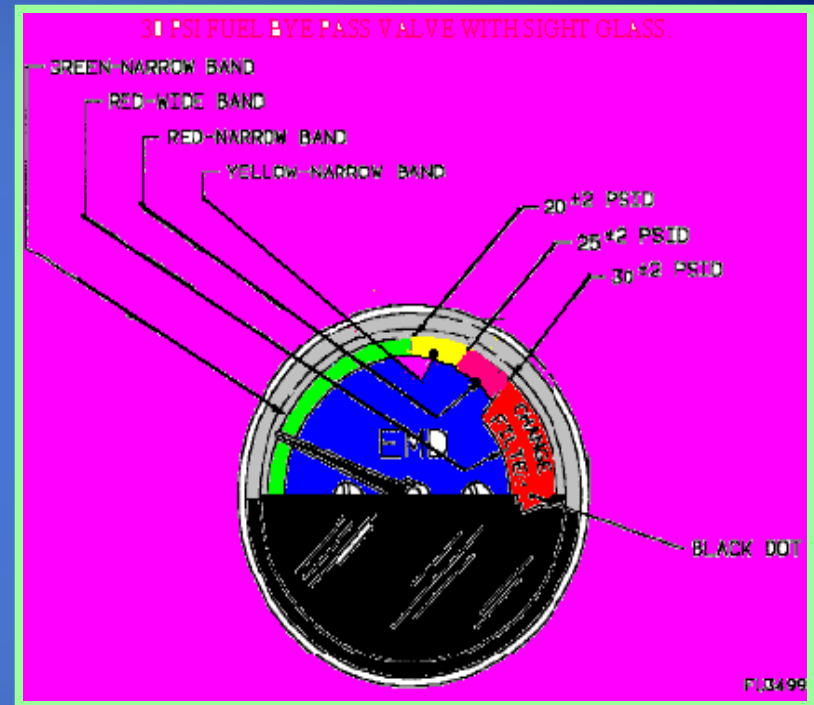

Figure 2-8 System Diagram: Single Canister - Primary Fuel Filter Assembly

The condition of the primary fuel filter. Increased pressure differential across the primary fuel filter will be indicated by a greater reading on the gauge. Normally, with new primary filters, the gauge should read in the green zone.

As the filter element becomes plugged, the indicator will read higher until it reaches the red CHANGE FILTER zone at approximately 30 psi (207 kPa) pressure differential.

At this point, the bypass valve will begin to open, allowing the fuel oil to bypass the primary fuel filter. Renew primary fuel



1. Manually advance injector control lever about 1/3 its travel

2. Turn the fuel prime/engine start switch (FP/ES) to ENGINE START position and hold the switch in this position until the engine fires and speed increases, but not for more than twenty (20) seconds.

**• CAUTION
Do not crank engine for more than twenty (20) seconds .**

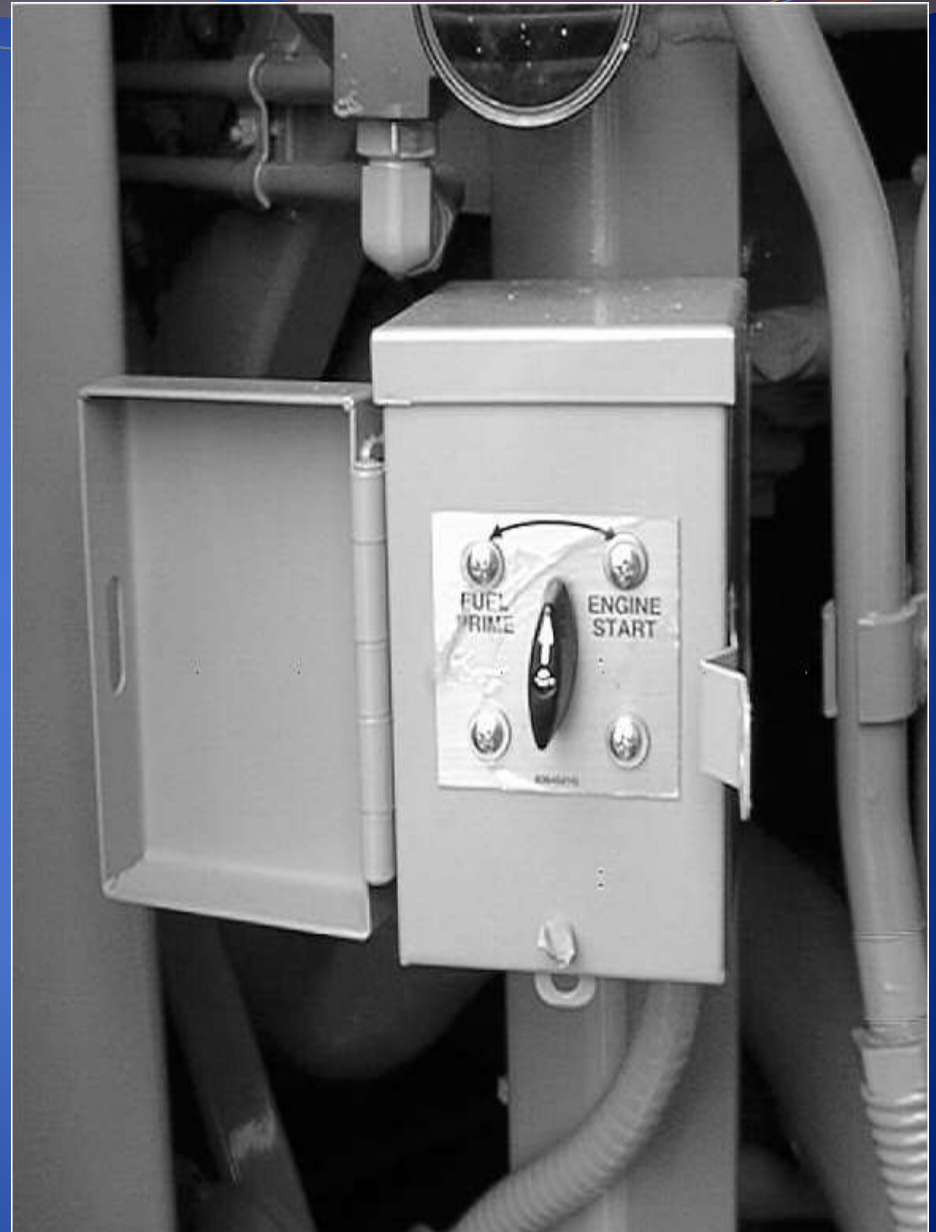

Secondary Filter No-1

1. When the fuel system is primed, turbulent flow will occur as evidenced by bubbles in the sight glass. When the fuel in the glass flows clear and free of bubbles.

2. The engine may be cranked. Upon engine start with governor-controlled engines, the return fuel sight glass will be empty.

3. Fuel flowing through the return fuel sight glass is the excess fuel that has circulated through the engine without being injected. Upon leaving the sight glass it returns to the fuel tank for recirculation.

SPIN-ON TYPE SECONDARY FILTER



10 PSI PRIMARY REGULATING VALVE WITH RETURN SIGHT GLASS (full during work)

60 PSI RELIEF VALVE WITH SIGHT GLASS

ENGINE MOUNT(Spin-On) FUEL FILTERS

- 1. Return Fuel Sight Glass (Normally Full)
- 2. Bypass Sight Glass (Normally Empty)
- 3. Filter Elements **2 to 5 Microns**

Secondary Filter No-2

1. The engine mounted filter is also equipped with a bypass relief valve and sight glass. This sight glass, farther from the engine, is normally empty.
2. When more than a trickle of fuel is seen in the bypass sight glass, it indicates that the relief valve is open.
3. Fuel will pass through the bypass sight glass and relief valve to bypass the engine and return to the fuel tank when the filter elements become clogged.
4. This condition may become serious and cause the engine to shut down from lack of fuel

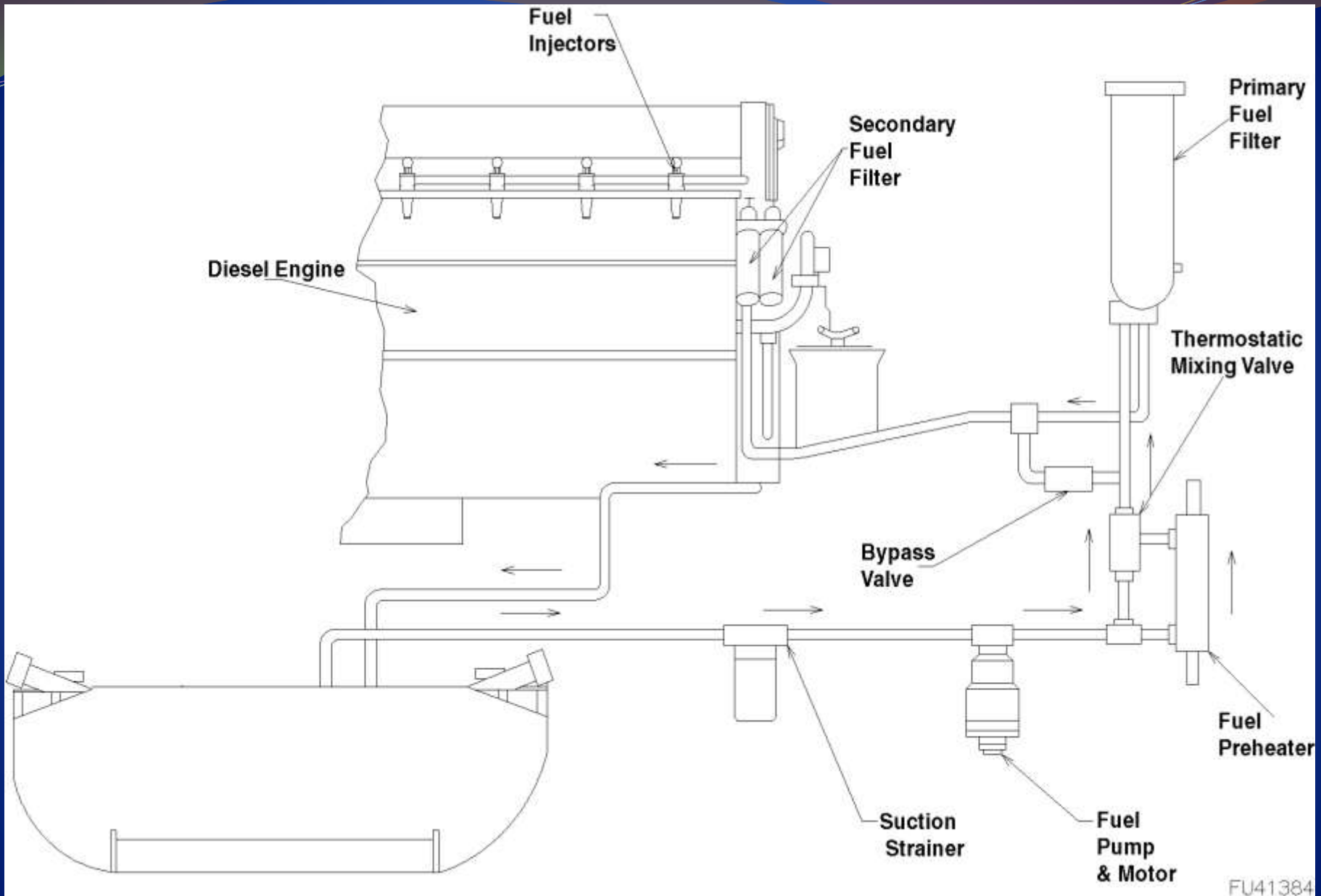

FU41384

FUEL OIL SYSTEM OF GM LOCO

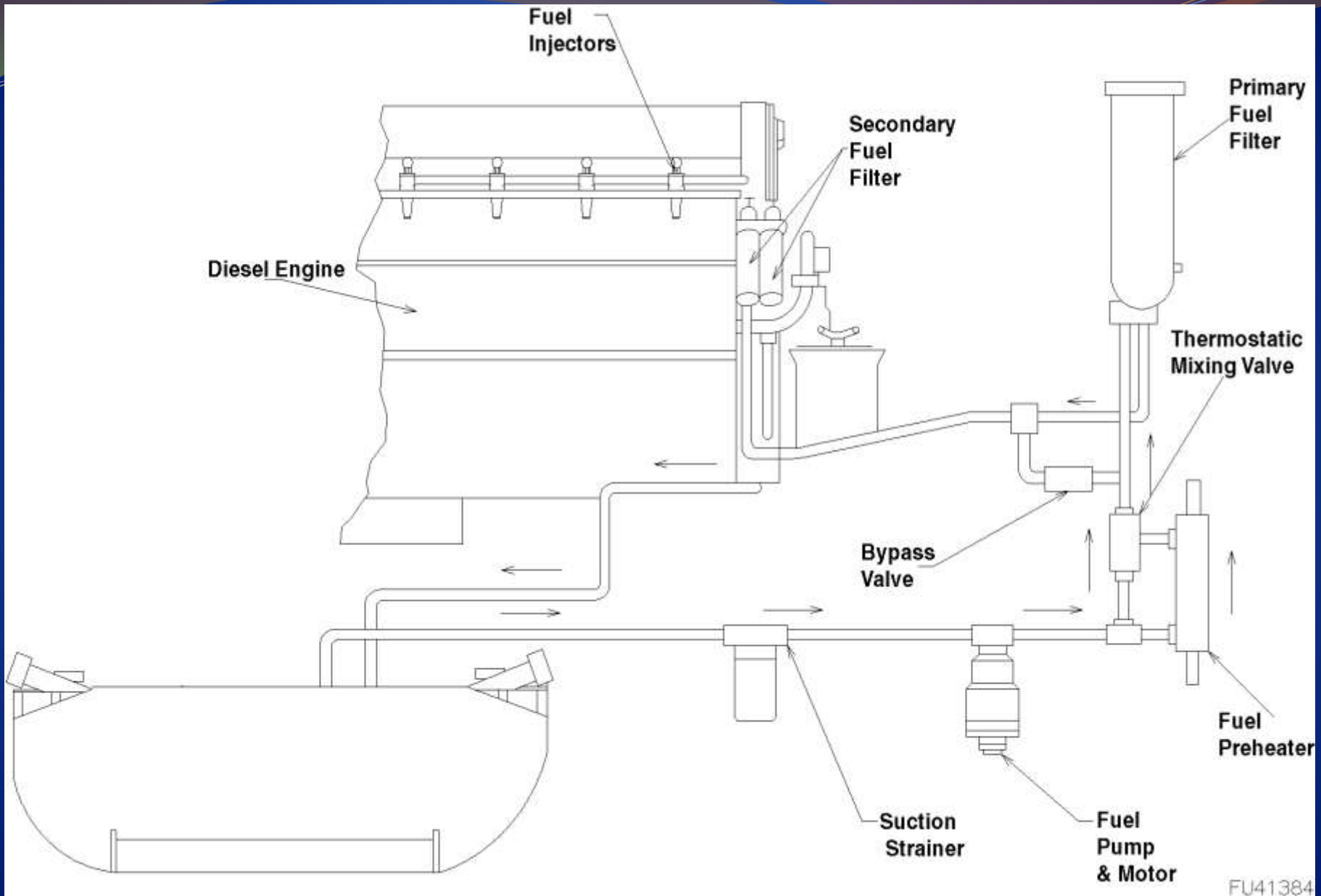

FU41384

FUEL OIL SYSTEM OF GM LOCO

FUEL OIL SYSTEM WDG4

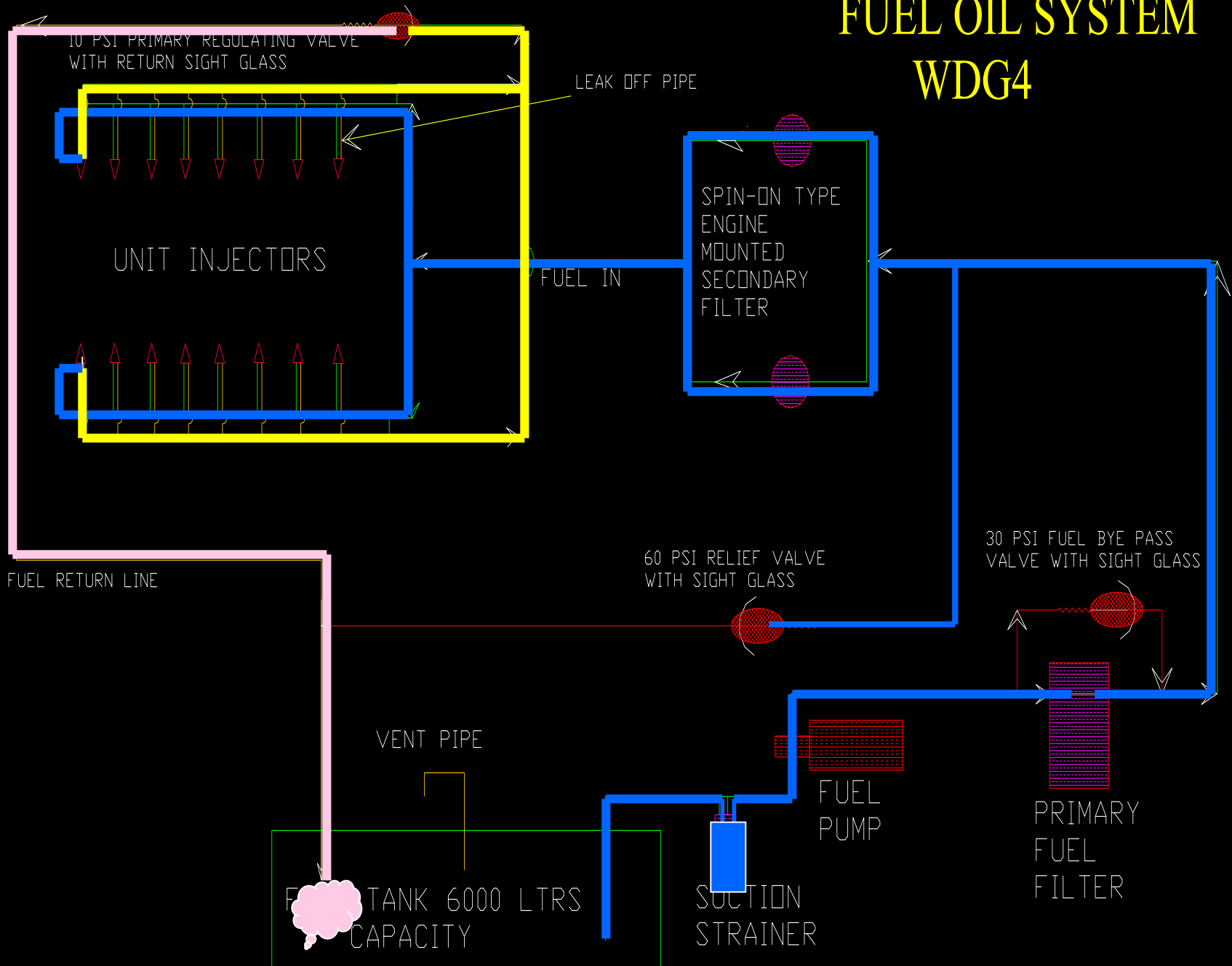

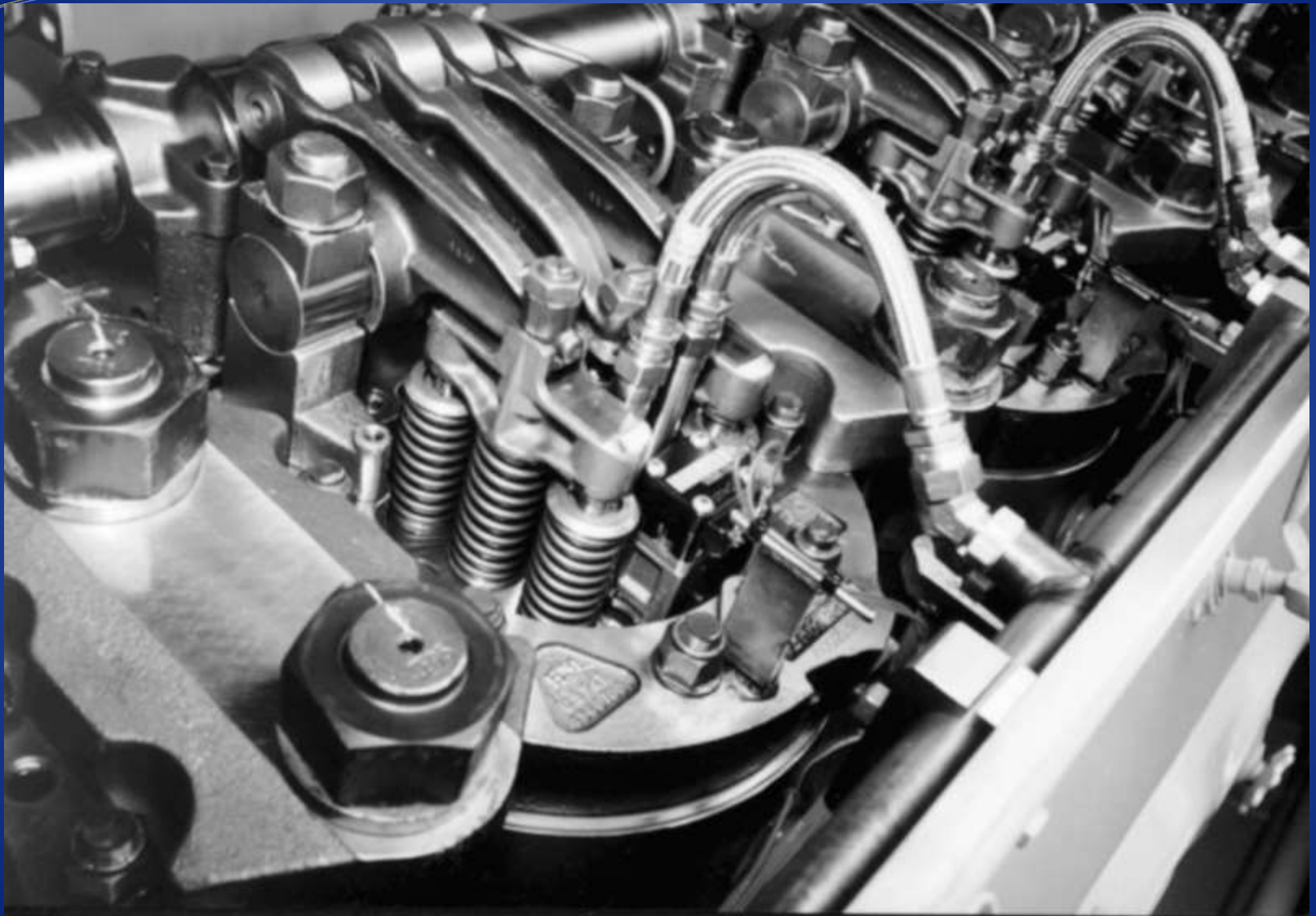

FUEL OIL SYSTEM WDG4

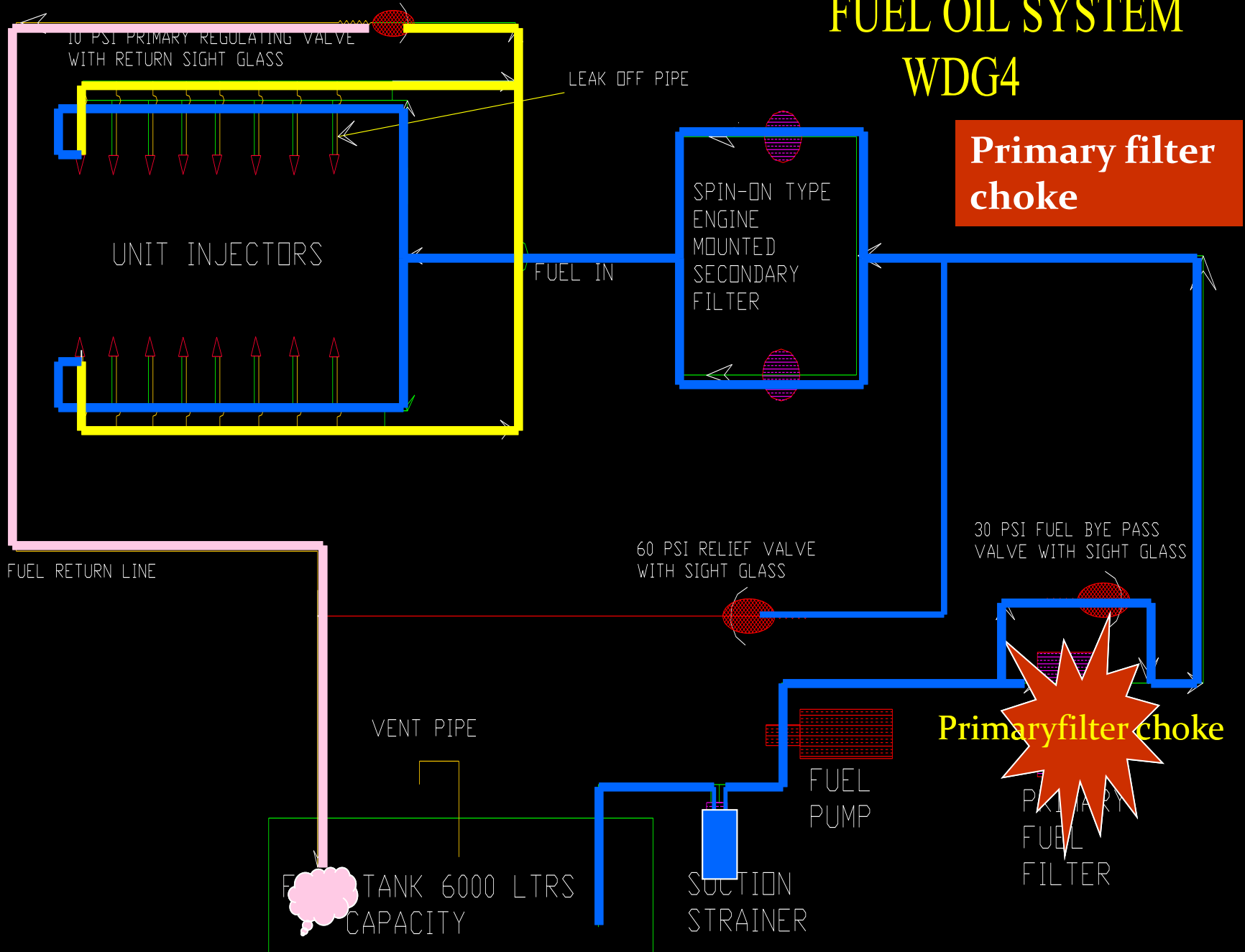

FUEL OIL SYSTEM

WDG4

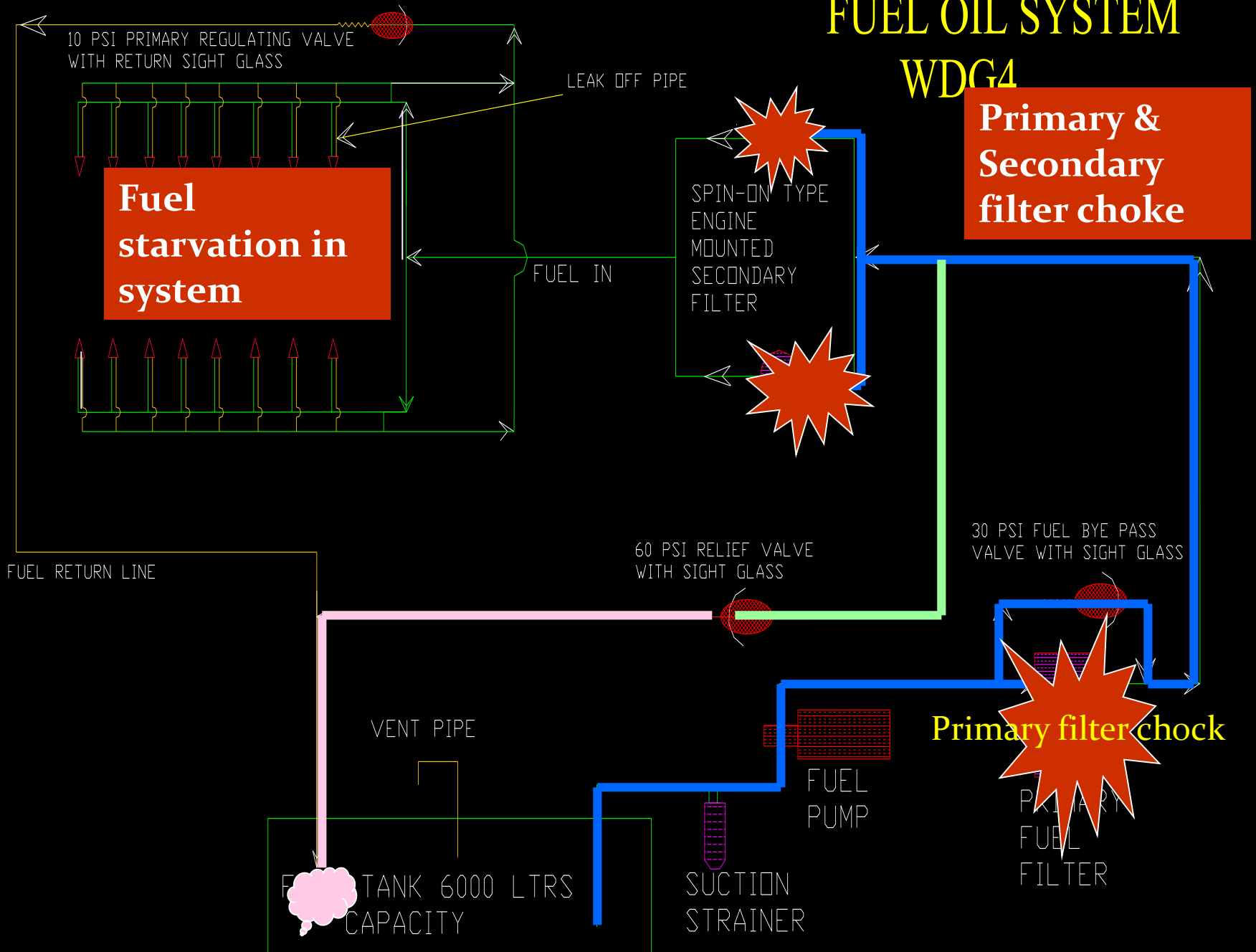

Fuel starvation in system

Primary & Secondary filter choke

Primary filter chock

10 PSI PRIMARY REGULATING VALVE WITH RETURN SIGHT GLASS

LEAK OFF PIPE

SPIN-ON TYPE ENGINE MOUNTED SECONDARY FILTER

FUEL IN

60 PSI RELIEF VALVE WITH SIGHT GLASS

30 PSI FUEL BYE PASS VALVE WITH SIGHT GLASS

FUEL RETURN LINE

VENT PIPE

FUEL TANK 6000 LTRS CAPACITY

SUCTION STRAINER

FUEL PUMP

PRIMARY FUEL FILTER

A cross-section of the MUI injector and names of the various parts are shown in Figure 11-3.

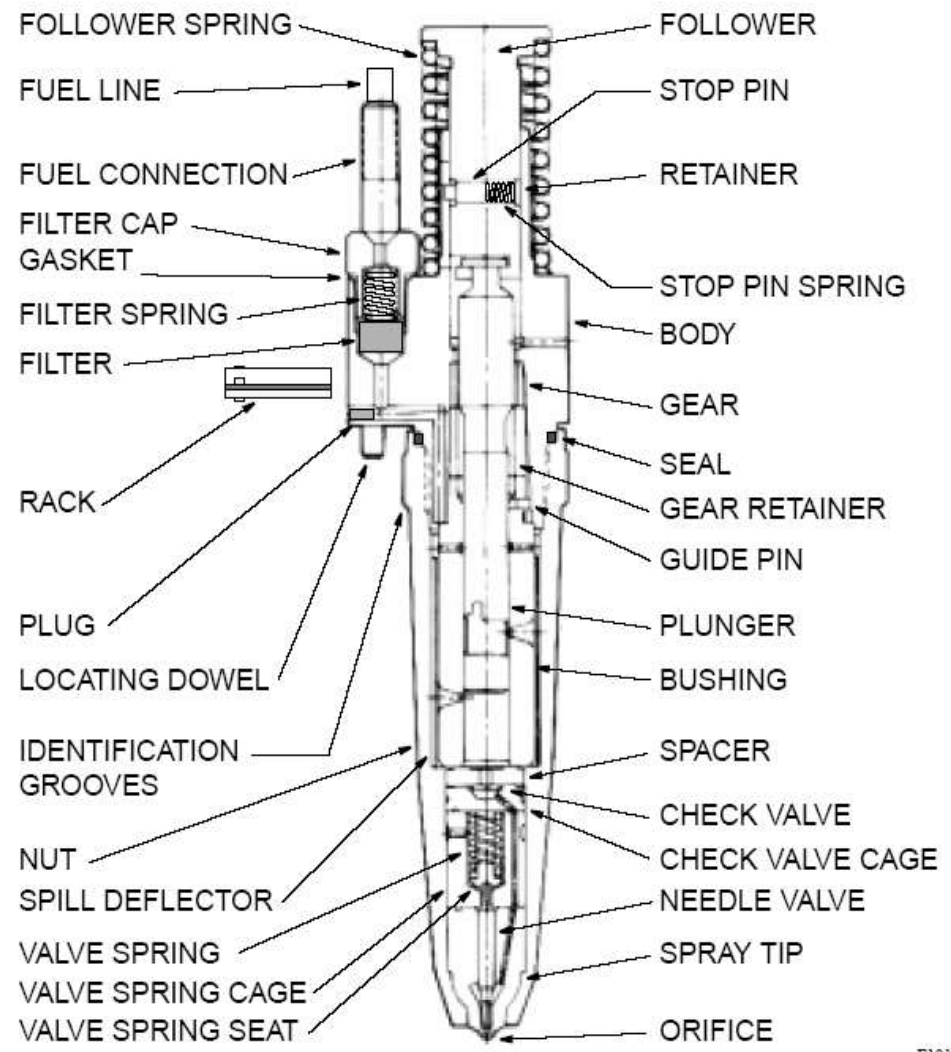

**Mechanical
fuel injector**

F10173

Figure 11-3. MUI Fuel Injector, Cross-Section .

A small portion of the fuel supplied to each injector is pumped at very high pressure through the check valve, to the needle valve, unseating it and allowing fuel flow out of the injector.

Forcing the fuel through the spray tip results in fuel atomization in the cylinder.

The quantity of fuel injected depends upon the position of the plunger helix as set by the injector rack and governor.

Any excess fuel not used by the injector flows through the fuel return line to the check valve in the return fuel sight glass.

This check valve restricts the return fuel flow, maintaining a back pressure on the injectors.

The fuel continues to flow through the check valve into the return fuel sight glass and then to the fuel supply tank.

The constant flow of fuel through the injectors serves to lubricate and cool the injectors.



***Mechanical
fuel injector***

SCHEDULES

MONTHLY:-

- *Cleaning of fuel suction strainer.
- * Draining of condensate from fuel tank & checking for any leaks.
- *Visual check of any fuel leaks in top deck, examination of all linkages.

90/180 DAYS:-

- * Renewing fuel primary and secondary spin on filters.
- *Checking the torque value of fuel line bolts.
- *Examination of fuel booster pump gears for any scoring or damage.

YEARLY/2 YEARLY:-

- *Renewing sight glass gaskets. Checking fuel relief valve and bye pass valves on test stand.
- *Checking and renewing defective sight glass clevis clamps.
- *Cleaning fuel tank glow rod gauges and renewing 'O-rings.
- *Overhauling fuel pump, testing on test stand and refitting.

3 YEARLY:-

- *Overhauling all fuel injectors and refitting.
- *Renewing worn out rack linkage bearings and pins.