

CHAPTER 5

Learning Objectives

Generator Principal
Simple Loop Generator
Practical Generator
Yoke
Pole Cores and Pole Shoes
Pole Coils
Armature Core
Armature Windings
Bushes and Bearings
Pole-pitch
Conductor-Coil and
Winding Element
Coil-span or Coil-pitch
Pitch of a Winding
Back Pitch
Front Pitch
Resultant Pitch
Commutator Pitch
Single-layer Winding
Two-layer Winding
Degree of Re-entrancy of
an Armature Winding
Multiplex Winding
Lap and Wave Winding
Simplex-lap Winding
Numbering of Coils and
Commutator Segments
Simplex Wave Winding
Dummy or Idle Coils
Uses of Lap and Wave
Windings
Types of Generators
Brush Contact Drop
Generated E.M.F. or E.M.F.
Equation of a Generator Iron
Loss in Armature
Total loss in a D.C.
Generator
Stray Losses
Constant or Standing
Losses
Power Stages
Condition for Maximum
Efficiency

D.C. GENERATORS



● Generator converts mechanical energy into electrical energy using electromagnetic induction

Generator Principle

An electrical generator is a machine which converts mechanical energy (or power) into electrical energy (or power).

The energy conversion is based on the principle of the production of dynamically (or motionally) induced e.m.f. As seen from Fig. 26.1, whenever a conductor cuts magnetic flux, dynamically induced e.m.f. is produced in it according to Faraday's Laws of Electromagnetic Induction. This e.m.f. causes a current to flow if the conductor circuit is closed.

Hence, two basic essential parts of an electrical generator are (i) a magnetic field and (ii) a conductor or conductors which can so move as to cut the flux.

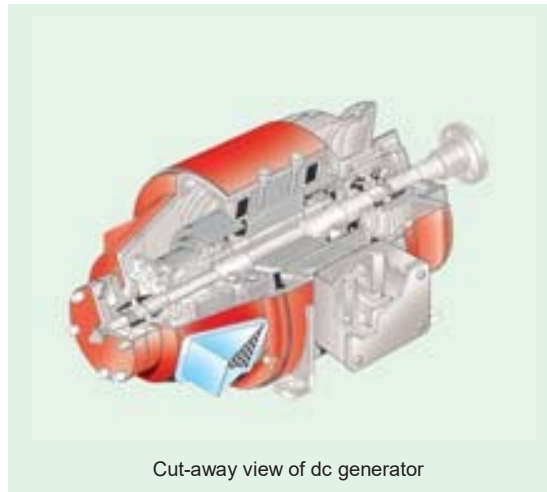

Simple Loop Generator

Construction

In Fig. 26.1 is shown a single-turn rectangular copper coil $ABCD$ rotating about its own axis in a magnetic field provided by either permanent magnet is or electromagnets. The two ends of the coil

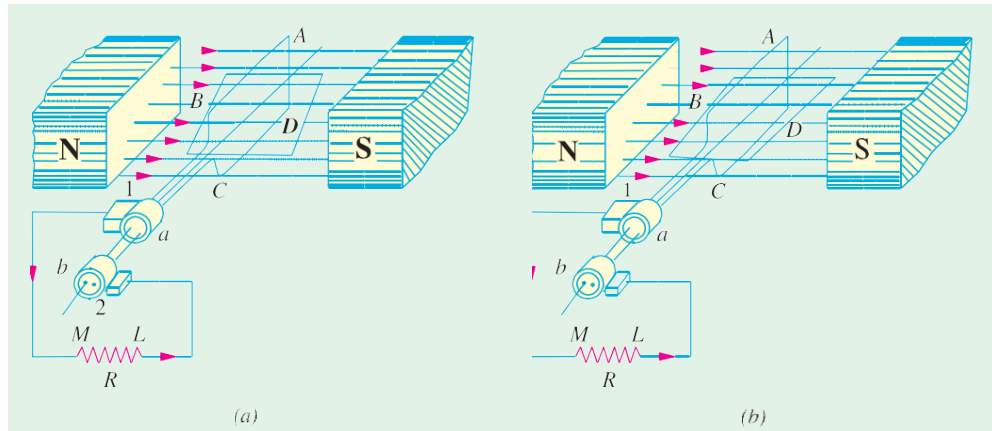

Fig. 26.1

are joined to two slip-rings 'a' and 'b' which are insulated from each other and from the central shaft. Two collecting brushes (of carbon or copper) press against the slip-rings. Their function is to collect the current induced in the coil and to convey it to the external load resistance R .

The rotating coil may be called 'armature' and the magnets as 'field magnets'.

Working

Imagine the coil to be rotating in clock-wise direction (Fig. 26.2). As the coil assumes successive positions in the field, the flux linked with it changes. Hence, an e.m.f. is induced in it which is

proportional to the rate of change of flux linkages ($e = Nd\Phi/dt$). When the plane of the coil is at right angles to lines of flux *i.e.* when it is in position, 1, then flux linked with the coil is maximum but **rate of change of flux linkages is minimum.**

It is so because in this position, the coil sides *AB* and *CD* do not cut or shear the flux, rather they slide along them *i.e.* they move parallel to them. Hence, there is no induced e.m.f. in the coil. Let us take this no-e.m.f. or vertical position of the coil as the starting position. The angle of rotation or time will be measured from this position.

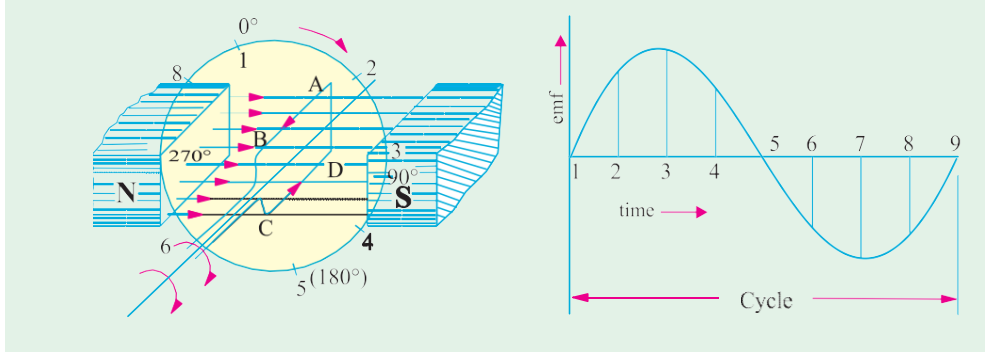

Fig. 26.2

Fig. 26.3

As the coil continues rotating further, the rate of change of flux linkages (and hence induced e.m.f. in it) increases, till position 3 is reached where $\theta = 90^\circ$. Here, the coil plane is horizontal *i.e.* parallel to the lines of flux. As seen, the flux linked with the coil is minimum but **rate of change of flux linkages is maximum.** Hence, maximum e.m.f. is induced in the coil when in this position (Fig. 26.3).

In the next quarter revolution *i.e.* from 90° to 180° , the flux linked with the coil gradually **increases** but the rate of change of flux linkages **decreases**. Hence, the induced e.m.f. decreases gradually till in position 5 of the coil, it is reduced to zero value.

So, we find that in the first half revolution of the coil, no (or minimum) e.m.f. is induced in it when in position 1, maximum when in position 3 and no e.m.f. when in position 5. The direction of this induced e.m.f. can be found by applying Fleming's Right-hand rule which gives its direction from *A* to *B* and *C* to *D*. Hence, the direction of current flow is **ABMLCD** (Fig. 26.1). The current through the load resistance *R* flows from *M* to *L* during the first half revolution of the coil.

In the next half revolution *i.e.* from 180° to 360° , the variations in the magnitude of e.m.f. are similar to those in the first half revolution. Its value is maximum when coil is in position 7 and minimum when in position 1. But it will be found that the direction of the induced current is from *D* to *C* and *B* to *A* as shown in Fig. 26.1 (b). Hence, the path of current flow is along **DCLMBA** which is just the reverse of the previous direction of flow.

Therefore, we find that the current which we obtain from such a simple generator reverses its direction after every half revolution. Such a current undergoing periodic reversals is known as alternating current. It is, obviously, different from a direct current which continuously flows in one and the same direction. It should be noted that alternating current not only reverses its direction, it does not even keep its magnitude constant while flowing in any one direction. The two half-cycles may be called positive and negative half-cycles respectively (Fig. 26.3).

For making the flow of current unidirectional in the **external** circuit, the slip-rings are replaced by split-rings (Fig. 26.4). The split-rings are made out of a conducting cylinder which is cut into two halves or segments insulated from each other by a thin sheet of mica or some other insulating material (Fig. 26.5).

As before, the coil ends are joined to these segments on which rest the carbon or copper brushes.

It is seen [Fig. 26.6 (a)] that in the first half revolution current flows along *(ABMNLCD)* i.e. the brush No. 1 in contact with segment 'a' acts as the positive end of the supply and 'b' as the negative end. In the next half revolution [Fig. 26.6 (b)], the direction of the induced current in the coil has reversed. But at the same time, the positions of segments 'a' and 'b' have also reversed with the

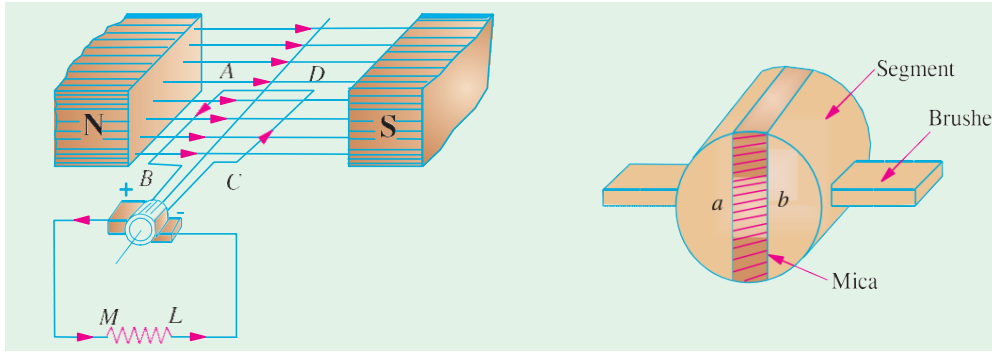

Fig. 26.4

Fig. 26.5

result that brush No. 1 comes in touch with the segment which is positive i.e. segment 'b' in this case. Hence, current in the load resistance again flows from *M* to *L*. The waveform of the current through the external circuit is as shown in Fig. 26.7. *This current is unidirectional but not continuous like pure direct current.*

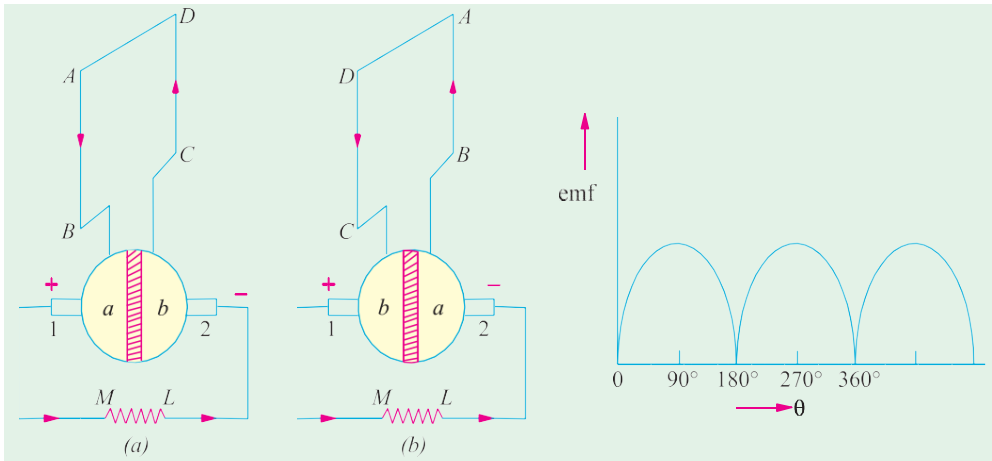

Fig. 26.6

Fig. 26.7

It should be noted that the position of brushes is so arranged that the change over of segments 'a' and 'b' from one brush to the other takes place when the plane of the rotating coil is at right angles to the plane of the lines of flux. It is so because in that position, the induced e.m.f. in the coil is zero.

Another important point worth remembering is that even now the current induced in the coil sides is alternating as before. It is only due to the rectifying action of the split-rings (also called commutator) that it becomes unidirectional in the external circuit. Hence, it should be clearly understood that even in the armature of a d.c. generator, the induced voltage is alternating.

Practical Generator

The simple loop generator has been considered in detail merely to bring out the basic principle

underlying construction and working of an actual generator illustrated in Fig. 26.8 which consists of the following essential parts :

- | | |
|------------------------------------|------------------------------|
| 1. Magnetic Frame or Yoke | 2. Pole-Cores and Pole-Shoes |
| 3. Pole Coils or Field Coils | 4. Armature Core |
| 5. Armature Windings or Conductors | 6. Commutator |
| 7. Brushes and Bearings | |

Of these, the yoke, the pole cores, the armature core and air gaps between the poles and the armature core or the magnetic circuit whereas the rest form the electrical circuit.

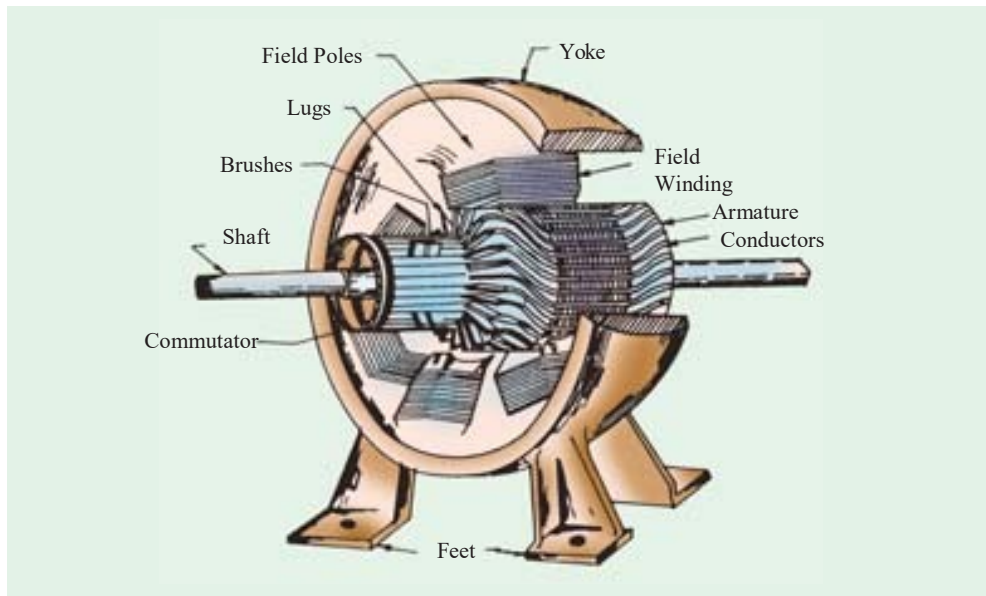

Fig. 26.8

Yoke

The outer frame or yoke serves double purpose :

- (i) It provides mechanical support for the poles and acts as a protecting cover for the whole machine and
- (ii) It carries the magnetic flux produced by the poles.

In small generators where cheapness rather than weight is the main consideration, yokes are made of cast iron. But for large machines usually cast steel or rolled steel is employed. The modern process of forming the yoke consists of rolling a steel slab round a cylindrical mandrel and then welding it at the bottom. The feet and the terminal box etc. are welded to the frame afterwards. Such yokes possess sufficient mechanical strength and have high permeability.



Yoke

Pole Cores and Pole Shoes

The field magnets consist of pole cores and pole shoes. The pole shoes serve two purposes

(i) they spread out the flux in the air gap and also, being of larger cross-section, reduce the reluctance of the magnetic path (ii) they support the exciting coils (or field coils) as shown in Fig. 26.14.

There are two main types of pole construction.

(a) The pole core itself may be a solid piece made out of either cast iron or cast steel but the pole shoe is laminated and is fastened to the pole face by means of counter sunk screws as shown in Fig. 24.10.

(b) In modern design, the complete pole cores and pole shoes are built of thin laminations of annealed steel which are rivetted together under hydraulic pressure (Fig. 26.11). The thickness of laminations varies from 1 mm to 0.25 mm. The laminated poles may be secured to the yoke in any of the following two ways:

- (i) Either the pole is secured to the yoke by means of screws bolted through the yoke and into the pole body or
- (ii) The holding screws are bolted into a steel bar which passes through the pole across the plane of laminations (Fig. 26.12).

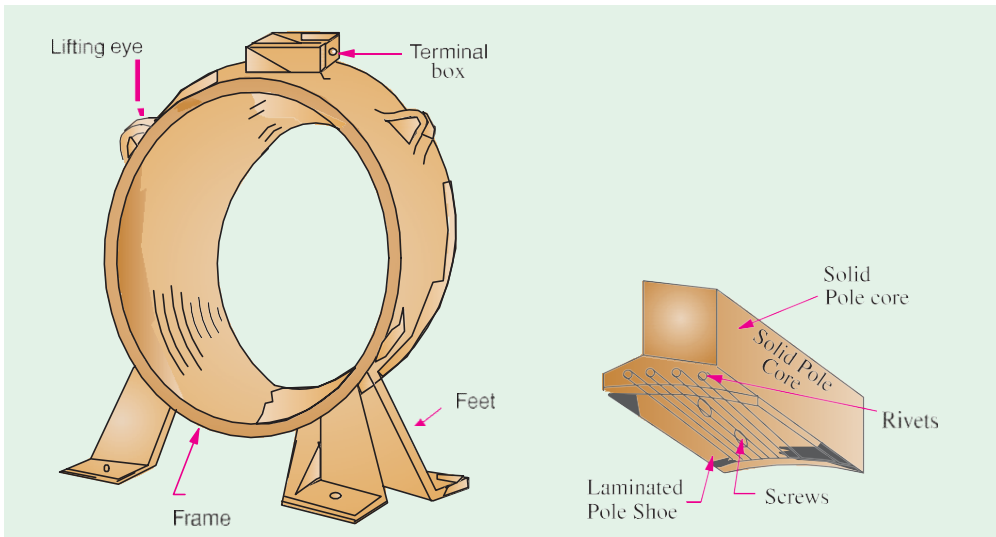

Fig. 26.9

Fig. 26.10

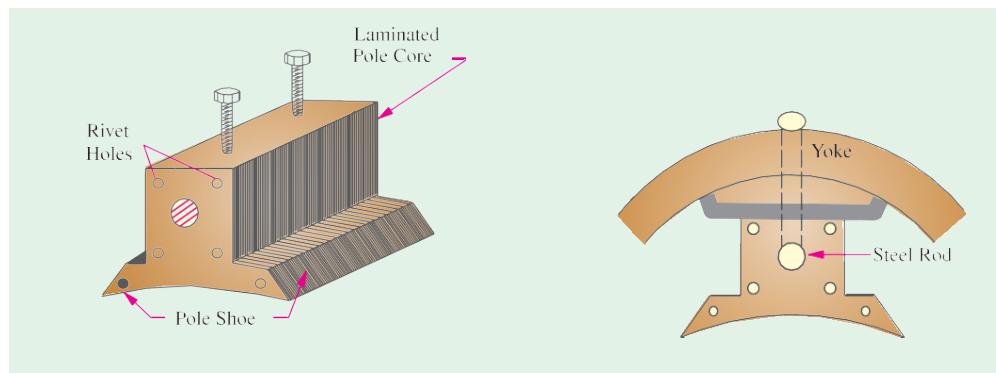

Fig. 26.11

Fig. 26.12

Pole Coils

The field coils or pole coils, which consist of copper wire or strip, are former-wound for the correct dimension (Fig. 26.13). Then, the former is removed and wound coil is put into place over the core as shown in Fig. 26.14.

When current is passed through these coils, they electromagnetise the poles which produce the necessary flux that is cut by revolving armature conductors.

Armature Core

It houses the armature conductors or coils and causes them to rotate and hence cut the magnetic flux of the field magnets. In addition to this, its most important function is to provide a path of very low reluctance to the flux through the armature from a *N*-pole to a *S*-pole.

It is cylindrical or drum-shaped and is built up of usually circular sheet steel discs or laminations approximately 0.5 mm thick (Fig. 26.15). It is keyed to the shaft.

The slots are either die-cut or punched on the outer periphery of the disc and the keyway is located on the inner diameter as shown. In small machines, the armature stampings are keyed directly to the shaft. Usually, these laminations are perforated for air ducts which permits axial flow of air through the armature for cooling purposes. Such ventilating channels are clearly visible in the laminations shown in Fig. 26.16 and Fig. 26.17.

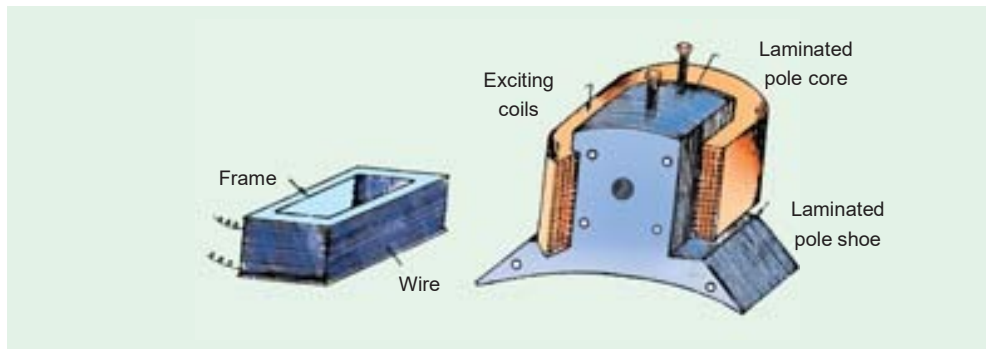

Fig. 26.13

Fig. 26.14

Up to armature diameters of about one metre, the circular stampings are cut out in one piece as shown in Fig. 26.16. But above this size, these circles, especially of such thin sections, are difficult to handle because they tend to distort and become wavy when assembled together. Hence, the circular laminations, instead of being cut out in one piece, are cut in a number of suitable sections or segments which form part of a complete ring (Fig. 26.17).

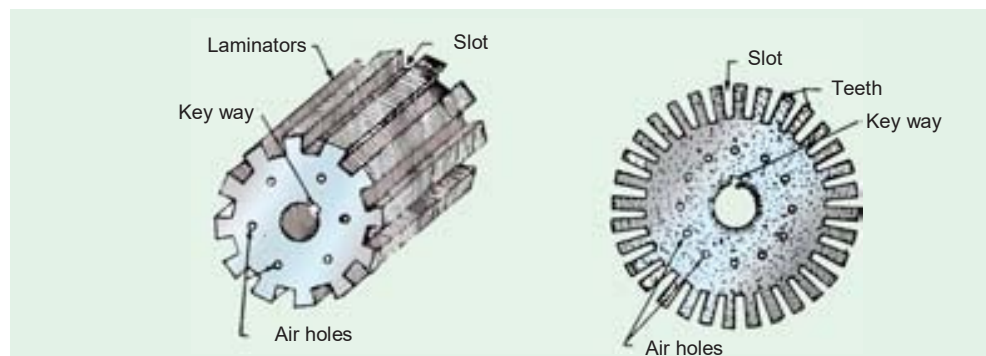

Fig. 26.15

Fig. 26.16

A complete circular lamination is made up of four or six or even eight segmental laminations. Usually, two keyways are notched in each segment and are dove-tailed or wedge-shaped to make the laminations self-locking in position.

The purpose of using laminations is to reduce the loss due to eddy currents. Thinner the laminations, greater is the resistance offered to the induced e.m.f., smaller the current and hence lesser the $I^2 R$ loss in the core.

Armature Windings

The armature windings are usually former-wound. These are first wound in the form of flat rectangular coils and are then pulled into their proper shape in a coil puller. Various conductors of the coils are insulated from each other. The conductors are placed in the armature slots which are lined with tough insulating material. This slot insulation is folded over above the armature conductors placed in the slot and is secured in place by special hard wooden or fibre wedges.

Commutator

The function of the commutator is to facilitate collection of current from the armature conductors. As shown in Art. 26.2, it rectified *i.e.* converts the alternating current induced in the armature conductors into unidirectional current in the external load circuit. It is of cylindrical structure and is built up of wedge-shaped segments of high-conductivity hard-drawn or drop forged copper. These

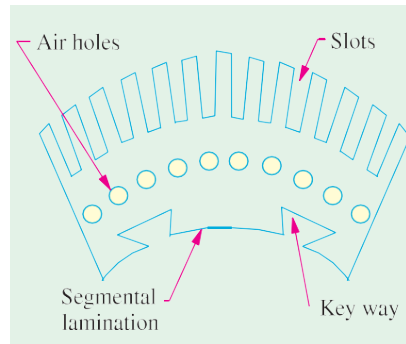

Fig. 26.17

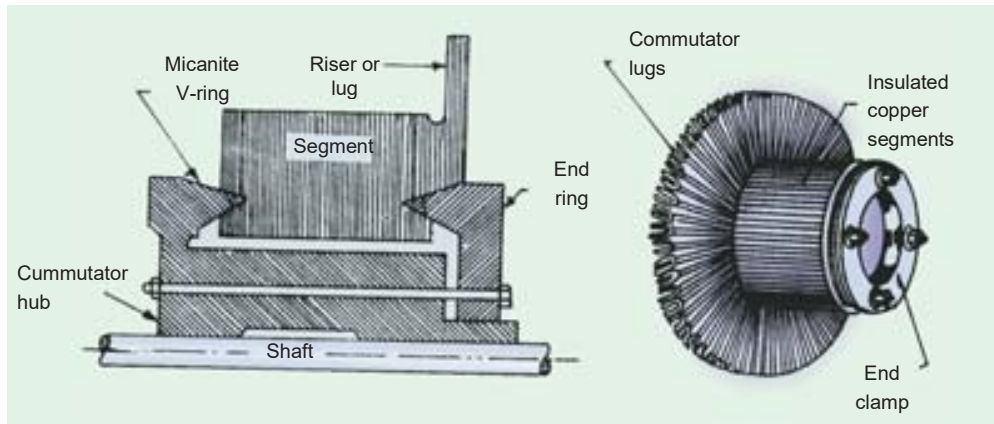

Fig. 26.18

Fig. 26.19

segments are insulated from each other by thin layers of mica. The number of segments is equal to the number of armature coils. Each commutator segment is connected to the armature conductor by means of a copper lug or strip (or riser). To prevent them from flying out under the action of centrifugal forces, the segments have V-grooves, these grooves being insulated by conical micanite rings. A sectional view of commutator is shown in Fig. 26.18 whose general appearance when completed is shown in Fig. 26.19.

Brushes and Bearings

The brushes whose function is to collect current from commutator, are usually made of carbon or

graphite and are in the shape of a rectangular block. These brushes are housed in brush-holders usually of the box-type variety. As shown in Fig. 26.20, the brush-holder is mounted on a spindle and the brushes can slide in the rectangular box open at both ends. The brushes are made to bear down on the commutator by a spring whose tension can be adjusted by changing the position of lever in the notches. A flexible copper pigtail mounted at the top of the brush conveys current from the brushes to the holder. The number of brushes per spindle depends on the magnitude of the current to be collected from the commutator.

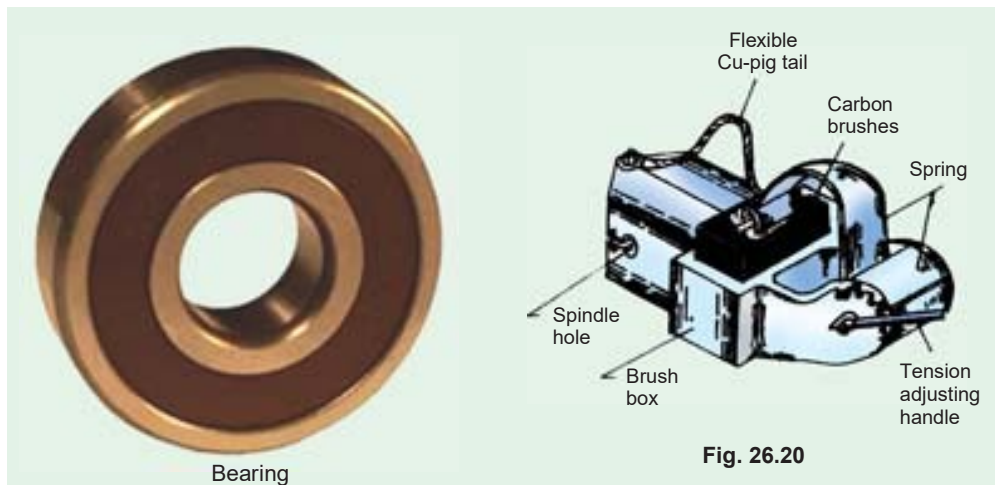

Because of their reliability, ball-bearings are frequently employed, though for heavy duties, roller bearings are preferable. The ball and rollers are generally packed in hard oil for quieter operation and for reduced bearing wear, sleeve bearings are used which are lubricated by ring oilers fed from oil reservoir in the bearing bracket.

Armature Windings

Now, we will discuss the winding of an actual armature. But before doing this, the meaning of the following terms used in connection with armature winding should be clearly kept in mind.

Pole-pitch

It may be variously defined as :

- (i) The periphery of the armature divided by the number of poles of the generator *i.e.* the distance between two adjacent poles.
- (ii) It is equal to the number of armature conductors (or armature slots) per pole. If there are 48 conductors and 4 poles, the pole pitch is $48/4 = 12$.



Conductor

The length of a wire lying in the magnetic field and in which an e.m.f. is induced, is called a conductor (or inductor) as, for example, length *AB* or *CD* in Fig. 26.21.

Coil and Winding Element

With reference to Fig. 26.21, the two conductors AB and CD along with their end connections constitute one coil of the armature winding. The coil may be single-turn coil (Fig. 26.21) or multi-turn coil (Fig. 26.22). A single-turn coil will have two conductors. But a multi-turn coil may have many conductors per coil side. In Fig. 26.22, for example, each coil side has 3 conductors. The

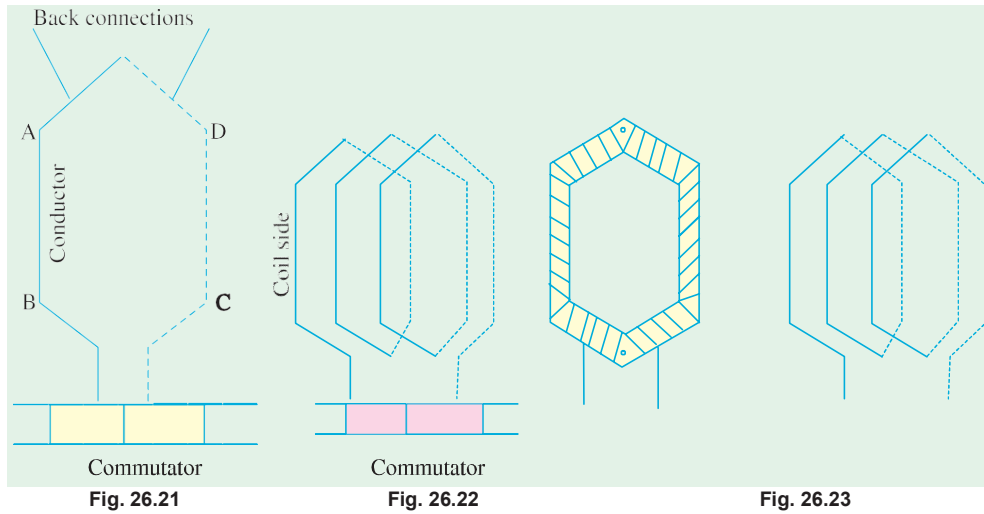

group of wires or conductors constituting a coil side of a multi-turn coil is wrapped with a tape as a unit (Fig. 26.23) and is placed in the armature slot. It may be noted that since the beginning and the end of each coil must be connected to a commutator bar, there are as many commutator bars as coils for both the lap and wave windings (see Example 26.1).

The side of a coil (1-turn or multiturn) is called a winding element. Obviously, the number of winding elements is twice the number of coils.

Coil-span or Coil-pitch (Y_s)

It is the distance, measured in terms of armature slots (or armature conductors) between two sides of a coil. It is, in fact, the periphery of the armature spanned by the two sides of the coil.

If the pole span or coil pitch is equal to the pole pitch (as in the case of coil A in Fig. 26.24 where pole-pitch of 4 has been assumed), then winding is called **full-pitched**. It means that coil span is 180 electrical degrees. In this case, the coil sides lie under opposite poles, hence the induced e.m.f.s. in them are additive. Therefore, maximum e.m.f. is induced in the coil as a whole, it being the sum of the e.m.f.s induced in the two coil sides. For example, if there are 36 slots and 4 poles, then coil span is $36/4 = 9$ slots. If number of slots is 35, then $Y_s = 35/4 = 8$ because it is customary to drop fractions.

If the coil span is less than the pole pitch (as in coil B where coil pitch is $3/4$ th of the pole pitch), then the

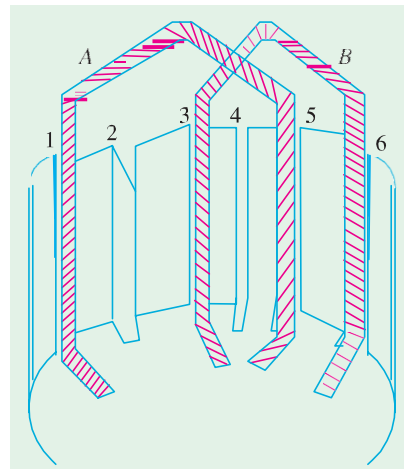

Fig. 26.24

winding is fractional-pitched. In this case, there is a phase difference between the e.m.fs. in the two sides of the coil. Hence, the total e.m.f. round the coil which is the vector sum of e.m.fs. in the two coil sides, is less in this case as compared to that in the first case.

Pitch of a Winding (Y)

In general, it may be defined as the distance round the armature between two successive conductors which are directly connected together. Or, it is the distance between the beginnings of two consecutive turns.

$$\begin{aligned}
 Y &= Y_B - Y_F \dots\dots\dots \text{for lap winding} \\
 &= Y_B + Y_F \dots\dots\dots \text{for wave winding}
 \end{aligned}$$

In practice, coil-pitches as low as eight-tenths of a pole pitch are employed without much serious reduction in the e.m.f. Fractional-pitched windings are purposely used to effect substantial saving in the copper of the end connections and for improving commutation.

Back Pitch (Y_B)

The distance, measured in terms of the armature conductors, which a coil advances on the back of the armature is called back pitch and is denoted by Y_B.

As seen from Fig. 26.28, element 1 is connected on the back of the armature to element 8. Hence, Y_B = (8 - 1) = 7.

Front Pitch (Y_F)

The number of armature conductors or elements spanned by a coil on the front (or commutator end of an armature) is called the front pitch and is designated by Y_F. Again in Fig. 26.28, element 8 is connected to element 3 on the front of the armature, the connections being made at the commutator segment. Hence, Y_F = 8 - 3 = 5.

Alternatively, the front pitch may be defined as the distance (in terms of armature conductors) between the second conductor of one coil and the first conductor of the next coil which are connected together at the front *i.e.* commutator end of the armature. Both front and back pitches for lap and wave-winding are shown in Fig. 26.25 and 26.26.

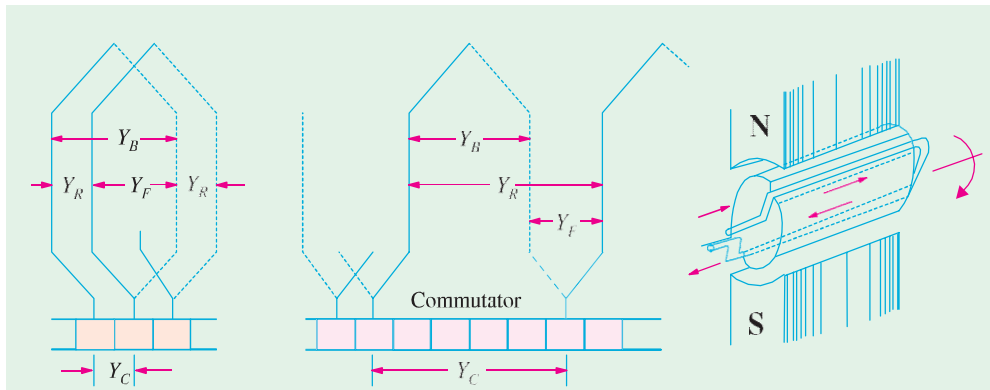

Fig. 26.25

Fig. 26.26

Fig. 26.27

Resultant Pitch (Y_R)

It is the distance between the beginning of one coil and the beginning of the next coil to which it is connected (Fig. 26.25 and 26.26).

As a matter of precaution, it should be kept in mind that all these pitches, though normally

stated in terms of armature conductors, are also sometimes given in terms of armature slots or commutator bars because commutator is, after all, an image of the winding.

Commutator Pitch (Y_C)

It is the distance (measured in commutator bars or segments) between the segments to which the two ends of a coil are connected. From Fig. 26.25 and 26.26 it is clear that for lap winding, Y_C is the *difference* of Y_B and Y_F whereas for wavewinding it is the *sum* of Y_B and Y_F . Obviously, commutator pitch is equal to the number of bars between coil leads. In general, Y_C equals the ‘plex’ of the lap-wound armature. Hence, it is equal to 1, 2, 3, 4 etc. for simplex-, duplex, triplex- and quadruplex etc. lap-windings.

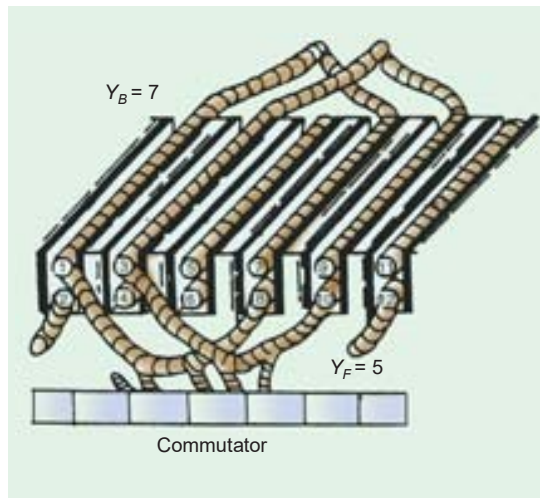

Fig. 26.28

Single-layer Winding

It is that winding in which one conductor or one coil side is placed in each armature slot as shown in Fig. 26.27. Such a winding is not much used.

Two-layer Winding

In this type of winding, there are two conductors or coil sides per slot arranged in two layers. Usually, one side of every coil lies in the upper half of one slot and other side lies in the lower half of some other slot at a distance of approximately one pitch away (Fig. 26.28). The transfer of the coil from one slot to another is usually made in a radial plane by means of a peculiar bend or twist at the back end as shown in Fig. 26.29. Such windings in which two coil sides occupy each slot are most commonly used for all medium-sized machines. Sometimes 4 or 6 or 8 coil sides are used in each slot in several layers because it is not practicable to have too many slots (Fig. 26.30). The coil sides lying at the upper half of the slots are numbered odd *i.e.* 1, 3, 5, 7 etc. while those at the lower half are numbered even *i.e.* 2, 4, 6, 8 etc.

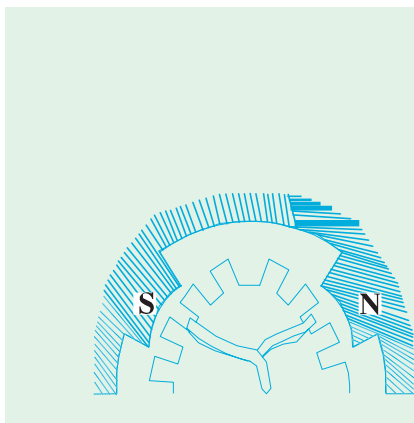

Fig. 26.29

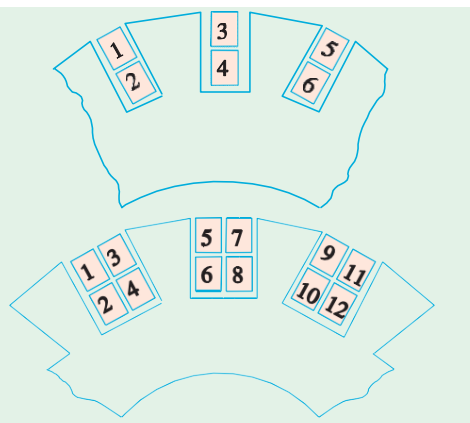

Fig. 26.30

Degree of Re-entrant of an Armature Winding

A winding is said to be single re-entrant if on tracing through it once, all armature conductors are included on returning to the starting point. It is double re-entrant if only half the conductors are included in tracing through the winding once and so on.

Multiplex Winding

In such windings, there are several sets of completely closed and independent windings. If there is only one set of closed winding, it is called simplex wave winding. If there are two such windings on the same armature, it is called duplex winding and so on. The multiplicity affects a number of parallel paths in the armature. For a given number of armature slots and coils, as the multiplicity increases, the number of parallel paths in the armature increases thereby increasing the current rating but decreasing the voltage rating.



Multiplex Winding

Lap and Wave Windings

Two types of windings mostly employed for drum-type armatures are known as Lap Winding and Wave Winding. The difference between the two is merely due to the different arrangement of the end connections at the front or commutator end of armature. Each winding can be arranged progressively or retrogressively and connected in simplex, duplex and triplex. The following rules, however, apply to both types of the windings:

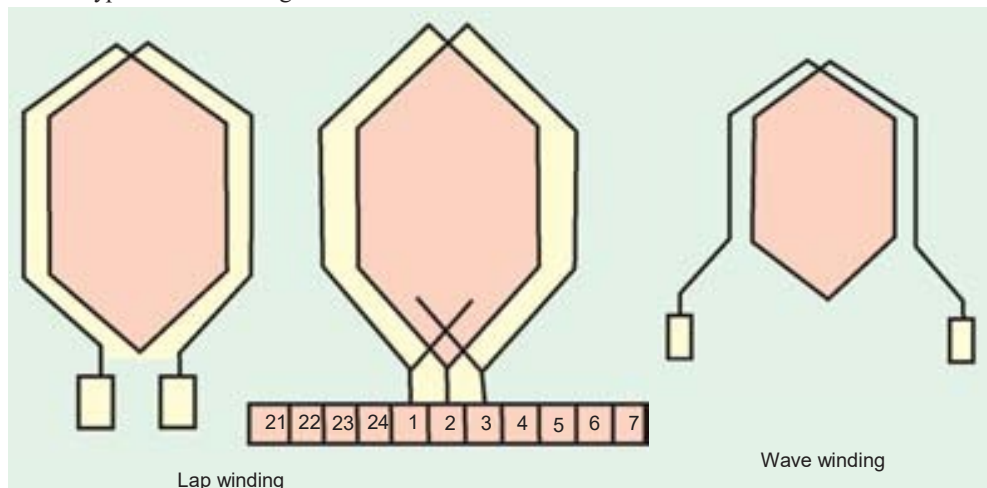

- (i) The front pitch and back pitch are each approximately equal to the pole-pitch *i.e.* windings should be full-pitched. This results in increased e.m.f. round the coils. For special purposes, fractional-pitched windings are deliberately used (Art. 26.15).
- (ii) Both pitches should be odd, otherwise it would be difficult to place the coils (which are former-wound) properly on the armature. For example, if Y_B and Y_F were both even, the *all* the coil sides and conductors would lie either in the upper half of the slots or in the lower

half. Hence, it would become impossible for one side of the coil to lie in the upper half. Hence, it would become impossible for one side of the coil to lie in the upper half of one slot and the other side of the same coil to lie in the lower half of some other slot.

- (iii) The number of commutator segments is equal to the number of slots or coils (or half the number of conductors) because the front ends of conductors are joined to the segments in pairs.
- (iv) The winding must close upon itself *i.e.* if we start from a given point and move from one coil to another, then all conductors should be traversed and we should reach the same point again without a break or discontinuity inbetween.

Simplex Lap-winding*

It is shown in Fig. 26.25 which employs single-turn coils. In lap winding, the finishing end of one coil is connected to a commutator segment and to the starting end of the adjacent coil situated under the same pole and so on, till and the coils have been connected. This type of winding derives its name from the fact it doubles or laps back with its succeeding coils.

Following points regarding simplex lap winding should be carefully noted :

1. The back and front pitches are odd and of opposite sign. But they cannot be equal. They differ by 2 or some multiple thereof.
2. Both Y_B and Y_F should be nearly equal to a pole pitch.
3. The average pitch $Y_A = \frac{Y_B + Y_F}{2}$. It equals pole pitch $= \frac{Z}{P}$.
4. Commutator pitch $Y_C = \pm 1$. (In general, $Y_C = \pm m$)
5. Resultant pitch Y_R is even, being the arithmetical difference of two odd numbers, *i.e.*, $Y_R = Y_B - Y_F$.
6. The number of slots for a 2-layer winding is equal to the number of coils (*i.e.* half the number of coil sides). The number of commutator segments is also the same.

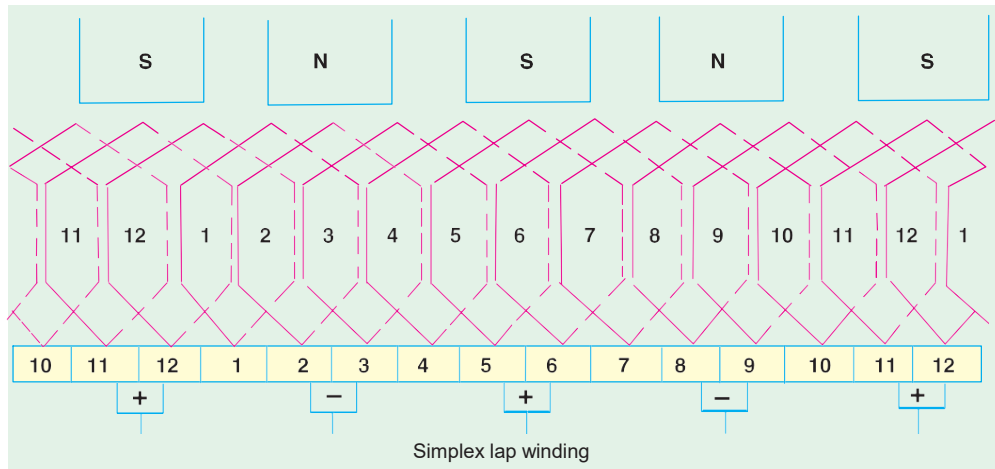

* However, where heavy currents are necessary, duplex or triplex lap windings are used. The duplex lap winding is obtained by placing two similar windings on the same armature and connecting the even-numbered commutator bars to one winding and the odd-numbered ones to the second winding. Similarly, in triplex lap winding, there would be three windings, each connected to one third of the commutator bars.

21 to (21 + 9) = 30	→	30 to (20 - 7) = 23
23 to (23 + 9) = 32	→	32 to (32 - 7) = 25
25 to (25 + 9) = 34 = (34 - 32) = 2	→	2 to (34 - 7) = 27
27 to (27 + 9) = 36 = (36 - 32) = 4	→	4 to (36 - 7) = 29
29 to (29 + 9) = 38 = (38 - 32) = 6	→	6 to (38 - 7) = 31
31 to (31 + 9) = 40 = (40 - 32) = 8	→	8 to (40 - 7) = 33 = (33 - 32) = 1

The winding ends here because we come back to the conductor from where we started.

We will now discuss the developed diagram which is one that is obtained by imagining the armature surface to be removed and then laid out flat so that the slots and conductors can be viewed without the necessity of turning round the armature in order to trace out the armature windings. Such a developed diagram is shown in Fig. 26.31.

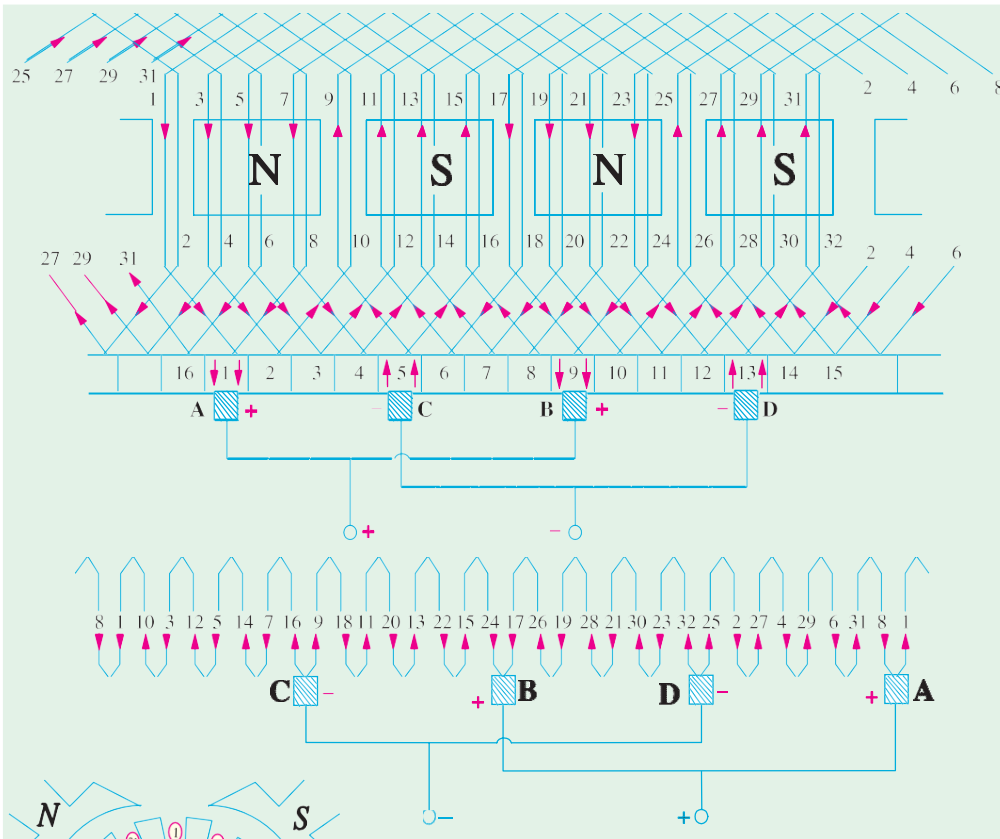

Fig. 26.31

The procedure of developing the winding is this :

Front end of the upper side of coil No. 1 is connected to a commutator segment (whose number is also 1). The back end is joined at the back to the $1 + 9 = 10$ th coil side in the lower half of 5th slot. The front end of coil side 10 is joined to commutator segment 2 to which is connected the front end of $10 - 7 = 3$ i.e. 3rd coil side lying in the upper half of second armature slot. In this way, by travelling 9 coil sides to the right at the back and 7 to the left at the

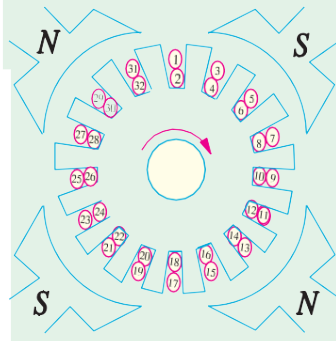

Fig. 26.32

front we complete the winding, thus including every coil side once till we reach the coil side 1 from where we started. Incidentally, it should be noted that all upper coil sides have been given odd numbers, whereas lower ones have been given even numbers as shown in the polar diagram (Fig. 26.32) of the winding of Fig. 26.31.

Brush positions can be located by finding the direction of currents flowing in the various conductors. If currents in the conductors under the influence of a N -pole are assumed to flow downwards (as shown), then these will flow upwards in conductors under the influence of S -pole. By putting proper arrows on the conductors (shown separately in the equivalent ring diagram), it is found that commutator bars No. 1 and 9 are the meeting points of e.m.f.s. and hence currents are flowing out of these conductors. The positive brushes should, therefore, be placed at these commutator bars. Similarly, commutator bars No. 5 and 13 are the separating points of e.m.f.s. hence negative brushes are placed there. In all, there are four brushes, two positive and two negative. If brushes of the same polarity are connected together, then all the armature conductors are divided into four parallel paths.

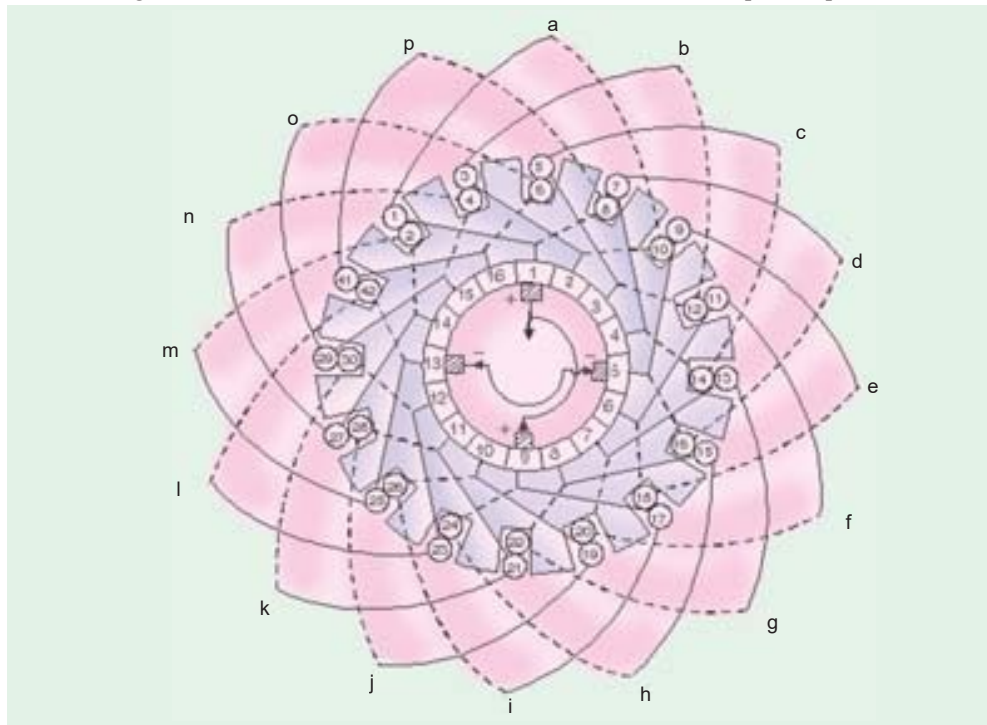

Fig. 26.33

Division of conductors into parallel paths is shown separately in the schematic diagram of Fig. 26.34. Obviously, if I_a is the total current supplied by the generator, then current carried by each parallel path is $I_a/4$.

Summarizing these conclusions, we have

1. The total number of brushes is equal to the number of poles.
2. There are as many parallel paths in the armature as the number of poles. That is why such a winding is sometimes known as 'multiple circuit' or 'parallel' winding. In general, number of parallel paths in armature = mP where m is the multiplicity (plex) of the lap winding. For example, a 6-pole duplex lap winding has $(6 \times 2) = 12$ parallel paths in its armature.
3. The e.m.f. between the +ve and -ve brushes is equal to the e.m.f. generated in any one of the parallel paths. If Z is the total number of armature conductors and P the number of poles, then the number of armature conductors (connected in series) in any parallel path is Z/P .

\therefore Generated e.m.f. $E_g = (\text{Average e.m.f./conductor}) \times \frac{Z}{P} = e_{av} \times \frac{Z}{P}$

4. The total or equivalent armature resistance can be found as follows:

Let l = length of each armature conductor; S = its cross-section
 A = No. of parallel paths in armature = P – for simplex lap winding
 R = resistance of the whole winding then $R = \frac{\rho l}{S \times Z}$

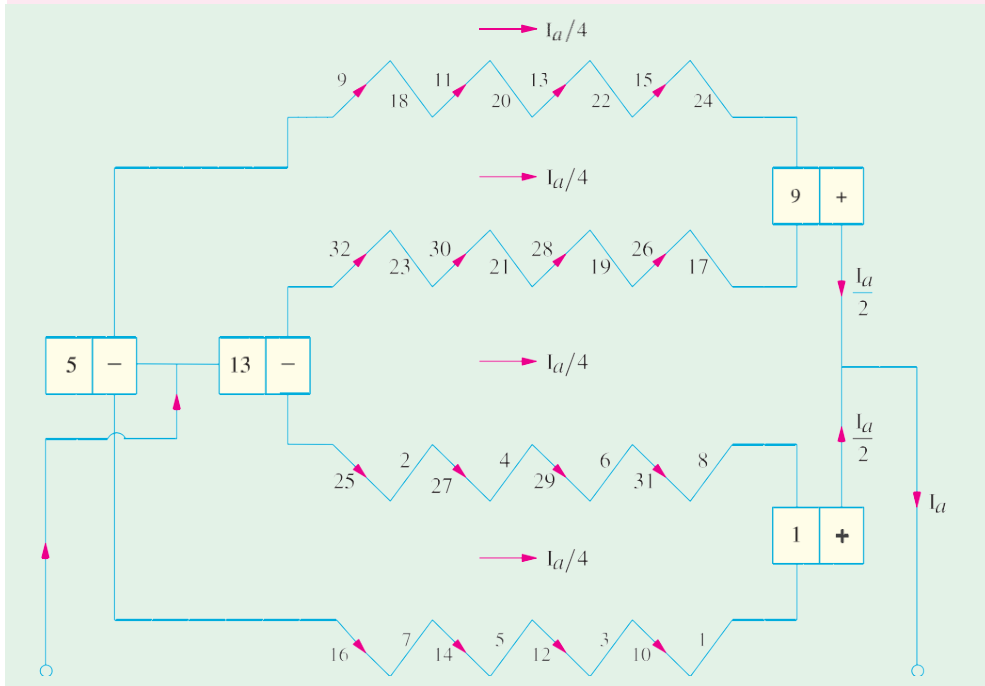

Fig. 26.34

Resistance of each path = $\frac{\rho l Z}{S \times A}$

There are P (or A) such paths in parallel, hence equivalent resistance

$= \frac{1}{A} \times \frac{\rho l Z}{SA} = \frac{\rho l Z}{SA^2}$

5. If I_a is the total armature current, then current per parallel path (or carried by each conductor) is I_a/P .

Simplex Wave Winding*

From Fig. 26.31, it is clear that in lap winding, a conductor (or coil side) under one pole is connected at the back to a conductor which occupies an almost corresponding position under the *next* pole of *opposite* polarity (as conductors 3 and 12). Conductor No. 12 is then connected to conductor No. 5 under the *original* pole but which is a little removed from the initial conductor No. 3. If, instead of returning to the same *N*-pole, the conductor No. 12 were taken *forward* to the next *N*-pole, it would make no difference so far as the direction and magnitude of the e.m.f. induced in the circuit are concerned.

* Like lap winding, a wave winding may be duplex, triplex or may have any degree of multiplicity. A simplex wave winding has two paths, a duplex wave winding four paths and a triplex one six paths etc.

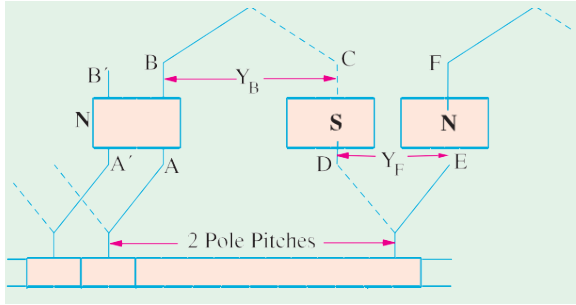

Fig. 26.35

As shown in Fig. 26.35, conductor AB is connected to CD lying under S -pole and then to EF under the next N -pole. In this way, the winding progresses, passing successively under every N -pole and S -pole till it returns to a conductor AB' lying under the original pole. Because the winding progresses in one direction round the armature in a series of 'waves', it is known as wave winding.

If, after passing once round the armature, the winding falls in a slot to the left of its starting point (as AB' in Fig. 26.35) then the winding is said to be retrogressive. If, however, it falls one slot to the right, then it is progressive.

Assuming a 2-layer winding and supposing that conductor AB lies in the upper half of the slot, then going once round the armature, the winding ends at AB' which must be at the upper half of the slot at the left or right. Counting in terms of **conductors**, it means that AB and AB' differ by two conductors (although they differ by one slot).

From the above, we can deduce the following relations. If $P =$ No. of poles, then

$$\left. \begin{aligned} Y_B &= \text{back pitch} \\ Y_F &= \text{front pitch} \end{aligned} \right\} \text{ nearly equal to pole pitch}$$

then
$$Y_A = \frac{Y_B + Y_F}{2} = \text{average pitch}; Z = \text{total No. of conductors or coil sides}$$

Then,
$$Y_A \times P = Z \pm 2 \qquad Y_A = \frac{Z \pm 2}{P}$$

Since P is always even and $Z = PY_A \pm 2$, hence Z must always be even. Put in another way, it means that $\frac{Z \pm 2}{P}$ must be an even integer.

The plus sign will give a progressive winding and the negative sign a retrogressive winding.

Points to Note :

1. Both pitches Y_B and Y_F are odd and of the same sign.
2. Back and front pitches are nearly equal to the pole pitch and may be equal or differ by 2, in which case, they are respectively one more or one less than the average pitch.
3. Resultant pitch $Y_R = Y_F + Y_B$.
4. Commutator pitch, $Y_C = Y_A$ (in lap winding $Y_C = \pm 1$).

Also,
$$Y_C = \frac{\text{No. of Commutator bars} \pm 1}{\text{No. of pair of poles}}$$

5. The average pitch which must be an integer is given by

$$Y_A = \frac{Z \pm 2}{P} = -\frac{\frac{Z}{2} + 1}{P/2} = \frac{\text{No. of Commutator bars} \pm 1}{\text{No. of pair of poles}}$$

It is clear that for Y_A to be an integer, there is a restriction on the value of Z . With $Z = 32$, this winding is impossible for a 4-pole machine (though lap winding is possible). Values of $Z = 30$ or 34 would be perfectly alright.

The simple winding table is as under :

<i>Back Connections</i>	—————>	<i>Front Connections</i>
1 to (1 + 7) = 8	—————>	8 to (8 + 7) = 15
15 to (15 + 7) = 22	—————>	22 to (22 + 7) = 29
29 to (29 + 7) = 36 = (36 - 30) = 6	—————>	6 to (6 + 7) = 13
13 to (13 + 7) = 20	—————>	20 to (20 + 7) = 27
27 to (27 + 7) = 34 = (34 - 30) = 4	—————>	4 to (4 + 7) = 11
11 to (11 + 7) = 18	—————>	18 to (18 + 7) = 25
25 to (25 + 7) = 32 = (32 - 30) = 2	—————>	2 to (2 + 7) = 9
9 to (9 + 7) = 16	—————>	16 to (16 + 7) = 23
23 to (23 + 7) = 30	—————>	30 to (30 + 7) = 37 = (37 - 30) = 7
7 to (7 + 7) = 14	—————>	14 to (14 + 7) = 21
21 to (21 + 7) = 28	—————>	28 to (28 + 7) = 35 = (35 - 30) = 5
5 to (5 + 7) = 12	—————>	12 to (12 + 7) = 19
19 to (19 + 7) = 26	—————>	26 to (26 + 7) = 33 = (33 - 30) = 3
3 to (3 + 7) = 10	—————>	10 to (10 + 7) = 17
17 to (17 + 7) = 24	—————>	24 to (24 + 7) = 31 = (31 - 30) = 1

Since we come back to the conductor No. 1 from where we started, the winding gets closed at this stage.

Brush Position

Location of brush position in wave-winding is slightly difficult. In Fig. 26.36 conductors are supposed to be moving from left to right over the poles. By applying Fleming’s Right-hand rule, the directions of the induced e.m.fs in various armature conductors can be found. The directions shown in the figure have been found in this manner. In the lower part of Fig. 26.36 is shown the equivalent ring or spiral diagram which is very helpful in understanding the formation of various parallel paths in the armature. It is seen that the winding is electrically divided into two portions. One portion consists of conductors lying between points *N* and *L* and the other of conductors lying between *N* and *M*. In the first portion, the general trend of the induced e.m.fs. is from left to right whereas in the second portion it is from right to left. Hence, in general, there are only two parallel paths through the winding, so that two brushes are required, one positive and one negative.

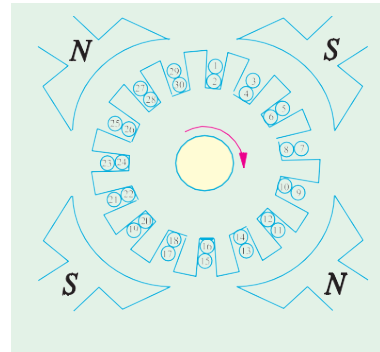

Fig. 26.37

From the equivalent ring diagram, it is seen that point *N* is the separating point of the e.m.fs. induced in the two portions of the winding. Hence, this fixes the position of the negative brush. But as it is at the back and not at the commutator end of the armature, the negative brush has two alternative positions *i.e.* either at point *P* or *Q*. These points on the equivalent diagram correspond to commutator segments No. 3 and 11.

Now, we will find the position of the positive brush. It is found that there are two meeting points of the induced e.m.fs. *i.e.* points *L* and *M* but both these points are at the back or non-commutator end of the armature. These two points are separated by one loop only, namely, the loop composed of conductors 2 and 9, hence the middle point *R* of this loop fixes the position of the positive brush, which should be placed in touch with commutator segment No. 7. We find that for one position of the +ve brush, there are two alternative positions for the -ve brush.

Taking the +ve brush at point *R* and negative brush at point *P*, the winding is seen to be divided into the following two paths.

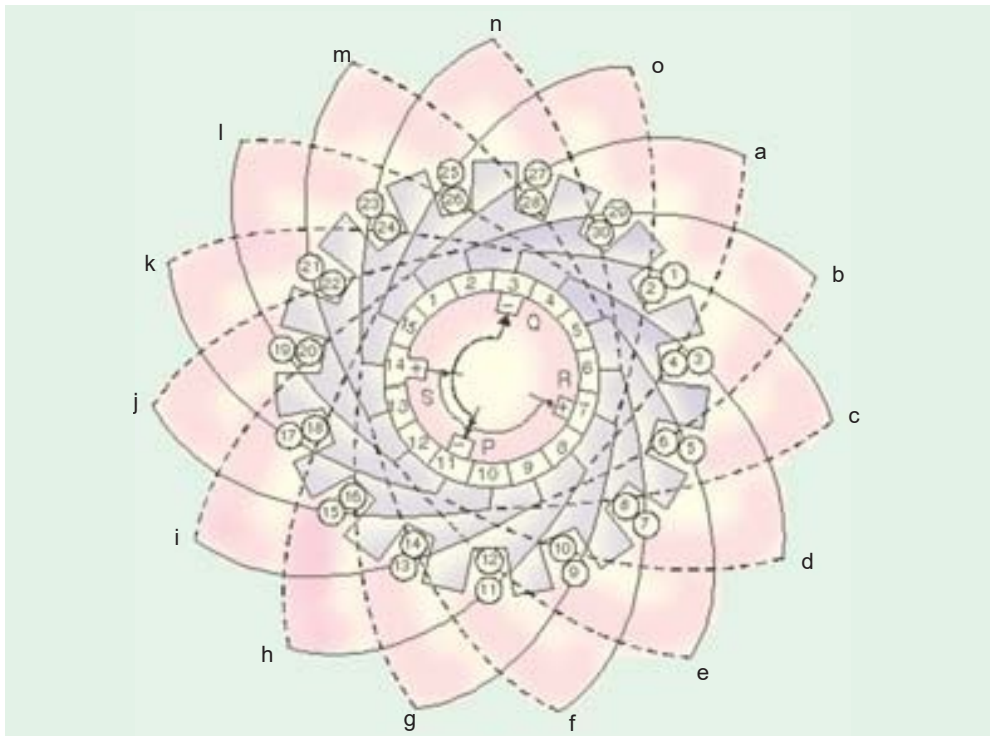

Fig. 26.38

In path 1 (Fig. 26.36) it is found that e.m.f. in conductor 9 is in opposition to the general trend of e.m.fs. in the other conductors comprising this path. Similarly, in path 2, the e.m.f. in conductor 2 is in position to the direction of e.m.fs. in the path as a whole. However, this will make no difference because these conductors lie almost in the interpolar gap and, therefore e.m.fs. in these conductors are negligible.

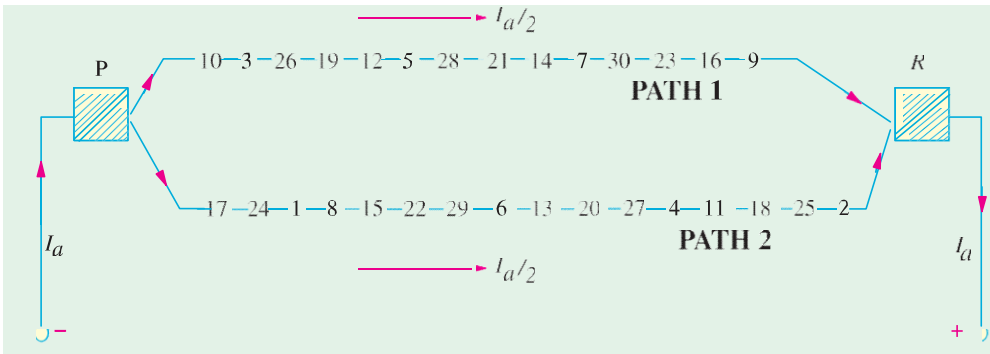

Fig. 26.39

Again, take the case of conductors 2 and 9 situated between points *L* and *M*. Since the armature conductors are in continuous motion over the pole faces, their positions as shown in the figure are only instantaneous. Keeping in this mind, it is obvious that conductor 2 is about to move from the influence of *S*-pole to that of the next *N*-pole. Hence, the e.m.f. in it is at the point of reversing. However, conductor 9 has already passed the position of reversal, hence its e.m.f. will not reverse,

rather it will increase in magnitude gradually. It means that in a very short interval, point *M* will

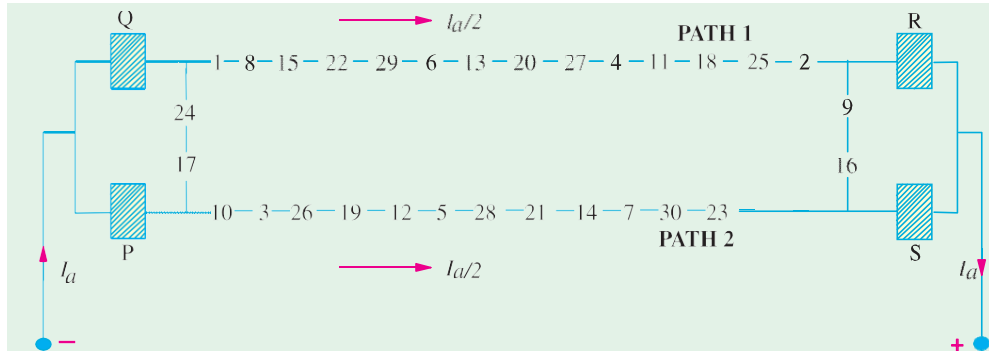

Fig. 26.40

become the meeting point of the e.m.fs. But as it lies at the back of the armature, there are two alternative positions for the +ve brush *i.e.* either point *R* which has already been considered or point *S* which corresponds to commutator segment 14. This is the second alternative position of the positive brush. Arguing in the same way, it can be shown that after another short interval of time, the alternative position of the positive brush will shift from segment 14 to segment 15. Therefore, if one positive brush is in the contact with segment 7, then the second positive brush if used, should be in touch with both segments 14 and 15.

It may be noted that if brushes are placed in both alternative positions for both positive and negative (*i.e.* if in all, 4 brushes are used, two +ve and two -ve), then the effect is merely to short-circuit the loop lying between brushes of the same polarity. This is shown in Fig. 26.40 where it will also be noted that irrespective of whether only two or four brushes are used, the number of parallel paths through the armature winding is still two.

Summarizing the above facts, we get

1. Only two brushes are necessary, though their number may be equal to the number of poles.
2. The number of parallel paths through the armature winding is two irrespective of the number of generator poles. That is why this winding is sometimes called ‘two-circuit’ or ‘series’ winding.
3. The generator e.m.f. is equal to the e.m.f. induced in any one of the two parallel paths. If e_{av} is the e.m.f. induced/conductor, then generator e.m.f. is $E_g = e_{av} \times Z/2$.
4. The equivalent armature resistance is nearly one-fourth of the total resistance of the armature winding.
5. If I_a is the total armature current, then current carried by each path or conductor is obviously $I_a/2$ whatever the number of poles.

Dummy or Idle Coils

These are used with wave-winding and are resorted to when the requirements of the winding are not met by the standard armature punchings available in armature-winding shops. These dummy coils do not influence the electrical characteristics of the winding because they are not connected to the commutator. They are exactly similar to the other coils except that their ends are cut short and taped. They are there simply to provide mechanical balance for the armature because an armature having some slots without windings would be out of balance mechanically. For example, suppose number of armature slots is 15, each containing 4 sides and the number of poles is 4. For a simplex wave-windings,



Dummy coils

$$Y_A = \frac{Z \pm 2}{P} = \frac{60 \pm 2}{4}$$

which does not come out to be an integer (Art. 26.28) as required by this winding. However, if we make one coil dummy so that we have 58 active conductors, then

$$Y_A = \frac{58 \pm 2}{4} = 14 \text{ or } 15$$

This makes the winding possible.

Uses of Lap and Wave Windings

The advantage of the wave winding is that, for a given number of poles and armature conductors, it gives more e.m.f. than the lap winding. Conversely, for the same e.m.f., lap winding would require large number of conductors which will result in higher winding cost and less efficient utilization of space in the armature slots. Hence, wave winding is suitable for small generators especially those meant for 500-600 V circuits.

Another advantage is that in wave winding, equalizing connections are not necessary whereas in a lap winding they definitely are. It is so because each of the two paths contains conductors lying under all the poles whereas in lap-wound armatures, each of the P parallel paths contains conductors which lie under one pair of poles. Any inequality of pole fluxes affects two paths equally, hence their induced e.m.fs. are equal. In lap-wound armatures, unequal voltages are produced which set up a circulating current that produces sparking at brushes.

However, when large currents are required, it is necessary to use lap winding, because it gives more parallel paths.

Hence, lap winding is suitable for comparatively low-voltage but high-current generators whereas wave-winding is used for high-voltage, low-current machines.

Tutorial Problem No. 26.1

1. Write down the winding table for a 2-layer simplex lap-winding for a 4-pole d.c. generator having (a) 20 slots and (b) 13 slots. What are the back and front pitches as measured in terms of armature conductors ?

[Hint : (a) No. of conductors = 40 ; $Y_B = 11$ and $Y_F = -9$] (Elect. Engineering, Madras Univ. 1978)

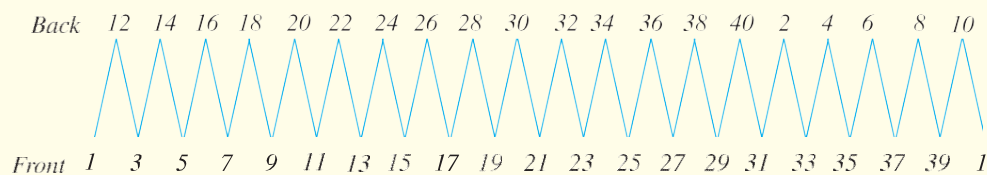

- (b) No. of conductors = 26 ; $Y_B = 7$; $Y_F = -5$

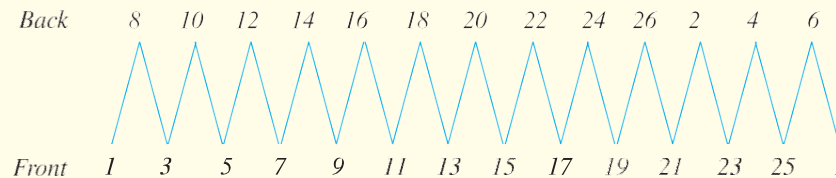

2. With a simplex 2-layer wave winding having 26 conductors and 4-poles, write down the winding table. What will be the front and back pitches of the winding ?

[Hint : $Y_F = 7$ and $Y_B = 5$]

(Electric Machinery-I, Madras Univ. Nov. 1979)

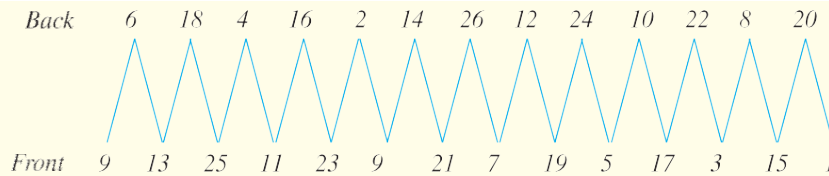

3. Is it possible to get simplex wave winding for a 4-pole d.c. machine with 28 conductors? Explain the reason for your answer. **[No, it would contain only 4 conductors]**

4. State for what type of winding each of the following armatures could be used and whether the winding must be four or six-pole if no dummy coils are to be used (a) 33 slots, 165 commutator segments (b) 64 slots, 256 commutator segments (c) 65 slots, 260 commutator segments.

- [(a) 4-pole lap with commutator pitch 82 or 83 or 6-pole lap.**
- (b) 4-pole lap or 6-pole wave with commutator pitch 85.**
- (c) 6-pole wave with commutator pitch 87.]**

Types of Generators

Generators are usually classified according to the way in which their fields are excited. Generators may be divided into (a) separately-excited generators and (b) self-excited generators.

(a) **Separately-excited** generators are those whose field magnets are energised from an independent external source of d.c. current. It is shown diagrammatically in Fig. 26.41.

(b) **Self-excited generators** are those whose field magnets are energised by the current produced by the generators themselves. Due to residual magnetism, there is always present some flux in the poles. When the armature is rotated, some e.m.f. and hence some induced current is produced which is partly or fully passed through the field coils thereby strengthening the residual pole flux.

There are three types of self-excited generators named according to the manner in which their field coils (or windings) are connected to the armature.

(i) Shunt wound

The field windings are connected across or in parallel with the armature conductors and have the full voltage of the generator applied across them (Fig. 26.42).

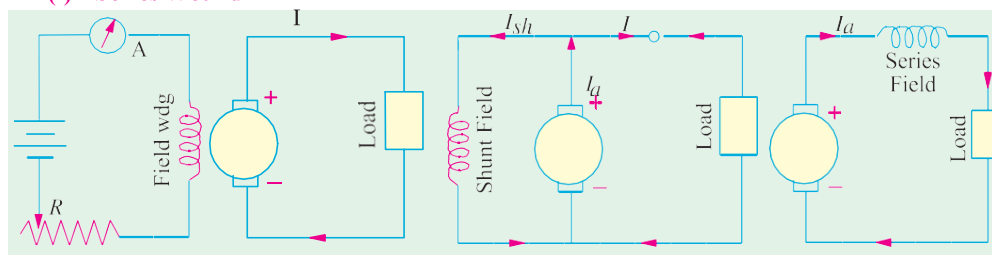

Fig. 26.41

Fig. 26.42

Fig. 26.43

In this case, the field windings are joined in series with the armature conductors (Fig. 26.43). As they carry full load current, they consist of relatively few turns of thick wire or strips. Such generators are rarely used except for special purposes *i.e.* as boosters etc.

(iii) Compound Wound

It is a combination of a few series and a few shunt windings and can be either short-shunt or long-shunt as shown in Fig. 26.44 (a) and

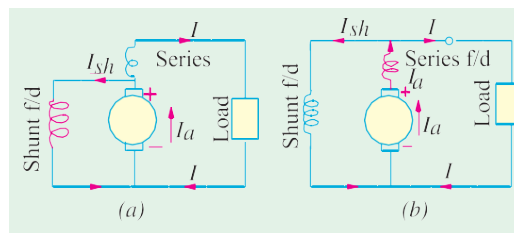

Fig. 26.44

(b) respectively. In a compound generator, the shunt field is stronger than the series field. When series field *aids* the shunt field, generator is said to be *cumulatively-compounded*. On the other hand if series field *opposes* the shunt field, the generator is said to be *differentially compounded*. Various types of d.c. generators have been shown separately in Fig. 26.45.

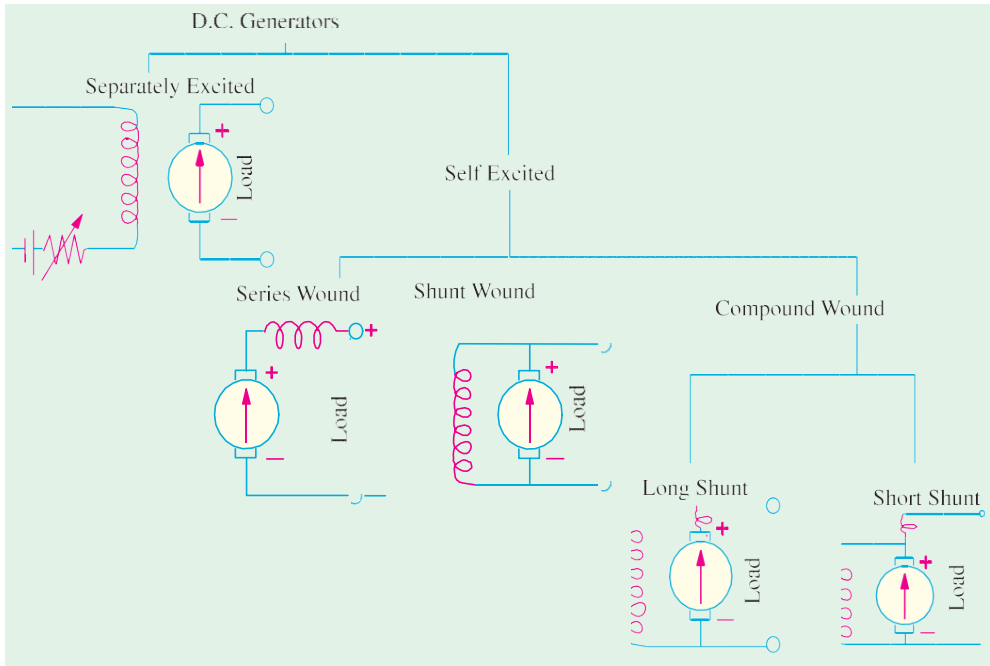

Fig. 26.45

Brush Contact Drop

It is the voltage drop over the brush contact resistance when current passes from commutator segments to brushes and finally to the external load. Its value depends on the amount of current and the value of contact resistance. This drop is usually small and includes brushes of both polarities. However, in practice, the brush contact drop is assumed to have following constant values for all loads.

- 0.5 V for metal-graphite brushes.
- 2.0 V for carbon brushes.

Example 26.3. A shunt generator delivers 450 A at 230 V and the resistance of the shunt field and armature are 50 Ω and 0.03 Ω respectively. Calculate the generated e.m.f.

Solution. Generator circuit is shown in Fig. 26.46.

Current through shunt field winding is

$$I_{sh} = 230/50 = 4.6 \text{ A}$$

Load current $I = 450 \text{ A}$

$$\therefore \text{Armature current } I_a = I + I_{sh} = 450 + 4.6 = 454.6 \text{ A}$$

Armature voltage drop

$$I_a R_a = 454.6 \times 0.03 = 13.6 \text{ V}$$

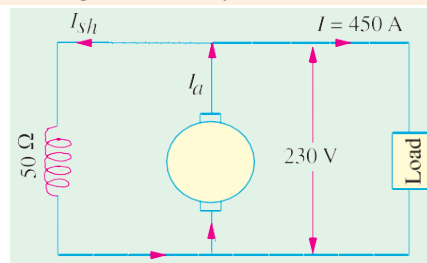

Fig. 26.46

Now $E_g = \text{terminal voltage} + \text{armature drop}$
 $= V + I_a R_a$

∴ e.m.f. generated in the armature

$$E_g = 230 + 13.6 = 243.6 \text{ V}$$

Example 26.4. A long-shunt compound generator delivers a load current of 50 A at 500 V and has armature, series field and shunt field resistances of 0.05 Ω, 0.03 Ω and 250 Ω respectively. Calculate the generated voltage and the armature current. Allow 1 V per brush for contact drop.

(Elect. Science 1, Allahabad Univ. 1992)

Solution. Generator circuit is shown in Fig. 26.47.

$$I_{sh} = 500/250 = 2 \text{ A}$$

Current through armature and series winding is
 $= 50 + 2 = 52 \text{ A}$

Voltage drop on series field winding
 $= 52 \times 0.03 = 1.56 \text{ V}$

Armature voltage drop
 $I_a R_a = 52 \times 0.05 = 2.6 \text{ V}$

Drop at brushes $= 2 \times 1 = 2 \text{ V}$

Now, $E_g = V + I_a R_a + \text{series drop} + \text{brush drop}$
 $= 500 + 2.6 + 1.56 + 2 = 506.16 \text{ V}$

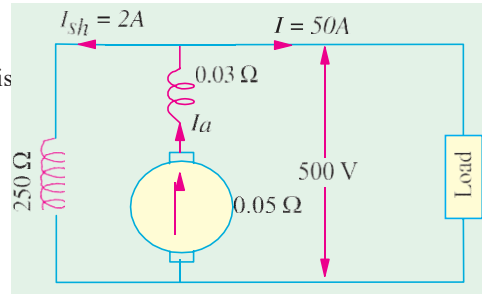

Fig. 26.47

Example 26.5. A short-shunt compound generator delivers a load current of 30 A at 220 V, and has armature, series-field and shunt-field resistances of Ω, 0.30 Ω and 200 Ω respectively. Calculate the induced e.m.f. and the armature current. Allow 1.0 V per brush for contact drop.

(AMIE Sec. B. Elect. Machines 1991)

Solution. Generator circuit diagram is shown in Fig. 26.48.

Voltage drop in series winding $= 30 \times 0.3 = 9 \text{ V}$

Voltage across shunt winding $= 220 + 9 = 229 \text{ V}$

$$I_{sh} = 229/200 = 1.145 \text{ A}$$

$$I_a = 30 + 1.145 = 31.145 \text{ A}$$

$$I_a R_a = 31.145 \times 0.05 = 1.56 \text{ V}$$

Brush drop $= 2 \times 1 = 2 \text{ V}$

$$E_g = V + \text{series drop} + \text{brush drop} + I_a R_a$$

$$= 220 + 9 + 2 + 1.56 = 232.56 \text{ V}$$

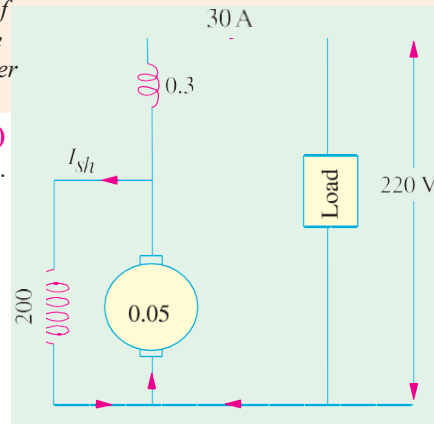

Fig. 26.48

Example 26.6. In a long-shunt compound generator, the terminal voltage is 230 V when generator delivers 150 A. Determine (i) induced e.m.f. (ii) total power generated and (iii) distribution of this power. Given that shunt field, series field, divertor and armature resistance are 92 Ω, 0.015 Ω, 0.03 Ω and 0.032 Ω respectively.

(Elect. Technology-II, Gwalior Univ. 1987)

Solution.

$$I_{sh} = 230/92 = 2.5 \text{ A}$$

$$I_a = 150 + 2.5 = 152.5 \text{ A}$$

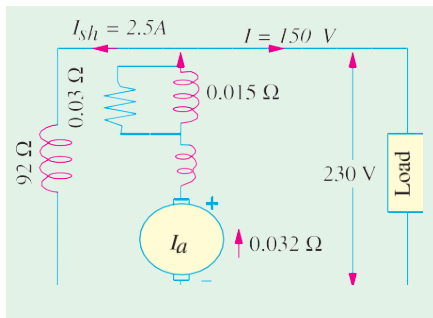

Fig. 26.49

Power lost in series field and diverter
 Power dissipated in shunt winding
 Power delivered to load

Since series field resistance and diverter resistances are in parallel (Fig. 26.49) their combined resistance is
 $= 0.03 \times 0.015 / 0.045 = 0.01 \Omega$

Total armature circuit resistance is
 $= 0.032 + 0.01 = 0.042 \Omega$

Voltage drop = $152.5 \times 0.042 = 6.4 \text{ V}$

(i) Voltage generated by armature

$$E_g = 230 + 6.4 = 236.4 \text{ V}$$

(ii) Total power generated in armature

$$E_g I_a = 236.4 \times 152.5 = 36,051 \text{ W}$$

(iii) Power lost in armature

$$I_a^2 R_{aa} = 152.5^2 \times 0.032 = 744 \text{ W}$$

$$= 152.5^2 \times 0.01 = 232 \text{ W}$$

$$= V I_{sh} = 230 \times 0.01 = 575 \text{ W}$$

$$= 230 \times 150 = 34500 \text{ W}$$

$$\text{Total} = \underline{36,051 \text{ W}}$$

Example 26.7. The following information is given for a 300-kW, 600-V, long-shunt compound generator : Shunt field resistance = 75 Ω, armature resistance including brush resistance = 0.03 Ω, commutating field winding resistance = 0.011 Ω, series field resistance = 0.012 Ω, diverter resistance = 0.036 Ω. When the machine is delivering full load, calculate the voltage and power generated by the armature.

(Elect. Engg-II, Pune Univ. Nov. 1989)

Solution. Power output = 300,000 W

$$\text{Output current} = 300,000 / 600 = 500 \text{ A}$$

$$I_{sh} = 600 / 75 = 8 \text{ A,}$$

$$I_a = 500 + 8 = 508 \text{ A}$$

Since the series field resistance and diverter resistance are in parallel (Fig. 26.50) their combined resistance is

$$= \frac{0.012 \times 0.036}{0.048} = 0.009 \Omega$$

Total armature circuit resistance

$$= 0.03 - 0.011 + 0.009 = 0.05 \Omega$$

$$\text{Voltage drop} = 508 \times 0.05 = 25.4 \text{ V}$$

Voltage generated by armature

$$= 600 + 25.4 = 625.4 \text{ V}$$

$$\text{Power generated} = 625.4 \times 508 = 317,700$$

$$W = \underline{317.7 \text{ kW}}$$

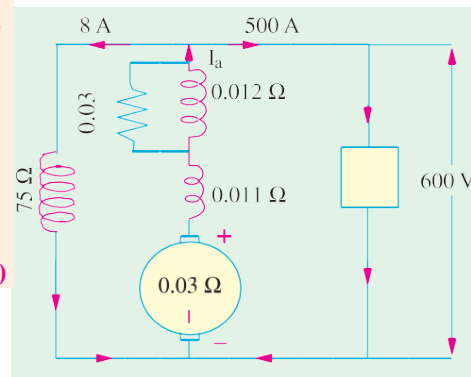

Fig. 26.50

Generated E.M.F. or E.M.F. Equation of a Generator

Let Φ = flux/pole in weber

Z = total number of armature conductors

= No. of slots \times No. of conductors/slot
 P = No. of generator poles
 A = No. of parallel paths in armature
 N = armature rotation in revolutions per minute (r.p.m.)
 E = e.m.f. induced in any parallel path in armature
 Generated e.m.f. E_g = e.m.f. generated in any one of the parallel paths *i.e.* E .

Average e.m.f. generated/conductor = $\frac{d\Phi}{dt}$ volt ($\because n = 1$)
 Now, flux cut/conductor in one revolution $d\Phi = \Phi P$ Wb
 No. of revolutions/second = $N/60$ \therefore Time for one revolution, $dt = 60/N$ second
 Hence, according to Faraday's Laws of Electromagnetic Induction,
 E.M.F. generated/conductor = $\frac{d\Phi}{dt} = \frac{\Phi P N}{60}$ volt

For a simplex wave-wound generator

No. of parallel paths = 2
 No. of conductors (in series) in one path = $Z/2$
 \therefore E.M.F. generated/path = $\frac{\Phi P N}{60} \times \frac{Z}{2} = \frac{\Phi Z P N}{120}$ volt

For a simplex lap-wound generator

No. of parallel paths = P
 No. of conductors (in series) in one path = Z/P
 \therefore E.M.F. generated/path = $\frac{\Phi P N}{60} \times \frac{Z}{P} = \frac{\Phi Z N}{60}$ volt
 In general generated e.m.f. $E_g = \frac{\Phi Z N}{60} \times \left(\frac{P}{A}\right)$ volt
 where $A = 2$ -for simplex wave-winding
 $= P$ -for simplex lap-winding
 Also, $E_g = \frac{1}{2\pi} \cdot \left(\frac{2\pi N}{60}\right) \Phi Z \left(\frac{P}{A}\right) = \frac{\omega \Phi Z}{2\pi} \left(\frac{P}{A}\right)$ volt – ω in rad/s

For a given d.c. machine, Z, P and A are constant. Hence, putting $K_a = ZP/A$, we get

$$E_g = K_a \Phi N \text{ volts—where } N \text{ is in r.p.s.}$$

Example 26.8. A four-pole generator, having wave-wound armature winding has 51 slots, each slot containing 20 conductors. What will be the voltage generated in the machine when driven at 1500 rpm assuming the flux per pole to be 7.0 mWb? (Elect. Machines-I, Allahabad Univ. 1993)

Solution. $E_g = \frac{\Phi Z N}{60} \left(\frac{P}{A}\right)$ volts

Here, $\Phi = 7 \times 10^{-3}$ Wb, $Z = 51 \times 20 = 1020$, $A = P = 4$, $N = 1500$ r.p.m.

$$\therefore E_g = \frac{7 \times 10^{-3} \times 1020 \times 1500}{60} \left(\frac{4}{2}\right) = 178.5 \text{ V}$$

Example 26.9. An 8-pole d.c. generator has 500 armature conductors, and a useful flux of 0.05 Wb per pole. What will be the e.m.f. generated if it is lap-connected and runs at 1200 rpm? What must be the speed at which it is to be driven produce the same e.m.f. if it is wave-wound?

(U.P. Technical Univ. 2001)

Solution. With lap-winding, $P = a = 8$

$$E = \phi (N/60) (P/a)$$

$$= 0.05 \times 500 \times 20 \times 1,$$

$$= 500 \text{ volts}$$

for lap-winding

If it is wave-wound, $P = 8, a = 2, P/a = 4$

and $E = 0.05 \times 500 \times (N/60) \times 4$

For $E = 500 \text{ volts}, N = 300 \text{ rpm}$

Hence, with wave-winding, it must be driven at 300 rpm to generate 500 volts.

Additional Explanation. Assume 1 amp as the current per conductor.

(a) Lap-wound, 1200 rpm : 500 V per coil-group, 8 groups in parallel

Net output current = 8 amp as in Fig. 26.51 (a).

Power output = 4 kW

(b) Wave-wound, 300 rpm : 2 groups in parallel, one group has four coils in series, as shown in Fig. 26.51 (b).

Total power-output is now

$$500 \times 2 = 1000 \text{ W.}$$

It is reduced to one fourth, being proportional to the speed.

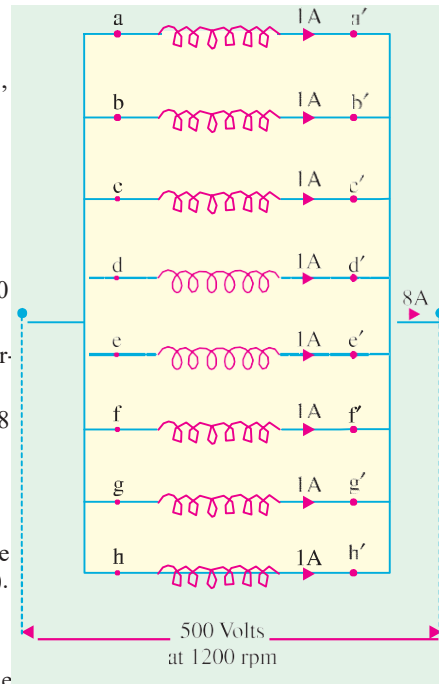

Fig. 26.51(a)

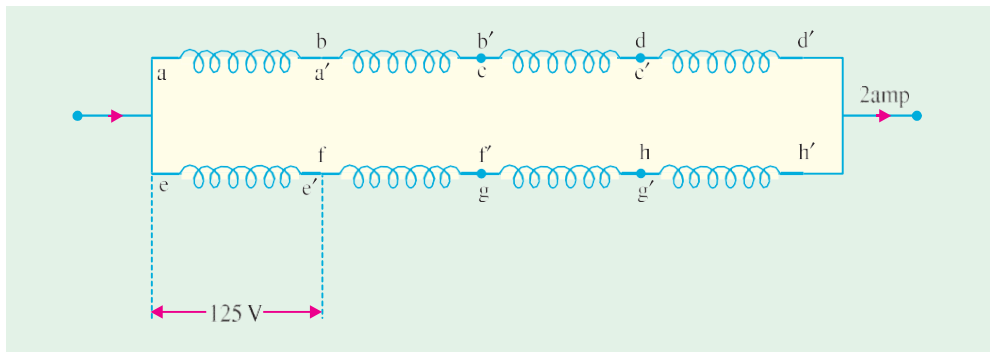

Fig. 26.51(b)

Example 26.10. A d.c. shunt generator has an induced voltage on open-circuit of 127 volts. When the machine is on load, the terminal voltage is 120 volts. Find the load current if the field-circuit resistance is 15 ohms and the armature-resistance is 0.02 ohm. Ignore armature reaction.

(Madras University April 1997, Bharathiar University Nov. 1997)

Solution.

Note : Even though the question does not specify some conditions, the solution given here is based on correct approach to deal with the case.

Generator on no load :

As shown in Fig. 26.52 (a), the machine is run at N_1 rpm.

$$E_g = 127 + 8.47 \times 0.02 = 127.17 \text{ volts}$$

As in Fig. 26.52 (b), $i_f = 8$ amp

E_g can be 127.17 volts, if the speed is increased to N_2 rpm, such that

$$\frac{8.47 N_1}{1} = \frac{8 N_2}{2}, \text{ or } N_2 = \frac{8.47}{8} N_1 = 1.05875 N_1$$

Thus the effect due to 5.875% decrease in flux is compensated by 5.875% increase in speed.

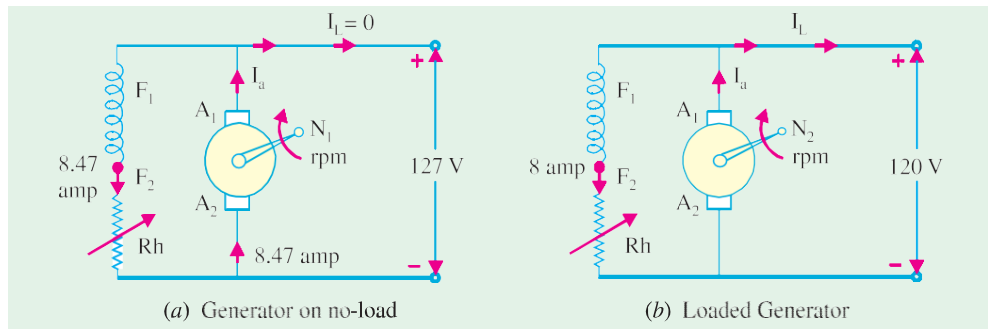

Fig. 26.52

If E_g is assumed to remain unaltered at 127.17 V,

$$I_a = \frac{127.17 - 120}{0.02} = 358.5 \text{ amp}$$

Hence, $I_L = 358.5 - 8 = 350.5$ amp.

Example 26.11(a). An 8-pole d.c. shunt generator with 778 wave-connected armature conductors and running at 500 r.p.m. supplies a load of 12.5Ω resistance at terminal voltage of 50 V. The armature resistance is 0.24Ω and the field resistance is 250Ω . Find the armature current, the induced e.m.f. and the flux per pole.

(Electrical Engg-I, Bombay Univ. 1988)

Solution. The circuit is shown in Fig. 26.53

$$\text{Load current} = V/R = 250/12.5 = 20 \text{ A}$$

$$\text{Shunt current} = 250/250 = 1 \text{ A}$$

$$\text{Armature current} = 20 + 1 = 21 \text{ A}$$

$$\text{Induced e.m.f.} = 250 + (21 \times 0.24) = 255.04 \text{ V}$$

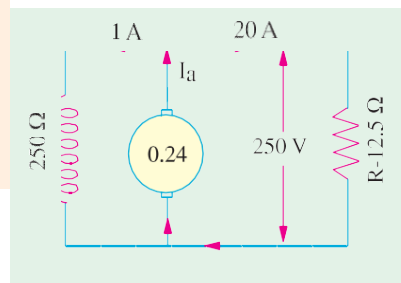

Fig. 26.53

Now,

$$E_g = \frac{\Phi Z N}{60} \times \left(\frac{P}{A}\right)$$

$$\therefore 255.04 = \frac{\Phi \times 778 \times 500}{60} \left(\frac{8}{2}\right)$$

$$\therefore \Phi = 9.83 \text{ mWb}$$

Example 26.11(b). A 4-pole lap-connected armature of a d.c. shunt generator is required to supply the loads connected in parallel :

- (1) 5 kW Geyser at 250 V, and
- (2) 2.5 kW Lighting load also at 250 V.

The Generator has an armature resistance of 0.2 ohm and a field resistance of 250 ohms. The armature has 120 conductors in the slots and runs at 1000 rpm. Allowing 1 V per brush for contact drops and neglecting friction, find

- (1) Flux per pole, (2) Armature-current per parallel path. (Nagpur University Nov. 1998)

Solution. Geysers current = $5000/250 = 20$ A
 Current for Lighting = $2500/250 = 10$ A
 Total current = 30 A
 Field Current for Generator = 1 A
 Hence, Armature Current = 31 A
 Armature resistance drop = $31 \times 0.2 = 6.2$ volts
 Generated e.m.f. = $250 + 6.2 + 2 = 258.2$ V,

since $E = V_t + I_a r_a + \text{Total brush contact drop}$
 For a 4-pole lap-connected armature,
 Number of parallel paths = number of poles = 4

(1) The flux per pole is obtained from the emf equation

$$\begin{aligned} 258.2 &= [\phi Z N/60] \times (p/a) \\ &= [\phi \times 120 \times 1000/60] \times (4/4) \\ &= 2000 \phi \\ \phi &= 129.1 \text{ mWb} \end{aligned}$$

(2) Armature current per parallel path = $31/4 = 7.75$ A.

Example 26.12. A separately excited generator, when running at 1000 r.p.m. supplied 200 A at 125 V. What will be the load current when the speed drops to 800 r.p.m. if I_f is unchanged? Given that the armature resistance = 0.04 ohm and brush drop = 2 V.

(Elect. Machines Nagpur Univ. 1993)

Solution. The load resistance $R = 125/200 = 0.625 \Omega$, in Fig. 26.54.

$$E_{g1} = 125 + 200 \times 0.04 + 2 = 135 \text{ V}; N_1 = 1000 \text{ r.p.m.}$$

$$\text{At } 800 \text{ r.p.m. } E_{g2} = 135 \times 800/1000 = 108 \text{ V}$$

If I is the new load current, then terminal voltage V is given by

$$V = 108 - 0.04 I - 2 = 106 - 0.04 I$$

$$\therefore I = V/R = (106 - 0.04 I)/0.635; I = 159.4 \text{ A}$$

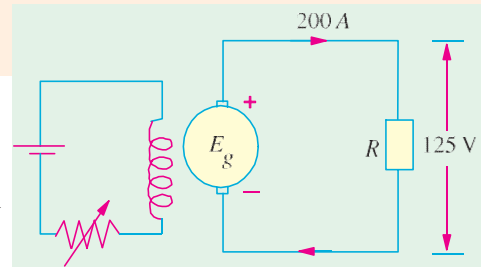

Fig. 26.54

Example 26.13. A 4-pole, 900 r.p.m. d.c. machine has a terminal voltage of 220 V and an induced voltage of 240 V at rated speed. The armature circuit resistance is 0.2Ω . Is the machine operating as a generator or a motor? Compute the armature current and the number of armature coils if the air-gap flux/pole is 10 mWb and the armature turns per coil are 8. The armature is wave-wound.
 (Elect. Machines AMIE Sec. B 1990)

Solution. Since the induced voltage E is more than the terminal voltage v , the machine is working as a generator.

$$E - V = I_a R_a \text{ or } 240 - 220 = I_a \times 0.2; I_a = 100 \text{ A}$$

Now,

$$E_b = ZN(P/A) \text{ or } 240 = 10 \times 10^{-3} \times z \times (900/600) (4/2); Z = 8000$$

Since there are 8 turns in a coil, it means there are 16 active conductors/coil. Hence, the number of coils = $8000/16 = 500$.

Example 26.14. In a 120 V compound generator, the resistances of the armature, shunt and series windings are 0.06Ω , 25Ω and 0.04Ω respectively. The load current is 100 A at 120 V. Find the induced e.m.f. and the armature current when the machine is connected as (i) long-shunt and as (ii) short-shunt. How will the ampere-turns of the series field be changed in (i) if a diverter of 0.1 ohm be connected in parallel with the series winding? Neglect brush contact drop and ignore armature reaction.
 (Elect. Machines AMIE Sec. B, 1992)

Solution. (i) Long Shunt [Fig. 26.55 (a)]

$$I_{sh} = 120/25 = 4.8 \text{ A} ; I = 100 \text{ A} ; I_a = 104.8 \text{ A}$$

$$\text{Voltage drop in series winding} = 104.8 \times 0.04 = 4.19 \text{ V}$$

$$\text{Armature voltage drop} = 104.8 \times 0.06 = 6.29 \text{ V}$$

$$\therefore E_g = 120 + 3.19 + 6.29 = 130.5 \text{ V}$$

(ii) Short Shunt [Fig. 26.55 (c)]

$$\text{Voltage drop in series winding} = 100 \times 0.04 = 4 \text{ V}$$

$$\text{Voltage across shunt winding} = 120 + 4 = 124 \text{ V}$$

$$\therefore I_{sh} = 124/25 = 5 \text{ A} ; \therefore I_a = 100 + 5 = 105 \text{ A}$$

$$\text{Armature voltage drop} = 105 \times 0.06 = 6.3 \text{ V}$$

$$E_g = 120 + 5 + 4 = 129 \text{ V}$$

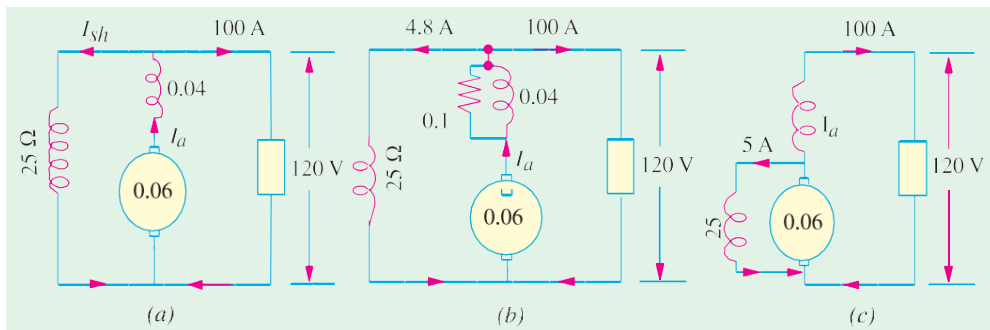

Fig. 26.55

When a diverter of 0.1Ω is connected in parallel with the series winding, the diagram becomes as shown in Fig. 26.55 (b). As per current-divider rule, the current through the series winding is $= 104.8 \times 0.1/(0.1 + 0.04) = 74.86 \text{ A}$. It means that the series field current has decreased from an original value of 104.8 A to 74.86 A . Since No. of turns in the series winding remains the same, the change in series field ampere-turns would be the same as the change in the field current. Hence, the percentage decrease in the series field ampere-turns $= (74.86 - 104.8) \times 100/104.8 = -28.6\%$.

Example 26.15. A 4-pole, long-shunt lap-wound generator supplies 25 kW at a terminal voltage of 500 V. The armature resistance is 0.03 ohm, series field resistance is 0.04 ohm and shunt field resistance is 200 ohm. The brush drop may be taken as 1.0 V. Determine the e.m.f. generated.

Calculate also the No. of conductors if the speed is 1200 r.p.m. and flux per pole is 0.02 weber. Neglect armature reaction.

(Elec. Engineering-I, St. Patel Univ. 1986)

Solution. $I = 25,000/500 = 50 \text{ A}$, $I_{sh} = 500/200 = 2.5 \text{ A}$ (Fig. 26.56)

$$I_a = I + I_{sh} = 50 + 2.5 = 52.5 \text{ A}$$

$$\text{Series field drop} = 52.5 \times 0.04 = 2.1 \text{ V}$$

$$\text{Armature drop} = 52.5 \times 0.03 = 1.575 \text{ V}$$

$$\text{Brush drop} = 2 \times 1 = 2 \text{ V}$$

$$\text{Generated e.m.f., } E_g = 500 + 2.1 + 1.575 + 2 = \mathbf{505.67 \text{ V}}$$

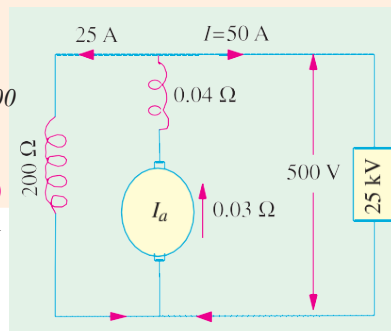

Fig. 26.56

Now,
$$E_g = \frac{\Phi Z N}{60} \left(\frac{P}{A} \right)$$

or
$$505.67 = \frac{0.02 \times Z \times 1200}{60} \left(\frac{4}{4} \right), Z = 1264$$

Example 26.16. A 4-pole d.c. generator runs at 750 r.p.m. and generates an e.m.f. of 240 V. The armature is wave-wound and has 792 conductors. If the total flux from each pole is 0.0145 Wb, what is the leakage coefficient?

Solution. Formula used :

$$E = \frac{\Phi Z N}{60} \left(\frac{P}{A} \right) \text{ volt} \quad \therefore 240 = \frac{\Phi \times 750 \times 792}{60} \times \frac{4}{2}$$

\therefore Working flux/pole, $\Phi = 0.0121$ Wb ; Total flux/pole = 0.0145 Wb

\therefore Leakage coefficient $\lambda = \frac{\text{total flux/pole}}{\text{working flux/pole}} = \frac{0.0145}{0.0121} = 1.2$

Example 26.17. A 4-pole, lap-wound, d.c. shunt generator has a useful flux per pole of 0.07 Wb. The armature winding consists of 220 turns each of 0.004 Ω resistance. Calculate the terminal voltage when running at 900 r.p.m. if the armature current is 50 A.

Solution. Since each turn has two sides,

$$\therefore E_g = \frac{\Phi Z N}{60} \left(\frac{P}{A} \right) = \frac{0.07 \times 440 \times 900}{60} \times \left(\frac{4}{4} \right) = 462 \text{ volt}$$

Total resistance of 220 turns (or 440 conductors) = $220 \times 0.004 = 0.88 \Omega$

Since there are 4 parallel paths in armature,

\therefore Resistance of each path = $0.88/4 = 0.22 \Omega$

Now, there are four such resistances in parallel each of value 0.22Ω

\therefore Armature resistance, $R_a = 0.22/4 = 0.055 \Omega$

Armature drop = $I_a R_a = 50 \times 0.055 = 2.75 \Omega$

Now, terminal voltage $V = E_g - I_a R_a = 462 - 2.75 = 459.25 \text{ volt.}$

Example 26.18. A 4-pole, lap-wound, long-shunt, d.c. compound generator has useful flux per pole of 0.07 Wb. The armature winding consists of 220 turns and the resistance per turn is 0.004 ohms. Calculate the terminal voltage if the resistance of shunt and series field are 100 ohms and 0.02 ohms respectively ; when the generator is running at 900 r.p.m. with armature current of 50 A. Also calculate the power output in kW for the generator.

(Basic Elect. Machine Nagpur Univ. 1993)

Solution.
$$E_b = \frac{0.07 \times (220 \times 2) \times 900}{60} \times \left(\frac{4}{4} \right) = 462 \text{ V}$$

As found in Ex. 26.17, $R_a = 0.055 \Omega$

Arm. circuit resistance = $R_a + R_{se} = 0.055 + 0.02 = 0.075 \Omega$

Arm. circuit drop = $50 \times 0.075 = 3.75 \text{ V}$

$V = 462 - 3.75 = 458.25 \text{ V}$, in Fig. 26.57.

$I_{sh} = 458.25/100 = 4.58 \text{ A}$; $I = 50 - 4.58 = 45.42 \text{ A}$

Output = $VI = 458.25 \times 45.42 = 20,814 \text{ W} = 20.814 \text{ kW}$

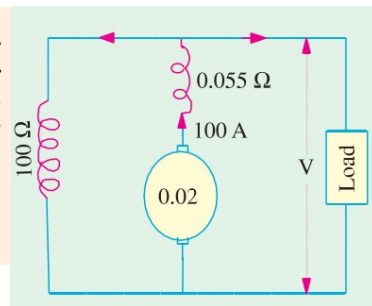

Fig. 26.57

Example 26.19. A separately excited d.c. generator, when running at 1200 r.p.m. supplies 200 A at 125 V to a circuit of constant resistance. What will be the current when the speed is dropped to 1000 r.p.m. and the field current is reduced to 80%? Armature resistance, 0.04 Ω and total drop at brushes, 2 V. Ignore saturation and armature reaction.

(Elect. Machines AMIE Sec. B, 1991)

Solution. We will find the generated e.m.f. when the load current is 200 A.

$$E_{g1} = V + \text{brush drop} + I_a R_a = 125 + 200 \times 0.04 = 135 \text{ V, in Fig. 26.58.}$$

$$\text{Now, } E_{g1} \propto \Phi_1 N_1 \text{ and } E_{g2} \propto \Phi_2 N_2$$

$$\therefore \frac{E_{g2}}{E_{g1}} = \frac{\Phi_2 N_2}{\Phi_1 N_1}$$

$$\text{or } \frac{E_{g2}}{135} = 0.8 \times \frac{1000}{1200} = 90 \text{ V}$$

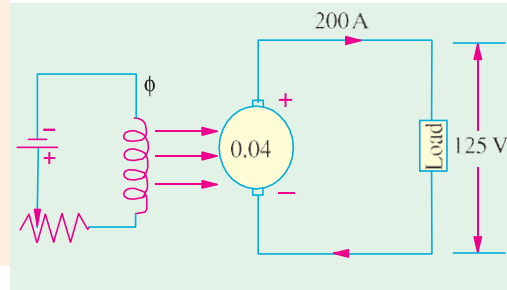

Fig. 26.58

Example 26.20(a). A 4-pole, d.c. shunt generator with a shunt field resistance of 100 Ω and an armature resistance of 1 Ω has 378 wave-connected conductors in its armature. The flux per pole is 0.02 Wb. If a load resistance of 10 Ω is connected across the armature terminals and the generator is driven at 1000 r.p.m., calculate the power absorbed by the load.

(Elect. Technology, Hyderabad Univ. 1991)

Solution. Induced e.m.f. in the generator is

$$E_s = \frac{\Phi Z N \left(\frac{P}{A}\right)}{60} \text{ volt}$$

$$= \frac{0.02 \times 378 \times 1000 \times 4}{60} = 252 \text{ volt}$$

Now, let V be the terminal voltage i.e. the voltage available across the load as well as the shunt resistance (Fig. 26.59).

$$\text{Load current} = V/10 \text{ A and Shunt current} = V/100 \text{ A}$$

$$\text{Armature current} = \frac{V}{10} + \frac{V}{100} = \frac{11V}{100}$$

$$\text{Now, } V = E_g - \text{armature drop}$$

$$\therefore V = 252 - 1 \times \frac{11V}{100} \quad \therefore V = 227 \text{ volt}$$

$$\text{Load current} = 227/10 = 22.7 \text{ A, Power absorbed by the load is} = 227 \times 22.7 = 5,153 \text{ W}$$

Example 26.20(b). A four-pole, lap-wound shunt generator has 300 armature-conductors and a flux/pole of 0.1 Wb. It runs at 1000 r.p.m. The armature and field-resistances are 0.2 ohm and 125 ohms respectively. Calculate the terminal voltage when it is loaded to take a load current of 90 A. Ignore armature reaction.

(Nagpur University, April 1999)

Solution. First, the e.m.f. should be calculated

$$E = 0.1 \times 300 \times (1000/60) \times (4/4) = 500 \text{ volts}$$

$$\text{The field current } 500/125 = 4 \text{ amp}$$

$$\text{For the load current of 90 amp, armature current} = 94 \text{ amp}$$

$$I_a r_a = 94 \times 0.20 = 18.8 \text{ volts}$$

$$\text{Terminal voltage, } V = 500 - 18.8 = 481.2 \text{ volts}$$

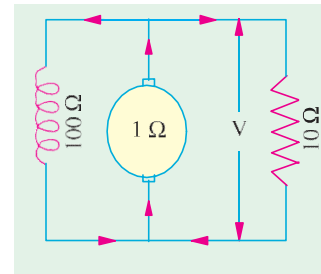

Fig. 26.59

Note : Due to the reduction in terminal voltage (as an effect of loading), the shunt field current tends to decrease, which will further reduce V . To compensate for this, either increase the speed slightly or decrease the shunt-field-circuit resistance slightly.

Example 26.21(a). A 6-pole dc generator runs at 1200 r.p.m. on no-load and has a generated e.m.f. of 250 V. Its armature diameter is 350 mm and the radial air-gap between the field poles and the armature is 3 mm. The axial length of the field poles is 260 mm and the field pole effective coverage is 80% including fringing. If the armature has 96 coils having 3 turns per coil and is wound duplex lap, calculate (a) flux per pole (b) effective pole arc length and (c) average air-gap flux density.

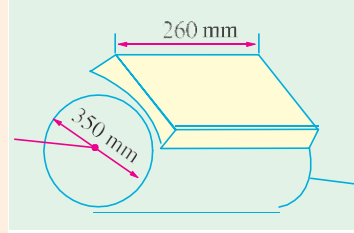

Fig. 26.60

Solution. (a) $Z = (96 \times 3) \times 2 = 576$, $P = 6$, $A = P \times \text{plex} = 6 \times 2 = 12$, $N = 1200$ r.p.m.

$$\therefore 250 = \frac{\Phi \times 576 \times 1200}{6} \left(\frac{6}{12} \right); \quad \therefore \Phi = 0.0434 \text{ Wb}$$

(b) Inner diameter of the pole shoe circle is $= 350 + 6 = 356$ mm.

Since there are 6 poles, the net field pole flux coverage is 80% of one-sixth of the pole shoe circle. Hence, the effective pole arc length is

$$= \frac{1}{6} \times \pi d \times 0.8 = \frac{1}{6} \times \pi \times 356 \times 0.8 = 149 \text{ mm} = 0.149 \text{ m.}$$

(c) Pole surface area = pole shoe arc \times axial length of the pole (Fig. 26.60).

$$= 0.149 \times 0.260 = 0.03874 \text{ m}^2$$

$$\therefore \text{Flux density } B = 0.0434/0.03874 = 1.12 \text{ T}$$

Example 26.21(b). A 4-pole d.c. Generator with 1200 conductors generates 250 volts on open circuit, when driven at 500 rpm. The pole-shoes have a bore of 35 cm and the ratio of pole-arc to pole pitch is 0.7, while, the length of the pole shoe is 20 cm. Find the mean flux density in the airgap.

(Bharthiar Univ. Nov. 1972 & April 1998)

Solution. For a diameter of 35, 4-pole machine has a pole-pitch of $(35\pi/4) = 27.5$ cm

Since pole-arc/pole pitch is 0.7, Pole-arc $= 0.7 \times 27.5 = 19.25$ cm

Pole area $= 19.25 \times 20 = 385$ sq. cm.

Substituting in the e.m.f. equation, $250 = (\phi ZN/60) (p/a)$

For Lap-winding, in the case, $p = a = 4$

Hence, flux/pole $= (250 \times 60)/(1200 \times 500) = 0.025$ Wb

This flux is uniformly distributed over the pole-area.

Mean flux density in the air-gap $= (0.025)/(385 \times 10^{-4}) = 0.65 \text{ Wb/m}^2$

Example 26.21(c). A four-pole lap-wound dc shunt generator having 80 slots with 10 conductors per slot generates at no-load an e.m.f. of 400 V, when run at 1000 rpm. How will you obtain a generated open-circuit voltage of 220 V?

(Nagpur University November 1996)

Solution. (i) Keeping operating speed at 1000 rpm only, **change the flux per pole**

The O.C. e.m.f. is given by $E = (\phi ZN/60) \times (P/a)$

For the given operating conditions,

$$400 = \phi \times (80 \times 10) \times (1000/60) \times (4/4)$$

which gives $\phi = 30 \text{ mWb}$

When speed is kept constant at 1000 rpm only,

$$E \propto \phi$$

Or to get 220 V on O.C., $\phi_2 = (220/400) \times 30 \text{ mWb} = 16.5 \text{ mWb}$

Thus, by increasing the shunt-field-circuit resistance with the help of adding external rheostatic, the current in the field-circuit is decreased so as to decrease the flux to 16.5 mWb.

(ii) Keep same flux per pole, change the speed.

If ϕ is held constant at 30 mWb, an O.C. e.m.f. of 220 V is obtained at a speed of N r.p.m., given by

$$220 = 30 \times 10^{-3} \times 800 \times N/60, N = 550 \text{ rpm}$$

At 220 V, the flux can be maintained at 30 mWb provided the field **current is unchanged.**

$$400/R_{f1} = 200/R_{f2}$$

or $R_{f2} = 0.55 R_{f1}$

Thus, the field circuit resistance must be reduced to the new value of $0.55 R_{f1}$ in order to obtain 30 mWb of flux per pole from a voltage of 220 V.

(iii) Any other combination of proper speed and flux/pole can be chosen and worked out on similar lines.

Example 26.21(d). A short-shunt d.c. compound generator supplies 200 A at 100 V. The resistance of armature, series field and shunt field windings are 0.04, 0.03 and 60 ohms respectively. Find the emf generated. Also find the emf generated if same machine is connected as a long-shunt machine. (Nagpur University, April 1998)

Solution. With short-shunt connection, shown in Fig. 26.61 (a).

$$V_a = \text{armature terminal voltage} = 100 (200 \times 0.03) = 106 \text{ V}$$

$$\text{Shunt field current} = 106/60 = 1.767 \text{ amp}$$

$$\text{Armature current} = I_a = 200 + 1.767 = 201.767 \text{ amp}$$

$$\text{Armature induced e.m.f.} = 106 + (201.767 \times 0.04) = 114.07 \text{ volts}$$

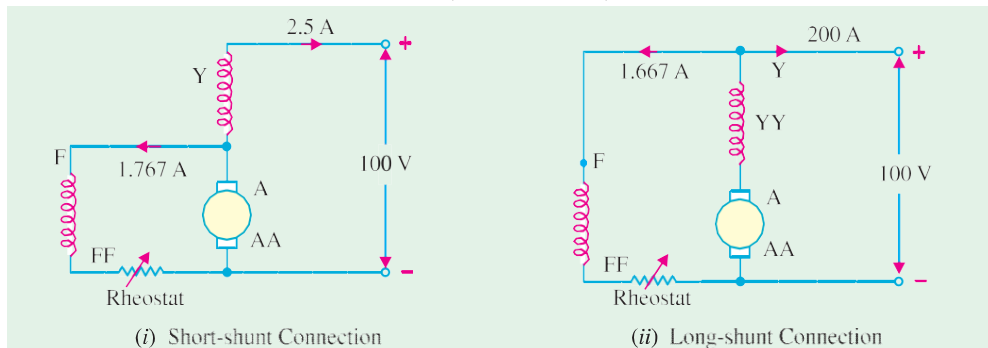

Fig. 26.61(a)

Now, with long-shunt connection shown in Fig. 26.61 (b),

$$\text{Shunt field current} = 100/60 = 1.667 \text{ amp}$$

$$\text{Armature current} = 201.667 \text{ amp}$$

Total voltage drop in armature and series field winding

$$= 201.667 (0.04 + 0.03) = 14.12 \text{ volts}$$

$$\text{Armature induced e.m.f.} = 100 + 14.12 = 114.12 \text{ volts}$$

Note : In case of long shunt connection, the generator has to develop the e.m.f. with shunt field current slightly reduced, compared to the case of short shunt connection. However, the series field winding carries a slightly higher current in latter case. Still, in practice, slight speed adjustment (or shunt field rheostatic variation) may be required to get this e.m.f., as per calculations done above.

Example 26.22. A long shunt dynamo running at 1000 r.p.m. supplies 20 kW at a terminal voltage of 220 V. The resistance of armature, shunt field, and series field are 0.04, 110 and 0.05 ohm respectively. Overall efficiency at the above load is 85%. Find :

- (i) Copper loss,
- (ii) Iron and friction loss,
- (iii) Torque developed by the prime mover.

(Amravati University 1999)

Solution. I_L , Load current = $\frac{20,000}{220} = 90.91$ amp

Shunt field current, $I_f = \frac{220}{110} = 2$ amp

Armature current, $I_a = 92.91$ amp

Input power = $20,000/0.85 = 23529$ watts

Total losses in the machine = Input – Output = $23529 - 20,000 = 3529$ watts

(i) Copper losses :

Power loss in series field-winding + armature winding = $92.91^2 \times 0.09$ watts = 777 watts

Power-loss in shunt field circuit : $2^2 \times 110 = 440$ watts

Total copper losses = $777 + 400 = 1217$ watts

(ii) Iron and friction losses = Total losses – Copper losses
 = $3529 - 1217 = 2312$ watts

(iii) Let T = Torque developed by the prime-mover

At 1000 r.p.m., angular speed, $\omega = 2\pi \times 1000/60 = 104.67$ rad./sec

$$T \times \omega = \text{Input power}$$

$$\therefore T = 23529/104.67 = 224.8 \text{ Nw-m}$$

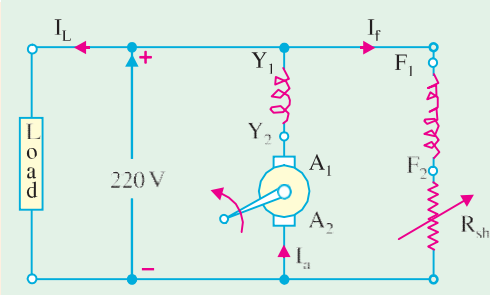

Fig. 26.61(b)

Iron Loss in Armature

Due to the rotation of the iron core of the armature in the magnetic flux of the field poles, there are some losses taking place continuously in the core and are known as Iron Losses or Core Losses. Iron losses consist of **(i) Hysteresis** loss and **(ii) Eddy Current** loss.

(i) Hysteresis Loss (W_h)

This loss is due to the reversal of magnetisation of the armature core. Every portion of the rotating core passes under N and S pole alternately, thereby attaining S and N polarity respectively. The core undergoes one complete cycle of magnetic reversal after passing under one pair of poles. If P is the number of poles and N , the armature speed in r.p.m., then frequency of magnetic reversals is $f = PN/120$.

The loss depends upon the volume and grade of iron, maximum value of flux density B_{max} and frequency of magnetic reversals. For normal flux densities (*i.e.* upto 1.5 Wb/m^2), hysteresis loss is given by **Steinmetz** formula. According to this formula,

$$W_h = \eta B_{max}^{1.6} f V \text{ watts}$$

where $V =$ volume of the core in m^3

$\eta =$ Steinmetz hysteresis coefficient.

Value of η for :

Good dynamo sheet steel = 502 J/m³, Silicon steel = 191 J/m², Hard Cast steel = 7040 J/m³, Cast steel = 750 – 3000 J/m³ and Cast iron = 2700 – 4000 J/m³.

(ii) Eddy Current Loss (W_e)

When the armature core rotates, it also cuts the magnetic flux. Hence, an e.m.f. is induced in the body of the core according to the laws of electromagnetic induction. This e.m.f. though small, sets up large current in the body of the core due to its small resistance. This current is known as eddy current. The power loss due to the flow of this current is known as eddy current loss. This loss would be considerable if solid iron core were used. In order to reduce this loss and the consequent heating of the core to a small value, the core is built up of thin laminations, which are stacked and then riveted at right angles to the path of the eddy currents. These core laminations are insulated from each other by a thin coating of varnish.

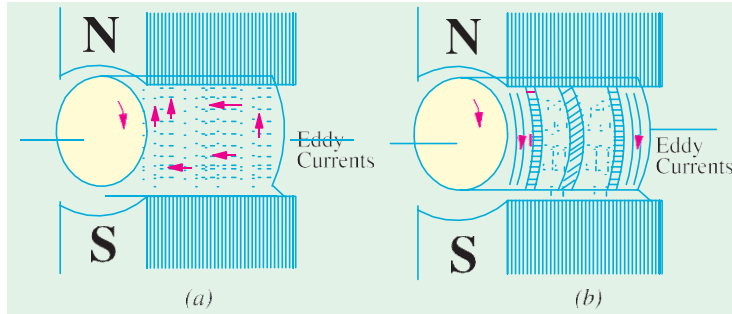

Fig. 26.62

The effect of laminations is shown in Fig. 26.62. Due to the core body being one continuous solid iron piece [Fig. 26.62 (a)], the magnitude of eddy currents is large. As armature cross-sectional area is large, its resistance is very small, hence eddy current loss is large. In Fig. 26.62 (b), the same core has been split up into thin circular discs insulated from each other. It is seen that now each current path, being of much less cross-section, has a very high resistance. Hence, magnitude of eddy currents is reduced considerably thereby drastically reducing eddy current loss.

It is found that eddy current loss W_e is given by the following relation :

$$W_e = KB_{\max}^2 f^2 t^2 V^2 \text{ watt}$$

where B_{\max} = maximum flux density f = frequency of magnetic reversals
 t = thickness of each lamination V = volume of armature core.

It is seen from above that this loss varies directly as the square of the thickness of laminations, hence it should be kept as small as possible. Another point to note is that $W_h \propto f$ but $W_e \propto f^2$. This fact makes it possible to separate the two losses experimentally if so desired.

As said earlier, these iron losses if allowed to take place unchecked not only reduce the efficiency of the generator but also raise the temperature of the core. As the output of the machines is limited, in most cases, by the temperature rise, these losses have to be kept as small as is economically possible.

Eddy current loss is reduced by using laminated core but hysteresis loss cannot be reduced this way. For reducing the hysteresis loss, those metals are chosen for the armature core which have a low hysteresis coefficient. Generally, special silicon steels such as stalloys are used which not only have a low hysteresis coefficient but which also possess high electrical resistivity.

Total Loss in a D.C. Generator

The various losses occurring in a generator can be sub-divided as follows :

(a) Copper Losses

(i) Armature copper loss = $I_a^2 R_a$

[Note : $E I_g$ is the power output from armature.]

where R_a = resistance of armature and interpoles and series field winding etc.

This loss is about 30 to 40% of full-load losses.

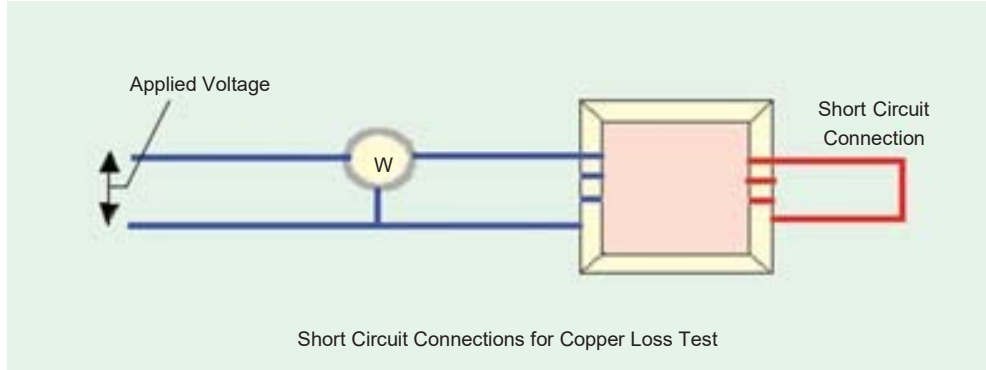

- (ii) Field copper loss. In the case of shunt generators, it is practically constant and $I_{sh}^2 R_{sh}$ (or VI_{sh}). In the case of series generator, it is $I_{se}^2 R_{se}$ where R_{se} is resistance of the series field winding.

This loss is about 20 to 30% of F.L. losses.

- (iii) The loss due to brush contact resistance. It is usually included in the armature copper loss.
(b) Magnetic Losses (also known as iron or core losses),

- (i) hysteresis loss, $W_h \propto B_{max}^{1.6} f$ and (ii) eddy current loss, $W_e \propto B_{max}^2 f^2$

These losses are practically constant for shunt and compound-wound generators, because in their case, field current is approximately constant.

Both these losses total up to about 20 to 30% of F.L. losses.

- (c) Mechanical Losses.** These consist of :

- (i) friction loss at bearings and commutator.
 (ii) air-friction or windage loss of rotating armature.

These are about 10 to 20% of F.L. Losses.

The total losses in a d.c. generator are summarized below :

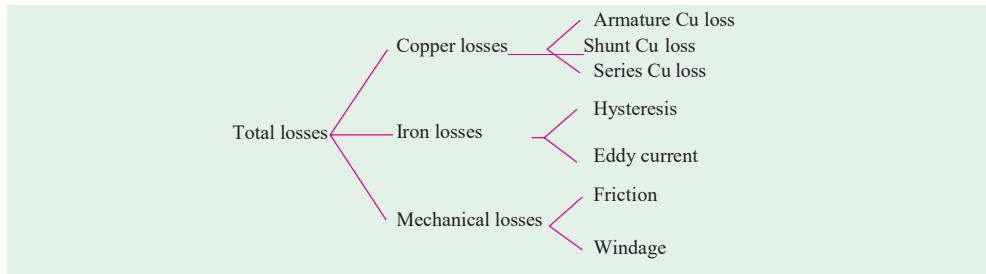

Stray Losses

Usually, magnetic and mechanical losses are collectively known as **Stray Losses**. These are also known as rotational losses for obvious reasons.

Constant or Standing Losses

As said above, field Cu loss is constant for shunt and compound generators. Hence, stray losses and shunt Cu loss are constant in their case. These losses are together known as standing or constant losses W_c .

Hence, for shunt and compound generators,

Total loss = armature copper loss + $W_c = I_a^2 R_a + W_c = (I + I_{sh})^2 R_a + W_c$.

Armature Cu loss $I_a^2 R_a$ is known as variable loss because it varies with the load current.

Total loss = variable loss + constant losses W_c

Power Stages

Various power stages in the case of a d.c. generator are shown below :

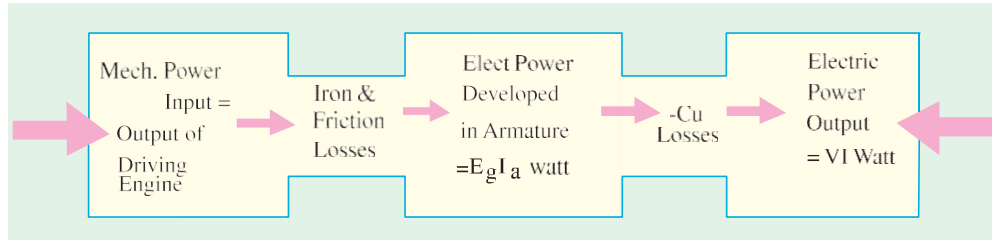

Following are the three generator efficiencies :

1. Mechanical Efficiency

$$\eta_m = \frac{B}{A} = \frac{\text{total watts generated in armature}}{\text{mechanical power supplied}} = \frac{E_g I_a}{\text{output of driving engine}}$$

2. Electrical Efficiency

$$\eta_e = \frac{C}{B} = \frac{\text{watts available in load circuit}}{\text{total watts generated}} = \frac{VI}{E_g I_a}$$

3. Overall or Commercial Efficiency

$$\eta_c = \frac{C}{A} = \frac{\text{watts available in load circuit}}{\text{mechanical power supplied}}$$

It is obvious that overall efficiency $\eta_c = \eta_m \times \eta_e$. For good generators, its value may be as high as 95%.

Note. Unless specified otherwise, commercial efficiency is always to be understood.

Condition for Maximum Efficiency

Generator output = VI

Generator input = output + losses

$$= VI + I_a^2 R_a + W_c = VI + (I + I_{sh})^2 R_a + W_c \quad (\because I_a = I + I_{sh})$$

However, if I_{sh} is negligible as compared to load current, then $I_a = I$ (approx.)

$$\therefore \eta = \frac{\text{output}}{\text{input}} = \frac{VI}{VI + I^2 R_a + W_c} \quad (\because I_a = I)$$

$$= \frac{1}{1 + \left(\frac{I R_a}{V} + \frac{W_c}{VI} \right)}$$

Now, efficiency is maximum when denominator is minimum i.e. when

$$\frac{d}{dI} \left(\frac{I R_a}{V} + \frac{W_c}{VI} \right) = 0 \quad \text{or} \quad \frac{R_a}{V} - \frac{W_c}{VI^2} = 0 \quad \text{or} \quad I^2 R_a = W_c$$

Hence, generator efficiency is maximum when

Variable loss = constant loss.

The load current corresponding to maximum efficiency is given by the relation.

$$I^2 R_a = W_c \quad \text{or} \quad I = \sqrt{\frac{W_c}{R_a}}$$

Variation of η with load current is shown in Fig. 26.63.

Example 26.23. A 10 kW, 250 V, d.c., 6-pole shunt generator runs at 1000 r.p.m. when delivering full-load. The armature has 534 lap-connected conductors. Full-load Cu loss is 0.64 kW. The total brush drop is 1 volt. Determine the flux per pole. Neglect shunt current.

(Elect. Engg. & Electronics, M.S. Univ./Baroda 1987)

Solution. Since shunt current is negligible, there is no shunt Cu loss. The copper loss occurs in armature only.

$$I = I_a = 10,000/250 = 40 \text{ A}; \quad I_a^2 R_a = \text{Arm. Cu loss} \quad \text{or} \quad 40^2 \times R_a = 0.64 \times 10^3; \quad R_a = 0.4 \Omega$$

$$I_a R_a \text{ drop} = 0.4 \times 40 = 16 \text{ V}; \quad \text{Brush drop} = 2 \times 1 = 2 \text{ V}$$

$$\therefore \text{Generated e.m.f.} \quad E_g = 250 + 16 + 1 = 267 \text{ V}$$

$$\text{Now, } E_g = \frac{\Phi Z N}{60} \left(\frac{P}{A} \right) \text{ volt} \quad \therefore 267 = \frac{\Phi \times 534 \times 1000}{60} \left(\frac{6}{6} \right) \quad \therefore \Phi = 30 \times 10^{-3} \text{ Wb} = \mathbf{30 \text{ mWb}}$$

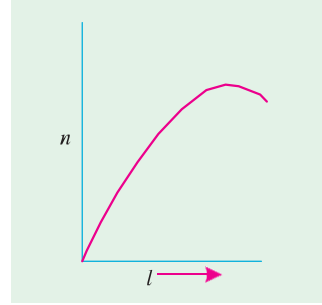

Fig. 26.63

Example 26.24(a). A shunt generator delivers 195 A at terminal p.d. of 250 V. The armature resistance and shunt field resistance are 0.02 Ω and 50 Ω respectively. The iron and friction losses equal 950 W. Find

- (a) E.M.F. generated (b) Cu losses (c) output of the prime motor
(d) commercial, mechanical and electrical efficiencies.

(Elect. Machines-I, Nagpur Univ. 1991)

Solution. (a) $I_{sh} = 250/50 = 5 \text{ A}; \quad I_a = 195 + 5 = 200 \text{ A}$

Armature voltage drop = $I_a R_a = 200 \times 0.02 = 4 \text{ V}$

\therefore Generated e.m.f. = $250 + 4 = \mathbf{254 \text{ V}}$

(b) Armature Cu loss = $I_a^2 R_a = 200^2 \times 0.02 = 800 \text{ W}$

Shunt Cu loss = $V I_{sh} = 250 \times 5 = 1250 \text{ W}$

\therefore Total Cu loss = $1250 + 800 = \mathbf{2050 \text{ W}}$

(c) Stray losses = 950 W; Total losses = $2050 + 950 = 3000 \text{ W}$

Output = $250 \times 195 = 48,750 \text{ W}$; Input = $48,750 + 3000 = 51,750 \text{ W}$

\therefore Output of prime mover = $\mathbf{51,750 \text{ W}}$

(d) Generator input = 51,750 W; Stray losses = 950 W

Electrical power produced in armature = $51,750 - 950 = 50,800$

$\eta_m = (50,800/51,750) \times 100 = \mathbf{98.2\%}$

Electrical or Cu losses = 2050 W

$\therefore \eta_e = \frac{48,750}{48,750 + 2,050} \times 100 = \mathbf{95.9\%}$

and $\eta_c = (48,750/51,750) \times 100 = \mathbf{94.2\%}$

Example 26.24(b). A 500 V, D.C. shunt motor draws a line current of 5 amps, on light load. If armature resistance is 0.15 ohm, and field resistance is 200 ohms, determine the efficiency of the machine running as a generator, delivering a load current of 40 Amp.

(Bharathiar Univ. Nov. 1997)

Solution. (i) As a motor, on Light load, out of 5 Amps of line current, 2.5 Amps are required for field circuit and 2.5 Amps are required for field circuit and 2.5 Amps are required for armature. Neglecting copper-loss in armature at no load (since it works out to be just one watt), the armature-power goes towards armature-core-loss and no-load mechanical loss at the rated speed. This amounts to $(500 \times 2.5) = 1250$ watts.

(ii) As a generator, for a line current of 40 Amp, the total current for the armature is 42.5 amp. Output of generator = $500 \times 40 \times 10^{-3} = 20$ kW

$$\begin{aligned} \text{Total losses as a generator} &= 1250 + \text{field copper-loss} + \text{arm. copper-loss} \\ &= (1250 + 1250 + 42.5^2 \times 0.15) \text{ watts} = 2.771 \text{ kW} \\ \text{Efficiency} &= \frac{20}{20 + 2.771} \times 100 = 87.83\% \end{aligned}$$

Example 26.25. A shunt generator has a F.L. current of 196 A at 220 V. The stray losses are 720 W and the shunt field coil resistance is 55 Ω. If it has a F.L. efficiency of 88%, find the armature resistance. Also, find the load current corresponding to maximum efficiency.

(Electrical Technology Punjab Univ. Nov. 1988)

Solution. Output = $220 \times 196 = 43,120$ W ; $\eta = 88\%$ (overall efficiency)
 Electrical input = $43,120 / 0.88 = 49,000$ W
 Total losses = $49,000 - 43,120 = 5,880$ W
 Shunt field current = $220 / 55 = 4$ A $\therefore I_a = 196 + 4 = 200$ A
 \therefore Shunt Cu loss = $220 \times 4 = 880$ W ; Stray losses = 720 W
 Constant losses = $880 + 720 = 1,600$
 \therefore Armature Cu loss = $5,880 - 1,600 = 4,280$ W
 $\therefore I_a^2 R_a = 4,280$ W
 $200^2 R_a = 4,280$ or $R_a = 4,280 / 200 \times 200 = 0.107 \Omega$

For maximum efficiency,

$$I_a^2 R_a = \text{constant losses} = 1,600 \text{ W ; } I = \sqrt{1,600 / 0.107} = 122.34 \text{ A}$$

Example 26.26. A long-shunt dynamo running at 1000 r.p.m. supplies 22 kW at a terminal voltage of 220 V. The resistances of armature, shunt field and the series field are 0.05, 110 and 0.06 Ω respectively. The overall efficiency at the above load is 88%. Find (a) Cu losses (b) iron and friction losses (c) the torque exerted by the prime mover.

(Elect. Machinery-I, Bangalore Univ. 1987)

Solution. The generator is shown in Fig. 26.64.

$$\begin{aligned} I_{sh} &= 220 / 110 = 2 \text{ A} \\ I &= 22,000 / 220 = 100 \text{ A}, \\ I_a &= 102 \text{ A} \\ \text{Drop in series field winding} &= 102 \times 0.06 = 6.12 \text{ V} \\ \text{(a) } I_a^2 R_a &= 102^2 \times 0.05 = 520.2 \text{ W} \\ \text{Series field loss} &= 102^2 \times 0.06 = 624.3 \text{ W} \\ \text{Shunt field loss} &= 4 \times 110 = 440 \text{ W} \end{aligned}$$

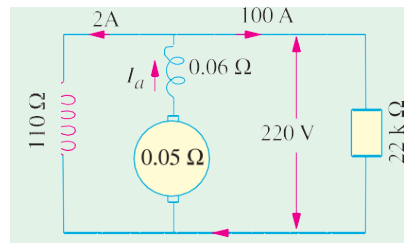

Fig. 26.64

Total Cu losses = 520.2 + 624.3 + 440 = **1584.5 W**

(b) Output = 22,000 W ; Input = 22,000/0.88 = 25,000 W

∴ Total losses = 25,000 – 22,000 = 3,000 W

∴ Iron and friction losses = 3,000 – 1,584.5 = **1,415.5 W**

Now, $T \times \frac{2\pi N}{60} = 25,000$; $T = \frac{25,000 \times 60}{1,000 \times 6.284} = \mathbf{238.74 \text{ N-m}}$

Example 26.27. A 4-pole d.c. generator is delivering 20 A to a load of 10 Ω . If the armature resistance is 0.5 Ω and the shunt field resistance is 50 Ω, calculate the induced e.m.f. and the efficiency of the machine. Allow a drop of 1 V per brush.

(Electrical Technology-I, Osmania Univ., 1990)

Solution. Terminal voltage = 20 × 10 = 200 V

$I_{sh} = 200/50 = 4 \text{ A}$; $I_a = 20 + 4 = 24 \text{ A}$

$I_a R_a = 24 \times 0.5 = 12 \text{ V}$; Brush drop = 2 × 1 = 2 V

∴ $E_g = 200 + 12 + 2 = \mathbf{214 \text{ V}}$, as in Fig. 26.65.

Since iron and friction losses are not given, only electrical efficiency of the machine can be found out.

Total power generated in the armature

= 214 × 24 = 5,136 W

Useful output = 200 × 20 = 4,000 W

∴ $\eta_e = 4,000/5,136 = 0.779$ or **77.9%**

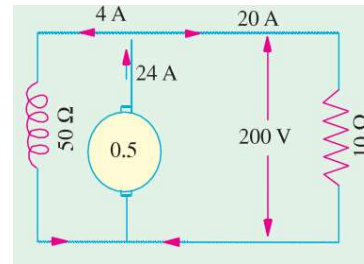

Fig. 26.65

Example 26.28. A long-shunt compound-wound generator gives 240 volts at F.L. output of 100 A. The resistances of various windings of the machine are : armature (including brush contact) 0.1 Ω, series field 0.02 Ω, interpole field 0.025 Ω, shunt field (including regulating resistance) 100 Ω. The iron loss at F.L. is 1000 W ; windage and friction losses total 500 W. Calculate F.L. efficiency of the machine.

(Electrical Machinery-I, Indore Univ. 1989)

Solution. Output = 240 × 100 = 24,000 W

Total armature circuit resistance = 0.1 + 0.02 + 0.025 = 0.145 Ω

$I_{sh} = 240/100 = 2.4 \text{ A}$ ∴ $I_a = 100 + 2.4 = 102.4 \text{ A}$

∴ Armature circuit copper loss = 102.4² × 0.145 = 1,521 W

Shunt field copper loss = 2.4 × 240 = 576 W

Iron loss = 1000 W ; Friction loss = 500 W

Total loss = 1,521 + 1,500 + 576 = 3,597 W ; $\eta = \frac{24,000}{24,000 + 3,597} = 0.87 = \mathbf{87\%}$

Example 26.29. In a d.c. machine the total iron loss is 8 kW at its rated speed and excitation. If excitation remains the same, but speed is reduced by 25%, the total iron loss is found to be 5 kW. Calculate the hysteresis and eddy current losses at (i) full speed (ii) half the rated speed.

(Similar Example, JNTU, Hyderabad, 2000)

Solution. We have seen in Art. 26.32 that

$W_h \propto f$ and $W_e \propto f^2$

Since f , the frequency of reversal of magnetization, is directly proportional to the armature speed,

$W_h \propto N$ and $W_e \propto N^2$

∴ $W_h = A \times N$ and $W_e = BN^2$, where A and B are constants.
 Total loss $W = W_h + W_e = AN + BN^2$

Let the full rated speed be 1.

$$\text{Then } 8 = A \times 1 + B \times 1^2 \text{ or } 8 = A + B \quad \dots(i)$$

Now, when speed is 75% of full rated speed, then

$$5 = A \times (0.75) + B(0.75)^2 \quad \dots(ii)$$

Multiplying (i) by 0.75 and subtracting (ii) from it, we get

$$0.1875 B = 1 \quad \therefore B = 1/0.1875 = 5.33$$

kW

Substituting this value in (i) above

$$8 = 5.33 + A \quad \therefore A = 2.67 \text{ kW}$$

$$(i) \quad W_h \text{ at rated speed} = 2.67 \text{ kW}, \quad W_e \text{ at rated speed} = 5.33 \text{ kW}$$

$$(ii) \quad W_h \text{ at half the rated speed} = 2.67 \times 0.5 = 1.335 \text{ kW}$$

$$W_e \text{ at half the rated speed} = 5.33 \times 0.5^2 = 1.3325 \text{ kW}$$

Example 26.30. The hysteresis and eddy current losses in a d.c. machine running at 1000 r.p.m. are 250 W and 100 W respectively. If the flux remains constant, at what speed will be total iron losses be halved? **(Electrical Machines-I, Gujarat Univ. 1989)**

Solution. Total loss $W = W_h + W_e = AN + BN^2$

Now, $W_h = 250 \text{ W} \quad \therefore A \times (1000/60) = 250; \quad A = 15$

$$W_e = 100 \text{ W} \quad \therefore B \times (1000/60)^2 = 100; \quad B = 9/25$$

Let N be the new speed in r.p.s. at which total loss is one half of the loss at 1000 r.p.m. New loss = $(250 + 100)/2 = 175 \text{ W}$

$$\therefore 175 = 15N + (9/25)N^2 \text{ or } 9N^2 + 375N - 4,375 = 0$$

$$\therefore N = \frac{-375 \pm \sqrt{375^2 + 36 \times 4,375}}{2 \times 9} = \frac{-375 \pm 546}{18} = 9.5 \text{ r.p.s} = 570 \text{ r.p.m.}^*$$

Note. It may be noted that at the new speed, $W_h = 250 \times (570/100) = 142.5 \text{ W}$ and $W_e = 100 \times (570/1000)^2 = 32.5 \text{ W}$. Total loss = $142.5 + 32.5 = 175 \text{ W}$.

Example 26.31. A d.c. shunt generator has a full load output of 10 kW at a terminal voltage of 240 V. The armature and the shunt field winding resistances are 0.6 and 160 ohms respectively. The sum of the mechanical and core-losses is 500 W. Calculate the power required, in kW, at the driving shaft at full load, and the corresponding efficiency. **(Nagpur University November 99)**

Solution. Field current = $\frac{240}{160} = 1.5 \text{ amp}$, Load current = $\frac{10,000}{240} = 41.67 \text{ amp}$

Armature current = $41.67 + 1.5 = 43.17 \text{ amp}$

Field copper losses = 360 W, Armature copper losses = $43.17^2 \times 0.6 = 1118 \text{ W}$

Total losses in kW = $0.36 + 1,118 + 0.50 = 1,978 \text{ kW}$

Hence, Power input at the shaft = 11.978 kW

$$\text{Efficiency} = \frac{10}{11.978} \times 100\% = 83.5\%$$

* The negative value has been rejected—being mathematically absurd.

Example 26.32. A long shunt d.c. compound generator delivers 110 kW at 220 V.

If $r_a = 0.01$ ohm, $r_{se} = 0.002$ ohm, and shunt field has a resistance of 110 ohms, calculate the value of the induced e.m.f. (Bharathithasan University Nov. 1997)

Solution. Load current = $110 \times 1000/220 = 500$ A
 Shunt field current = $220/110 = 2$ A
 Armature current = 502 A
 $r_a + r_{se} = 0.012$ ohm
 $E_a = 220 + [502 \times (0.012)] = 226.024$ V

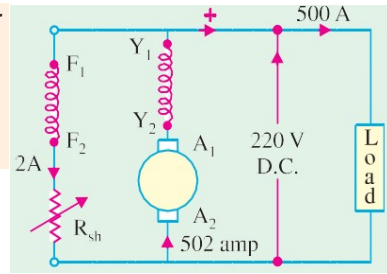

Fig. 26.66. Long-shunt d.c. compound generator

Example 26.33. The armature of a four-pole d.c. shunt generator is lap-wound and generates 216 V when running at 600 r.p.m. Armature has 144 slots, with 6 conductors per slot. If this armature is rewound, wave-connected, find the e.m.f. generated with the same flux per pole but running at 500 r.p.m. (Bharathithasan University April 1997)

Solution. Total number of armature conductors = $Z = 144 \times 6 = 864$

For a Lap winding, number of parallel paths in armature = number of poles

In the e.m.f. equation, $E = (\phi ZN/60) (P/a)$

Since $P = a$

$$E = \phi ZN/60$$

$$216 = \phi \times 864 \times 600/60 = 8640\phi$$

Hence $\phi = 25$ milli-webers

If the armature is rewound with wave-connection, number of parallel paths = 2.

Hence, at 500 r.p.m., with 25 mWb as the flux per pole.

$$\begin{aligned} \text{the armature emf} &= (25 \times 10^{-3} \times 864 \times 500/60) \times 4/2 \\ &= 25 \times 864 \times 0.50 \times 2/60 \\ &= 360 \text{ volts} \end{aligned}$$

Additional note :

Extension to Que : Comment on the armature output power in the two cases.

Solution. Assumption is that field side is suitably modified in the two cases.

Case (i) : Lap-wound Machine at 600 r.p.m.

Armature e.m.f.= 216 V

Let each armature-conductor be rated to carry a current of 10 amp.

In simple lap-wound machines, since a four-pole machine has four parallel paths in armature, the total armature output-current is 40 amp.

$$\text{Hence, armature-output-power} = 216 \times 40 \times 10^{-3} = 8.64 \text{ kW}$$

Case (ii) : Wave-wound machine, at 500 r.p.m.

Armature e.m.f. = 360 V

Due to wave-winding, number of parallel paths in armature = 2

Hence, the total armature output current = 20 amp

Thus, Armature Electrical output-power = $360 \times 20 \times 10^{-3} = 7.2 \text{ kW}$

Observation. With same flux per pole, the armature power outputs will be in the proportion of the speeds, as $(7.2/8.64) = 5/6$.

Further Conclusion. In case of common speed for comparing Electrical Outputs with same machine once lap-wound and next wave-wound, there is no difference in the two cases. Lap-wound machine has lower voltage and higher current while the wave-wound machine has higher voltage and lower current.

Example 26.34. A 4-pole, Lap-connected d.c. machine has an armature resistance of 0.15 ohm. Find the armature resistance of the machine is rewound for wave-connection.

(Bharthiar Univ. Nov. 1997)

Solution. A 4-pole lap-winding has 4 parallel paths in armature. If it is rewound for wave-connection, the resistance across the terminal becomes $(4 \times 0.15) = 0.6 \text{ ohm}$, as it obvious from Fig. 26.67.

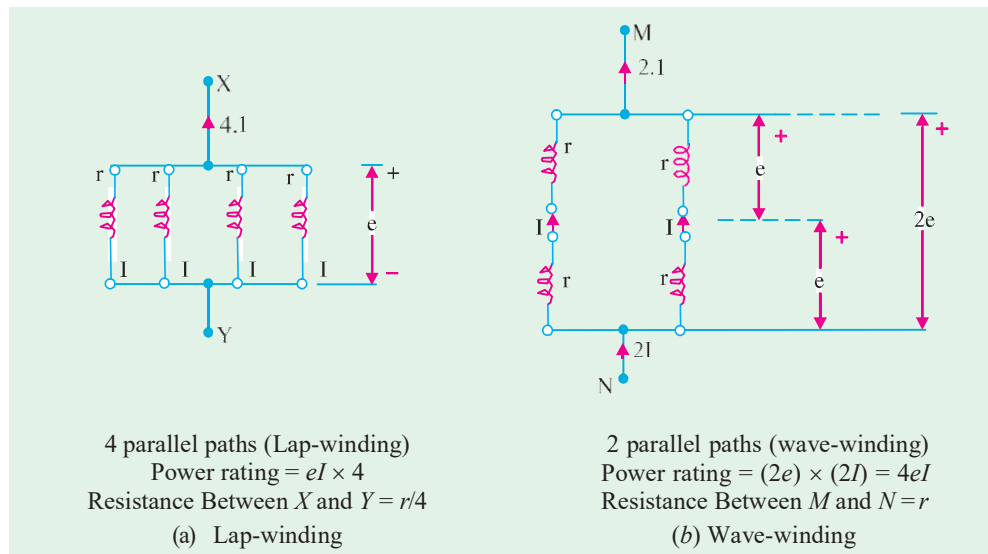

Fig. 26.67. Resistances for different methods

Tutorial Problem No. 26.2

1. A 4-pole, d.c. generator has a wave-wound armature with 792 conductors. The flux per pole is 0.0121 Wb. Determine the speed at which it should be run to generate 240 V on no-load. [751.3 r.p.m.]
2. A 20 kW compound generator works on full-load with a terminal voltage of 230 V. The armature, series and shunt field resistances are 0.1, 0.05 and 115 Ω respectively. Calculate the generated e.m.f. when the generator is connected short-shunt. [243.25 V] (Elect. Engg. Madras Univ. April, 1978)
3. A d.c. generator generates an e.m.f. of 520 V. It has 2,000 armature conductors, flux per pole of 0.013 Wb, speed of 1200 r.p.m. and the armature winding has four parallel paths. Find the number of poles. [4] (Elect. Technology, Aligarh Univ. 1978)
4. When driven at 1000 r.p.m. with a flux per pole of 0.02 Wb, a d.c. generator has an e.m.f. of 200 V. If the speed is increased to 1100 r.p.m. and at the same time the flux per pole is reduced to 0.019 Wb per pole, what is then the induced e.m.f. ? [209 V]

- 5 Calculate the flux per pole required on full-load for a 50 kW, 400 V, 8-pole, 600 r.p.m. d.c. shunt generator with 256 conductors arranged in a lap-connected winding. The armature winding resistances is 0.1Ω , the shunt field resistance is 200Ω and there is a brush contact voltage drop of 1 V at each brush on full-load. **[0.162 Wb]**
- 6 Calculate the flux in a 4-pole dynamo with 722 armature conductors generating 500 V when running at 1000 r.p.m. when the armature is (a) lap connected (b) wave connected. **[(a) 41.56 mWb (b) 20.78 mWb] (City & Guilds, London)**
- 7 A 4-pole machine running at 1500 r.p.m. has an armature with 90 slots and 6 conductors per slot. The flux per pole is 10 mWb. Determine the terminal e.m.f. as d.c. Generator if the coils are lap-connected. If the current per conductor is 100 A, determine the electrical power. **[810 V, 324 kW] (London Univ.)**
- 8 An 8-pole lap-wound d.c. generator has 120 slots having 4 conductors per slot. If each conductor can carry 250 A and if flux/pole is 0.05 Wb, calculate the speed of the generator for giving 240 V on open circuit. If the voltage drops to 220 V on full load, find the rated output of the machine. **[600 V, 440 kW]**
- 9 A 110-V shunt generator has a full-load current of 100 A, shunt field resistance of 55Ω and constant losses of 500 W. If F.L. efficiency is 88%, find armature resistance. Assuming voltage to be constant at 110 V, calculate the efficiency at half F.L. And at 50% overload. Find the load current. **[0.078 Ω ; 85.8% ; 96.2 A]**
- 10 A short-shunt compound d.c. Generator supplies a current of 100 A at a voltage of 220 V. If the resistance of the shunt field is 50Ω , of the series field 0.025Ω , of the armature 0.05Ω , the total brush drop is 2 V and the iron and friction losses amount to 1 kW, find
(a) the generated e.m.f. (b) the copper losses (c) the output power of the prime-mover driving the generator and (d) the generator efficiency. **[(a) 229.7 V (b) 1.995 kW (c) 24.99 kW (d) 88%]**
- 11 A 20 kW, 440-V, short-shunt, compound d.c. generator has a full-load efficiency of 87%. If the resistance of the armature and interpoles is 0.4Ω and that of the series and shunt fields 0.25Ω and 240Ω respectively, calculate the combined bearing friction, windage and core-loss of the machine. **[725 W]**
- 12 A long-shunt, compound generator delivers a load current of 50 A at 500 V and the resistances of armature, series field and shunt field are 0.05 ohm and 250 ohm respectively. Calculate the generated electromotive force and the armature current. Allow 1.0 V per brush for contact drop. **[506.2 V ; 52 A] (Elect. Engg. Banaras Hindu Univ. 1977)**
- 13 In a 110-V compound generator, the resistances of the armature, shunt and the series windings are Ω , 25Ω and 0.04Ω respectively. The load consists of 200 lamps each rated at 55 W, 110 V. Find the total electromotive force and armature current when the machine is connected (i) long shunt (ii) short shunt. Ignore armature reaction and brush drop. **[(a) 1200.4, 104.4 A (b) 120.3 V, 104.6 A] (Electrical Machines-I, Bombay Univ. 1979)**
- 14 Armature of a 2-pole, 200-V generator has 400 conductors and runs at 300 r.p.m. Calculate the useful flux per pole. If the number of turns in each field coil is 1200, what is the average value of e.m.f. induced in each coil on breaking the field if the flux dies away completely in 0.1 sec? **(JNTU, Hyderabad, 2000)**
- Hint:** Calculate the flux per pole generating 200 V at 300 rpm. Calculate the e.m.f. induced in 1200-turn field coil due to this flux reducing to zero in 0.1 sec, from the rate of change of flux-linkage. **[\(\phi = 0.1 \text{ Wb}, e = 1200 \text{ V}\)]**

15. A 1500 kW, 550-V, 16 pole generator runs at 150 rev. per min. What must be the useful flux if there are 2500 conductors lap-connected and the full-load copper losses are 25 kW? Calculate the area of the pole shoe if the gap density has a uniform value of 0.9 wb/m^2 and find the no-load terminal voltage, neglecting armature reaction and change in speed.

(Rajiv Gandhi Techn. Univ., Bhopal, 2000) [0.09944 m², 559.17 V]

OBJECTIVE TESTS – 26

- The basic requirement of a d.c. armature winding is that it must be
 - a closed one
 - a lap winding
 - a wave winding
 - either (b) or (c)
- A wave winding must go at least around the armature before it closes back where it started.
 - once
 - twice
 - thrice
 - four times
- The d.c. armature winding in which coil sides are a pole pitch apart is called winding.
 - multiplex
 - fractional-pitch
 - full-pitch
 - pole-pitch
- For making coil span equal to a pole pitch in the armature winding of a d.c. generator, the back pitch of the winding must equal the number of
 - commutator bars per pole
 - winding elements
 - armature conductors per path
 - armature parallel paths.
- The primary reason for making the coil span of a d.c. armature winding equal to a pole pitch is to
 - obtain a coil span of 180° (electrical)
 - ensure the addition of e.m.fs. of consecutive turns
 - distribute the winding uniformly under different poles
 - obtain a full-pitch winding.
- In a 4-pole, 35 slot d.c. armature, 180 electrical-degree coil span will be obtained when coils occupy slots.
 - 1 and 10
 - 1 and 9
 - 2 and 11
 - 3 and 12
- The armature of a d.c. generator has a 2-layer lap-winding housed in 72 slots with six conductors/slot. What is the minimum number of commutator bars required for the armature?
 - 72
 - 432
 - 216
 - 36
- The sole purpose of a commutator in a d.c. Generator is to
 - increase output voltage
 - reduce sparking at brushes
 - provide smoother output
 - convert the induced a.c. into d.c.
- For a 4-pole, 2-layer, d.c., lap-winding with 20 slots and one conductor per layer, the number of commutator bars is
 - 80
 - 20
 - 40
 - 160
- A 4-pole, 12-slot lap-wound d.c. armature has two coil-sides/slot. Assuming single turn coils and progressive winding, the back pitch would be
 - 5
 - 7
 - 3
 - 6
- If in the case of a certain d.c. armature, the number of commutator segments is found either one less or more than the number of slots, the armature must be having a simplex winding.
 - wave
 - lap
 - frog leg
 - multielement
- Lap winding is suitable for current, voltage d.c. generators.
 - high, low
 - low, high
 - low, low
 - high, high

13. The series field of a short-shunt d.c. generator is excited by currents.
(a) shunt
(b) armature
(c) load
(d) external
14. In a d.c. generator, the generated e.m.f. is directly proportional to the
(a) field current
(b) pole flux
(c) number of armature parallel paths
(d) number of dummy coils
15. In a 12-pole triplex lap-wound d.c. armature, each conductor can carry a current of 100 A. The rated current of this armature is ampere.
(a) 600
(b) 1200
(c) 2400
(d) 3600
16. The commercial efficiency of a shunt generator is maximum when its variable loss equals.....loss.
(a) constant
(b) stray
(c) iron
(d) friction and windage
17. In small d.c. machines, armature slots are sometimes not made axial but are skewed. Though skewing makes winding a little more difficult, yet it results in
(a) quieter operation
(b) slight decrease in losses
(c) saving of copper
(d) both (a) and (b)
18. The critical resistance of the d.c. generator is the resistance of
(a) armature
(b) field
(c) load
(d) brushes (Grad. I.E.T.E Dec. 1985)

ANSWERS

1. (a) 2. (b) 3. (c) 4. (a) 5. (b) 6. (b) 7. (c) 8. (d) 9. (b) 10. (b)
11. (a) 12. (a) 13. (c) 14. (b) 15. (d) 16. (a) 17. (d) 18. (b)