

Learning Objectives

- Basic Principle
- Stationary Armature
- Rotor
- Armature Windings
- Wye and Delta Connections
- Distribution or Breadth Factor or Winding Factor or Spread Factor
- Equation of Induced E.M.F.
- Factors Affecting Alternator Size
- Alternator on Load
- Synchronous Reactance
- Vector Diagrams of Loaded Alternator
- Voltage Regulation
- Rothert's M.M.F. or Ampere-turn Method
- Zero Power Factor Method or Potier Method
- Operation of Salient Pole Synchronous Machine
- Power Developed by a Synchronous Generator
- Parallel Operation of Alternators
- Synchronizing of Alternators
- Alternators Connected to Infinite Bus-bars
- Synchronizing Torque T_{sy}
- Alternative Expression for Synchronizing Power
- Effect of Unequal Voltages
- Distribution of Load
- Maximum Power Output
- Questions and Answers on Alternators

ALTERNATORS



 Alternator

Basic Principle

A.C. generators or alternators (as they are usually called) operate on the same fundamental principles of electromagnetic induction as d.c. generators. They also consist of an armature winding and a magnetic field. But there is one important difference between the two. Whereas in d.c. generators, the *armature rotates* and the field system is *stationary*, the arrangement in alternators is just the reverse of it. In their case, standard construction consists of armature winding mounted on a stationary element called *stator* and field windings on a rotating element called rotor. The details of construction are shown in Fig. 37.1.

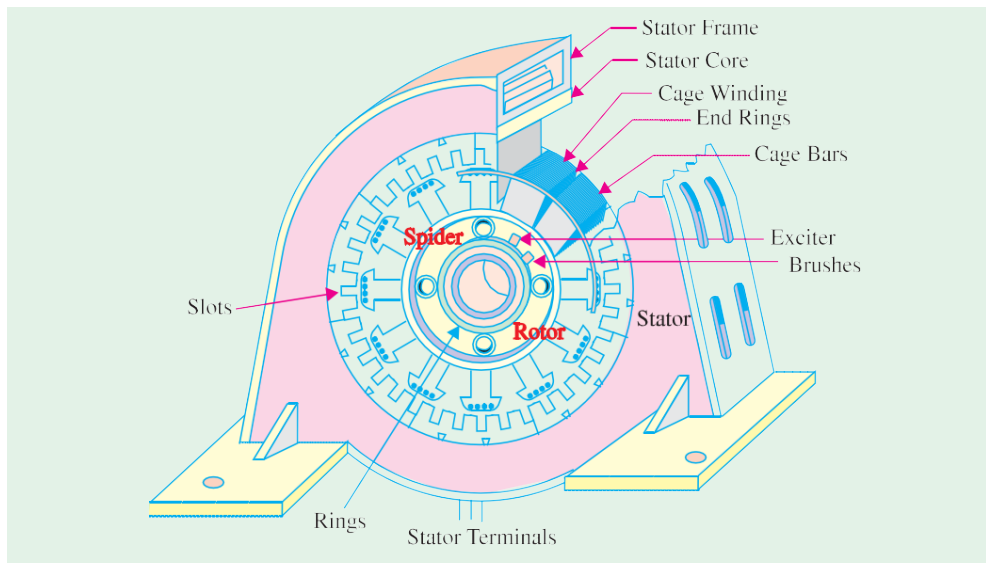
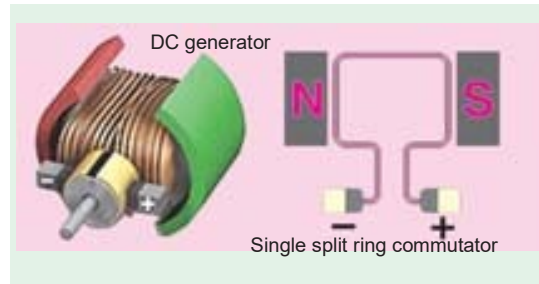

Fig. 37.1

The stator consists of a cast-iron frame, which supports the armature core, having slots on its inner periphery for housing the armature conductors. The rotor is like a flywheel having alternate *N* and *S* poles fixed to its outer rim. The magnetic poles are excited (or magnetised) from direct current supplied by a d.c. source at 125 to 600 volts. In most cases, necessary exciting (or magnetising) current is obtained from a small d.c. shunt generator which is belted or mounted on the shaft of the alternator itself. Because the field magnets are rotating, this current is supplied through two sliprings. As the exciting voltage is relatively small, the slip-rings and brush gear are of light construction. Recently, brushless excitation systems have been developed in which a 3-phase a.c. exciter and a group of rectifiers supply d.c. to the alternator. Hence, brushes, slip-rings and commutator are eliminated.

When the rotor rotates, the stator conductors (being stationary) are cut by the magnetic flux, hence they have induced e.m.f. produced in them. Because the magnetic poles are alternately *N* and *S*, they induce an e.m.f. and hence current in armature conductors, which first flows in one direction and then in the other. Hence, an alternating e.m.f. is produced in the stator conductors (*i*) whose frequency depends on the

number of N and S poles moving past a conductor in one second and (*ii*) whose direction is given by Fleming's Right-hand rule.

Stationary Armature

Advantages of having stationary armature (and a rotating field system) are :

1. The output current can be led directly from fixed terminals on the stator (or armature windings) to the load circuit, without having to pass it through brush-contacts.

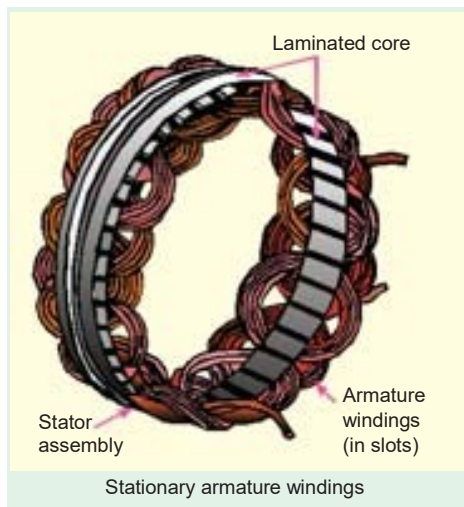

stampings and windings in position. Low-speed large-diameter alternators have frames which because of ease of manufacture, are cast in sections. Ventilation is maintained with the help of holes cast in the frame itself. The provision of radial ventilating spaces in the stampings assists in cooling the machine.

But, these days, instead of using castings, frames are generally fabricated from mild steel plates welded together in such a way as to form a frame having a box type section.

In Fig. 37.2 is shown the section through the top of a typical stator.

2 Stator Core

The armature core is supported by the stator frame and is built up of laminations of



2. It is easier to insulate stationary armature winding for high a.c. voltages, which may have as high a value as 30 kV or more.
3. The sliding contacts *i.e.* slip-rings are transferred to the low-voltage, low-power d.c. field circuit which can, therefore, be easily insulated.
4. The armature windings can be more easily braced to prevent any deformation, which could be produced by the mechanical stresses set up as a result of short-circuit current and the high centrifugal forces brought into play.

Details of Construction

1. Stator Frame

In d.c. machines, the outer frame (or yoke) serves to carry the magnetic flux but in alternators, it is not meant for that purpose. Here, it is used for holding the armature

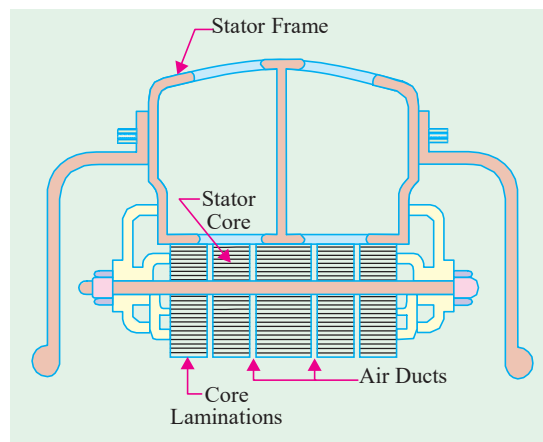

Fig. 37.2

special magnetic iron or steel alloy. The core is laminated to minimise loss due to eddy currents. The laminations are stamped out in complete rings (for smaller machines) or in segments (for larger machines). The laminations are insulated from each other and have spaces between them for allowing the cooling air to pass through. The slots for housing the armature conductors lie along the inner periphery of the core and are stamped out at the same time when laminations are formed. Different shapes of the armature slots are shown in Fig. 37.3.

The wide-open type slot (also used in d.c. machines) has the advantage of permitting easy installation of form-wound coils and their easy removal in case of repair. But it has the disadvantage of distributing the air-gap flux into bunches or tufts, that produce ripples in the wave of the generated e.m.f. The semi-closed type slots are better in this respect, but do not allow the use of form-wound coils. The wholly-closed type slots or tunnels do not disturb the air-gap flux but (i) they tend to increase the inductance of the windings (ii) the armature conductors have to be threaded through, thereby increasing initial labour and cost of winding and (iii) they present a complicated problem of end-connections. Hence, they are rarely used.



Streetbike stator

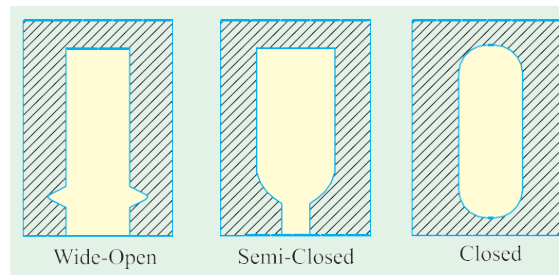
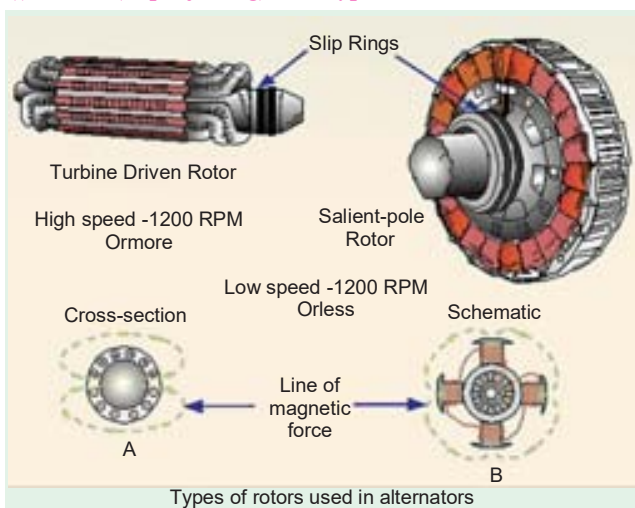

Fig. 37.3

Rotor

Two types of rotors are used in alternators (i) salient-pole type and (ii) smooth-cylindrical type.

(i) Salient (or projecting) Pole Type



Types of rotors used in alternators

It is used in low-and medium-speed (engine driven) alternators. It has a large number of projecting (salient) poles, having their cores bolted or dovetailed onto a heavy magnetic wheel of cast-iron, or steel of good magnetic quality (Fig. 37.4). Such generators are characterised by their large diameters and short axial lengths. The poles and pole-shoes (which cover 2/3 of pole-pitch) are laminated to minimize heating due to eddy currents. In large machines, field windings consist of rectangular copper strip wound on edge.

(ii) Smooth Cylindrical Type

It is used for steam turbine-driven alternators *i.e.* turbo-alternators, which run at very high speeds. The rotor consists of a smooth solid forged steel cylinder, having a number of slots milled out at intervals along the outer periphery (and parallel to the shaft) for accommodating field coils. Such rotors are designed mostly for 2-pole (or 4-pole) turbo-generators running at 3600 r.p.m. (or 1800 r.p.m.). Two (or four) regions corresponding to the central polar areas are left unslotted, as shown in Fig. 37.5 (a) and (b).

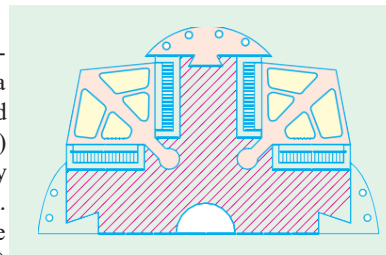

Fig. 37.4



Turbine alternator

The central polar areas are surrounded by the field windings placed in slots. The field coils are so arranged around these polar areas that flux density is maximum on the polar central line and gradually falls away on either side. It should be noted that in this case, poles are non-salient *i.e.* they do not project out from the surface of the rotor. To avoid excessive peripheral velocity, such rotors have very small diameters (about 1 metre or so). Hence, turbo-generators are characterised by small diameters and very long axial (or rotor) length. The cylindrical construction of the rotor gives better balance and

quieter-operation and also less windage losses.

Damper Windings

Most of the alternators have their pole-shoes slotted for receiving copper bars of a grid or damper winding (also known as squirrel-cage winding). The copper bars are short-circuited at both ends by heavy copper rings (Fig. 37.6). These dampers are useful in preventing the hunting (momentary speed fluctuations) in generators and are needed in synchronous motors to provide the starting torque. Turbo-generators usually do not have these damper windings (except in special case to assist in synchronizing) because the solid field-poles themselves act as efficient dampers. It should be clearly understood that under normal running conditions, damper winding does not carry any current because rotor runs at synchronous speed.

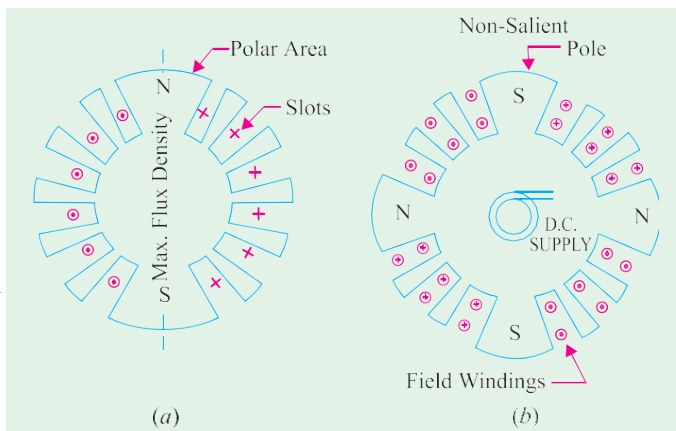

Fig. 37.5

The damper winding also tends to maintain balanced 3- ϕ voltage under unbalanced load conditions.

Speed and Frequency

In an alternator, there exists a definite relationship between the rotational speed (N) of the rotor, the frequency (f) of the generated e.m.f. and the number of poles P .

Consider the armature conductor marked X in Fig. 37.7 situated at the centre of a N -pole rotating in clockwise direction. The conductor being situated at the place of maximum flux density will have maximum e.m.f. induced in it.

The direction of the induced e.m.f. is given by Fleming’s right hand rule. But while applying this rule, one should be careful to note that the thumb indicates the direction of the motion of the conductor relative to the field. To an observer stationed on the clockwise revolving poles, the conductor would seem to be rotating anti-clockwise. Hence, thumb should point to the left. The direction of the induced e.m.f. is downwards, in a direction at right angles to the plane of the paper.

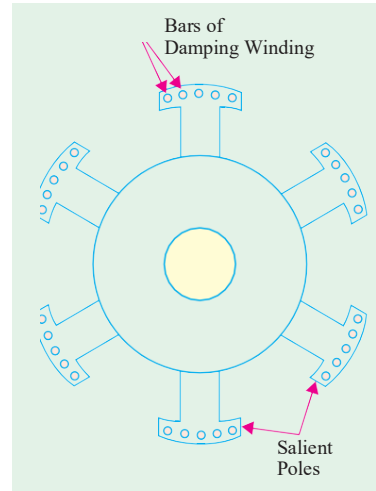

Fig. 37.6

When the conductor is in the interpolar gap, as at A in Fig. 37.7, it has minimum e.m.f. induced in it, because flux density is minimum there. Again, when it is at the centre of a S -pole, it has maximum e.m.f. induced in it, because flux density at B is maximum. But the direction of the e.m.f. when conductor is over a N -pole is opposite to that when it is over a S -pole.

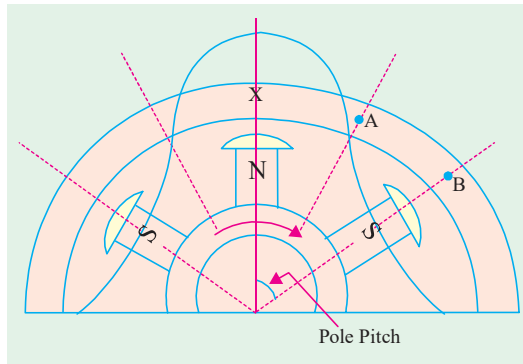

Fig. 37.7

Obviously, one cycle of e.m.f. is induced in a conductor when one pair of poles passes over it. In other words, the e.m.f. in an armature conductor goes through one cycle in angular distance equal to twice the pole-pitch, as shown in Fig. 37.7.

- Let P = total number of magnetic poles
- N = rotative speed of the rotor in r.p.m.
- f = frequency of generated e.m.f. in Hz.

Since one cycle of e.m.f. is produced when a pair of poles passes past a conductor, the number of cycles of e.m.f. produced in one revolution of the rotor is equal to the number of pair of poles.

$$\therefore \text{No. of cycles/revolution} = P/2 \text{ and No. of revolutions/second} = N/60$$

$$\therefore \text{frequency} = \frac{P}{2} \times \frac{N}{60} = \frac{PN}{120} \text{ Hz}$$

$$\text{or } f = \frac{PN}{120} \text{ Hz}$$

N is known as the synchronous speed, because it is the speed at which an alternator must run, in order to generate an e.m.f. of the required frequency. In fact, for a given frequency and given number of poles, the speed is fixed. For producing a frequency of 60 Hz, the alternator will have to run at the following speeds:

No. of poles	2	4	6	12	24	36
Speed (r.p.m.)	3600	1800	1200	600	300	200

Referring to the above equation, we get $P = 120f/N$

It is clear from the above that because of slow rotative speeds of engine-driven alternators, their number of poles is much greater as compared to that of the turbo-generators which run at very high speeds.

Armature Windings

The armature windings in alternators are different from those used in d.c. machines. The d.c. machines have closed circuit windings but alternator windings are open, in the sense that there is no closed path for the armature currents in the winding itself. One end of the winding is joined to the neutral point and the other is brought out (for a star-connected armature).

The two types of armature windings most commonly used for 3-phase alternators are :

- (i) single-layer winding
- (ii) double-layer winding

Single-layer Winding

It is variously referred to as concentric or chain winding. Sometimes, it is of simple bar type or wave winding.

The fundamental principle of such a winding is illustrated in Fig. 37.8 which shows a single-layer, one-turn, full-pitch winding for a four-pole generator. There are 12 slots in all, giving 3 slots per pole or 1 slot/phase/pole. The pole pitch is obviously 3. To get maximum e.m.f., two sides of a coil should be one pole-pitch apart *i.e.* coil span should be equal to one pole pitch. In other words, if one side of the coil is under the centre of a *N*-pole, then the other side of the same *coil* should be under the centre of a *S*-pole *i.e.* 180° (electrical) apart. In that case, the e.m.f.s. induced in the two sides of the coil are added together. It is seen from the above figure, that *R* phase starts at slot No. 1, passes through slots 4, 7 and finishes at 10. The *Y*-phase starts 120° afterwards *i.e.* from slot No. 3 which is two slots away from the start of *R*-phase (because when 3 slots correspond to 180° electrical degrees, two slots correspond to an angular displacement of 120° electrical). It passes through slots 6, 9 and finishes at 12. Similarly, *B*-phase starts from slot No.5 *i.e.* two slots away from the start of *Y*-phase. It passes through slots 8, 11 and finishes at slot No. 2. The developed diagram is shown in Fig. 37.9. The ends of the windings are joined to form a star point for a *Y*-connection.

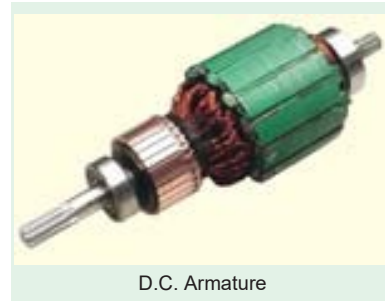

D.C. Armature

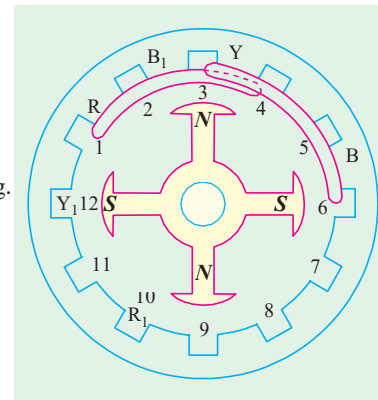
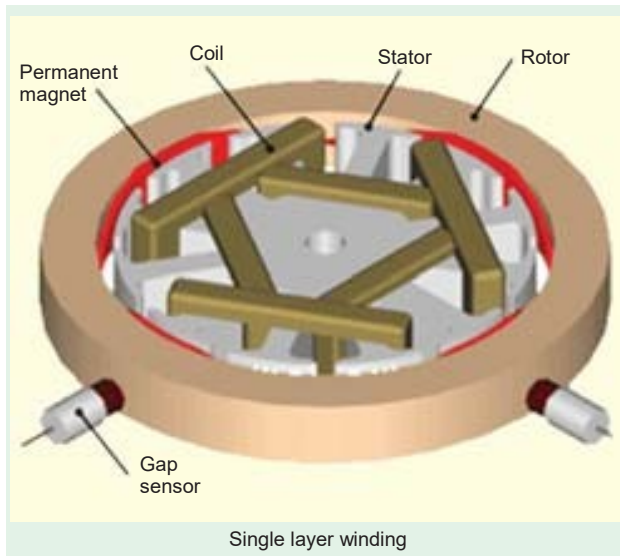

Fig. 37.8



Single layer winding

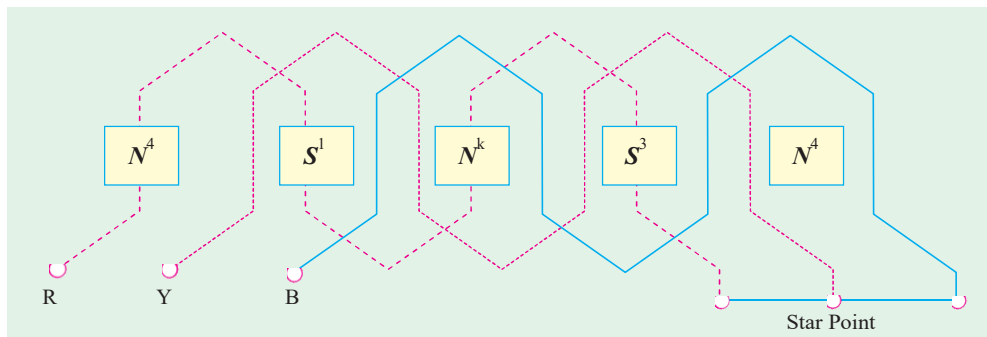

Fig. 37.9

Concentric or Chain Windings

For this type of winding, the number of slots is equal to twice the number of coils or equal to the number of coil sides. In Fig. 37.10 is shown a concentric winding for 3-phase alternator. It has one coil per pair of poles per phase.

It would be noted that the polar group of each phase is 360° (electrical) apart in this type of winding

1. It is necessary to use two different shapes of coils to avoid fouling of end connections.
2. Since polar groups of each phase are 360 electrical degrees apart, all such groups are connected in the same direction.
3. The disadvantage is that short-pitched coils cannot be used.

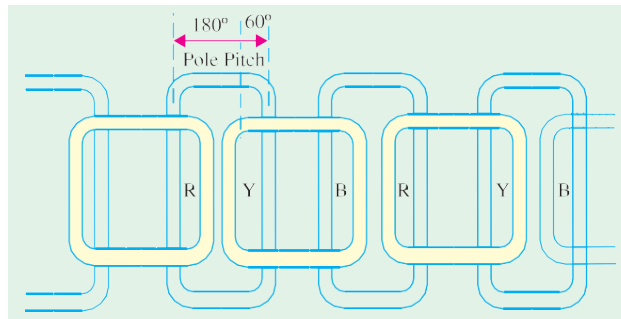

Fig. 37.10

In Fig. 37.11 is shown a concentric winding with two coils per group per pole. Different shapes of coils are required for this winding.

All coil groups of phase R are connected in the same direction. It is seen that in each group, one coil has a pitch of $5/6$ and the other has a pitch of $7/6$ so that pitch factor (explained later) is 0.966 . Such windings are used for large high-voltage machines.

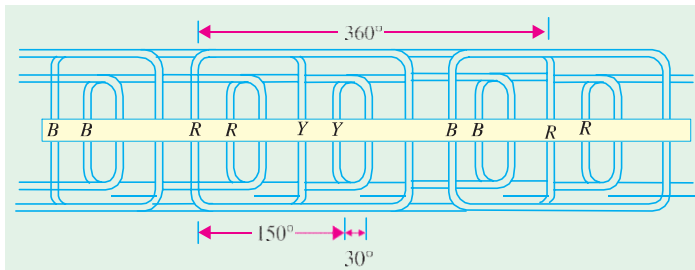

Fig. 37.11

Two-Layer Winding

This winding is either of wave-wound type or lap-wound type (this being much more common especially for high-speed turbo-generators). It is the simplest and, as said above, most commonly-used not only in synchronous machines but in induction motors as well.

Two important points regarding this winding should be noted :

- (a) Ordinarily, the number of slots in stator (armature) is a multiple of the number of poles and the number of phases. Thus, the stator of a 4-pole, 3-phase alternator may have 12, 24, 36, 48 etc. slots all of which are seen to be multiple of 12 (*i.e.* 4×3).
- (b) The number of stator slots is equal to the number of coils (which are all of the same shape). In other words, each slot contains two coil sides, one at the bottom of the slot and the other at the top. The coils overlap each other, just like shingles on a roof top.

For the 4-pole, 24-slot stator machine shown in Fig. 37.12, the pole-pitch is $24/4 = 6$. For maximum voltage, the coils should be full-pitched. It means that if one side of the coil is in slot No.1, the other side should be in slot No.7, the two slots 1 and 7 being one pole-pitch or 180° (electrical) apart. To make matters simple, coils have been labelled as 1, 2, 3 and 4 etc. In the developed diagram of Fig. 37.14, the coil number is the number of the slot in which the left-hand side of the coil is placed.

Each of the three phases has $24/3 = 8$ coils, these being so selected as to give maximum voltage when connected in series.

When connected properly, coils 1, 7, 13 and 19 will add directly in phase. Hence, we get 4 coils for this phase. To complete eight coils for this phase, the other four selected are 2, 8, 14 and 20 each of which is at an angular displacement of 30° (elect.) from the adjacent coils of the first. The coils 1 and 2 of this phase are said to constitute a polar group (which is defined as the group of coils/phase/pole). Other polar groups for this phase are 7 and 8, 13 and 14, 19 and 20 etc. After the coils are placed in slots, the polar groups are joined. These groups are connected together with alternate poles reversed (Fig. 37.13) which shows winding for one phase only.

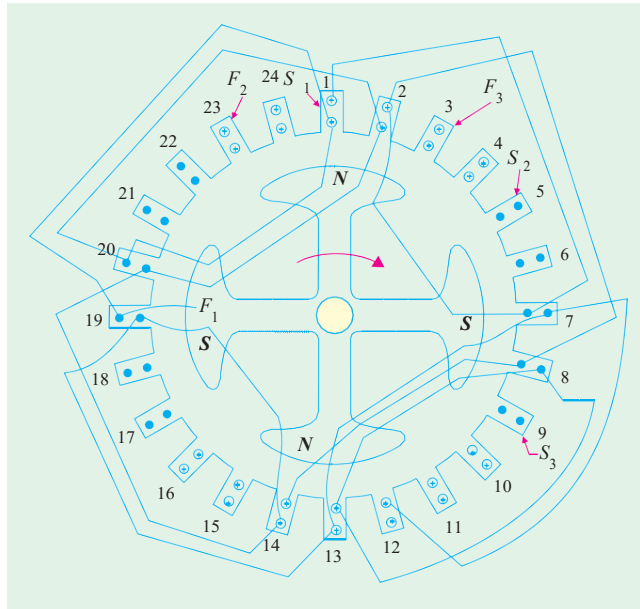

Fig. 37.12

Now, phase *Y* is to be so placed as to be 120° (elect.) away from phase *R*. Hence, it is started from slot 5 *i.e.* 4 slots away (Fig. 37.14). It should be noted that angular displacement between slot No. 1 and 5 is $4 \times 30 = 120^\circ$ (elect). Starting from coil 5, each of the other eight coils of phase *Y* will be placed 4 slots to the right of corresponding coils for phase *R*. In the same way, *B* phase will start from coil 9. The complete wiring diagram for three phases is shown in Fig. 37.14. The terminals R_2, Y_2 and B_2 may be connected together to form a neutral for *Y*-connection.

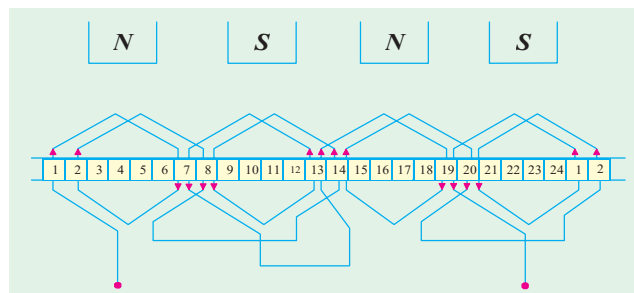

Fig. 37.13

The complete wiring diagram for three phases is shown in Fig. 37.14. The terminals R_2, Y_2 and B_2 may be connected together to form a neutral for *Y*-connection.

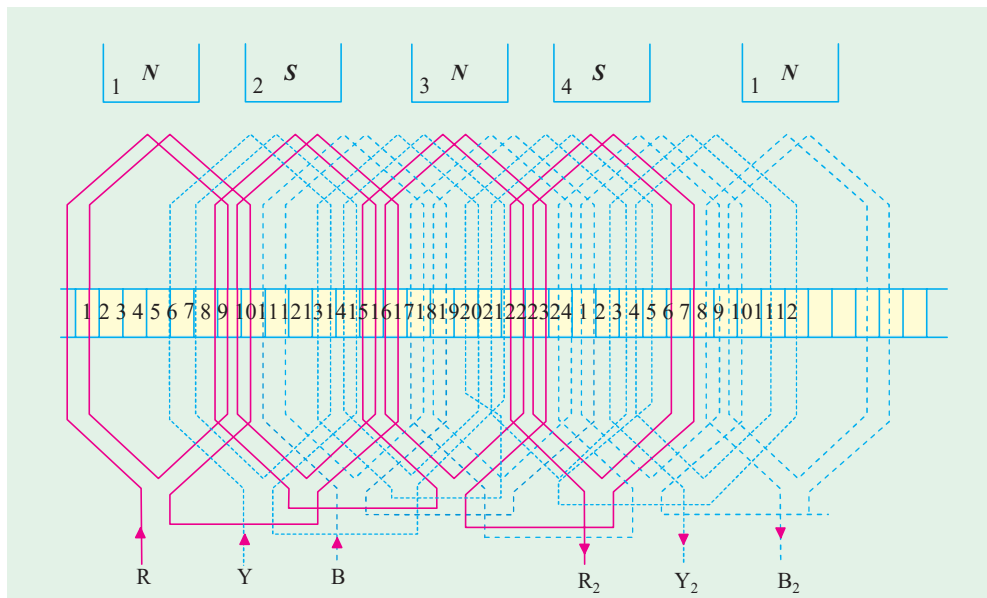

Fig. 37.14 (a)

A simplified diagram of the above winding is shown below Fig. 37.14. The method of construction for this can be understood by closely inspecting the developed diagram.

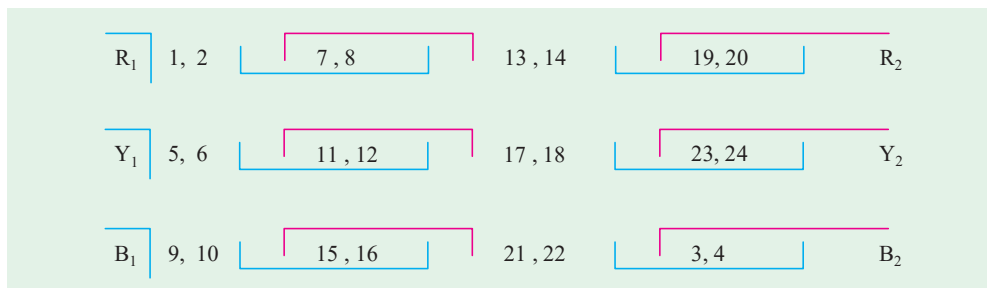

Fig. 37.14 (b)

Wye and Delta Connections

For *Y*-connection, R_1 , Y_1 and B_1 are joined together to form the star-point. Then, ends R_2 , Y_2 and B_2 are connected to the terminals. For delta connection, R_2 and Y_1 , Y_2 and B_1 , B_2 and R_1 are connected together and terminal leads are brought out from their junctions as shown in Fig. 37.15 (a) and (b).

Short-pitch Winding : Pitch factor/chording factor

So far we have discussed full-pitched coils *i.e.* coils having span which is equal to one pole-pitch *i.e.* spanning over 180° (electrical).

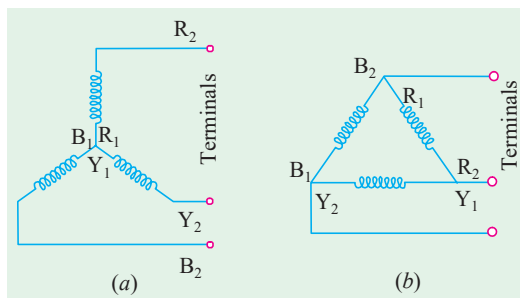

Fig. 37.15

As shown in Fig. 37.16, if the coil sides are placed in slots 1 and 7, then it is full-pitched. If the coil sides are placed in slots 1 and 6, then it is short-pitched or fractional-pitched because coil span is equal to 5/6 of a pole-pitch. It falls short by 1/6 pole-pitch or by $180^\circ/6 = 30^\circ$. Short-pitched coils are deliberately used because of the following advantages:

1. They save copper of end connections.
2. They improve the wave-form of the generated e.m.f. *i.e.* the generated e.m.f. can be made to approximate to a sine wave more easily and the distorting harmonics can be reduced or totally eliminated.
3. Due to elimination of high frequency harmonics, eddy current and hysteresis losses are reduced thereby increasing the efficiency.

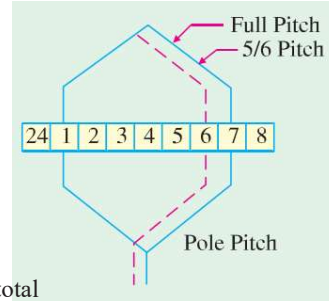

Fig. 37.16

But the disadvantage of using short-pitched coils is that the total voltage around the coils is somewhat reduced. Because the voltages induced in the two sides of the short-pitched coil are slightly out of phase, their resultant vectorial sum is less than their arithmetical sum.

The pitch factor or coil-span factor k_p or k_c is defined as
$$k_c = \frac{\text{vector sum of the induced e.m.fs. per coil}}{\text{arithmetic sum of the induced e.m.fs. per coil}}$$

It is always less than unity.

Let E_s be the induced e.m.f. in each side of the coil. If the coil were full-pitched *i.e.* if its two sides were one pole-pitch apart, then total induced e.m.f. in the coil would have been $= 2E_s$ [Fig. 37.17 (a)].

If it is short-pitched by 30° (elect.) then as shown in Fig. 37.17 (b), their resultant is E which is the vector sum of two voltage 30° (electrical) apart.

$$\begin{aligned} \therefore E &= 2 E_s \cos 30^\circ/2 = 2 E_s \cos 15^\circ \\ k_c &= \frac{\text{vector sum}}{\text{arithmetic sum}} = \frac{E}{2 E_s} = \frac{2 E_s \cos 15^\circ}{2 E_s} = \cos 15^\circ = 0.966 \end{aligned}$$

Hence, pitch factor, $k_c = 0.966$.

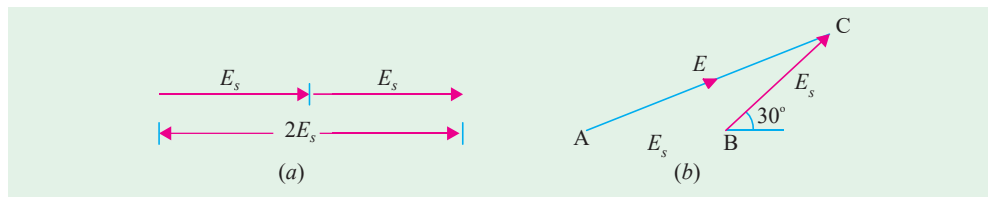

Fig. 37.17

In general, if the coil span falls short of full-pitch by an angle α (electrical)*,

then $k_c = \cos \alpha/2$.

Similarly, for a coil having a span of 2/3 pole-pitch, $k_c = \cos 60^\circ/2 = \cos 30^\circ = 0.866$.

It is lesser than the value in the first case.

Note. The value of α will usually be given in the question, if not, then assume $k_c = 1$.

* This angle is known as chording angle and the winding employing short-pitched coils is called chorded winding.

Example 37.1. Calculate the pitch factor for the under-given windings : (a) 36 stator slots, 4-poles, coil-span, 1 to 8 (b) 72 stator slots, 6 poles, coils span 1 to 10 and (c) 96 stator slots, 6 poles, coil span 1 to 12. Sketch the three coil spans.

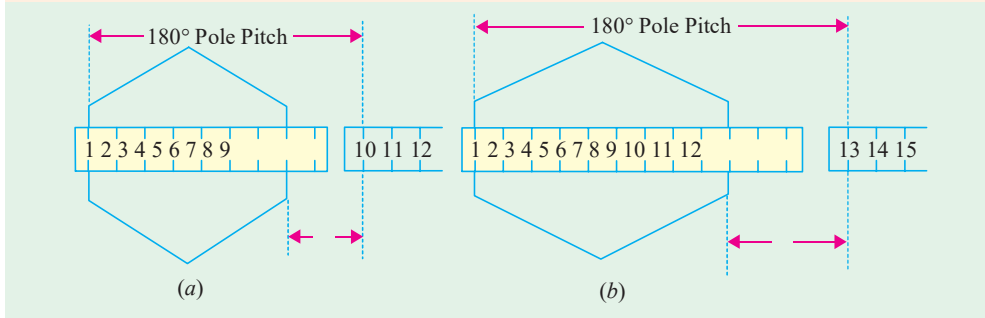

Fig. 37.18

Solution. (a) Here, the coil span falls short by $(2/9) \times 180^\circ = 40^\circ$

$$\alpha = 40^\circ$$

$$\therefore k_c = \cos 40^\circ/2 = \cos 20^\circ = \mathbf{0.94}$$

(b) Here $\alpha = (3/12) \times 180^\circ = 45^\circ \therefore k_c = \cos 45^\circ/2 = \cos 22.5^\circ = \mathbf{0.924}$

(c) Here $\alpha = (5/16) \times 180^\circ = 56^\circ 16' \therefore k_c = \cos 28^\circ 8' = \mathbf{0.882}$

The coil spans have been shown in Fig. 37.18.

Distribution or Breadth Factor or Winding Factor or Spread Factor

It will be seen that in each phase, coils are not concentrated or bunched in one slot, but are distributed in a number of slots to form polar groups under each pole. These coils/phase are displaced from each other by a certain angle. The result is that the e.m.fs. induced in coil sides constituting a polar group are not in phase with each other but differ by an angle equal to angular displacement of the slots.

In Fig. 37.19 are shown the end connections of a 3-phase single-layer winding for a 4-pole

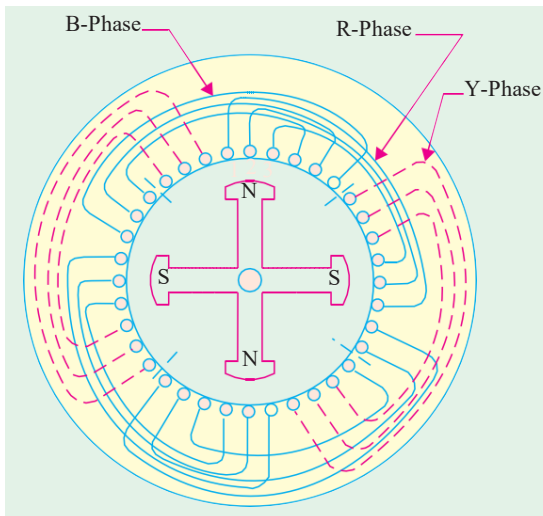

Fig. 37.19

alternator. It has a total of 36 slots *i.e.* 9 slots/pole. Obviously, there are 3 slots / phase / pole. For example, coils 1, 2 and 3 belong to R phase. Now, these three coils which constitute one polar group are not bunched in one slot but in three different slots. Angular displacement between any two adjacent slots = $180^\circ/9 = 20^\circ$ (elect.)

If the three coils were bunched in one slot, then total e.m.f. induced in the three sides of the coil would be the arithmetic sum of the three e.m.f.s. *i.e.* = $3 E_s$, where E_s is the e.m.f. induced in one coil side [Fig.37.20 (a)].

Since the coils are distributed, the individual e.m.fs. have a phase difference of 20° with each other. Their vector sum as seen from Fig. 35.20 (b) is

$$\begin{aligned}
 E &= E_S \cos 20^\circ + E_S + E_S \cos 20^\circ \\
 &= 2 E_S \cos 20^\circ + E_S \\
 &= 2 E_S \times 0.9397 + E_S = 2.88 E_S
 \end{aligned}$$

The distribution factor (k_d) is defined as

$$= \frac{\text{e.m.f. with distributed winding}}{\text{e.m.f. with concentrated winding}}$$

In the present case

$$k_d = \frac{\text{e.m.f. with winding in 3 slots/pole/phase}}{\text{e.m.f. with winding in 1 slots/pole/phase}} = \frac{E}{3 E_S} = \frac{2.88 E_S}{3 E_S} = 0.96$$

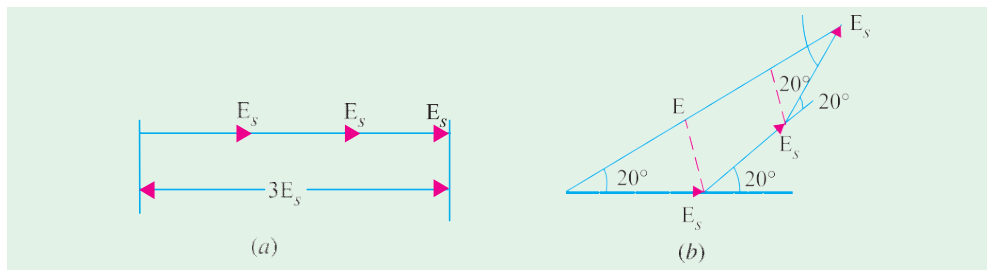

Fig. 37.20

General Case

Let β be the value of angular displacement between the slots. Its value is

$$\beta = \frac{180^\circ}{\text{No. of slots/pole}} = \frac{180^\circ}{n}$$

Let $m =$ No. of slots/phase/pole
 $m\beta =$ phase spread angle

Then, the resultant voltage induced in one polar group would be mE_S

where E_S is the voltage induced in one coil side. Fig. 37.21 illustrates the method for finding the vector sum of m voltages each of value E_S and having a mutual phase difference of β (if m is large, then the curve $ABCDE$ will become part of a circle of radius r).

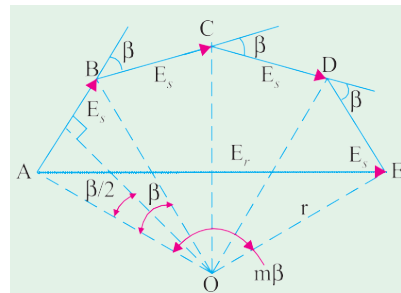

Fig. 37.21

$$AB = E_S = 2r \sin \beta/2$$

$$\text{Arithmetic sum is } = mE_S = m \times 2r \sin \beta/2$$

$$\text{Their vector sum} = AE = E_r = 2r \sin m\beta/2$$

$$\begin{aligned}
 k_d &= \frac{\text{vector sum of coils e.m.fs.}}{\text{arithmetic sum of coil e.m.fs.}} \\
 &= \frac{2r \sin m\beta / 2}{m \times 2r \sin \beta/2} = \frac{\sin m \beta / 2}{m \sin \beta / 2}
 \end{aligned}$$

The value of distribution factor of a 3-phase alternator for different number of slots/pole/phase is given in table No. 37.1.

Table 37.1

Slots per pole	m	β°	Distribution factor k_d
3	1	60	1.000
6	2	30	0.966
9	3	20	0.960
12	4	15	0.958
15	5	12	0.957
18	6	10	0.956
24	8	7.5	0.955

In general, when β is small, the above ratio approaches

$$= \frac{\text{chord}}{\text{arc}} = \frac{\sin m\beta / 2}{m \beta / 2} \quad \text{— angle } m\beta/2 \text{ in radians.}$$

Example 37.2. Calculate the distribution factor for a 36-slots, 4-pole, single-layer three-phase winding. (Elect. Machine-I Nagpur Univ. 1993)

Solution. $n = 36/4 = 9; \beta = 180^\circ/9 = 20^\circ; m = 36/4 \times 3 = 3$

$$k_d = \frac{\sin m\beta / 2}{m \sin \beta / 2} = \frac{\sin 3 \times 20^\circ / 2}{3 \sin 20^\circ / 2} = \mathbf{0.96}$$

Example 37.3. A part of an alternator winding consists of six coils in series, each coil having an e.m.f. of 10 V r.m.s. induced in it. The coils are placed in successive slots and between each slot and the next, there is an electrical phase displacement of 30° . Find graphically or by calculation, the e.m.f. of the six coils in series.

Solution. By calculation

Here $\beta = 30^\circ; m = 6 \therefore k = \frac{\sin m\beta / 2}{m \sin \beta / 2} = \frac{\sin 90^\circ}{6 \times \sin 15^\circ} = \frac{1}{6 \times 0.2588}$

Arithmetic sum of voltage induced in 6 coils = $6 \times 10 = 60$ V

Vector sum = $k_d \times \text{arithmetic sum} = 60 \times 1/6 \times 0.2588 = \mathbf{38.64V}$

Example 37.4. Find the value of k_d for an alternator with 9 slots per pole for the following cases :

(i) One winding in all the slots (ii) one winding using only the first 2/3 of the slots/pole (iii) three equal windings placed sequentially in 60° group.

Solution. Here, $\beta = 180^\circ/9 = 20^\circ$ and values of m i.e. number of slots in a group are 9, 6 and 3 respectively.

(i) $m = 9, \beta = 20^\circ, k_d = \frac{\sin 9 \times 20^\circ / 2}{9 \sin 20^\circ / 2} = \mathbf{0.64}$ [or $k_d = \frac{\sin \pi / 2}{\pi / 2} = 0.637$]

(ii) $m = 6, \beta = 20^\circ, k_d = \frac{\sin 6 \times 20^\circ / 2}{6 \sin 20^\circ / 2} = \mathbf{0.83}$ [or $k_d = \frac{\sin \pi / 3}{\pi / 3} = 0.827$]

(iii) $m = 3, \beta = 20^\circ, k_d = \frac{\sin 3 \times 20^\circ / 2}{3 \sin 20^\circ / 2} = \mathbf{0.96}$ [or $k_d = \frac{\sin \pi / 6}{\pi / 6} = 0.955$]

Equation of Induced E.M.F.

Let $Z =$ No. of conductors or coil sides in series/phase
 $= 2T$ — where T is the No. of coils or turns per phase
 (remember one turn or coil has two sides)

$P =$ No. of poles
 $f =$ frequency of induced e.m.f. in Hz
 $\Phi =$ flux/pole in webers

$$k_d = \text{distribution factor} = \frac{\sin m \beta / 2}{m \sin \beta / 2}$$

k_c or $k_p =$ pitch or coil span factor $= \cos \alpha / 2$
 $k_f =$ from factor $= 1.11$ —if e.m.f. is assumed sinusoidal
 $N =$ rotor r.p.m.

In one revolution of the rotor (*i.e.* in $60/N$ second) each stator conductor is cut by a flux of ΦP webers.

$$\therefore d\Phi = \Phi P \text{ and } dt = 60/N \text{ second}$$

$$\therefore \text{Average e.m.f. induced per conductor} = \frac{d\Phi}{dt} = \frac{\Phi P}{60/N} = \frac{\Phi NP}{60}$$

Now, we know that $f = PN/120$ or $N = 120f/P$

Substituting this value of N above, we get

$$\text{Average e.m.f. per conductor} = \frac{\Phi P}{60} \times \frac{120f}{P} = 2f\Phi \text{ volt}$$

If there are Z conductors in series/phase, then Average e.m.f./phase $= 2f\Phi Z \text{ volt} = 4f\Phi T \text{ volt}$
 R.M.S. value of e.m.f./phase $= 1.11 \times 4f\Phi T = 4.44f\Phi T \text{ volt}^*$.

This would have been the actual value of the induced voltage if all the coils in a phase were **(i)** full-pitched and **(ii)** concentrated or bunched in one slot (instead of being distributed in several slots under poles). But this not being so, the actually available voltage is reduced in the ratio of these two factors.

$$\therefore \text{Actually available voltage/phase} = 4.44 k_c k_d f \Phi T = 4 k_f k_c k_d f \Phi T \text{ volt.}$$

If the alternator is star-connected (as is usually the case) then the line voltage is $\sqrt{3}$ times the phase voltage (as found from the above formula).

Effect of Harmonics on Pitch and Distribution Factors

(a) If the short-pitch angle or chording angle is α degrees (electrical) for the fundamental flux wave, then its values for different harmonics are

for 3rd harmonic $= 3\alpha$; for 5th harmonic $= 5\alpha$ and so on.

$$\therefore \text{pitch-factor, } k_c = \cos \alpha / 2 \quad \text{—for fundamental}$$

$$= \cos 3\alpha / 2 \quad \text{—for 3rd harmonic}$$

$$= \cos 5\alpha / 2 \quad \text{—for 5th harmonic etc.}$$

(b) Similarly, the distribution factor is also different for different harmonics. Its value becomes

$$k_d = \frac{\sin m \beta / 2}{m \sin \beta / 2} \text{ where } n \text{ is the order of the harmonic}$$

* It is exactly the same equation as the e.m.f. equation of a transformer. (Art 32.6)

for fundamental,	$n = 1$	$k_{d1} = \frac{\sin m \beta / 2}{m \sin \beta / 2}$
for 3rd harmonic,	$n = 3$	$k_{d3} = \frac{\sin 3 m \beta / 2}{m \sin 3 \beta / 2}$
for 5th harmonic,	$n = 5$	$k_{d5} = \frac{\sin 5 m \beta / 2}{m \sin 5 \beta / 2}$

(c) Frequency is also changed. If fundamental frequency is 50 Hz i.e. $f_1 = 50$ Hz then other frequencies are:

3rd harmonic, $f_3 = 3 \times 50 = 150$ Hz, 5th harmonic, $f_5 = 5 \times 50 = 250$ Hz etc.

Example 37.5. An alternator has 18 slots/pole and the first coil lies in slots 1 and 16. Calculate the pitch factor for (i) fundamental (ii) 3rd harmonic (iii) 5th harmonic and (iv) 7th harmonic.

Solution. Here, coil span is $= (16 - 1) = 15$ slots, which falls short by 3 slots.

Hence, $\alpha = 180^\circ \times 3/18 = 30^\circ$

(i) $k_{c1} = \cos 30^\circ/2 = \cos 15^\circ = 0.966$ (ii) $k_{c3} = \cos 3 \times 30^\circ/2 = 0.707$

(iii) $k_{c5} = \cos 5 \times 30^\circ/2 = \cos 75^\circ = 0.259$ (iv) $k_{c7} = \cos 7 \times 30^\circ/2 = \cos 105^\circ = \cos 75^\circ = 0.259$.

Example 37.6. A 3-phase, 16-pole alternator has a star-connected winding with 144 slots and 10 conductors per slot. The flux per pole is 0.03 Wb, sinusoidally distributed and the speed is 375 r.p.m. Find the frequency rpm and the phase and line e.m.f. Assume full-pitched coil.

(Elect. Machines, AMIE Sec. B, 1991)

Solution. $f = PN/120 = 16 \times 375/120 = 50$ Hz

Since k_c is not given, it would be taken as unity.

$$n = 144/16 = 9; \beta = 180^\circ/9 = 20^\circ; m = 144/16 \times 3 = 3$$

$$k_d = \sin 3 \times (20^\circ/2)/3 \sin (20^\circ/2) = 0.96$$

$$Z = 144 \times 10 / 3 = 480; T = 480/2 = 240 / \text{phase}$$

$$E_{ph} = 4.44 \times 1 \times 0.96 \times 50 \times 0.03 \times 240 = 15.34 \text{ V}$$

Line voltage, $E_L = \sqrt{3} E_{ph} = \sqrt{3} \times 15.34 = 2658 \text{ V}$

Example 37.7. Find the no-load phase and line voltage of a star-connected 3-phase, 6-pole alternator which runs at 1200 rpm, having flux per pole of 0.1 Wb sinusoidally distributed. Its stator has 54 slots having double layer winding. Each coil has 8 turns and the coil is chorded by 1 slot.

(Elect. Machines-I, Nagput Univ. 1993)

Solution. Since winding is chorded by one slot, it is short-pitched by 1/9 or $180^\circ/9 = 20^\circ$

$$\therefore k_c = \cos 20^\circ/2 = 0.98; f = 6 \times 1200/120 = 60 \text{ Hz}$$

$$n = 54/6 = 9; \beta = 180^\circ/9 = 20^\circ, m = 54/6 \times 3 = 3$$

$$k_d = \sin 3 \times (20^\circ/2)/3 \sin (20^\circ/2) = 0.96$$

$$Z = 54 \times 8/3 = 144; T = 144/2 = 72, f = 6 \times 1200/120 = 60 \text{ Hz}$$

$$E_{ph} = 4.44 \times 0.98 \times 0.96 \times 60 \times 0.1 \times 72 = 1805 \text{ V}$$

Line voltage, $E_L = \sqrt{3} \times 1805 = 3125 \text{ V}$.

Example 37.8. The stator of a 3-phase, 16-pole alternator has 144 slots and there are 4 conductors per slot connected in two layers and the conductors of each phase are connected in series. If the speed of the alternator is 375 r.p.m., calculate the e.m.f. induced per phase. Resultant flux in the air-gap is 5×10^{-2} webers per pole sinusoidally distributed. Assume the coil span as 150° electrical.

(Elect. Machine, Nagpur Univ. 1993)

Solution. For sinusoidal flux distribution, $k_f = 1.11$; $\alpha = (180^\circ - 150^\circ) = 30^\circ$ (elect)

$$k_c = \cos 30^\circ/2 = 0.966^*$$

No. of slots / pole, $n = 144/16 = 9$;
 $\beta = 180^\circ/9 = 20^\circ$

$$m = \text{No. of slots/pole/phase} = 144/16 \times 3 = 3$$

$$\therefore k_d = \frac{\sin m \beta / 2}{m \sin \beta / 2} = \frac{\sin 3 \times 20^\circ / 2}{3 \sin 20^\circ / 2} = 0.96; f = 16 \times 375/120 = 50 \text{ Hz}$$

$$\text{No. of slots / phase} = 144/3 = 48; \text{No of conductors / slot} = 4$$

$$\therefore \text{No. of conductors in series/phase} = 48 \times 4 = 192$$

$$\therefore \text{turns / phase} = \text{conductors per phase}/2 = 192/2 = 96$$

$$E_{ph} = 4 k_f k_c k_d f \Phi T$$

$$= 4 \times 1.11 \times 0.966 \times 0.96 \times 50 \times 5 \times 10^{-2} \times 96 = \mathbf{988 \text{ V}}$$

Example 37.9. A 10-pole, 50-Hz, 600 r.p.m. alternator has flux density distribution given by the following expression

$$B = \sin \theta + 0.4 \sin 3 \theta + 0.2 \sin 5 \theta$$

The alternator has 180 slots wound with 2-layer 3-turn coils having a span of 15 slots. The coils are connected in 60° groups. If armature diameter is = 1.2 m and core length = 0.4 m, calculate

- (i) the expression for instantaneous e.m.f. / conductor
- (ii) the expression for instantaneous e.m.f./coil
- (iii) the r.m.s. phase and line voltages, if the machine is star-connected.

Solution. For finding voltage/conductor, we may either use the relation $B\ell v$ or use the relation of Art. 35-13.

$$\text{Area of pole pitch} = (1.2 \pi/10) \times 0.4 = 0.1508 \text{ m}^2$$

$$\text{Fundamental flux/pole, } \phi_1 = \text{av. flux density} \times \text{area} = 0.637 \times 1 \times 0.1508 = 0.096 \text{ Wb}$$

(a) RMS value of fundamental voltage per conductor,
 $= 1.1 \times 2 f \phi_1 = 1.1 \times 2 \times 50 \times 0.096 = \mathbf{10.56 \text{ V}}$

$$\text{Peak value} = \sqrt{2} \times 10.56 = 14.93 \text{ V}$$

Since harmonic conductor voltages are in proportion to their flux densities,

$$\text{3rd harmonic voltage} = 0.4 \times 14.93 = 5.97 \text{ V}$$

$$\text{5th harmonic voltage} = 0.2 \times 14.93 = 2.98 \text{ V}$$

Hence, equation of the instantaneous e.m.f./conductor is

$$\mathbf{e = 14.93 \sin \theta + 5.97 \sin 3 \theta + 2.98 \sin 5 \theta}$$

(b) Obviously, there are 6 conductors in a 3-turn coil. Using the values of k_c found in solved Ex. 37.5, we get

$$\text{fundamental coil voltage} = 6 \times 14.93 \times 0.966 = 86.5 \text{ V}$$

$$\text{3rd harmonic coil voltage} = 6 \times 5.97 \times 0.707 = 25.3 \text{ V}$$

$$\text{5th harmonic coil voltage} = 6 \times 2.98 \times 0.259 = 4.63 \text{ V}$$

* Since they are not of much interest, the relative phase angles of the voltages have not been included in the expression.

Hence, coil voltage expression is*

$$e = 86.5 \sin \theta + 25.3 \sin 3\theta + 4.63 \sin 5\theta$$

(c) Here, $m = 6, \beta = 180^\circ/18 = 10^\circ;$ $k_{d1} = \frac{\sin 6 \times 10^\circ / 2}{6 \sin 10^\circ / 2} = 0.956$

$$k_{d3} = \frac{\sin 3 \times 6 \times 10^\circ / 2}{6 \sin 3 \times 10^\circ / 2} = 0.644 \quad k_{d5} = \frac{\sin 5 \times 6 \times 10^\circ / 2}{6 \sin 5 \times 10^\circ / 2} = 0.197$$

It should be noted that number of coils per phase = $180/3 = 60$

$$\text{Fundamental phase e.m.f.} = (86.5 / \sqrt{2}) \times 60 \times 0.956 = 3510 \text{ V}$$

$$\text{3rd harmonic phase e.m.f.} = (25.3 / \sqrt{2}) \times 60 \times 0.644 = 691 \text{ V}$$

$$\text{5th harmonic phase e.m.f.} = (4.63 / \sqrt{2}) \times 60 \times 0.197 = 39 \text{ V}$$

$$\text{RMS value of phase voltage} = (3510^2 + 691^2 + 39^2)^{1/2} = 3577 \text{ V}$$

$$\text{RMS value of line voltage} = \sqrt{3} \times (3510^2 + 39^2)^{1/2} = 6080 \text{ V}$$

Example 37.10. A 4-pole, 3-phase, 50-Hz, star-connected alternator has 60 slots, with 4 conductors per slot. Coils are short-pitched by 3 slots. If the phase spread is 60° , find the line voltage induced for a flux per pole of 0.943 Wb distributed sinusoidally in space. All the turns per phase are in series. (Electrical Machinery, Mysore Univ. 1987)

Solution. As explained in Art. 37.12, phase spread = $m\beta = 60^\circ$ —given

Now, $m = 60/4 \times 3 = 5 \quad \therefore 5\beta = 60^\circ, \beta = 12^\circ$

$$k_d = \frac{\sin 5 \times 12^\circ / 2}{5 \sin 12^\circ / 2} = 0.957; \alpha = (3/15) \times 180^\circ = 36^\circ; k_c = \cos 18^\circ = 0.95$$

$$Z = 60 \times 4/3 = 80; T = 80/2 = 40; \Phi = 0.943 \text{ Wb}; k_f = 1.11$$

$$\therefore E_{ph} = 4 \times 1.11 \times 0.95 \times 0.975 \times 50 \times 0.943 \times 40 = 7613 \text{ V}$$

$$E_L = \sqrt{3} \times 7613 = 13,185 \text{ V}$$

Example 37.11. A 4-pole, 50-Hz, star-connected alternator has 15 slots per pole and each slot has 10 conductors. All the conductors of each phase are connected in series' the winding factor being 0.95. When running on no-load for a certain flux per pole, the terminal e.m.f. was 1825 volt. If the windings are lap-connected as in a d.c. machine, what would be the e.m.f. between the brushes for the same speed and the same flux/pole. Assume sinusoidal distribution of flux.

Solution. Here $k_f = 1.11, k_d = 0.95, k_c = 1$ (assumed)
 $f = 50 \text{ Hz}; \text{e.m.f./phase} = 1825 / \sqrt{3} \text{ V}$

Total No. of slots = $15 \times 4 = 60$

\therefore No. of slots/phase = $60/3 = 20$; No. of turns/phase = $20 \times 10/2 = 100$

$\therefore \frac{1825 / \sqrt{3}}{4 \times 1.11 \times 1 \times 0.95 \times \Phi \times 50 \times 100} \therefore \Phi = 49.97 \text{ mWb}$

When connected as a d.c. generator

$$E_g = (\Phi Z N / 60) \times (P/A) \text{ volt}$$

$$Z = 60 \times 10 = 600, \quad N = 120 f / P = 120 \times 50 / 4 = 1500 \text{ r.p.m.}$$

$$\therefore E_g = \frac{49.97 \times 10^{-3} \times 600 \times 1500}{60} \times \frac{4}{4} = 750 \text{ V}$$

* Also $k_d = \sin 150^\circ/2 = \sin 75^\circ = 0.966$

Example 37.12. An alternator on open-circuit generates 360 V at 60 Hz when the field current is 3.6 A. Neglecting saturation, determine the open-circuit e.m.f. when the frequency is 40 Hz and the field current is 2.4 A.

Solution. As seen from the e.m.f. equation of an alternator,

$$E \propto \Phi f \quad \therefore \frac{E_1}{E_2} = \frac{\Phi_1 f_1}{\Phi_2 f_2}$$

Since saturation is neglected, $\Phi \propto I_f$ where I_f is the field current

$$\therefore \frac{E_1}{E_2} = \frac{I_{f1} \cdot f_1}{I_{f2} \cdot f_2} \quad \text{or} \quad \frac{360}{E_2} = \frac{3.6 \times 60}{2.4 \times 40}; \quad E_2 = 160 \text{ V}$$

Example 37.13. Calculate the R.M.S. value of the induced e.m.f. per phase of a 10-pole, 3-phase, 50-Hz alternator with 2 slots per pole per phase and 4 conductors per slot in two layers. The coil span is 150° . The flux per pole has a fundamental component of 0.12 Wb and a 20% third component. (Elect. Machines-III, Punjab Univ. 1991)

Solution. Fundamental E.M.F.

$$\alpha = (180^\circ - 150^\circ) = 30^\circ; \quad k_{c1} = \cos \alpha/2 = \cos 15^\circ = 0.966$$

$$m = 2; \quad \text{No. of slots/pole} = 6; \quad \beta = 180^\circ/6 = 30^\circ$$

$$\therefore k_{d1} = \frac{\sin m \beta / 2}{m \sin \beta / 2} = \frac{\sin 2 \times 30^\circ / 2}{2 \sin 30^\circ / 2} = 0.966$$

$$Z = 10 \times 2 \times 4 = 80; \quad \text{turn/phase, } T = 80/2 = 40$$

$$\therefore \text{Fundamental E.M.F./phase} = 4.44 k_c k_d f \Phi T$$

$$\therefore E_1 = 4.44 \times 0.966 \times 0.966 \times 50 \times 0.12 \times 40 = 995 \text{ V}$$

Harmonic E.M.F.

$$K_{c3} = \cos 3 \alpha/2 = \cos 3 \times 30^\circ/2 = \cos 45^\circ = 0.707$$

$$k_{d3} = \frac{\sin mn \beta / 2}{m \sin n \beta / 2} \quad \text{where } n \text{ is the order of the harmonic i.e. } n = 3$$

$$\therefore k_{d3} = \frac{\sin 2 \times 3 \times 30^\circ / 2}{2 \sin 3 \times 30^\circ / 2} = \frac{\sin 90^\circ}{2 \sin 45^\circ} = 0.707, \quad f_3 = 50 \times 3 = 150 \text{ Hz}$$

$$\Phi_3 = (1/3) \times 20\% \text{ of fundamental flux} = (1/3) \times 0.02 \times 0.12 = 0.008 \text{ Wb}$$

$$\therefore E_3 = 4.44 \times 0.707 \times 0.707 \times 150 \times 0.008 \times 40 = 106 \text{ V}$$

$$\therefore E \text{ per phase} = \sqrt{E_1^2 + E_3^2} = \sqrt{995^2 + 106^2} = 1000 \text{ V}$$

Note. Since phase e.m.fs. induced by the 3rd, 9th and 15th harmonics etc. are eliminated from the line voltages, the line voltage for a Y-connection would be $= 995 \times \sqrt{3}$ volt.

Example 37.14. A 3-phase alternator has generated e.m.f. per phase of 230 V with 10 per cent third harmonic and 6 per cent fifth harmonic content. Calculate the r.m.s. line voltage for (a) star connection (b) delta-connection. Find also the circulating current in delta connection if the reactance per phase of the machine at 50-Hz is 10Ω . (Elect. Machines-III, Osmania Univ. 1988)

Solution. It should be noted that in both star and delta-connections, the third harmonic components of the three phases cancel out at the line terminals because they are co-phased. Hence, the line e.m.f. is composed of the fundamental and the fifth harmonic only.

(a) Star-connection

$$E_1 = 230 \text{ V}; \quad E_5 = 0.06 \times 230 = 13.8 \text{ V}$$

$$\text{E.M.F./phase} = \sqrt{E_1^2 + E_5^2} = \sqrt{230^2 + 13.8^2} = 230.2 \text{ V}$$

$$\text{R.M.S. value of line e.m.f.} = \sqrt{3} \times 230.2 = \mathbf{3.99 \text{ V}}$$

(b) Delta-connection

Since for delta-connection, line e.m.f. is the same as the phase e.m.f.

$$\text{R.M.S. value of line e.m.f.} = \mathbf{230.2 \text{ V}}$$

In delta-connection, third harmonic components are additive round the mesh, hence a circulating current is set up whose magnitude depends on the reactance per phase at the third harmonic frequency.

$$\text{R.M.S. value of third harmonic e.m.f. per phase} = 0.1 \times 230 = 23 \text{ V}$$

$$\text{Reactance at triple frequency} = 10 \times 3 = 30 \Omega$$

$$\text{Circulating current} = 23/30 = \mathbf{0.77 \text{ A}}$$

Example 37.15 (a). A motor generator set used for providing variable frequency a.c. supply consists of a three-phase, 10-pole synchronous motor and a 24-pole, three-phase synchronous generator. The motor-generator set is fed from a 25 Hz, three-phase a.c. supply. A 6-pole, three-phase induction motor is electrically connected to the terminals of the synchronous generator and runs at a slip of 5%. Determine :

(i) the frequency of the generated voltage of the synchronous generator.

(ii) the speed at which the induction motor is running. (U.P. Technical University 2001)

Solution. Speed of synchronous motor = $(120 \times 25)/10 = 300 \text{ rpm}$.

(i) At 300 rpm, frequency of the voltage generated by 24-pole synchronous generator

$$= \frac{24 \times 300}{120} = 60 \text{ Hz}$$

Synchronous speed of the 6-pole induction motor fed from a 60 Hz supply

$$= \frac{120 \times 60}{6} = 1200 \text{ rpm}$$

(ii) With 5% slip, the speed of this induction motor = $0.95 \times 1200 = 1140 \text{ rpm}$.

Further, the frequency of the rotor-currents = $s f = 0.05 \times 60 = 3 \text{ Hz}$.

Example 37.15 (b). Find the no load line voltage of a star connected 4-pole alternator from the following :

Flux per pole = 0.12 Weber, Slots per pole per phase = 4

Conductors/slot = 4, Two layer winding, with coil span = 150°

[Bharthithasan University, April 1997]

Solution. Total number of slots = $4 \times 3 \times 4 = 48$, Slot pitch = 15° electrical

Total number of conductors = $48 \times 4 = 192$, Total number of turns = 96

No. of turns in series per phase = 32

For a 60° phase spread,

$$k_b = \frac{\sin(60^\circ/2)}{4 \times \sin 7.5^\circ} = 0.958$$

For 150° coil-span, pitch factor $k_p = \cos 15^\circ = 0.966$, and for 50 Hz frequency,

$$E_{ph} = 4.44 \times 50 \times 0.12 \times 0.958 \times 0.966 \times 32 = 789 \text{ volts}$$

$$E_{line} = 789 \times 1.732 = 1366.6 \text{ volts}$$

Tutorial Problems 37.1

1. Find the no-load phase and line voltage of a star-connected, 4-pole alternator having flux per pole of 0.1 Wb sinusoidally distributed; 4 slots per pole per phase, 4 conductors per slot, double-layer winding with a coil span of 150° .
 [Assuming $f = 50$ Hz; 789 V; 1366 V] (*Elect. Technology-I, Bombay Univ. 1978*)
2. A 3- ϕ , 10-pole, Y-connected alternator runs at 600 r.p.m. It has 120 stator slots with 8 conductors per slot and the conductors of each phase are connected in series. Determine the phase and line e.m.fs. if the flux per pole is 56 mWb. Assume full-pitch coils.
 [1910 V; 3300 V] (*Electrical Technology-II, Madras Univ. April 1977*)
3. Calculate the speed and open-circuit line and phase voltages of a 4-pole, 3-phase, 50-Hz, star-connected alternator with 36 slots and 30 conductors per slot. The flux per pole is 0.0496 Wb and is sinusoidally distributed.
 [1500 r.p.m.; 3,300 V; 1,905 V] (*Elect. Engg-II, Bombay Univ. 1979*)
4. A 4-pole, 3-phase, star-connected alternator armature has 12 slots with 24 conductors per slot and the flux per pole is 0.1 Wb sinusoidally distributed.
 Calculate the line e.m.f. generated at 50 Hz. [1850 V]
5. A 3-phase, 16-pole alternator has a star-connected winding with 144 slots and 10 conductors per slot. The flux per pole is 30 mWb sinusoidally distributed. Find the frequency, the phase and line voltage if the speed is 375 rpm. [50 Hz; 1530 V; 2650 V] (*Electrical Machines-I, Indore Univ. April 1977*)
6. A synchronous generator has 9 slots per pole. If each coil spans 8 slot pitches, what is the value of the pitch factor? [0.985] (*Elect. Machines, A.M.I.E. Sec. B. 1989*)
7. A 3-phase, Y-connected, 2-pole alternator runs at 3,600 r.p.m. If there are 500 conductors per phase in series on the armature winding and the sinusoidal flux per pole is 0.1 Wb, calculate the magnitude and frequency of the generated voltage from first principles. [60 Hz; 11.5 kV]
8. One phase of a 3-phase alternator consists of twelve coils in series. Each coil has an r.m.s. voltage of 10 V induced in it and the coils are arranged in slots so that there is a successive phase displacement of 10 electrical degrees between the e.m.f. in each coil and the next. Find graphically or by calculation, the r.m.s. value of the total phase voltage developed by the winding. If the alternator has six pole and is driven at 100 r.p.m., calculate the frequency of the e.m.f. generated. [108 V; 50 Hz]
9. A 4-pole, 50-Hz, 3-phase, Y-connected alternator has a single-layer, full-pitch winding with 21 slots per pole and two conductors per slot. The fundamental flux is 0.6 Wb and air-gap flux contains a third harmonic of 5% amplitude. Find the r.m.s. values of the phase e.m.f. due to the fundamental and the 3rd harmonic flux and the total induced e.m.f.
 [3,550 V; 119.5 V; 3,553 V] (*Elect. Machines-III, Osmania Univ. 1977*)
10. A 3-phase, 10-pole alternator has 90 slots, each containing 12 conductors. If the speed is 600 r.p.m. and the flux per pole is 0.1 Wb, calculate the line e.m.f. when the phases are (i) star connected (ii) delta connected. Assume the winding factor to be 0.96 and the flux sinusoidally distributed.
 [(i) 6.93 kV (ii) 4 kV] (*Elect. Engg-II, Kerala Univ. 1979*)
11. A star-connected 3-phase, 6-pole synchronous generator has a stator with 90 slots and 8 conductors per slot. The rotor revolves at 1000 r.p.m. The flux per pole is 4×10^{-2} weber. Calculate the e.m.f. generated, if all the conductors in each phase are in series. Assume sinusoidal flux distribution and full-pitched coils.
 [E_{ph} = 1,066 V] (*Elect. Machines, A.M.I.E. Summer, 1979*)
12. A six-pole machine has an armature of 90 slots and 8 conductors per slot and revolves at 1000 r.p.m. the flux per pole being 50 milli weber. Calculate the e.m.f. generated as a three-phase star-connected machine if the winding factor is 0.96 and all the conductors in each phase are in series.
 [1280 V] (*Elect. Machines, AMIE, Sec. B, (E-3), Summer 1992*)
13. A 3-phase, 16 pole alternator has a star connected winding with 144 slots and 10 conductors per slot. The flux/pole is 0.04 wb (sinusoidal) and the speed is 375 rpm. Find the frequency and phase and line e.m.f. The total turns/phase may be assumed to series connected.
 [50 Hz, 2035 Hz, 3525 V] (*Rajiv Gandhi Technical University, Bhopal, 2000*)

Factors Affecting Alternator Size

The efficiency of an alternator always increases as its power increases. For example, if an alternator of 1 kW has an efficiency of 50%, then one of 10 MW will inevitably have an efficiency of about 90%. It is because of this improvement in efficiency with size that alternators of 1000 MW and above possess efficiencies of the order of 99%.

Another advantage of large machines is that power output per kilogram increases as the alternator power increases. If 1 kW alternator weighs 20 kg (*i.e.* 50 W/kg), then 10MW alternator weighing 20,000 kg yields 500 W/kg. In other words, larger alternators weigh relatively less than smaller ones and are, consequently, cheaper.

However, as alternator size increases, cooling problem becomes more serious.

Since large machines inherently produce high power loss per unit surface area (W/m^2), they tend to overheat.



Light weight alternator



Large weight alternator

To keep the temperature rise within acceptable limits, we have to design efficient cooling system which becomes ever more elaborate as the power increases. For cooling alternators of rating upto 50 MW, circulating cold-air system is adequate but for those of rating between 50 and 300 MW, we have to resort to hydrogen cooling. Very big machines in 1000 MW range have to be equipped with hollow water-cooled conductors. Ultimately, a point is reached where increased cost of cooling exceeds the saving made elsewhere and this fixes the upper limit of the alternator size.

So far as the speed is concerned, low-speed alternators are always bigger than high speed alternators of the same power. Bigness always simplifies the cooling problem. For example, the large 200-rpm, 500-MVA alternators installed in a typical

hydropower plant are air-cooled whereas much smaller 1800-r.p.m., 500-MVA alternators installed in a steam plant are hydrogen cooled.

Alternator on Load

As the load on an alternator is varied, its terminal voltage is also found to vary as in d.c. generators. This variation in terminal voltage V is due to the following reasons:

1. voltage drop due to armature resistance R_a
2. voltage drop due to armature leakage reactance X_L
3. voltage drop due to armature reaction

(a) Armature Resistance

The armature resistance/phase R_a causes a voltage drop/phase of IR_a which is in phase with the armature current I . However, this voltage drop is practically negligible.

(b) Armature Leakage Reactance

When current flows through the armature conductors, fluxes are set up which do not cross the air-gap, but take different paths. Such fluxes are known as *leakage fluxes*. Various types of leakage fluxes are shown in Fig. 37.22.

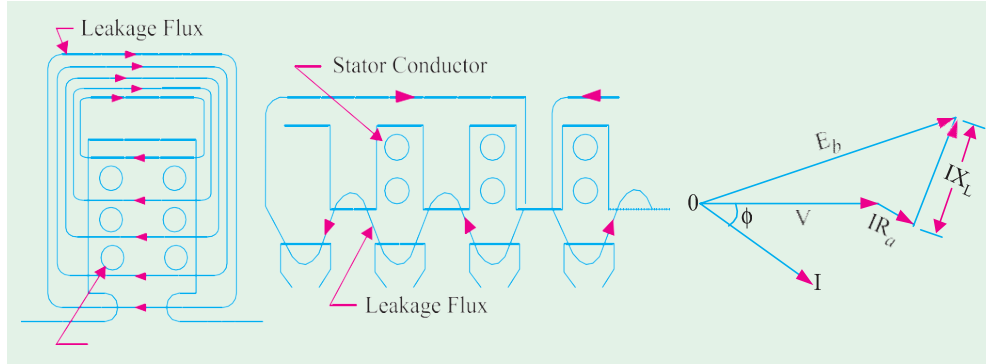

Fig. 37.22

Fig. 37.23

The leakage flux is practically independent of saturation, but is dependent on I and its phase angle with terminal voltage V . This leakage flux sets up an e.m.f. of self-inductance which is known as *reactance e.m.f.* and which is ahead of I by 90° . Hence, armature winding is assumed to possess leakage reactance X_L (also known as Potier reactance X_P) such that voltage drop due to this equals IX_L . A part of the generated e.m.f. is used up in overcoming this reactance e.m.f.

\therefore

$$E = V + I(R + jX_L)$$

This fact is illustrated in the vector diagram of Fig. 37.23.

(c) Armature Reaction

As in d.c. generators, armature reaction is the effect of armature flux on the main field flux. **In the case of alternators, the power factor of the load has a considerable effect on the armature reaction.** We will consider three cases : (i) when load of p.f. is unity (ii) when p.f. is zero lagging and (iii) when p.f. is zero leading.

Before discussing this, it should be noted that in a 3-phase machine the combined ampere-turn wave (or m.m.f. wave) is sinusoidal which moves synchronously. This amp-turn or m.m.f. wave is fixed relative to the poles, its amplitude is proportional to the load current, but its position depends on the p.f. of the load.

Consider a 3-phase, 2-pole alternator having a single-layer winding, as shown in Fig. 37.24 (a). For the sake of simplicity, assume that winding of each phase is concentrated (instead of being distributed) and that the number of turns per phase is N . Further suppose that the alternator is loaded with a resistive load of unity power factor, so that phase currents I_a , I_b and I_c are in phase with their respective phase voltages. Maximum current I_a will flow when the poles are in position shown in Fig. 37.24 (a) or at a time t_1 in Fig. 37.24 (c). When I_a has a maximum value, I_b and I_c have one-half their maximum values (the arrows attached to I_a , I_b and I_c are only polarity marks and are not meant to give the instantaneous directions of these currents at time t_1). The instantaneous directions of currents are shown in Fig. 37.24 (a). At the instant t_1 , I_a flows in conductor α whereas I_b and I_c flow out.

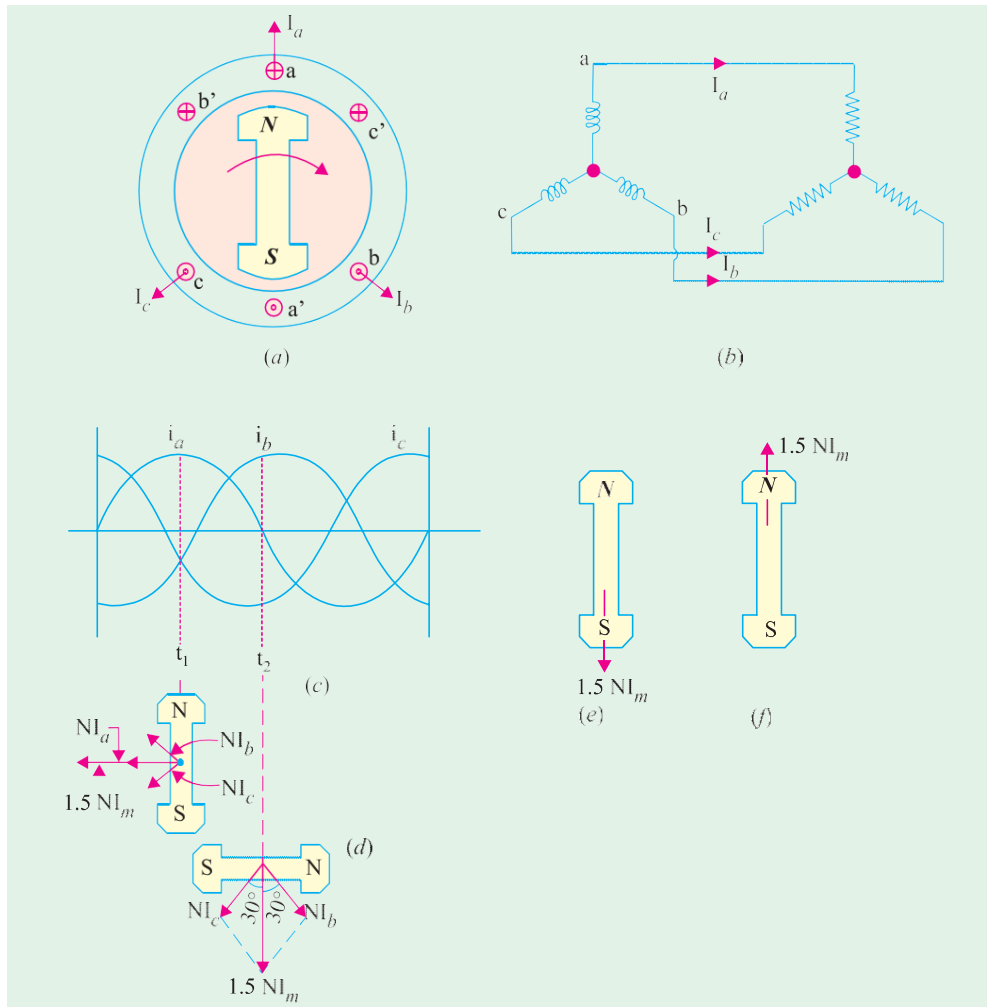

Fig. 37.24

As seen from Fig. 37.24 (d), the m.m.f. ($= NI_m$) produced by phase *a*-als horizontal, whereas that produced by other two phases is $(I_m/2) N$ each at 60° to the horizontal. The total armature m.m.f. is equal to the vector sum of these three m.m.fs.

$$\therefore \text{Armature m.m.f.} = NI_m + 2 \cdot (1/2 NI_m) \cos 60^\circ = 1.5 NI_m$$

As seen, at this instant t_1 , the m.m.f. of the main field is upwards and the armature m.m.f. is behind it by 90° electrical degrees.

Next, let us investigate the armature m.m.f. at instant t_2 . At this instant, the poles are in the horizontal position. Also $I_a = 0$, but I_b and I_c are each equal to 0.866 of their maximum values. Since I_c has not changed in direction during the interval t_1 to t_2 , the direction of its m.m.f. vector remains unchanged. But I_b has changed direction, hence, its m.m.f. vector will now be in the position shown in Fig. 37.24 (d). Total armature m.m.f. is again the vector sum of these two m.m.fs.

$$\therefore \text{Armature m.m.f.} = 2 \times (0.866 NI_m) \times \cos 30^\circ = 1.5 NI_m$$

If further investigations are made, it will be found that.

1. armature m.m.f. remains constant with time

2. it is 90 space degrees behind the main field m.m.f., so that it is only distortional in nature.
3. it rotates synchronously round the armature *i.e.* stator.

For a lagging load of zero power factor, all currents would be delayed in time 90° and armature m.m.f. would be shifted 90° with respect to the poles as shown in Fig. 37.24 (e). Obviously, armature m.m.f. would demagnetise the poles and cause a reduction in the induced e.m.f. and hence the terminal voltage.

For leading loads of zero power factor, the armature m.m.f. is advanced 90° with respect to the position shown in Fig. 37.24 (d). As shown in Fig. 37.24 (f), the armature m.m.f. strengthens the main m.m.f. In this case, armature reaction is wholly magnetising and causes an increase in the terminal voltage.

The above facts have been summarized briefly in the following paragraphs where the matter is discussed in terms of 'flux' rather than m.m.f. waves.

1. Unity Power Factor

In this case [Fig. 37.25 (a)] the armature flux is cross-magnetising. The result is that the flux at the leading tips of the poles is reduced while it is increased at the trailing tips. However, these two effects nearly offset each other leaving the average field strength constant. In other words, armature reaction for unity p.f. is distortional.

2. Zero P.F. lagging

As seen from Fig. 37.25 (b), here the armature flux (whose wave has moved backward by 90°) is in direct opposition to the main flux.

Hence, the main flux is decreased. Therefore, it is found that armature reaction, in this case, is wholly **demagnetising**, with the result, that due to weakening of the main flux, less e.m.f. is generated. To keep the value of generated e.m.f. the same, field excitation will have to be increased to compensate for this weakening.

3. Zero P.F. leading

In this case, shown in Fig. 37.25 (c) armature flux wave has moved forward by 90° so that it is in phase with the main flux wave. This results in added main flux. Hence, in this case, armature reaction is wholly **magnetising**, which results in greater induced e.m.f. To keep the value of generated e.m.f. the same, field excitation will have to be reduced somewhat.

4. For intermediate power factor [Fig. 37.25 (d)], the effect is partly distortional and partly demagnetising (because p.f. is lagging).

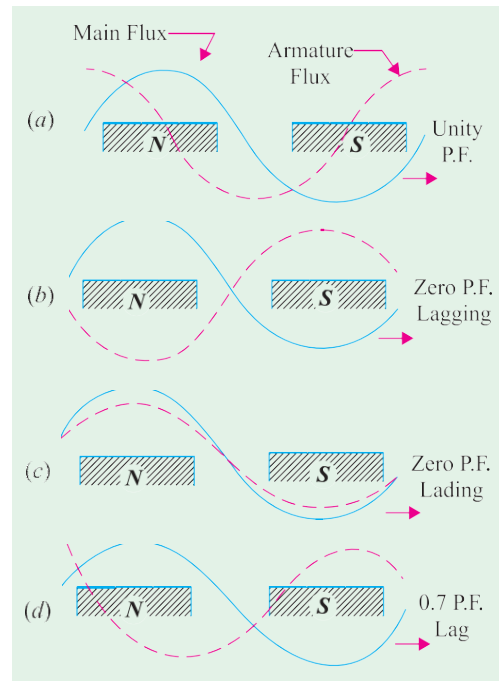

Fig. 37.25

Synchronous Reactance

From the above discussion, it is clear that for the same field excitation, terminal voltage is decreased from its no-load value E_0 to V (for a lagging power factor). This is because of

1. drop due to armature resistance, IR_a
2. drop due to leakage reactance, IX_L
3. drop due to armature reaction.

The drop in voltage due to armature reaction may be accounted for by assuming the presence of a fictitious reactance X_a in the armature winding. The value of X_a is such that IX_a represents the voltage drop due to armature reaction.

The leakage reactance X_L (or X_p) and the armature reactance X_a may be combined to give synchronous reactance X_S .

Hence $X_S = X_L + X_a^*$

Therefore, total voltage drop in an alternator under load is $= IR_a + jIX_S = I(R_a + jX_S) = IZ_S$ where Z_S is known as synchronous impedance of the armature, the word ‘synchronous’ being used merely as an indication that it refers to the working conditions.

Hence, we learn that the vector difference between no-load voltage E_0 and terminal voltage V is equal to IZ_S , as shown in Fig. 37.26.

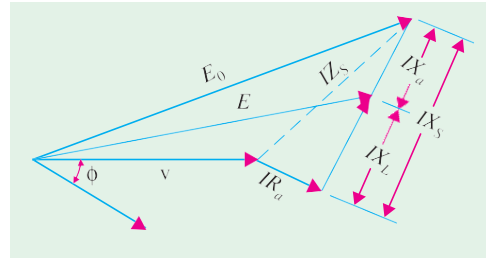

Fig. 37.26

Vector Diagrams of a Loaded Alternator

Before discussing the diagrams, following symbols should be clearly kept in mind.

E_0 = No-load e.m.f. This being the voltage induced in armature in the absence of three factors discussed in Art. 37.16. Hence, it represents the maximum value of the induced e.m.f.

E = Load induced e.m.f. It is the induced e.m.f. after allowing for armature reaction. E is vectorially less than E_0 by IX_a . Sometimes, it is written as E_a (Ex. 37.16).

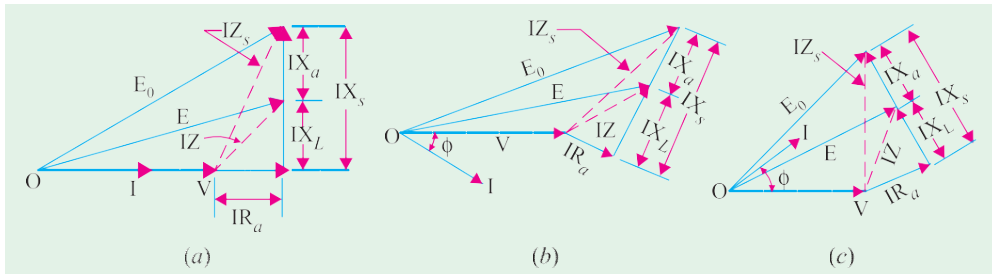

Fig. 37.27

V = Terminal voltage, It is vectorially less than E_0 by IZ_S or it is vectorially less than E by $I Z$ where

$$Z = \sqrt{(R_a^2 + X_L^2)} . \text{ It may also be written as } Z_a.$$

I = armature current/phase and ϕ = load p.f. angle.

In Fig. 37.27 (a) is shown the case for unity p.f., in Fig. 37.27 (b) for lagging p.f. and in Fig. 37.27 (c) for leading p.f. All these diagrams apply to one phase of a 3-phase machine. Diagrams for the other phases can also be drawn similarly.

Example 37.16. A 3-phase, star-connected alternator supplies a load of 10 MW at p.f. 0.85 lagging and at 11 kV (terminal voltage). Its resistance is 0.1 ohm per phase and synchronous reactance 0.66 ohm per phase. Calculate the line value of e.m.f. generated.

(Electrical Technology, Aligarh Muslim Univ. 1988)

* The ohmic value of X_a varies with the p.f. of the load because armature reaction depends on load p.f.

Solution. F.L. output current = $\frac{10 \times 10^6}{\sqrt{3} \times 11,000 \times 0.85} = 618 \text{ A}$

$IR_a \text{ drop} = 618 \times 0.1 = 61.8 \text{ V}$

$IX_s \text{ drop} = 618 \times 0.66 = 408 \text{ V}$

Terminal voltage/phase = $11,000\sqrt{3} = 6,350 \text{ V}$

$\phi = \cos^{-1}(0.85) = 31.8^\circ; \sin \phi = 0.527$

As seen from the vector diagram of Fig. 37.28 where I instead of V has been taken along reference vector,

$$E_0 = \sqrt{(V \cos \phi + IR_a)^2 + (V \sin \phi + IX_s)^2}$$

$$= \sqrt{(6350 \times 0.85 + 61.8)^2 + (6350 \times 0.527 + 408)^2}$$

$$= 6,625 \text{ V}$$

Line e.m.f. = $\sqrt{3} \times 6,625 = 11,486 \text{ volt}$

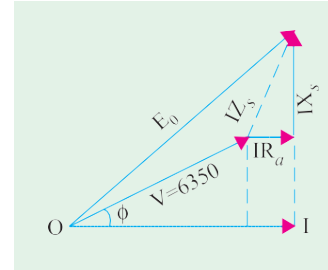

Fig. 37.28

Voltage Regulation

It is clear that with change in load, there is a change in terminal voltage of an alternator. The magnitude of this change depends **not only on the load but also on the load power factor.**

The voltage regulation of an alternator is defined as “the rise in voltage when full-load is removed (field excitation and speed remaining the same) divided by the rated terminal voltage.”

$$\therefore \% \text{ regulation 'up'} = \frac{E_0 - V}{V} \times 100$$

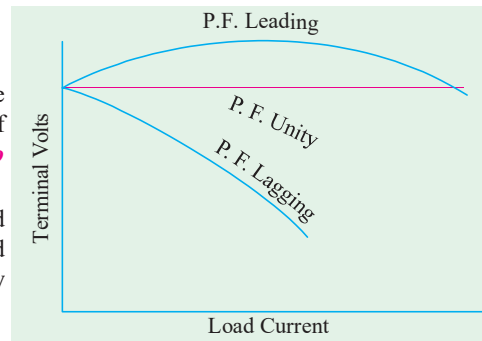

Fig. 37.29

Note. (i) $E_0 - V$ is the arithmetical difference and not the vectorial one.

(ii) In the case of *leading* load p.f., terminal voltage will fall on removing the full-load. Hence, regulation is negative in that case.

(iii) The rise in voltage when full-load is thrown off is not the same as the fall in voltage when full-load is applied.

Voltage characteristics of an alternator are shown in Fig. 37.29.

Determination of Voltage Regulation

In the case of small machines, the regulation may be found by direct loading. The procedure is as follows :

The alternator is driven at synchronous speed and the terminal voltage is adjusted to its rated value V . The load is varied until the wattmeter and ammeter (connected for the purpose) indicate the rated values at desired p.f. Then the entire load is thrown off while the speed and field excitation are kept constant. The open-circuit or no-load voltage E_0 is read. Hence, regulation can be found from

$$\% \text{ regn} = \frac{E_0 - V}{V} \times 100$$

In the case of large machines, the cost of finding the regulation by direct loading becomes prohibitive. Hence, other indirect methods are used as discussed below. It will be found that all these methods differ chiefly in the way the no-load voltage E_0 is found in each case.

1. **Synchronous Impedance or E.M.F. Method.** It is due to Behn Eschenberg.
2. **The Ampere-turn or M.M.F. Method.** This method is due to Rother.
3. **Zero Power Factor or Potier Method.** As the name indicates, it is due to Potier.

All these methods require—

1. Armature (or stator) resistance R_a
2. Open-circuit/No-load characteristic.
3. Short-circuit characteristic (but zero power factor lagging characteristic for Potier method).

Now, let us take up each of these methods one by one.

(i) Value of R_a

Armature resistance R_a per phase can be measured directly by voltmeter and ammeter method or by using Wheatstone bridge. However, under working conditions, the effective value of R_a is increased due to 'skin effect'*. The value of R_a so obtained is increased by 60% or so to allow for this effect. Generally, a value 1.6 times the d.c. value is taken.

(ii) O.C. Characteristic

As in d.c. machines, this is plotted by running the machine on no-load and by noting the values of induced voltage and field excitation current. It is just like the $B-H$ curve.

(iii) S.C. Characteristic

It is obtained by short-circuiting the armature (*i.e.* stator) windings through a low-resistance ammeter. The excitation is so adjusted as to give 1.5 to 2 times the value of full-load current. During this test, the speed which is not necessarily synchronous, is kept constant.

Example 37.17 (a). *The effective resistance of a 2200V, 50Hz, 440 KVA, 1-phase, alternator is 0.5 ohm. On short circuit, a field current of 40 A gives the full load current of 200 A. The electromotive force on open-circuits with same field excitation is 1160 V. Calculate the synchronous impedance and reactance.* (Madras University, 1997)

Solution. For the 1-ph alternator, since the field current is same for O.C. and S.C. conditions

$$Z_s = \frac{1160}{200} = 5.8 \text{ ohms}$$

$$X_s = \sqrt{5.8^2 - 0.5^2} = 5.7784 \text{ ohms}$$

Example 37.17 (b). *A 60-KVA, 220 V, 50-Hz, 1- ϕ alternator has effective armature resistance of 0.016 ohm and an armature leakage reactance of 0.07 ohm. Compute the voltage induced in the armature when the alternator is delivering rated current at a load power factor of (a) unity (b) 0.7 lagging and (c) 0.7 leading.* (Elect. Machines-I, Indore Univ. 1981)

Solution. Full load rated current $I = 60,000/220 = 272.2 \text{ A}$

$$IR_a = 272.2 \times 0.016 = 4.3 \text{ V ;}$$

$$IX_L = 272.2 \times 0.07 = 19 \text{ V}$$

(a) **Unity p.f.** — Fig. 37.30 (a)

$$E = \sqrt{(V + IR_a)^2 + (IX_L)^2} = \sqrt{(220 + 4.3)^2 + 19^2} = 225 \text{ V}$$

* The 'skin effect' may sometimes increase the effective resistance of armature conductors as high as 6 times its d.c. value.

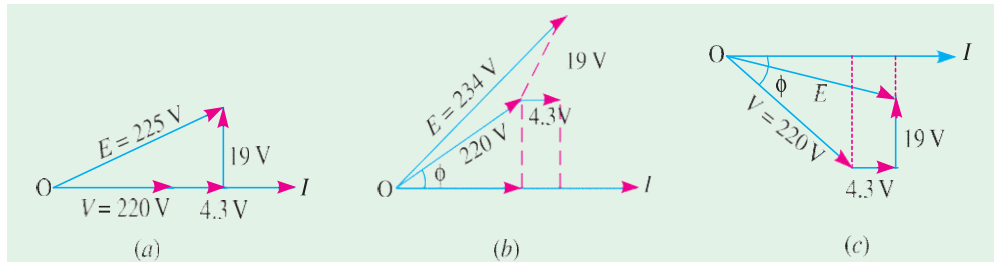

Fig. 37.30

(b) p.f. 0.7 (lag) —Fig. 37.30 (b)

$$E = [V \cos \phi + IR_a]^2 + (V \sin \phi + IX_L)^2]^{1/2}$$

$$= [(220 \times 0.7 + 4.3)^2 + (220 \times 0.7 + 19)^2]^{1/2} = 234 \text{ V}$$

(c) p.f. = 0.7 (lead) —Fig. 37.30 (c)

$$E = [(V \cos \phi + IR_a)^2 + (V \sin \phi - IX_L)^2]^{1/2}$$

$$= [(220 \times 0.7 + 4.3)^2 + (220 \times 0.7 - 19)^2]^{1/2} = 208 \text{ V}$$

Example 37.18 (a). In a 50-kVA, star-connected, 440-V, 3-phase, 50-Hz alternator, the effective armature resistance is 0.25 ohm per phase. The synchronous reactance is 3.2 ohm per phase and leakage reactance is 0.5 ohm per phase. Determine at rated load and unity power factor :

(a) Internal e.m.f. E_a (b) no-load e.m.f. E_0 (c) percentage regulation on full-load (d) value of synchronous reactance which replaces armature reaction.

(Electrical Engg. Bombay Univ. 1987)

Solution. (a) The e.m.f. E_a is the vector sum of (i) terminal voltage V (ii) IR_a and (iii) IX_L as detailed in Art. 37.17. Here,

$$V = 440 / \sqrt{3} = 254 \text{ V}$$

F.L. output current at u.p.f. is

$$= 50,000 / \sqrt{3} \times 440 = 65.6 \text{ A}$$

Resistive drop = $65.6 \times 0.25 = 16.4 \text{ V}$

Leakage reactance drop $IX_L = 65.6 \times 0.5 = 32.8 \text{ V}$

$$\therefore E_a = \sqrt{(V + IR_a)^2 + (IX_L)^2}$$

$$= \sqrt{(254 + 16.4)^2 + 32.8^2} = 272 \text{ volt}$$

Line value = $\sqrt{3} \times 272 = 471 \text{ volt.}$

(b) The no-load e.m.f. E_0 is the vector sum of (i) V (ii) IR_a and (iii) IX_S or is the vector sum of V and IZ_S (Fig. 37.31).

$$\therefore E_0 = \sqrt{(V + IR_a)^2 + (IX_S)^2} = \sqrt{(254 + 16.4)^2 + (65.6 \times 3.2)^2} = 342 \text{ volt}$$

Line value = $\sqrt{3} \times 342 = 592 \text{ volt}$

$$(c) \text{ \%age regulation 'up'} = \frac{E_0 - V}{V} \times 100 = \frac{342 - 254}{254} \times 100 = 34.65 \text{ per cent}$$

$$(d) X_a = X_S - X_L = 3.2 - 0.5 = 2.7 \Omega \quad \dots \text{Art. 37.17}$$

Example 37.18 (b). A 1000 kVA, 3300-V, 3-phase, star-connected alternator delivers full-load current at rated voltage at 0.80 p.f. Lagging. The resistance and synchronous reactance of the

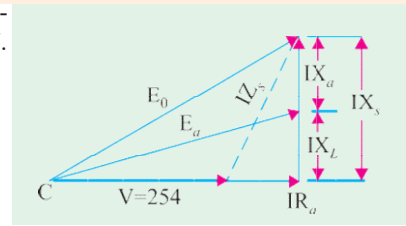

Fig. 37.31

machine per phase are 0.5 ohm and 5 ohms respectively. Estimate the terminal voltage for the same excitation and same load current at 0.80 p.f. leading. (Amravati University, 1999)

Solution. $V_{ph} = \frac{3300}{\sqrt{3}} = 1905$ volts

At rated load, $I_{ph} = \frac{1000 \times 1000}{\sqrt{3} \times 3300} = 175$ amp

From phasor diagram for this case [Fig. 37.32 (a)]

Component of E along Ref = $OD = OA + AB \cos \phi + BC \sin \phi$
 $= 1905 + (87.5 \times 0.80) + (875 \times 0.60) = 2500$

Component of E along perpendicular direction
 $= CD = -AB \sin \phi + BC \cos \phi$
 $= 87.5 \times 0.6 + 875 \times 0.80 = 647.5$ volts

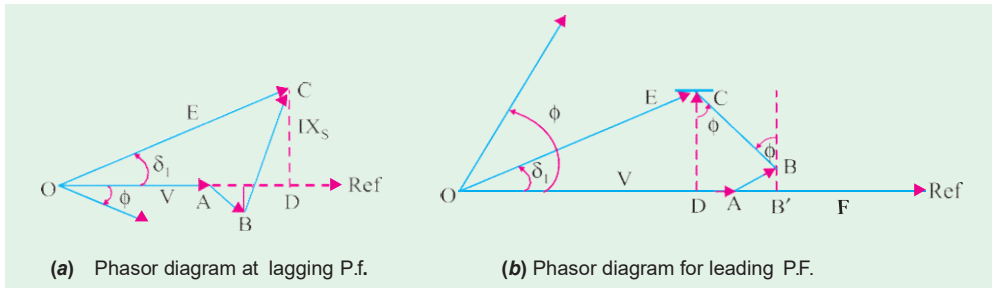

Fig. 37.32

$$OA = 1950, AB = I_r = 87.5, BC = IX_s = 875$$

$$OC = E = \sqrt{OD^2 + DC^2} = \sqrt{2500^2 + 647.5^2} = 2582.5 \text{ volts}$$

$$\delta_1 = \sin^{-1} \frac{CD}{OC} = \sin^{-1} (647.5 / 2582.5) = 14.52^\circ$$

Now, for E kept constant, and the alternator delivering rated current at 0.80 leading p.f., the phasor diagram is to be drawn to evaluate V.

Construction of the phasor diagram starts with marking the reference. Take a point A which is the terminating point of phasor V which starts from O. O is the point yet to be marked, for which the other phasors have to be drawn.

$$AB = 87.5, BC = 875$$

$$BAF = 36.8^\circ$$

BC perpendicular to AB. From C, draw an arc of length E, i.e. 2582.5 volts to locate O.

Note. Construction of Phasor diagram starts from known AE, V is to be found.

Along the direction of the current, $AB = 87.5$, $\angle BAF = 36.8^\circ$, since the current is leading. $BC = 875$ which must be perpendicular to AB. Having located C, draw a line CD which is perpendicular to the reference, with point D, on it, as shown.

Either proceed graphically drawing to scale or calculate geometrically :

$$CD = AB \sin \phi + BC \cos \phi = (87.5 \times 0.60) + (875 \times 0.80) = 752.5 \text{ volts}$$

Since $CD = E \sin \delta_2$, $\sin \delta_2 = 752.5/2582.5$ giving $\delta_2 = 17^\circ$

$$OD = E \cos \delta = 2470 \text{ volts}$$

$$DA = DB' AB'$$

$$= BC \sin \phi - AB \cos \phi - 875 \times 0.6 - 87.5 \times 0.8 = 455 \text{ volts}$$

Terminal voltage, $V = OA = OD + DA = 2470 + 455 = 2925$ volts/phase

Since the alternator is star connected, line voltage $\sqrt{3} \times 2925 = 5066$ volts

Check : While delivering lagging p.f. current,

Total power delivered = $(100 \text{ kVA}) \times 0.80 = 800 \text{ kW}$

In terms of E and δ_1 referring to the impedance-triangle in Fig. 37.32 (c)

$$\begin{aligned} \text{total power delivered} &= 3 \left[\frac{VE}{Z_S} \cos(\theta - \delta_1) - \frac{V^2}{Z_S} \cos \theta \right] \\ &= 3 \left[\frac{1905 \times 2582.5}{5.025} \cos(84.3^\circ - 14.52^\circ) - \frac{1905^2}{5.025} \times \cos 84.3^\circ \right] \\ &\quad \square \quad 5.025 \quad \square \\ &= 800 \text{ kW} \quad \dots \text{checked} \\ OA &= 0.5, \quad AB = 5 \\ OB &= \sqrt{0.5^2 + 5^2} = 5.025 \Omega \\ \theta &= \angle BOA = \tan^{-1}(X/R) = \tan^{-1} 10 = 84.3^\circ \end{aligned}$$

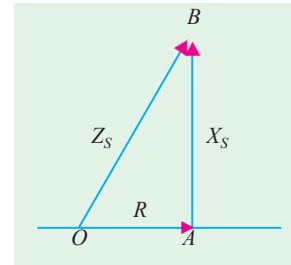

Fig. 37.32 (c) Impedance triangle for the Alternator

While delivering leading p.f. current the terminal voltage is 5.066 kV line to line.

Total power delivered in terms of V and I

$$= \sqrt{3} \times 5.066 \times 175 \times 0.8 \text{ kW} = 1228.4 \text{ kW}$$

In terms of E and with voltages expressed in volts,

$$\begin{aligned} \text{total power output} &= 3 \left[\frac{VE}{Z_S} \cos(\theta - \delta) - \frac{V^2}{Z_S} \cos \theta \right] \times 10^{-3} \text{ kW} \\ &= 3 \left[\frac{2925 \times 2582.5}{5.025} \cos(84.3^\circ - 17^\circ) - \frac{2925^2}{5.025} \times \cos 84.3^\circ \right] \times 10^{-3} \text{ kW} \\ &= 3 \left[\frac{2925 \times 2582.5}{5.025} \times \cos(67.3^\circ) - \frac{2925 \times 2925}{5.025} \cos 84.3^\circ \right] \text{ kW} \\ &\quad \square \quad 5.025 \quad \square \\ &= 3(580.11 - 169.10) = 1233 \text{ kW, which agrees fairly closely to the previous figure} \\ &\text{and hence checks our answer.} \end{aligned}$$

Synchronous Impedance Method

Following procedural steps are involved in this method:

1. O.C.C is plotted from the given data as shown in Fig. 37.33 (a).
2. Similarly, S.C.C. is drawn from the data given by the short-circuit test. It is a straight line passing through the origin. Both these curves are drawn on a common field-current base.

Consider a field current I_f . The O.C. voltage corresponding to this field current is E_1 . When winding is short-circuited, the terminal voltage is zero. Hence, it may be assumed that the whole of this voltage E_1 is being used to circulate the armature short-circuit current I_1 against the synchronous impedance Z_S .

$$\therefore \quad E_1 = I_1 Z_S \quad \therefore Z_S = \frac{E_1 (\text{open-circuit})}{I_1 (\text{short-circuit})}$$

3. Since R_a can be found as discussed earlier, $X_S = \sqrt{(Z_S^2 - R_a^2)}$

4 Knowing R_a and X_s , vector diagram as shown in Fig. 37.33 (b) can be drawn for any load and any power factor.

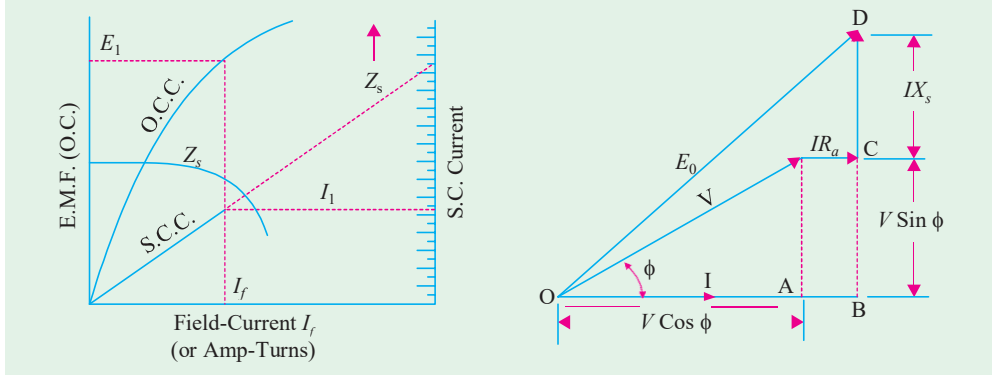

Fig. 37.33 (a)

Fig. 37.33 (b)

Here $OD = E_0 \therefore E_0 = \sqrt{(OB^2 + BD^2)}$
 or $E_0 = \sqrt{[(V \cos \phi + IR_a)^2 + (V \sin \phi + IX_s)^2]}$
 \therefore % regn. 'up' = $\frac{E_0 - V}{V} \times 100$

Note. (i) Value of regulation for unity power factor or leading p.f. can also be found in a similar way.

(ii) This method is not accurate because the value of Z_s so found is always more than its value under normal voltage conditions and saturation. Hence, the value of regulation so obtained is always more than that found from an actual test. That is why it is called pessimistic method. The value of Z_s is not constant but varies with saturation. At low saturation, its value is larger because then the effect of a given armature ampere-turns is much more than at high saturation. Now, under short-circuit conditions, saturation is very low, because armature m.m.f. is directly demagnetising. Different values of Z_s corresponding to different values of field current are also plotted in Fig. 37.33 (a).

(iii) The value of Z_s usually taken is that obtained from full-load current in the short-circuit test.

(iv) Here, armature reactance X_a has not been treated separately but along with leakage reactance X_L .

Example 37.19. Find the synchronous impedance and reactance of an alternator in which a given field current produces an armature current of 200 A on short-circuit and a generated e.m.f. of 50 V on open-circuit. The armature resistance is 0.1 ohm. To what induced voltage must the alternator be excited if it is to deliver a load of 100 A at a p.f. of 0.8 lagging, with a terminal voltage of 200V. **(Elect. Machinery, Bangalore Univ. 1991)**

Solution. It will be assumed that alternator is a single phase one. Now, for same field current,

$$Z_s = \frac{\text{O.C. volts}}{\text{S.C. current}} = \frac{50}{200} = 0.25 \Omega.$$

$$X_s = \sqrt{Z_s^2 - R_a^2} = \sqrt{0.25^2 - 0.1^2} = 0.23 \Omega.$$

Now, $IR_a = 100 \times 0.1 = 10 \text{ V}$, $IX_s = 100 \times 0.23 = 23 \text{ V}$;
 $\cos \phi = 0.8$, $\sin \phi = 0.6$. As seen from Fig. 37.34.

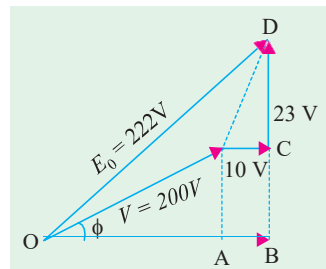

Fig. 37.34

$$E_0 = \sqrt{(V \cos \phi + IR_a)^2 + (V \sin \phi + IX_s)^2}$$

$$= [(200 \times 0.8 + 10)^2 + (200 \times 0.6 + 23)^2]^{1/2} = 222 \text{ V}$$

Example 37.20. From the following test results, determine the voltage regulation of a 2000-V, 1-phase alternator delivering a current of 100 A at (i) unity p.f. (ii) 0.8 leading p.f. and (iii) 0.71 lagging p.f.

Test results : Full-load current of 100 A is produced on short-circuit by a field excitation of 2.5A. An e.m.f. of 500 V is produced on open-circuit by the same excitation. The armature resistance is 0.8Ω .
(Elect. Engg.-II, M.S. Univ. 1987)

Solution.

$$Z_s = \frac{\text{O.C. volts}}{\text{S.C. current}} \quad \text{---for same excitation}$$

for same excitation

$$= 500/100 = 5 \Omega$$

$$X_s = \sqrt{Z_s^2 - R_a^2} = \sqrt{5^2 - 0.8^2} = 4.936 \Omega$$

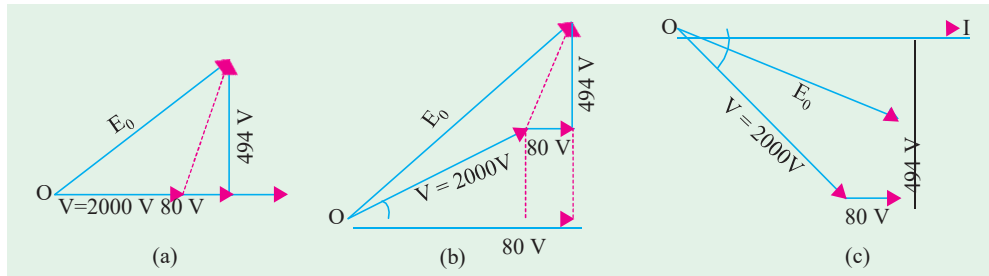

Fig. 37.35

(i) **Unity p.f.** (Fig. 37.35(a))

$$IR_a = 100 \times 0.8 = 80 \text{ V}; IX_s = 100 \times 4.936 = 494 \text{ V}$$

$$\therefore E_0 = \sqrt{(2000 + 80)^2 + 494^2} = 2140 \text{ V}$$

$$\% \text{ regn} = \frac{2140 - 2000}{2000} \times 100 = 7\%$$

(ii) **p.f. = 0.8 (lead)** [Fig. 37.35 (c)]

$$E_0 = [(2000 \times 0.8 + 80)^2 + (2000 \times 0.6 - 494)^2]^{1/2} = 1820 \text{ V}$$

$$\% \text{ regn} = \frac{1820 - 2000}{2000} \times 100 = -9\%$$

(iii) **p.f. = 0.71(lag)** [Fig.37.35 (b)]

$$E_0 = [(2000 \times 0.71 + 80)^2 + (2000 \times 0.71 + 494)^2]^{1/2} = 2432 \text{ V}$$

$$\% \text{ regn} = \frac{2432 - 2000}{2000} \times 100 = 21.6\%$$

Example 37.21. A 100-kVA, 3000-V, 50-Hz 3-phase star-connected alternator has effective armature resistance of 0.2 ohm. The field current of 40 A produces short-circuit current of 200 A and an open-circuit emf of 1040 V (line value). Calculate the full-load voltage regulation at 0.8 p.f. lagging and 0.8 p.f. leading. Draw phasor diagrams.

(Basic Elect. Machines, Nagpur Univ. 1993)

Solution.

$$Z_s = \frac{\text{O.C. voltage/phase}}{\text{S.C. current/phase}} \quad \text{— for same excitation}$$

$$= \frac{1040\sqrt{3}}{200} = 3 \Omega$$

$$X_s = \sqrt{Z_s^2 - R_a^2} = \sqrt{3^2 - 0.2^2}$$

$$= 2.99 \Omega$$

F.L. current,

$$I = 100,000 / \sqrt{3} \times 3000$$

$$= 19.2 \text{ A}$$

$$IR_a = 19.2 \times 0.2 = 3.84 \text{ V}$$

$$IX_s = 19.2 \times 2.99 = 57.4 \text{ V}$$

Voltage/phase

$$= 3000 / \sqrt{3} = 1730 \text{ V}$$

$$\cos \phi = 0.8 ; \sin \phi = 0.6$$

(i) **p.f. = 0.8 lagging**

—Fig. 37.36 (a)

$$E_0 = [(V \cos \phi + IR_a)^2 + (V \sin \phi + IX_s)^2]^{1/2}$$

$$= [(1730 \times 0.8 + 3.84)^2 + (1730 \times 0.6 + 57.4)^2]^{1/2} = 1768 \text{ V}$$

$$\% \text{ regn. 'up'} = \frac{(1768 - 1730)}{1730} \times 100 = \mathbf{2.2\%}$$

(ii) **0.8 p.f. leading**—Fig. 37.36 (b)

$$E_0 = [(V \cos \phi + IR_a)^2 + (V \sin \phi - IX_s)^2]^{1/2}$$

$$= [(1730 \times 0.8 + 3.84)^2 + (1730 \times 0.6 - 57.4)^2]^{1/2}$$

$$= 1699 \text{ V}$$

$$\% \text{ regn.} = \frac{1699 - 1730}{1730} \times 100 = \mathbf{-1.8\%}$$

Example 37.22. A 3-phase, star-connected alternator is rated at 1600 kVA, 13,500 V. The armature resistance and synchronous reactance are 1.5 Ω and 30 Ω respectively per phase. Calculate the percentage regulation for a load of 1280 kW at 0.8 leading power factor.

(Advanced Elect. Machines AMIE Sec. B, 1991)

Solution.

$$1280,000 = \sqrt{3} \times 13,500 \times I \times 0.8;$$

$$\therefore I = 68.4 \text{ A}$$

$$IR_a = 68.4 \times 1.5 = 103 \text{ V} ; IX_s = 68.4 \times 30 = 2052$$

$$\text{Voltage/phase} = 13,500 / \sqrt{3} = 7795 \text{ V}$$

As seen from Fig. 37.37.

$$E_0 = [(7795 \times 0.8 + 103)^2 + (7795 \times 0.6 - 2052)^2]^{1/2} = 6663 \text{ V}$$

$$\% \text{ regn.} = (6663 - 7795) / 7795$$

$$= -0.1411 \text{ or } \mathbf{-14.11\%}$$

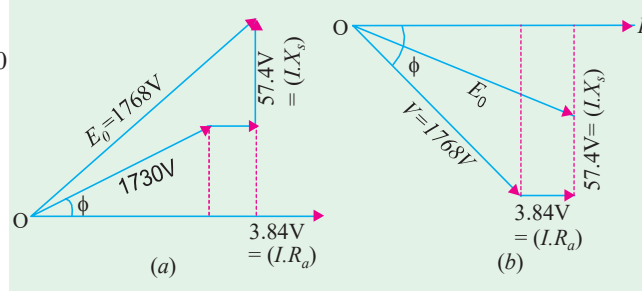

Fig. 37.36

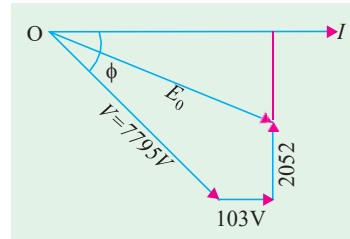

Fig. 37.37

Example 37.23. A 3-phase, 10-kVA, 400-V, 50-Hz, Y-connected alternator supplies the rated load at 0.8 p.f. lag. If arm. resistance is 0.5 ohm and syn. reactance is 10 ohms, find the power angle and voltage regulation. (Elect. Machines-I Nagpur Univ. 1993)

Solution. F.L. current, $I = 10,000 / \sqrt{3} \times 400 = 14.4 \text{ A}$

$$IR_a = 14.4 \times 0.5 = 7.2 \text{ V}$$

$$IX_s = 14.4 \times 10 = 144 \text{ V}$$

$$\text{Voltage/phase} = 400 / \sqrt{3} = 231 \text{ V}$$

$$\phi = \cos^{-1} 0.8 = 36.87^\circ, \text{ as shown in Fig. 37.38.}$$

$$E_0 = [(V \cos \phi + IR_a)^2 + (V \sin \phi + IX_s)^2]^{1/2}$$

$$= (231 \times 0.8 + 7.2)^2 + (231 \times 0.6 + 144)^2]^{1/2}$$

$$= 342 \text{ V}$$

$$\% \text{ regn.} = \frac{342 - 231}{231} \times 100 = 0.48 \text{ or } 48\%$$

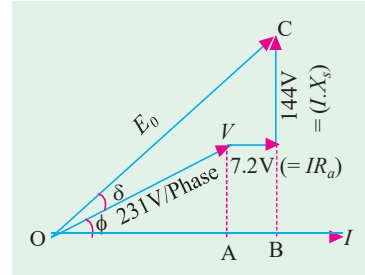

Fig. 37.38

The power angle of the machine is defined as the angle between V and E_0 i.e. angle δ

$$\text{As seen from Fig. 37.38, } \tan(\phi + \delta) = \frac{BC}{OB} = \frac{231 \times 0.6 + 144}{231 \times 0.8 + 7.2} = \frac{282.6}{192} = 1.4419;$$

$$\therefore (\phi + \delta) = 55.26^\circ$$

$$\therefore \text{power angle } \delta = 55.26^\circ - 36.87^\circ = 18.39^\circ$$

Example 37.24. The following test results are obtained from a 3-phase, 6,000-kVA, 6,600 V, star-connected, 2-pole, 50-Hz turbo-alternator:

With a field current of 125 A, the open-circuit voltage is 8,000 V at the rated speed; with the same field current and rated speed, the short-circuit current is 800 A. At the rated full-load, the resistance drop is 3 per cent. Find the regulation of the alternator on full-load and at a power factor of 0.8 lagging. (Electrical Technology, Utkal Univ. 1987)

$$\text{Solution. } Z_s = \frac{\text{O.C. voltage/phase}}{\text{S.C. current/phase}} = \frac{8000 / \sqrt{3}}{800} = 5.77 \Omega$$

$$\text{Voltage/phase} = 6,600 / \sqrt{3} = 3,810 \text{ V}$$

$$\text{Resistive drop} = 3\% \text{ of } 3,810 \text{ V} = 0.03 \times 3,810 = 114.3 \text{ V}$$

$$\text{Full-load current} = 6,000 \times 10^3 / \sqrt{3} \times 6,600 = 525 \text{ A}$$

$$\text{Now } IR_a = 114.3 \text{ V}$$

$$\therefore R_a = 114.3 / 525 = 0.218 \Omega$$

$$X_s = \sqrt{Z_s^2 - R_a^2} = \sqrt{5.77^2 - 0.218^2} = 5.74 \Omega \text{ (approx.)}$$

As seen from the vector diagram of Fig. 37.33, (b)

$$E_0 = \sqrt{[3,810 \times 0.8 + 114.3]^2 + (3,810 \times 0.6 + 525 \times 5.74)^2} = 6,180 \text{ V}$$

$$\therefore \text{regulation} = (6,180 - 3,810) \times 100 / 3,810 = 62.2\%$$

Example 37.25. A 3-phase 50-Hz star-connected 2000-kVA, 2300 V alternator gives a short-circuit current of 600 A for a certain field excitation. With the same excitation, the open circuit voltage was 900 V. The resistance between a pair of terminals was 0.12 Ω . Find full-load regulation at (i) UPF (ii) 0.8 p.f. lagging. (Elect. Machines, Nagpur Univ. 1993)

$$\text{Solution. } Z_s = \frac{\text{O.C. volts/phase}}{\text{S.C. current/phase}} = \frac{900 / \sqrt{3}}{600} = 0.866 \Omega$$

Resistance between the terminals is 0.12Ω . It is the resistance of two phases connected in series.

\therefore Resistance/phase = $0.12/2 = 0.06 \Omega$;
 effective resistance/phase = $0.06 \times 1.5 = 0.09 \Omega$;

$$X_S = \sqrt{0.866^2 - 0.09^2} = 0.86 \Omega$$

F.L. $I = 2000,000 / \sqrt{3} \times 2300 = 500 \text{ A}$

$IR_a = 500 \times 0.06 = 30 \text{ V}$;

$IX_S = 500 \times 0.86 = 430 \text{ V}$

rated voltage/phase

$= 2300 / \sqrt{3} = 1328 \text{ V}$

(i) **U.P.F.** — Fig. 37.39 (a),
 $E_0 = [(V \cos \phi + IR_a)^2 + (IX_S)^2]^{1/2}$

$= \sqrt{(1328 + 30)^2 + 430^2} = 1425 \text{ V}$

% regn. = $(1425 - 1328)/1328 = 0.073$ or **7.3%**

(ii) **0.8 p.f. lagging** — Fig. 37.39 (b)

$$E_0 = [(V \cos \phi + IR_a)^2 + (V \sin \phi + IX_S)^2]^{1/2}$$

$$= [(1328 \times 0.8 + 30)^2 + (1328 \times 0.6 + 430)^2]^{1/2} = 1643 \text{ V}$$

\therefore % regn. = $(1643 - 1328)/1328 = 0.237$ or **23.7%**.

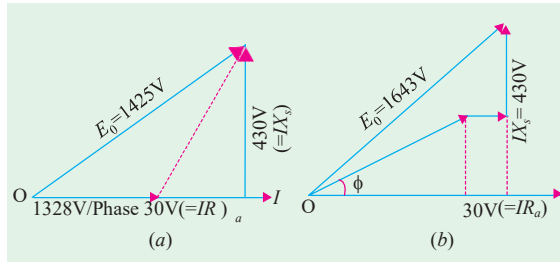

Fig. 37.39

Example 37.26. A 2000-kVA, 11-kV, 3-phase, star-connected alternator has a resistance of 0.3 ohm and reactance of 5 ohm per phase. It delivers full-load current at 0.8 lagging power factor at rated voltage. Compute the terminal voltage for the same excitation and load current at 0.8 power factor leading. **(Elect. Machines, Nagpur Univ. 1993)**

Solution. (i) At 0.8 p.f. lagging

F.L. $I = 2000,000 / \sqrt{3} \times 11,000 = 105 \text{ A}$

Terminal voltage = $11,000 / \sqrt{3} = 6350 \text{ V}$

$IR_a = 105 \times 0.3 = 31.5 \text{ V}$;

$IX_S = 105 \times 5 = 525 \text{ V}$

As seen from Fig. 37.40(a)
 $E_0 = [6350 \times 0.8 + 31.5]^2 + (6350 \times 0.6 + 525)^2]^{1/2} = 6700 \text{ V}$

As seen from Fig. 37.40 (b), now, we are given $E_0 = 6700 \text{ V}$ and we are required to find the terminal voltage V at 0.8 p.f. leading.

$6700^2 = (0.8V + 31.5)^2 + (0.6V - 525)^2$; $V = 6975 \text{ V}$

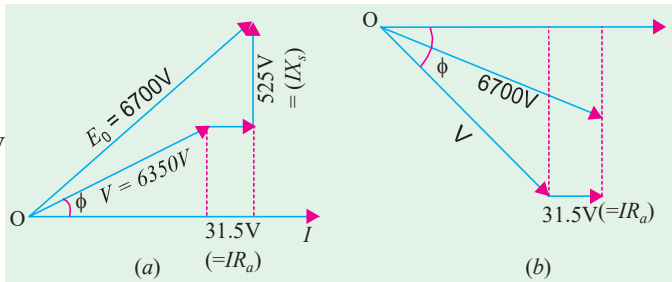

Fig. 37.40

Example 37.27. The effective resistance of a 1200-kVA, 3.3-kV, 50-Hz, 3-phase, Y-connected alternator is 0.25Ω /phase. A field current of 35 A produces a current of 200 A on short-circuit and 1.1 kV (line to line) on open circuit. Calculate the power angle and p.u. change in magnitude of the terminal voltage when the full load of 1200 kVA at 0.8 p.f. (lag) is thrown off. Draw the corresponding phasor diagram. **(Elect. Machines, A.M.I.E. Sec. B, 1993)**

Solution. $Z_s = \frac{\text{O.C. voltage}}{\text{S.C. voltage}}$

$$= \frac{1.1 \times 10^3 / \sqrt{3}}{200} = 3.175 \Omega$$

$$X_s = \sqrt{3.175^2 - 0.25^2} = 3.165 \Omega$$

$$V = 3.3 \times 10^3 / 3 \sqrt{3} = 1905 \text{ V}$$

$$\tan \theta = X_s / R_a = 3.165 / 0.25, \theta = 85.48^\circ$$

$$\therefore Z_s = 3.175 \angle 85.48^\circ$$

$$\text{Rated } I_a = 1200 \times 10^3 / \sqrt{3} \times 3.3 \times 10^3 = 210 \text{ A}$$

$$\text{Let, } V = 1905 \angle 0^\circ, I_a = 210 \angle -36.87^\circ$$

As seen from Fig. 37.41,

$$E = V + I_a Z_s = 1905 + 210 \angle -36.87^\circ \times 3.175 \angle 85.48^\circ = 2400 \angle 12^\circ$$

$$\text{Power angle } = \delta = 12^\circ$$

Per unit change in terminal voltage is

$$= (2400 - 1905) / 1905 = 0.26$$

—same excitation

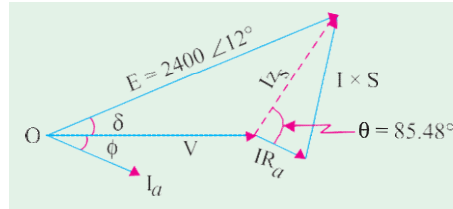

Fig. 37.41

Example 37.28. A given 3-MVA, 50-Hz, 11-kV, 3- ϕ , Y-connected alternator when supplying 100 A at zero p.f. leading has a line-to-line voltage of 12,370 V; when the load is removed, the terminal voltage falls down to 11,000 V. Predict the regulation of the alternator when supplying full-load at 0.8 p.f. lag. Assume an effective resistance of 0.4 Ω per phase.

(Elect. Machines, Nagpur Univ. 1993)

Solution. As seen from Fig. 37.42 (a), at zero p.f. leading

$$E_0^2 = (V \cos \phi + IR_a)^2 + (V \sin \phi - IX_s)^2$$

$$\text{Now, } E_0 = 11,000 / \sqrt{3} = 6350 \text{ V}$$

$$V = 12370 / 3 \sqrt{3} = 7,142 \text{ V,}$$

$$\cos \phi = 0, \sin \phi = 1$$

$$\therefore 6350^2 = (0 + 100 \times 0.4)^2 + (7142 - 100X_s)^2$$

$$\therefore 100 X_s = 790 \text{ or } X_s = 7.9 \Omega$$

F.L. current

$$I = \frac{3 \times 10^6}{\sqrt{3} \times 11,000} = 157 \text{ A}$$

$$IR_a = 0.4 \times 157 = 63 \text{ V; } IX_s = 157 \times 7.9 = 1240 \text{ V}$$

$$\therefore E_0 = [(6350 \times 0.8 + 63)^2 + (6350 \times 0.6 + 1240)^2]^{1/2} = 7210 \text{ V/phase}$$

$$\therefore \% \text{ regn} = \frac{7210 - 6350}{6350} \times 100 = 13.5\%$$

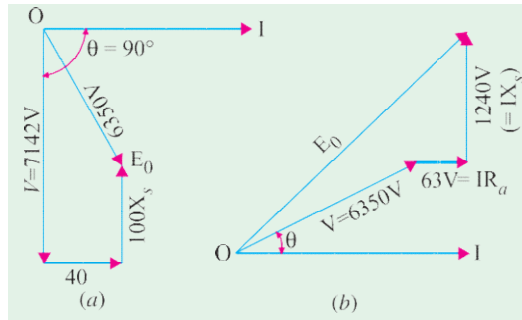

Fig. 37.42

Example 37.29. A straight line law connects terminal voltage and load of a 3-phase star-connected alternator delivering current at 0.8 power factor lagging. At no-load, the terminal voltage is 3,500 V and at full-load of 2,280 kW, it is 3,300 V. Calculate the terminal voltage when delivering current to a 3- ϕ , star-connected load having a resistance of 8 Ω and a reactance of 6 Ω per phase. Assume constant speed and field excitation.

(London Univ.)

Solution. No-load phase voltage = $3,500/\sqrt{3} = 2,021$ V

Phase voltage on full-load and 0.8 power factor = $3,300/\sqrt{3} = 1,905$ V

Full-load current is given by

$$\sqrt{3} V_L I_L \cos \phi = 2,280 \times 1000 \quad \therefore I_L = \frac{2,280 \times 1000}{\sqrt{3} \times 3,300 \times 0.8} = 500 \text{ A}$$

drop in terminal voltage/phase for 500 A = $2,021 - 1,905 = 116$ V

Let us assume that alternator is supplying a current of x ampere.

Then, drop in terminal voltage per phase for x ampere is = $116 x / 500 = 0.232 x$ volt

$$\therefore \text{terminal p.d./phase when supplying } x \text{ amperes at a p.f. of 0.8 lagging is} \\ = 2,021 - 0.232 x \text{ volt}$$

$$\text{Impedance of connected load/phase} = \sqrt{(8^2 + 6^2)} = 10 \Omega$$

$$\text{load p.f.} = \cos \phi = 8/10 = 0.8$$

When current is x , the applied p.d. is = $10 x$

$$\therefore 10 x = 2021 - 0.232 x \quad \text{or} \quad x = 197.5 \text{ A}$$

$$\therefore \text{terminal voltage/phase} = 2021 - (0.232 \times 197.5) = 1975.2 \text{ V}$$

$$\therefore \text{terminal voltage of alternator} = 1975.2 \times \sqrt{3} = \mathbf{3,421 \text{ V}}$$

Tutorial Problem No. 37.2

- If a field excitation of 10 A in a certain alternator gives a current of 150 A on short-circuit and a terminal voltage of 900 V on open-circuit, find the internal voltage drop with a load current of 60 A. **[360 V]**
- A 500-V, 50-kVA, 1- ϕ alternator has an effective resistance of 0.2 Ω . A field current of 10 A produces an armature current of 200 A on short-circuit and an e.m.f. of 450 V on open-circuit. Calculate the full-load regulation at p.f. 0.8 lag. **[34.4%]**
(Electrical Technology, Bombay Univ. 1978)
- A 3- ϕ star-connected alternator is rated at 1600 kVA, 13,500 V. The armature effective resistance and synchronous reactance are 1.5 Ω and 30 Ω respectively per phase. Calculate the percentage regulation for a load of 1280 kW at power factors of (a) 0.8 leading and (b) 0.8 lagging. **[(a) -11.8% (b) 18.6%]** *(Elect. Engg.-II, Bombay Univ. 1977)*
- Determine the voltage regulation of a 2,000-V, 1-phase alternator giving a current of 100 A at 0.8 p.f. leading from the test results. Full-load current of 100 A is produced on short-circuit by a field excitation of 2.5 A. An e.m.f. of 500 V is produced on open-circuit by the same excitation. The armature resistance is 0.8 Ω . Draw the vector diagram. **[- 8.9%]** *(Electrical Machines-I, Gujarat Univ. Apr. 1976)*
- In a single-phase alternator, a given field current produces an armature current of 250 A on short-circuit and a generated e.m.f. of 1500 V on open-circuit. Calculate the terminal p.d. when a load of 250 A at 6.6 kV and 0.8 p.f. lagging is switched off. Calculate also the regulation of the alternator at the given load. **[7,898 V; 19.7%]** *(Elect. Machines-II, Indore Univ. Dec. 1977)*
- A 500-V, 50-kVA, single-phase alternator has an effective resistance of 0.2 Ω . A field current of 10 A produces an armature current of 200 A on short-circuit and e.m.f. of 450 V on open circuit. Calculate (a) the synchronous impedance and reactance and (b) the full-load regulation with 0.8 p.f. lagging. **[(a) 2.25 Ω , 2.24 Ω , (b) 34.4%]** *(Elect. Technology, Mysore Univ. 1979)*

7. A 100-kVA, 3,000-V, 50-Hz, 3-phase star-connected alternator has effective armature resistance of 0.2Ω . A field current of 40 A produces short-circuit current of 200 A and an open-circuit e.m.f. of 1040 V (line value). Calculate the full-load percentage regulation at a power factor of 0.8 lagging. How will the regulation be affected if the alternator delivers its full-load output at a power factor of 0.8 leading?

[24.4% – 13.5%] (Elect. Machines-II, Indore Univ. July 1977)

8. A 3- ϕ , 50-Hz, star-connected, 2,000 kVA, 2,300-V alternator gives a short-circuit current of 600 A for a certain field excitation. With the same excitation, the O.C. voltage was 900 V. The resistance between a pair of terminals was 0.12Ω . Find full-load regulation at (a) u.p.f. (b) 0.8 p.f.lagging (c) 0.8 p.f. leading.

[(a) 7.3% (b) 23.8% (c) -13.2%] (Elect. Machinery-III, Bangalore Univ. Aug. 1979)

9. A 3-phase star-connected alternator is excited to give 6600 V between lines on open circuit. It has a resistance of 0.5Ω and synchronous reactance of 5Ω per phase. Calculate the terminal voltage and regulation at full load current of 130 A when the P.F. is (i) 0.8 lagging, (ii) 0.6 leading.

[Rajive Gandhi Technical University, Bhopal, 2000]

[(i) 3318 Volts/Ph, + 14.83% (ii) 4265 Volts/Ph, - 10.65%]

Rothert's M.M.F. or Ampere-turn Method

This method also utilizes O.C. and S.C. data, but is the converse of the E.M.F. method in the sense *that armature leakage reactance is treated as an additional armature reaction*. In other words, it is assumed that the change in terminal p.d. on load is due entirely to armature reaction (and due to the ohmic resistance drop which, in most cases, is negligible). This fact is shown in Fig. 37.43.

Now, field A.T. required to produce a voltage of V on full-load is the vector sum of the following :

(i) Field A.T. required to produce V (or if R_a is to be taken into account, then $V + IR_a \cos \phi$) on no-load. This can be found from O.C.C. and

(ii) Field A.T. required to overcome the demagnetising effect of armature reaction on full-load. This value is found from short-circuit test. The field A.T. required to produce full-load current on short-circuit balances the armature reaction and the *impedance drop*.

The impedance drop can be neglected because R_a is usually very small and X_s is also small under short-circuit conditions. Hence, p.f. on short-circuit is almost zero lagging and the field A.T. are used entirely to overcome the armature reaction which is wholly demagnetising (Art. 37.15). *In other words, the demagnetising armature A.T. on full-load are equal and opposite to the field A.T. required to produce full-load current on short-circuit.*

Now, if the alternator, instead of being on short-circuit, is supplying full-load current at its normal voltage and zero p.f. lagging, then total field A.T. required are the vector sum of

(i) the field A.T. = OA necessary to produce normal voltage (as obtained from O.C.C.) and

(ii) the field A.T. necessary to neutralize the armature reaction AB_1 . The total field A.T. are represented by OB_1 in Fig. 37.44 (a) and equals the vector sum of OA and AB_1

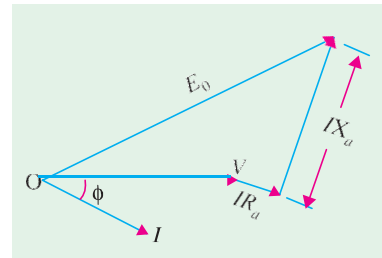

Fig. 37.43

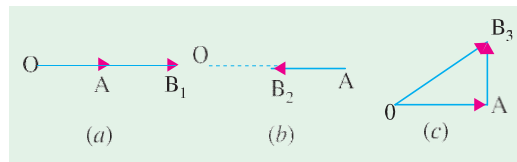

Fig. 37.44

(ii) the field A.T. necessary to neutralize the armature reaction AB_1 . The total field A.T. are represented by OB_1 in Fig. 37.44 (a) and equals the vector sum of OA and AB_1

If the p.f. is zero leading, the armature reaction is *wholly magnetising*. Hence, in that case, the field A.T. required is OB_2 which is less than OA by the field A.T. = AB_2 required to produce full-load current on short-circuit [Fig. 37.44 (b)]

If p.f. is unity, the armature reaction is *cross-magnetising i.e.* its effect is distortional only. Hence, field A.T. required is OB_3 i.e. vector sum of OA and AB_3 which is drawn at right angles to OA as in Fig. 37.44 (c).

General Case

Let us consider the general case when the p.f. has any value between zero (lagging or leading) and unity. Field ampere-turns OA corresponding to V (or $V + IR_a \cos \phi$) is laid off horizontally. Then AB_1 , representing full-load short-circuit field A.T. is drawn at an angle of $(90^\circ + \phi)$ for a lagging p.f. The total field A.T. are given by OB_1 as in Fig. 37.45. (a). For a leading p.f., short-circuit A.T. = AB_2 is drawn at an angle of $(90^\circ - \phi)$ as shown in Fig. 37.45 (b) and for unity p.f., AB_3 is drawn at right angles as shown in Fig. 37.45 (c).

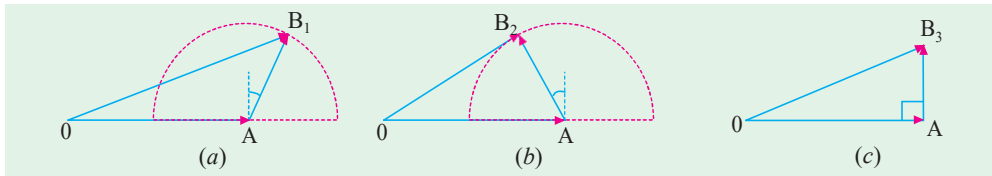

Fig. 37.45

In those cases where the number of turns on the field coils is not known, it is usual to work in terms of the field current as shown in Fig. 37.46.

In Fig. 37.47. is shown the complete diagram along with O.C. and S.C. characteristics. OA represents field current for normal voltage V . OC represents field current required for producing full-load current on short-circuit. Vector $AB = OC$ is drawn at an angle of $(90^\circ + \phi)$ to OA (if the p.f. is lagging). The total field current is OB for which the corresponding O.C. voltage is E_0

$$\therefore \% \text{ regn.} = \frac{E_0 - V}{V} \times 100$$

It should be noted that this method gives results which are less than the actual results, that is why it is sometimes referred to as optimistic method.

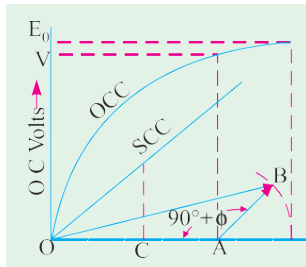

Fig. 37.46

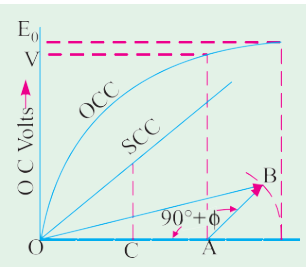

Fig. 37.47

Example 37.30. A 3.5-MVA, Y-connected alternator rated at 4160 volts at 50-Hz has the open-circuit characteristic given by the following data :

Field Current (Amps)	50	100	150	200	250	300	350	400	450
E.M.F. (Volts)	1620	3150	4160	4750	5130	5370	5550	5650	5750

A field current of 200 A is found necessary to circulate full-load current on short-circuit of the alternator. Calculate by (i) synchronous impedance method and (ii) ampere-turn method the full-load voltage regulation at 0.8 p.f. lagging. Neglect resistance. Comment on the results obtained.

(Electrical Machines-II, Indore Univ. 1984)

Solution. (i) As seen from the given data, a field current of 200 A produces O.C. voltage of 4750 (line value) and full-load current on short-circuit which is

$$= 3.5 \times 10^6 / \sqrt{3} \times 4160 = 486 \text{ A}$$

$$Z_S = \frac{\text{O.C. volt/phase}}{\text{S.C. current/phase}} = \frac{4750/\sqrt{3}}{486} = \frac{2740}{486} = 5.64 \Omega / \text{phase}$$

Since $R_a = 0, X_S = Z_S \therefore IR_a = 0, IX_S = IZ_S = 486 \times 5.64 = 2740 \text{ V}$

$$\text{F.L. Voltage/phase} = 4160/\sqrt{3} = 2400 \text{ V}, \cos \phi = 0.8, \sin \phi = 0.6$$

$$E_0 = (V \cos \phi + IR_a)^2 + (V \sin \phi + IX_S)^2)^{1/2}$$

$$= [(2400 \times 0.8 + 0)^2 + (2400 \times 0.6 + 2740)^2]^{1/2} = 4600 \text{ V}$$

$$\% \text{ regn. up} = \frac{4600 - 2400}{2400} \times 100 = \mathbf{92.5\%}$$

(ii) It is seen from the given data that for normal voltage of 4160 V, field current needed is 150 A. Field current necessary to circulate F.L. current on short-circuit is 200 A.

In Fig. 37.48, OA represents 150 A. The vector AB which represents 200 A is vectorially added to OA at $(90^\circ + \phi) = (90^\circ + 36^\circ 52') = 126^\circ 52'$. Vector OB represents excitation necessary to produce a terminal p.d. of 4160 V at 0.8 p.f. lagging at full-load.

$$OB = [150^2 + 200^2 + 2 \times 150 \times 200 \times \cos(180^\circ - 126^\circ 52')]^{1/2}$$

$$= 313.8 \text{ A}$$

The generated phase e.m.f. E_0 , corresponding to this excitation as found from OCC (if drawn) is 3140 V. Line value is $3140 \times \sqrt{3} = 5440 \text{ V}$.

$$\% \text{ regn.} = \frac{5440 - 4160}{4160} \times 100 = \mathbf{30.7\%}$$

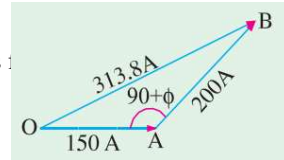

Fig. 37.48

Example 37.31. The following test results are obtained on a 6,600-V alternator:

Open-circuit voltage :	3,100	4,900	6,600	7,500	8,300
Field current (amps) :	16	25	37.5	50	70

A field current of 20 A is found necessary to circulate full-load current on short-circuit of the armature. Calculate by (i) the ampere-turn method and (ii) the synchronous impedance method the full-load regulation at 0.8 p.f. (lag). Neglect resistance and leakage reactance. State the drawbacks of each of these methods. **(Elect. Machinery-II, Bangalore Univ. 1992)**

Solution. (i) Ampere-turn Method

It is seen from the given data that for the normal voltage of 6,600 V, the field current needed is 37.5 A. Field-current for full-load current, on short-circuit, is given as 20 A.

In Fig. 37.49, OA represents 37.5 A. The vector AB , which represents 20 A, is vectorially added to OA at $(90^\circ + 36^\circ 52') = 126^\circ 52'$. Vector OB represents the excitation necessary to produce a terminal p.d. of 6,600 V at 0.8 p.f. lagging on full-load

$$OB = \sqrt{37.5^2 + 20^2 + 2 \times 37.5 \times 20 \times \cos 53^\circ 8'} \approx 2 \text{ A}$$

The generated e.m.f. E_0 corresponding to this excitation, as found from O.C.C. of Fig. 37.49 is 7,600 V.

$$\text{Percentage regulation} = \frac{E_0 - V}{V} \times 100 = \frac{7,600 - 6,600}{6,600} \times 100 = 15.16\%$$

(ii) Synchronous Impedance Method

Let the voltage of 6,600 V be taken as 100 per cent and also let 100 per cent excitation be that which is required to produce 6,600 V on open-circuit, that is, the excitation of 37.5 A.

Full-load or 100 per cent armature current is produced on short-circuit by a field current of 20 A. If 100 per cent field current were applied on short-circuit, then S.C. current would be $100 \times 37.5/20 = 187.5$ per cent.

$$\therefore Z_s = \frac{\text{O.C. voltage}}{\text{S.C. current}} \Bigg|_{\text{same excitation}}$$

$$= 100/187.5 \text{ or } 0.533 \text{ or } 53.3\%$$

The impedance drop IZ_s is equal to 53.3% of the normal voltage. When the two are added vectorially (Fig. 37.50), the value of voltage is

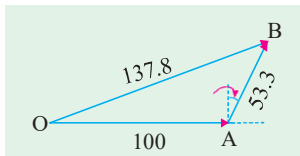

Fig. 37.50

$$E_0 = \sqrt{[100 + 53.3 \cos(90 - \phi)]^2 + [53.3 \sin(90 - \phi)]^2}$$

$$= \sqrt{(100 + 53.3 \times 0.6)^2 + (53.3 \times 0.8)^2} = 138.7\%$$

$$\% \text{ reg} = \frac{138.7 - 100}{100} \times 100 = 38.7\%$$

The two value of regulation, found by the two methods, are found to differ widely from each other. The first method gives somewhat lesser value, while the other method gives a little higher value as compared to the actual value. However, the first value is more likely to be nearer the actual value, because the second method employs Z_s , which does not have a constant value. Its value depends on the field excitation.

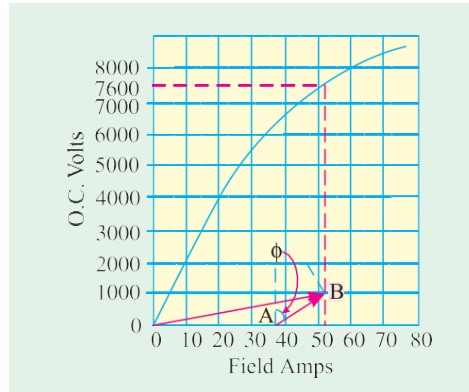

Fig. 37.49

Example 37.32. The open-and short-circuit test readings for a 3- ϕ , star-connected, 1000-kVA, 2000 V, 50-Hz, synchronous generator are :

Field Amps ;	10	20	25	30	40	50
O.C. Terminal V	800	1500	1760	2000	2350	2600
S.C. armature current in A:	—	200	250	300	—	—

The armature effective resistance is 0.2 Ω per phase. Draw the characteristic curves and estimate the full-load percentage regulation at (a) 0.8 p.f. lagging (b) 0.8 p.f. leading.

Solution. The O.C.C. and S.C.C. are plotted in Fig. 37.51

The phase voltages are : 462, 866, 1016, 1155, 1357, 1502.

Full-load phase voltage = $2000/\sqrt{3} = 1155$ V

Full-load current = $1,000,000/2000 \times \sqrt{3} = 288.7$ A

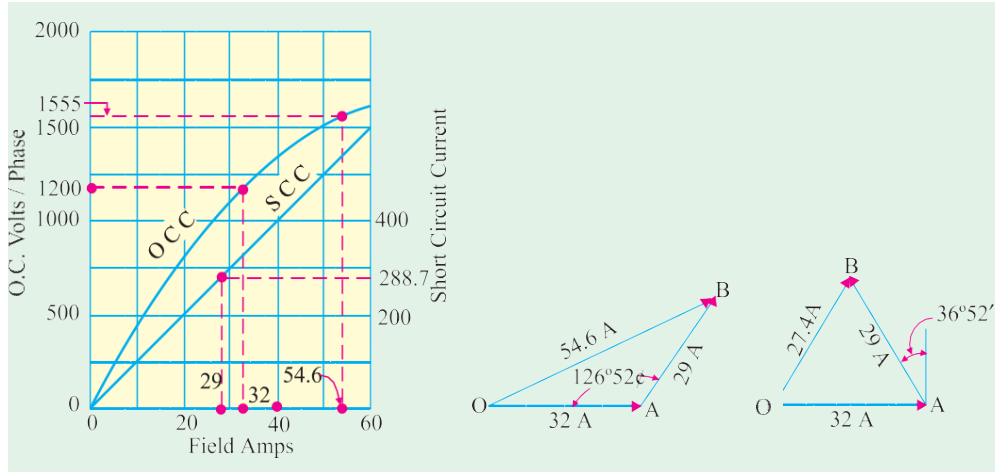

Fig. 37.51

Fig. 37.52

Fig. 37.53

Voltage/phase at full-load at 0.8 p.f. = $V + IR_a \cos \phi = 1155 + (288.7 \times 0.2 \times 0.8) = 1200$ volt

From open-circuit curve, it is found that field current necessary to produce this voltage = 32 A.

From short-circuit characteristic, it is found that field current necessary to produce full-load current of 288.7 A is = 29 A.

(a) $\cos \phi = 0.8, \phi = 36^\circ 52'$ (lagging)

In Fig. 37.52, $OA = 32$ A, $AB = 29$ A and is at an angle of $(90^\circ + 36^\circ 52') = 126^\circ 52'$ with OA . The total field current at full-load 0.8 p.f. lagging is $OB = 54.6$ A

O.C. volt corresponding to a field current of 54.6 A is = 1555 V

% regn. = $(1555 - 1155) \times 100 / 1155 = 34.6\%$

(b) In this case, as p.f. is leading, AB is drawn with OA (Fig. 37.53) at an angle of $90^\circ - 36^\circ 52' = 53^\circ 8'$; $OB = 27.4$ A.

O.C. voltage corresponding to 27.4 A of field excitation is 1080 V.

$$\% \text{ regn.} = \frac{1080 - 1155}{1155} \times 100 = -6.4\%$$

Example 37.33. A 3-phase, 800-kVA, 3,300-V, 50-Hz alternator gave the following results:

Exciting current (A)	50	60	70	80	90	100
O.C. volt (line)	2560	3000	3300	3600	3800	3960
S.C. current	190	—	—	—	—	—

The armature leakage reactance drop is 10% and the resistance drop is 2% of the normal voltage. Determine the excitation at full-load 0.8 power factor lagging by the m.m.f. method.

Solution. The phase voltages are : 1478, 1732, 1905, 2080, 2195, 2287

The O.C.C. is drawn in Fig. 37.54.

Normal phase voltage = $3300 / \sqrt{3} = 1905$ V; IR_a drop = 2% of 1905 = 38.1 volt

Leakage reactance drop = 10% of 1905 = 190.5 Volt

$$\therefore E = \sqrt{[(1905 \times 0.8 + 38.1)^2 + (1905 \times 0.6 + 190.5)^2]} = 2,068 \text{ V}$$

The exciting current required to produce this voltage (as found from O.C.C.) is 82 A.

$$\text{Full load current} = 800,000 / \sqrt{3} \times 3300 = 140 \text{ A}$$

As seen from S.C.C., the exciting current required to produce this full-load current of 140 A on short-circuit is 37 A.

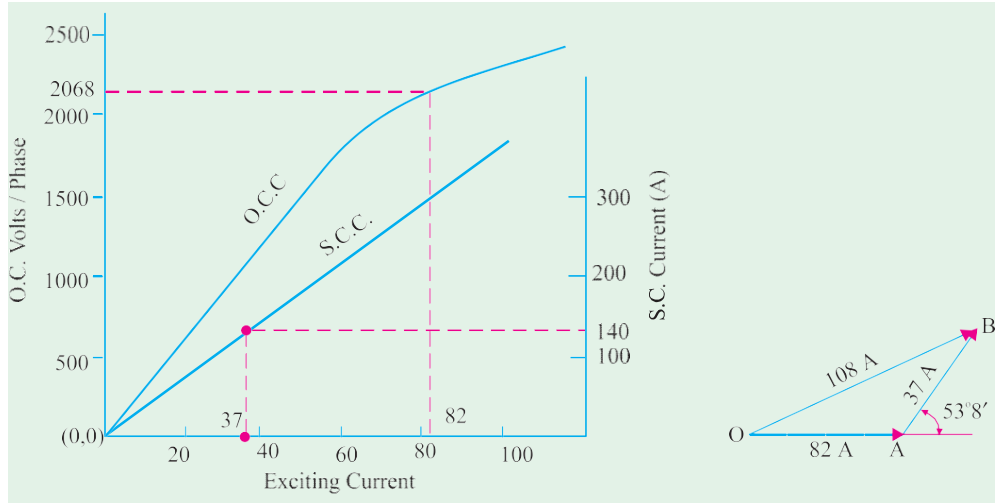

Fig. 37.54

Fig. 37.55

In Fig. 37.55, *OB* gives the excitation required on full-load to give a terminal phase voltage of 1905 V (or line voltage of 3300 V) at 0.8 p.f. lagging and its value is

$$= \sqrt{82^2 + 37^2 + 2 \times 82 \times 37 \times \cos 53^\circ 8'} = 108 \text{ A}$$

Tutorial Problem No. 37.3

1. A 30-kVA, 440-V, 50-Hz, 3- ϕ , star-connected synchronous generator gave the following test data :

Field current (A)	: 2	4	6	7	8	10	12	14
Terminal volts	: 155	287	395	440	475	530	570	592
S.C. current	: 11	22	34	40	46	57	69	80

Resistance between any two terminals is 0.3 Ω

Find regulation at full-load 0.8 p.f. lagging by (a) synchronous impedance method and (b) Rothert's ampere-turn method. Take Z_s corresponding to S.C. current of 80 A. [(a) 51% (b) 29.9%]

Zero Power Factor Method or Potier Method

This method is based on the separation of armature-leakage reactance drop and the armature reaction effects. Hence, it gives more accurate results. It makes use of the first two methods to some extent. The experimental data required is (i) no-load curve and (ii) full-load zero power factor curve (not the short-circuit characteristic) also called wattless load characteristic. It is the curve of terminal volts against excitation when armature is delivering F.L. current at zero p.f.

The reduction in voltage due to armature reaction is found from above and (ii) voltage drop due to armature leakage reactance X_L (also called Potier reactance) is found from both. By combining these two, E_0 can be calculated.

It should be noted that if we vectorially add to V the drop due to resistance and leakage reactance X_L , we get E . If to E is further added the drop due to armature reaction (assuming lagging p.f.), then we get E_0 (Art. 37.18).

The zero p.f. lagging curve can be obtained.

- (a) if a similar machine is available which may be driven at no-load as a synchronous motor at practically zero p.f. or
- (b) by loading the alternator with pure reactors
- (c) by connecting the alternator to a 3- ϕ line with ammeters and wattmeters connected for measuring current and power and by so adjusting the field current that we get full-load armature current with zero wattmeter reading.

Point *B* (Fig. 37.56) was obtained in this manner when wattmeter was reading zero. Point *A* is obtained from a short-circuit test with full-load armature current. Hence, *OA* represents field current which is equal and opposite to the demagnetising armature reaction and for balancing leakage reactance drop at full-load (please refer to A.T. method). Knowing these two points, full-load zero p.f. curve *AB* can be drawn as under.

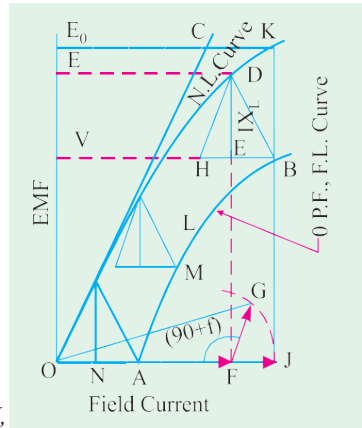

Fig. 37.56

From *B*, *BH* is drawn equal to and parallel to *OA*. From *H*, *HD* is drawn parallel to initial straight part of *N-L* curve *i.e.* parallel to *OC*, which is tangential to *N-L* curve. Hence, we get point *D* on no-load curve, which corresponds to point *B* on full-load zero p.f. curve. The triangle *BHD* is known as Potier triangle. This triangle is constant for a given armature current and hence can be transferred to give us other points like *M*, *L* etc. Draw *DE* perpendicular to *BH*. The length *DE* represents the drop in voltage due to armature leakage reactance X_L *i.e.* $I X_L$. *BE* gives field current necessary to overcome demagnetising effect of armature reaction at full-load and *EH* for balancing the armature leakage reactance drop *DE*.

Let *V* be the terminal voltage on full-load, then if we add to it vectorially the voltage drop due to armature leakage reactance alone (neglecting R_a), then we get voltage $E = DF$ (and not E_0). Obviously, field excitation corresponding to *E* is given by *OF*. *NA* (= *BE*) represents the field current needed to overcome armature reaction. Hence, if we add *NA* vectorially to *OF* (as in Rothert's A.T. method) we get excitation for E_0 whose value can be read from *N-L* curve.

In Fig. 37.56, *FG* (= *NA*) is drawn at an angle of $(90^\circ + \phi)$ for a lagging p.f. (or it is drawn at an angle of $90^\circ - \phi$ for a leading p.f.). The voltage corresponding to this excitation is $JK = E_0$

$$\therefore \% \text{ regn.} = \frac{E_0 - V}{V} \times 100$$

The vector diagram is also shown separately in Fig. 37.57.

Assuming a lagging p.f. with angle ϕ , vector for *I* is drawn at an angle of ϕ to *V*. $I R_a$ is drawn parallel to current vector and $I X_L$ is drawn perpendicular to it. *OD* represents voltage *E*. The excitation corresponding to it *i.e.* *OF* is drawn at 90° ahead of it. *FG* (= *NA* = *BE* in Fig. 37.56) representing field current equivalent of full-load armature reaction, is drawn parallel to current vector *OI*. The closing side *OG* gives field excitation for E_0 .

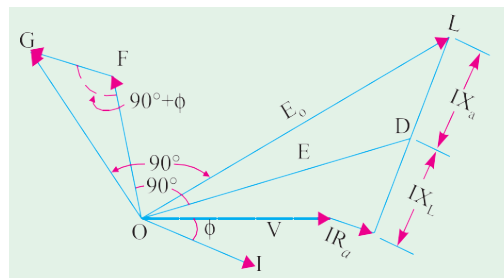

Fig. 37.57

Vector for E_0 is 90° lagging behind *OG*. *DL* represents voltage drop due to armature reaction.

Pro cedural Steps for Potier Method 1.

1. Suppose we are given *V*-the terminal voltage/phase.
2. We will be given or else we can calculate armature leakage reactance X_L and hence can calculate $I X_L$.

3. Adding IX_L (and IR_a if given) vectorially to V , we get voltage E .
4. We will next find from $N-L$ curve, field excitation for voltage E . Let it be i_{f1} .
5. Further, field current i_{f2} necessary for balancing armature reaction is found from Potier triangle.
6. Combine i_{f1} and i_{f2} vectorially (as in $A.T.$ method) to get i_f .
7. Read from $N-L$ curve, the e.m.f. corresponding to i_f . This gives us E_0 . Hence, regulation can be found.

Example 37.34. A 3-phase, 6,00-V alternator has the following O.C.C. at normal speed :

Field amperes :	14	18	23	30	43
Terminal volts :	4000	5000	6000	7000	8000

With armature short-circuited and full-load current flowing the field current is 17 A and when the machine is supplying full-load of 2,000 kVA at zero power factor, the field current is 42.5 A and the terminal voltage is 6,000 V.

Determine the field current required when the machine is supplying the full-load at 0.8 p.f. lagging. (A.C. Machines-I, Jadavpur Univ. 1988)

Solution. The O.C.C. is drawn in Fig. 37.58 with phase voltages which are 2310, 2828, 3465 4042 4620

The full-load zero p.f. characteristic can be drawn because two points are known i.e. (17, 0) and (42.5, 3465).

In the Potier ΔBDH , line DE represents the leakage reactance drop ($= IX_L$) and is (by measurement) equal to 450 V. As seen from Fig. 37.59.

$$E = \sqrt{(V \cos \phi)^2 + (V \sin \phi + IX_L)^2}$$

$$= \sqrt{(3465 \times 0.8)^2 + (3465 \times 0.6 + 450)^2}$$

$$= 3750 \text{ V}$$

From O.C.C. of Fig. 37.58, it is found that field amperes required for this voltage = 26.5 A.

Field amperes required for balancing armature reaction = $BE = 14.5$ A (by measurement from Potier triangle BDH).

As seen from Fig. 37.60, the field currents are added vectorially at an angle of $(90^\circ + \phi) = 126^\circ 52'$.

Resultant field current is $OB = \sqrt{26.5^2 + 14.5^2 + 2 \times 26.5 \times 14.4 \cos 53^\circ 8'} = 37.2 \text{ A}$

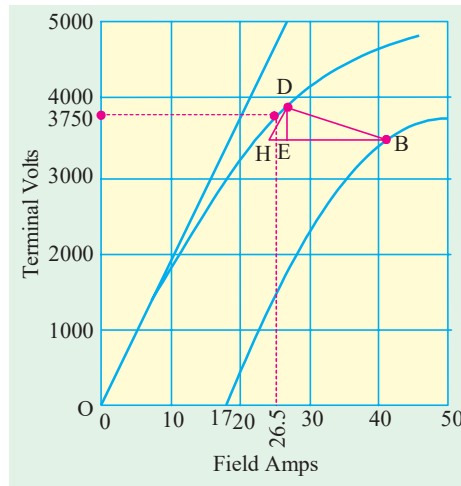

Fig. 37.58

Example 37.35. An 11-kV, 1000-kVA, 3-phase, Y-connected alternator has a resistance of 2Ω per phase. The open-circuit and full-load zero power factor characteristics are given below. Find the voltage regulation of the alternator for full load current at 0.8 p.f. lagging by Potier method.

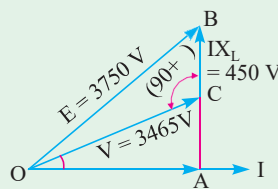

Fig. 37.59

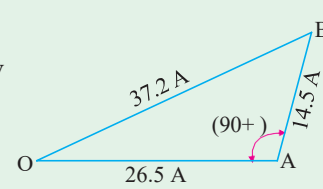

Fig. 37.60

Field current (A)	:	40	50	110	140	180
O.C.C. line voltage	:	5,800	7,000	12,500	13,750	15,000
Line volts zero p.f.	:	0	1500	8500	10,500	12,500

(Calcutta Univ. 1987 and S. Ramanandtirtha Univ. Nanded, 2001)

Solution. The O.C.C. and full-load zero p.f. curve for phase voltage are drawn in Fig. 37.61. The corresponding phase voltages are :

O.C.C. phase voltage	3350	4040	7220	7940	8660
Phase voltage zero p.f.	0	866	4900	6060	7220

Full-load current = $1000 \times 1000 / \sqrt{3} \times 11,000 = 52.5 \text{ A}$

Phase voltage = $11,000 / \sqrt{3} = 6,350 \text{ A}$

In the Potier ΔABC , $AC = 40 \text{ A}$, CB is parallel to the tangent to the initial portion of the O.C.C. and BD is \perp to AC .

$BD =$ leakage reactance drop $IX_L = 1000 \text{ V}$ – by measurement

$AD = 30 \text{ A}$ — field current required to overcome demagnetising effect of armature reaction on full-load.

As shown in Fig. 37.62,

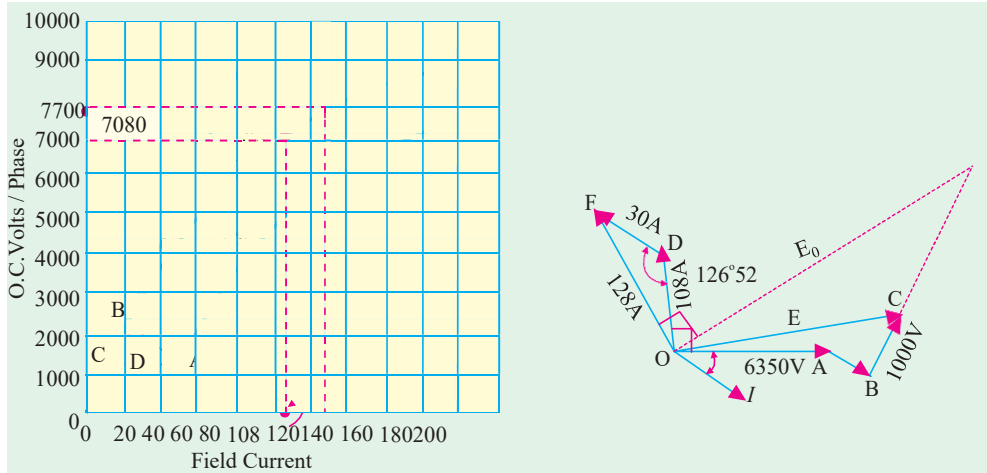

Fig. 37.61

Fig. 37.62

$OA = 6,350 \text{ V}; AB = IR_a = 52.5 \times 2 = 105 \text{ V}$

$IX_L = BC = 1000 \text{ V}$ —by measurement

$$OC = E = \sqrt{(V \cos \phi + IR_a)^2 + (V \sin \phi + IX_L)^2}$$

$$= \sqrt{(6350 \times 0.8 + 105)^2 + (6350 \times 0.6 + 1000)^2}; E = 7,080 \text{ V}$$

As seen from O.C.C., field current required for 7,080 V is 108 A. Vector OD (Fig. 37.62) represents 108 A and is drawn \perp to OC . DF represents 30 A and is drawn parallel to OI or at $(90^\circ + 36^\circ 52') = 126^\circ 52'$ with OD . Total field current is OF .

$$OF = \sqrt{108^2 + 30^2 + 2 \times 108 \times 30 \cos 53^\circ 8'} = 128 \text{ A}$$

From O.C.C., it is found that the e.m.f. corresponding to this field current is 7,700 V

$\therefore E_0 = 7,700 \text{ V}; \text{regulation} = \frac{7,700 - 6,350}{6,350} \times 100 = 21.3 \text{ per cent}$

Example 37.36. The following test results were obtained on a 275-kW, 3- ϕ , 6,600-V non-salient pole type generator.

Open-circuit characteristic :

Volts	:	5600	6600	7240	8100
Exciting amperes	:	46.5	58	67.5	96

Short-circuit characteristic : Stator current 35 A with an exciting current of 50 A. Leakage reactance on full-load = 8%. Neglect armature resistance. Calculate as accurately as possible the exciting current (for full-load) at power factor 0.8 lagging and at unity. (City & Guilds, London)

Solution. First convert the O.C. line volts into phase volts by dividing the given terminal values by $\sqrt{3}$.
 \therefore O.C. volts (phase) : 3233, 3810, 4180, 4677.

O.C.C. is plotted in Fig. 37.63. For plotting S.C.C., we need two points. One is (0, 0) and the other is (50 A, 35 A). In fact, we can do without plotting the S.C.C. because it being a straight line, values of field currents corresponding to any armature current can be found by direct ratio.

$$\text{Leakage reactance drop} = \frac{3810 \times 8}{100} = 304.8 \text{ V}$$

$$\text{Normal phase voltage} = 6,600 / \sqrt{3} = 3,810 \text{ V}$$

In Fig. 37.64, $OA = 3810 \text{ V}$ and at an angle ϕ ahead of current vector OI . $AB = 304.8 \text{ V}$ is drawn at right angles to OI . Resultant of the two is $OB = 4010 \text{ V}$. From O.C.C., field current corresponding to 4,010 V is 62 A.

$$\text{Full-load current at } 0.8 \text{ p.f.} = 275,000 / \sqrt{3} \times 6600 \times 0.8 = 30 \text{ A}$$

35 A of armature current need 50 A of field current, hence 30 A of armature current need $30 \times 50/35 = 43 \text{ A}$.

In Fig. 37.64, $OC = 62 \text{ A}$ is drawn at right angles to OB . Vector $CD = 43 \text{ A}$ is drawn parallel to OI . Then, $OD = 94.3 \text{ A}$

Note. Here, 43 A pf field excitation is assumed as having all been used for balancing armature reaction. In fact, a part of it is used for balancing armature leakage drop of 304.8 V. This fact has been clarified in the next example.

At Unity p.f.

In Fig. 37.65, OA again represents $V = 3810 \text{ V}$, $AB = 304.8 \text{ V}$ and at right angles to OA .

$$\text{The resultant } OB = \sqrt{(3810^2 + 304.8^2)} = 3830 \text{ V}$$

Field current from O.C.C. corresponding to this voltage = 59.8 A.

Hence, $OC = 59.8 \text{ A}$ is drawn perpendicular to OB (as before)

$$\text{Full-load current at u.p.f.} = 275,000 / \sqrt{3} \times 6600 \times 1 = 24 \text{ A}$$

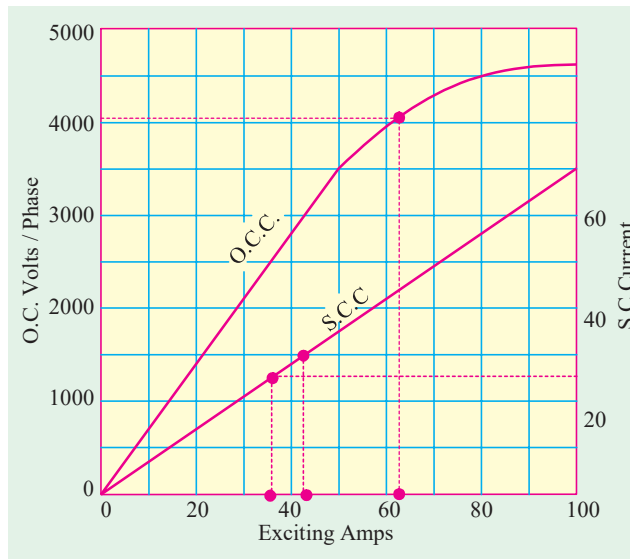

Fig. 37.63

Now, 35 A armature current corresponds to a field current of 50 A, hence 24 A of armature current corresponds to $50 \times 24/35 = 34.3$ A.

Hence, $CD = 34.3$ A is drawn \parallel to OA (and \perp to OC approximately).*

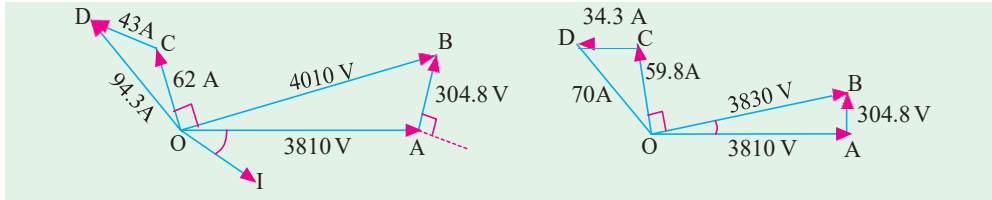

Fig. 37.64

Fig. 37.65

$$\therefore OD = \sqrt{(59.8^2 + 34.3^2)} = 70 \text{ A}$$

Example 37.37. A 600-kVA, 3,300-V, 8-pole, 3-phase, 50-Hz alternator has following characteristic :

Amp-turns/pole : 4000 5000 7000 10,000

Terminal E.M.F. : 2850 3400 3850 4400

There are 200 conductor in series per phase.

Find the short-circuit characteristic, the field ampere-turns for full-load 0.8 p.f. (lagging) and the voltage regulation, having given that the inductive drop at full-load is 7% and that the equivalent armature reaction in amp-turns per pole = $1.06 \times$ ampere-conductors per phase per pole.

(London Univ.)

Solution. O.C. terminal voltages are first converted into phase voltages and plotted against field amp-turns, as shown in Fig. 37.66.

Full-load current

$$= \frac{600,000}{\sqrt{3} \times 3300} = 105 \text{ A}$$

Demagnetising amp-turns per pole per phase for full-load at zero p.f.

$$= 1.06 \times 105 \times 200/8 = 2,780$$

Normal phase voltage

$$= 3300 / \sqrt{3} = 1910 \text{ volt}$$

Leakage reactance drop

$$= \frac{3300 \times 7}{\sqrt{3} \times 100} = 133 \text{ V}$$

In Fig. 37.67, OA represents 1910 V.

AB = 133 V is drawn \perp to OI, OB is the resultant voltage E (not E_0).

$$\therefore OB = E = 1987 \text{ volt}$$

From O.C.C., we find that 1987 V correspond to 5100 field amp-turns. Hence, OC = 5100 is drawn \perp to OB. CD = 2780 is \parallel to OI. Hence, OD = 7240 (approx). From O.C.C. it is found that this

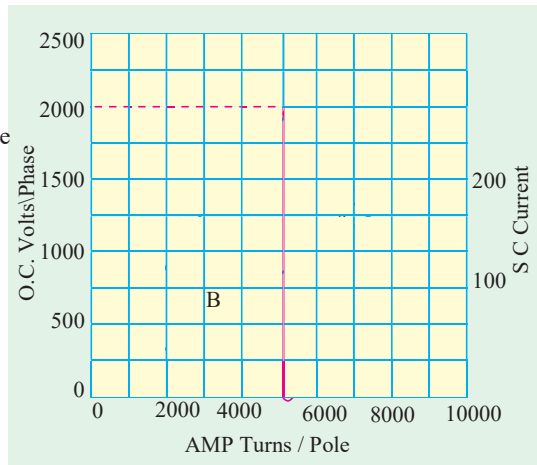

Fig. 37.66

* It is so because angle between OA and OB is negligibly small. If not, then CD should be drawn at an angle of $(90 + \alpha)$ where α is the angle between OA and OB.

corresponds to an O.C. voltage of 2242 volt. Hence, when load is thrown off, the voltage will rise to 2242 V.

$$\therefore \% \text{ regn.} = \frac{2242 - 1910}{1910} \times 100 = 17.6 \%$$

How to deduce S.C.C. ?

We have found that field amp-turns for balancing armature reaction only are 2,780. To this should be added field amp-turns required for balancing the leakage reactance voltage drop of 133 V.

Field amp-turns corresponding to 133 volt on O.C. are 300 approximately. Hence, with reference to Fig. 37.56, $NA = 2780$, $ON = 300$

$$\begin{aligned} \therefore \text{Short-circuit field amp-turns} \\ = OA = 2780 + 300 \\ = 3080 \end{aligned}$$

Hence, we get a point B on S.C.C. *i.e.* (3080, 105) and the other point is the origin. So S.C.C. (which is a straight line) can be drawn as shown in Fig. 37.66.

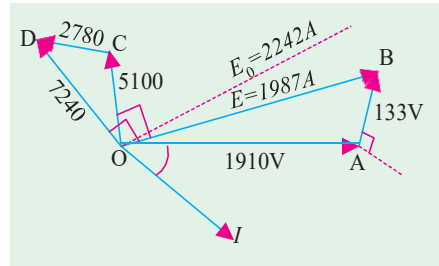

Fig. 37.67

Example 37.38. The following figures give the open-circuit and full-load zero p.f. saturation curves for a 15,000-kVA, 11,000 V, 3-φ, 50-Hz, star-connected turbo-alternator:

Field AT in 10^3	:	10	18	24	30	40	45	50
O.C. line kV	:	4.9	8.4	10.1	11.5	12.8	13.3	13.65
Zero p.f. full-load line kV	:	—	0	—	—	—	10.2	—

Find the armature reaction, the armature reactance and the synchronous reactance. Deduce the regulation for full-load at 0.8 power lagging.

Solution. First, O.C.C. is drawn between phase voltages and field amp-turns, as shown in Fig. 37.68.

Full-load, zero p.f. line can be drawn, because two points are known *i.e.* A (18, 0) and C (45, 5890). Other points on this curve can be found by transferring the Potier triangle. At point C, draw $CD \parallel$ to and equal to OA and from D draw $DE \parallel$ to ON. Join EC. Hence, CDE is the Potier triangle.

Line EF is \perp to DC

CF = field amp-turns for balancing armature-reaction only

$$= 15,700$$

$EF = GH = 640$ volt = leakage reactance drop/phase

Short-circuit A.T. required = $OA = 18,000$

$$\text{Full-load current} = \frac{15,000 \times 1000}{\sqrt{3} \times 11,000} = 788 \text{ A}$$

$$\therefore 640 = I \times X_L \quad \therefore X_L = 640/788 = 0.812 \Omega$$

From O.C.C., we find that 18,000 A.T. correspond to an O.C. voltage of $8,400/\sqrt{3} = 4,850$ V.

$$\begin{aligned} \therefore Z_s &= \frac{\text{O.C. volt}}{\text{S.C. current}} = \frac{4,850}{788} \\ &= 6.16 \Omega \end{aligned}$$

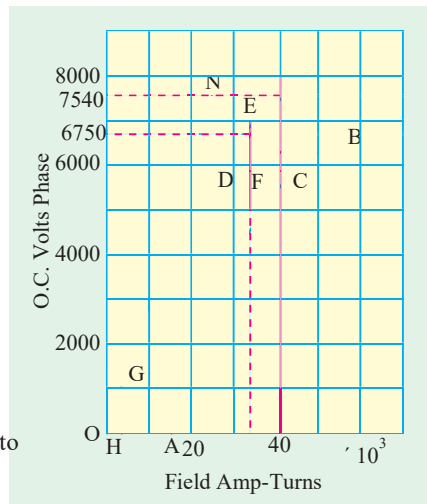

Fig. 37.68

(Art. 37.21)

As R_a is negligible, hence Z_S equals X_S .

Regulation

In Fig. 37.69, $OA =$ phase voltage $= 11,000/\sqrt{3}$
 $= 6,350$ V

$AB = 640$ V and is drawn at right angles to OI or at $(90^\circ + \phi)$ to OA .

Resultant is $OB = 6,750$ V

Field A.T. corresponding to O.C voltage of 6,750 V is $= OC = 30,800$ and is drawn \perp to OB .

$CD =$ armature reaction at F.L. $= 15,700$ and is drawn \parallel to OI or at $(90^\circ + \phi)$ to OC .

Hence, $OD = 42,800$.

From O.C.C., e.m.f. corresponding to 42,800 A.T. of rotor $= 7,540$ V

\therefore % regn. up $= (7,540 - 6,350)/6,350 = 0.187$
 or **18.7%**

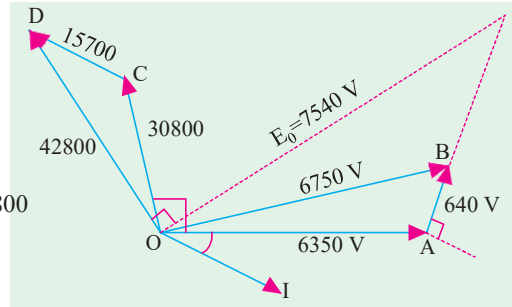

Fig. 37.69

Tutorial Problem No. 37.4

1. The following data relate to a 6,600-V, 10,000-kVA, 50-Hz, 3- ϕ , turbo- alternator:

O.C. kilovolt	4.25	5.45	6.6	7.3	8	9
Exciting A.T. in 10^3	60	80	100	120	145	220

Excitation needed to circulate full-load current on short circuit : 117,000 A.T. Inductive drop in stator winding at full-load $= 15\%$. Find the voltage regulation at full-load 0.8 power factor.

[34.4%] (City & Guilds, London)

2. Deduce the exciting current for a 3- ϕ , 3300-V generator when supplying 100 kW at 0.8 power factor lagging, given magnetisation curve on open-circuit :

Line voltage :	3300	3600	3900
Exciting current :	80	96	118

There are 16 poles, 144 slots, 5 conductors/slot, single-circuit, full-pitched winding, star- connected. The stator winding has a resistance per phase of 0.15Ω and a leakage reactance of 1.2Ω . The field coils have each 108 turns.

[124 A] (London Univ.)

3. Estimate the percentage regulation at full-load and power factor 0.8 lagging of a 1000-kVA, 6,600-V, 3- ϕ , 50-Hz, star-connected salient-pole synchronous generator. The open-circuit characteristic is as follows :

Terminal volt	4000	6000	6600	7200	8000
Field A.T.	5200	8500	10,000	12,500	17,500

Leakage reactance 10%, resistance 2%. Short-circuit characteristic : full-load current with a field excitation of 5000 A.T. Take the permeance to cross armature reaction as 35% of that to direct reaction. [20% up]

4. A 1000-kVA, 11,000-V, 3- ϕ , 50-Hz, star-connected turbo-generator has an effective resistance of 2Ω /phase. The O.C.C. and zero p.f. full-load data is as follows :

O.C. volt	5,805	7,000	12,550	13,755	15,000
Field current A	40	50	110	140	180
Terminal volt at F.L. zero p.f.	0	1500	8,500	10,500	12,400

Estimate the % regulation for F.L. at 0.8 p.f. lagging. [22 %]

5. A 5-MVA, 6.6 kV, 3- ϕ , star-connected alternator has a resistance of 0.075 Ω per phase. Estimate the regulation for a load of 500 A at p.f. (a) unity and (b) 0.9 leading (c) 0.71 lagging from the following open-circuit and full-load zero power factor curve.

Field current (A)	Open-circuit terminal voltage (V)	Saturation curve zero p.f.
32	3100	0
50	4900	1850
75	6600	4250
100	7500	5800
140	8300	7000

[(a) 6.3% (b) -7.9% (c) 20.2%] (Electrical Machines-II, Indore Univ. Feb. 1978)

Operation of a Salient Pole Synchronous Machine

A multipolar machine with cylindrical rotor has a uniform air-gap, because of which its reactance remains the same, irrespective of the spatial position of the rotor. However, a synchronous machine with salient or projecting poles has non-uniform air-gap due to which its reactance varies with the rotor position. Consequently, a cylindrical rotor machine possesses one axis of symmetry (pole axis or direct axis) whereas salient-pole machine possesses two axes of geometric symmetry (i) field poles axis, called direct axis or d -axis and (ii) axis passing through the centre of the interpolar space, called the quadrature axis or q -axis, as shown in Fig. 37.70.

Obviously, two mmfs act on the d -axis of a salient-pole synchronous machine i.e. field m.m.f. and armature m.m.f. whereas only one m.m.f., i.e. armature mmf acts on the q -axis, because field mmf has no component in the q -axis. The magnetic reluctance is low along the poles and high between the poles. The above facts form the basis of the two-reaction theory proposed by Blondel, according to which

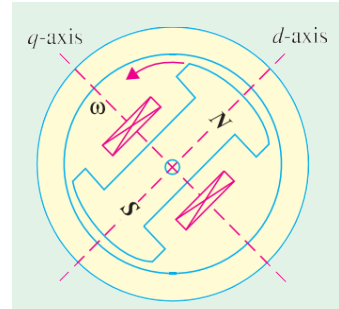

Fig. 37.70

- (i) armature current I_a can be resolved into two components i.e. I_d perpendicular to E_0 and I_q along E_0 as shown in Fig. 37.71 (b).
- (ii) armature reactance has two components i.e. q -axis armature reactance X_{aq} associated with I_d and d -axis armature reactance X_{ad} linked with I_q .

If we include the armature leakage reactance X_l which is the same on both axes, we get

$$X_d = X_{ad} + X_l \text{ and } X_q = X_{aq} + X_l$$

Since reluctance on the q -axis is higher, owing to the larger air-gap, hence,

$$X_{aq} < X_{ad} \text{ or } X_q < X_d \text{ or } X_d > X_q$$

Phasor Diagram for a Salient Pole Synchronous Machine

The equivalent circuit of a salient-pole synchronous generator is shown in Fig. 37.71 (a). The component currents I_d and I_q provide component voltage drops $jI_d X_d$ and $jI_q X_q$ as shown in Fig. 37.71 (b) for a lagging load power factor.

The armature current I_a has been resolved into its rectangular components with respect to the axis for excitation voltage E_0 . The angle ψ between E_0 and I_a is known as the internal power factor angle. The

vector for the armature resistance drop $I_a R_a$ is drawn parallel to I_a . Vector for the drop $I_d X_d$ is drawn perpendicular to I_d whereas that for $I_q X_q$ is drawn perpendicular to I_q . The angle δ between E_0 and V is called the power angle. Following phasor relationships are obvious from Fig. 37.71 (b)

$$E_0 = V + I_a R_a + jI_d X_d + jI_q X_q \text{ and } I_a = I_d + I_q$$

If R_a is neglected the phasor diagram becomes as shown in Fig. 37.72 (a). In this case,

$$E_0 = V + jI_d X_d + jI_q X_q$$

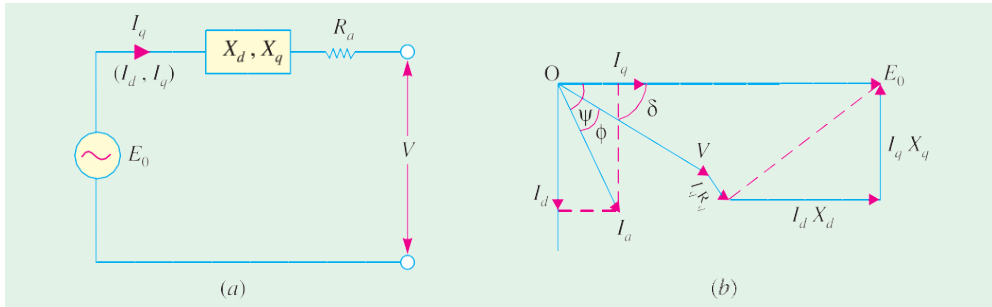

Fig. 37.71

Incidentally, we may also draw the phasor diagram with terminal voltage V lying in the horizontal direction as shown in Fig. 37-72 (b). Here, again drop $I_a R_a$ is $\parallel I_a$ and $I_d X_d$ is \perp to I_d and drop $I_q X_q$ is \perp to I_q as usual.

Calculations from Phasor Diagram

In Fig. 37.73, dotted line AC has been drawn perpendicular to I_a and CB is perpendicular to the phasor for E_0 . The angle $ACB = \psi$ because angle between two lines is the same as between their perpendiculars. It is also seen that

$$I_d = I_a \sin \psi ; I_q = I_a \cos \psi ; \text{ hence, } I_a = I_q / \cos \psi$$

In ΔABC ,

$$BC/AC = \cos \psi \text{ or } AC = BC/\cos \psi = I_q X_q / \cos \psi = I_a X_q$$

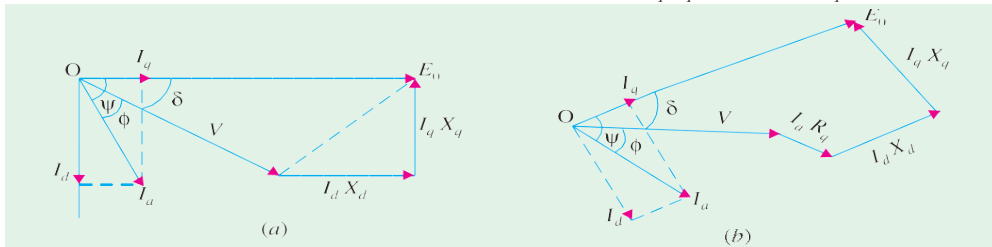

Fig. 37.72

From ΔODC , we get

$$\begin{aligned} \tan \psi &= \frac{AD + AC}{OE + ED} = \frac{V \sin \phi + I_a X_q}{V \cos \phi + I_a R_a} && \text{---generating} \\ &= \frac{V \sin \phi - I_a X_q}{V \sin \phi - I_a R_a} && \text{---motoring} \end{aligned}$$

The angle ψ can be found from the above equation. Then, $\delta = \psi - \phi$ (generating) and $\delta = \phi - \psi$ (motoring)

As seen from Fig. 37.73, the excitation voltage is given by

$$E_0 = V \cos \delta + I_q R_a + I_d X_d \quad \text{---generating}$$

$$= V \cos \delta - I_q R_a - I_d X_d \quad \text{---motoring}$$

Note. Since angle ϕ is taken positive for lagging p.f., it will be taken negative for leading p.f.

If we neglect the armature resistance as shown in Fig. 37.72, then angle δ can be found directly as under :

$$\psi = \phi + \delta \quad (\text{generating})$$

$$\text{and } \psi = \phi - \delta \quad (\text{motoring}).$$

$$\text{In general, } \psi = (\phi \pm \delta).$$

$$I_d = I_a \sin \psi$$

$$= I_a \sin (\phi \pm \delta); I_q = I_a \cos \psi = I_a \cos (\phi \pm \delta)$$

As seen from Fig. 37.73, $V \sin \delta = I_q X_q = I_a X_q \cos (\phi \pm \delta)$

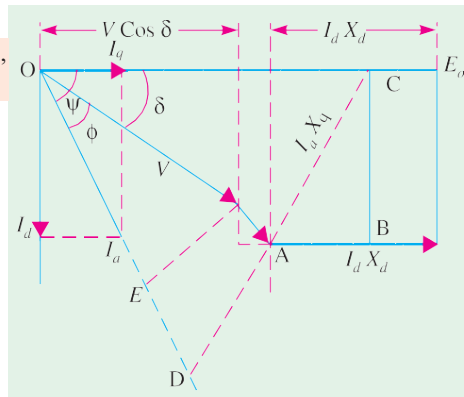

Fig. 37.73

$$\therefore V \sin \delta = I_a X_q (\cos \phi \cos \delta \pm \sin \phi \sin \delta)$$

$$\text{or } V = I_a X_q \cos \phi \cot \delta \pm I_a X_q \sin \phi$$

$$\therefore I_a X_q \cos \phi \cot \delta = V \pm I_a X_q \sin \phi$$

$$\therefore \tan \delta = \frac{I_a X_q \cos \phi}{V \pm I_a X_q \sin \phi}$$

In the above expression, plus sign is for synchronous generators and minus sign for synchronous motors.

Similarly, when R_a is neglected, then,

$$E_0 = V \cos \delta \pm I_d X_d$$

However, if R_a and hence $I_a R_a$ drop is not negligible then,

$$\begin{aligned} E_0 &= V \cos \delta + I_q R_a + I_d X_d && \text{---generating} \\ &= V \cos \delta - I_q R_a - I_d X_d && \text{---motoring} \end{aligned}$$

Power Developed by a synchronous Generator

If we neglect R_a and hence Cu loss, then the power developed (P_d) by an alternator is equal to the power output (P_{out}). Hence, the per phase power output of an alternator is

$$P_{out} = VI_a \cos \phi = \text{power developed } (P_d) \quad \dots(i)$$

$$\text{Now, as seen from Fig., 37.72 (a), } I_q X_q = V \sin \delta; I_d X_d = E_0 - V \cos \delta \quad \dots(ii)$$

$$\text{Also, } I_d = I_a \sin (\phi + \delta); I_q = I_a \cos (\phi + \delta) \quad \dots(iii)$$

Substituting Eqn. (iii) in Eqn. (ii) and solving for $I_a \cos \phi$, we get

$$I_a \cos \phi = \frac{V}{X_d} \sin \delta + \frac{V}{2 X_q} \sin 2 \delta - \frac{V}{2 X_d} \sin 2 \delta$$

Finally, substituting the above in Eqn. (i), we get

$$P_d = \frac{E_0 V}{X_d} \sin \delta + \frac{1}{2} V^2 \left(\frac{1}{X_q} - \frac{1}{X_d} \right) \sin 2 \delta = \frac{E_0 V}{X_d} \sin \delta + \frac{V_d^2 (X_d - X_q)}{2 X_d X_q} \sin 2 \delta$$

The total power developed would be three times the above power.

As seen from the above expression, the power developed consists of two components, the first term represents power due to field excitation and the second term gives the reluctance power *i.e.*

power due to saliency. If $X_d = X_q$ i.e. the machine has a cylindrical rotor, then the second term becomes zero and the power is given by the first term only. If, on the other hand, there is no field excitation i.e. $E_0 = 0$, then the first term in the above expression becomes zero and the power developed is given by the second term. It may be noted that value of δ is positive for a generator and negative for a motor.

Example 37.39. A 3-phase alternator has a direct-axis synchronous reactance of 0.7 p.u. and a quadrature axis synchronous reactance of 0.4 p.u. Draw the vector diagram for full-load 0.8 p.f. lagging and obtain therefrom (i) the load angle and (ii) the no-load per unit voltage.

(Advanced Elect. Machines, AMIE Sec. B 1991)

Solution.

$$V = 1 \text{ p.u.}; X_d = 0.7 \text{ p.u.}; X_q = 0.4 \text{ p.u.};$$

$$\cos \phi = 0.8; \sin \phi = 0.6; \phi = \cos^{-1} 0.8 = 36.9^\circ; I_a = 1 \text{ p.u.}$$

$$(i) \quad \tan \delta = \frac{I_a X_q \cos \phi}{V + I_a \sin \phi} = \frac{1 \times 0.4 \times 0.8}{1 + 0.4 \times 0.6} = 0.258, \delta = 14.9^\circ$$

$$(ii) \quad I_d = I_a \sin(\phi + \delta) = 1 \sin(36.9^\circ + 14.9^\circ) = 0.78 \text{ A}$$

$$E_0 = V \cos \delta + I_d X_d = 1 \times 0.966 + 0.78 \times 0.75 = 1.553$$

Example 37.40. A 3-phase, star-connected, 50-Hz synchronous generator has direct-axis synchronous reactance of 0.6 p.u. and quadrature-axis synchronous reactance of 0.45 p.u. The generator delivers rated kVA at rated voltage. Draw the phasor diagram at full-load 0.8 p.f. lagging and hence calculate the open-circuit voltage and voltage regulation. Resistive drop at full-load is 0.015 p.u.

(Elect. Machines-II, Nagpur Univ. 1993)

Solution.

$$I_a = 1 \text{ p.u.}; V = 1 \text{ p.u.}; X_d = 0.6 \text{ p.u.}; X_q = 0.45 \text{ p.u.}; R_a = 0.015 \text{ p.u.}$$

$$\tan \psi = \frac{V \sin \phi + I_a X_q}{V \cos \phi + I_a R_a} = \frac{1 \times 0.6 + 1 \times 0.45}{1 \times 0.8 + 1 \times 0.015} = 1.288; \quad \psi = 52.2^\circ$$

$$\delta = \psi - \phi = 52.2^\circ - 36.9^\circ = 15.3^\circ$$

$$I_d = I_a \sin \psi = 1 \times 0.79 = 0.79 \text{ A}; I_q = I_a \cos \psi = 1 \times 0.61 = 0.61 \text{ A}$$

$$E_0 = V \cos \delta + I_q R_a + I_d X_d$$

$$= 1 \times 0.965 + 0.61 \times 0.015 + 0.79 \times 0.6 = 1.448$$

$$\therefore \% \text{ regn.} = \frac{1.448 - 1}{1} \times 100 = 44.8\%$$

Example 37.41. A 3-phase, Y-connected syn. generator supplies current of 10 A having phase angle of 20° lagging at 400 V. Find the load angle and the components of armature current I_d and I_q if $X_d = 10 \text{ ohm}$ and $X_q = 6.5 \text{ ohm}$. Assume arm. resistance to be negligible.

(Elect. Machines-I, Nagpur Univ. 1993)

Solution.

$$\cos \phi = \cos 20^\circ = 0.94; \sin \phi = 0.342; I_a = 10 \text{ A}$$

$$\tan \delta = \frac{I_a X_q \cos \phi}{V + I_a X_q \sin \phi} = \frac{10 \times 6.5 \times 0.94}{400 + 10 \times 6.5 \times 0.342} = 0.1447$$

$$\delta = 8.23^\circ$$

$$I_d = I_a \sin(\phi + \delta) = 10 \sin(20^\circ + 8.23^\circ) = 4.73 \text{ A}$$

$$I_q = I_a \cos(\phi + \delta) = 10 \cos(20^\circ + 8.23^\circ) = 8.81 \text{ A}$$

Incidentally, if required, voltage regulation of the above generator can be found as under:

$$I_d X_d = 4.73 \times 10 = 47.3 \text{ V}$$

$$E_0 = V \cos \delta + I_d X_d = 400 \cos 8.23^\circ + 47.3 = 443 \text{ V}$$

$$\begin{aligned}\% \text{ regn.} &= \frac{E_0 - V}{V} \times 100 \\ &= \frac{443 - 400}{400} \times 100 = \mathbf{10.75\%}\end{aligned}$$

Tutorial Problem No. 37.5.

1. A 20 MVA, 3-phase, star-connected, 50-Hz, salient-pole has $X_d = 1$ p.u.; $X_q = 0.65$ p.u. and $R_a = 0.01$ p.u. The generator delivers 15 MW at 0.8 p.f. lagging to an 11-kV, 50-Hz system. What is the load angle and excitation e.m.f. under these conditions? **[18°; 1.73 p.u.]**
2. A salient-pole synchronous generator delivers rated kVA at 0.8 p.f. lagging at rated terminal voltage. It has $X_d = 1.0$ p.u. and $X_q = 0.6$ p.u. If its armature resistance is negligible, compute the excitation voltage under these conditions. **[1.77 p.u.]**
3. A 20-kVA, 220-V, 50-Hz, star-connected, 3-phase salient-pole synchronous generator supplies load at a lagging power factor angle of 45° . The phase constants of the generator are $X_d = 4.0 \Omega$; $X_q = 2 \Omega$ and $R_a = 0.5 \Omega$. Calculate (i) power angle and (ii) voltage regulation under the given load conditions. **[(i) 20.6° (ii) 142%]**
4. A 3-phase salient-pole synchronous generator has $X_d = 0.8$ p.u.; $X_q = 0.5$ p.u. and $R_a = 0$. Generator supplies full-load at 0.8 p.f. lagging at rated terminal voltage. Compute (i) power angle and (ii) no-load voltage if excitation remains constant. **[(i) 17.1° (ii) 1.6 p.u.]**

Parallel Operation of Alternators

The operation of connecting an alternator in parallel with another alternator or with common bus-bars is known as **synchronizing**. Generally, alternators are used in a power system where they are in parallel with many other alternators. It means that the alternator is connected to a live system of constant voltage and constant frequency. Often the electrical system to which the alternator is connected, has already so many alternators and loads connected to it that no matter what power is delivered by the incoming alternator, the voltage and frequency of the system remain the same. In that case, the alternator is said to be connected to **infinite** bus-bars.

It is never advisable to connect a stationary alternator to live bus-bars, because, stator induced e.m.f. being zero, a short-circuit will result. For proper synchronization of alternators, the following three conditions must be satisfied:

1. The terminal voltage (effective) of the incoming alternator must be the same as bus-bar voltage.
2. The speed of the incoming machine must be such that its frequency ($= PN/120$) equals bus-bar frequency.
3. The phase of the alternator voltage must be identical with the phase of the bus-bar voltage. It means that the switch must be closed at (or very near) the instant the two voltages have correct phase relationship.

Condition (1) is indicated by a voltmeter, conditions (2) and (3) are indicated by synchronizing lamps or a synchroscope.

Synchronizing of Alternators

(a) Single-phase Alternators

Suppose machine 2 is to be synchronized with or 'put on' the bus-bars to which machine 1 is already connected. This is done with the help of two lamps L_1 and L_2 (known as synchronizing lamps) connected as shown in Fig. 37.74.

It should be noted that E_1 and E_2 are in-phase relative to the external circuit but are in direct phase opposition in the local circuit (shown dotted).

If the speed of the incoming machine 2 is not brought up to that of machine 1, then its frequency will also be different, hence there will be a phase-difference between their voltages (even when they are equal in magnitude, which is determined by field excitation). This phase-difference will be continuously changing with the changes in their frequencies. The result is that their resultant voltage will undergo changes similar to the frequency changes of beats produced, when two sound sources of nearly equal frequency are sounded together, as shown in Fig. 37.75.

Sometimes the resultant voltage is maximum and some other times minimum. Hence, the current is alternately maximum and minimum. Due to this changing current through the lamps, a flicker will be produced, the frequency of flicker being $(f_2 \sim f_1)$. Lamps will dark out and glow up alternately. Darkness indicates that the two voltages E_1 and E_2 are in exact phase opposition relative to the local circuit and hence

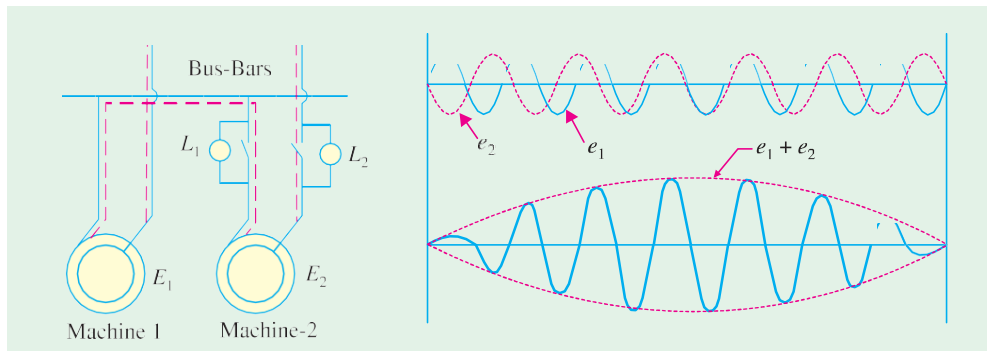

Fig. 37.74

Fig. 37.75

there is no resultant current through the lamps. Synchronizing is done at the middle of the dark period. That is why, sometimes, it is known as ‘lamps dark’ synchronizing. Some engineers prefer ‘lamps bright’ synchronization because of the fact the lamps are much more sensitive to changes in voltage at their maximum brightness than when they are dark. Hence, a sharper and more accurate synchronization is obtained. In that case, the lamps are connected as shown in Fig. 37.76. Now, the lamps will glow brightest when the two voltages are in-phase with the bus-bar voltage because then voltage across them is twice the voltage of each machine.

(b) Three-phase Alternators

In 3- ϕ alternators, it is necessary to synchronize one phase only, the other two phases will then be synchronized automatically. However, first it is necessary that the incoming alternator is correctly ‘phased out’ *i.e.* the phases are connected in the proper order of *R, Y, B* and not *R, B, Y* etc.

In this case, three lamps are used. But they are deliberately connected asymmetrically, as shown in Fig. 37.77 and 37.78.

This transposition of two lamps, suggested by Siemens and Halske, helps to indicate whether the incoming machine is running too slow. If lamps were connected symmetrically, they would dark out or glow up simultaneously (if the phase rotation is the same as that of the bus-bars).

Lamp L_1 is connected between *R* and R' , L_2 between *Y* and B (not *Y* and Y') and L_3 between *B* and Y' (and not *B* and B'), as shown in Fig. 37.78.

Voltage stars of two machines are shown superimposed on each other in Fig. 37.79.

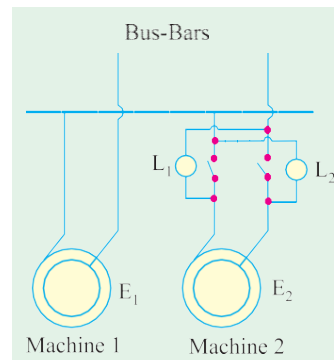

Fig. 37.76

Two sets of star vectors will rotate at unequal speeds if the frequencies of the two machines are different. If the incoming alternator is running faster, then voltage star RYB will appear to rotate anticlockwise with respect to the bus-bar voltage star RYB at a speed corresponding to the difference between their frequencies. With reference to Fig. 37.79, it is seen that voltage across L_1 is RR and is seen to be increasing from zero, that across L_2 is YB which is decreasing, having just passed through its maximum, that across L_3 is BY which is increasing and approaching its maximum. Hence, the lamps will light up one after the other in the order 2, 3, 1 ; 2, 3, 1 or 1, 2, 3.



The rotor and stator of 3-phase generator

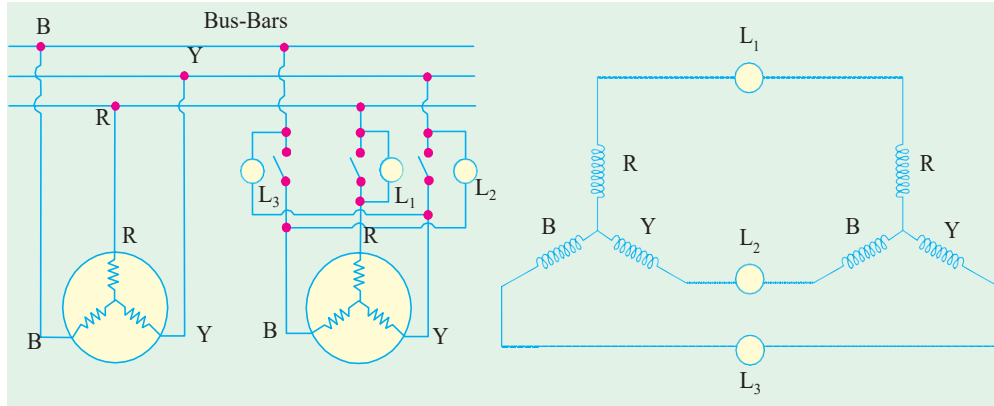

Fig. 37.77

Fig. 37.78

Now, suppose that the incoming machine is slightly slower. Then the star RYB will appear to be rotating clockwise relative to voltage star RYB (Fig. 37.80). Here, we find that voltage across L_3 i.e. YB is decreasing having just passed through its maximum, that across L_2 i.e. YB is increasing and approaching its maximum, that across L_1 is decreasing having passed through its maximum earlier. Hence, the lamps will light up one after the other in the order 3, 2, 1 ; 3, 2, 1, etc. which is just the reverse of the first order. Usually, the three lamps are mounted at the three corners of a triangle and the apparent direction of rotation of light

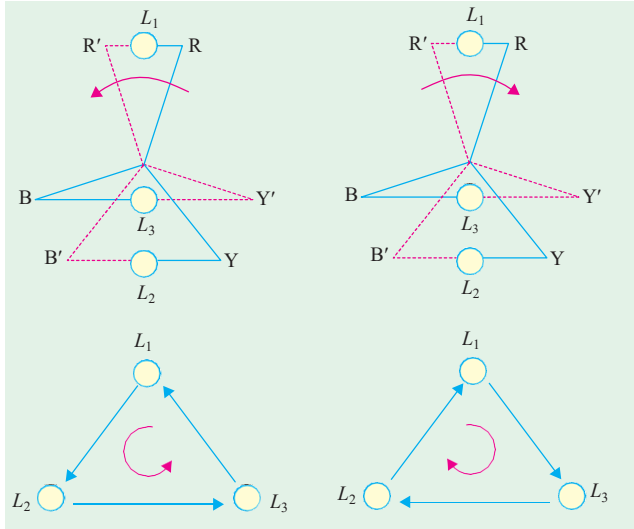

Fig. 37.79

Fig. 37.80

indicates whether the incoming alternator is running too fast or too slow (Fig. 37.81). Synchronization is done at the moment the uncrossed lamp L_1 is in the middle of the dark period. When the alternator voltage is too high for the lamps to be used directly, then usually step-down transformers are used and the synchronizing lamps are connected to the secondaries.

It will be noted that when the uncrossed lamp L_1 is dark, the other two ‘crossed’ lamps L_2 and L_3 are dimly but equally bright. Hence, this method of synchronizing is also sometimes known as ‘two bright and one dark’ method.

It should be noted that synchronization by lamps is not quite accurate, because to a large extent, it depends on the sense of correct judgement of the operator. Hence, to eliminate the element of personal judgment in routine operation of alternators, the machines are synchronized by a more accurate device called a synchronoscope. It consists of 3 stationary coils and a rotating iron vane which is attached to a pointer. Out of three coils, a pair is connected to one phase of the line and the other to the corresponding machine terminals, potential transformer being usually used. The pointer moves to one side or the other from its vertical position depending on whether the incoming machine is too fast or too slow. For correct speed, the pointer points vertically up.

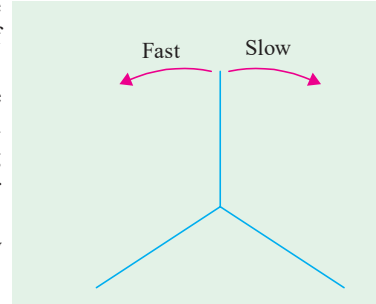

Fig. 37.81

Example 37.42. In Fig. 37.74, $E_1 = 220\text{ V}$ and $f_1 = 60\text{ Hz}$, whereas $E_2 = 222\text{ V}$ and $f_2 = 59\text{ Hz}$. With the switch open; calculate

- (i) maximum and minimum voltage across each lamp.
- (ii) frequency of voltage across the lamps.
- (iii) peak value of voltage across each lamp.
- (iv) phase relations at the instants maximum and minimum voltages occur.
- (v) the number of maximum light pulsations/minute.

Solution. (i) $E_{\max}/\text{lamp} = (220 + 222)/2 = 221\text{ V}$

$E_{\min}/\text{lamp} = (222 - 220)/2 = 1.0\text{ V}$

(ii) $f = (f_1 - f_2) = (60 - 59) = 1.0\text{ Hz}$

(iii) $E_{\text{peak}} = 221/0.707 = 313\text{ V}$

(iv) in-phase and anti-phase respectively in the local circuit.

(v) No. of pulsation/min = $(60 - 59) \times 60 = 60$.

Synchronizing Current

Once synchronized properly, two alternators continue to run in synchronism. Any tendency on the part of one to drop out of synchronism is immediately counteracted by the production of a synchronizing torque, which brings it back to synchronism.

When in exact synchronism, the two alternators have equal terminal p.d.'s and are in exact phase opposition, so far as the local circuit (consisting of their armatures) is concerned. Hence, there is no current circulating round the local circuit. As shown in Fig. 37.82 (b) e.m.f. E_1 of machine No. 1 is in exact phase opposition to the e.m.f. of machine No. 2 i.e. E_2 . It should be clearly understood that the two e.m.f.s. are in opposition, so far as their local circuit is concerned but are in the same direction with respect to the external circuit. Hence, there is no resultant voltage (assuming $E_1 = E_2$ in magnitude) round the local circuit.

But now suppose that due to change in the speed of the governor of second machine, E_2 falls back* by a phase angle of α electrical degrees, as shown in Fig. 37.82 (c) (though still $E_1 = E_2$). Now, they have a resultant voltage E_r , which when acting on the local circuit, circulates a current known as synchronizing current. The value of this current is given by $I_{SY} = E_r / Z_S$ where Z_S is the synchronous impedance of the phase windings of both the machines (or of one machine only if it is connected to infinite bus-bars**). The current I_{SY} lags behind E_r by an angle θ given by $\tan \theta = X_S / R_a$ where X_S is the combined synchronous reactance of the two machines and R_a their armature resistance. Since R_a is negligibly small, θ is almost 90 degrees. So I_{SY} lags E_r by 90° and is almost in phase with E_1 . It is seen that I_{SY} is generating current with respect to machine No. 1 and motoring current with respect to machine No. 2 (remember when the current flows in the same direction as e.m.f., then the alternator acts as a generator, and when it flows in the opposite direction, the machine acts as a motor). This current I_{SY} sets up a synchronising torque, which tends to retard the generating machine (*i.e.* No. 1) and accelerate the motoring machine (*i.e.* No. 2).

Similarly, if E_2 tends to advance in phase [Fig. 37.82 (d)], then I_{SY} , being generating current for machine No. 2, tends to retard it and being motoring current for machine No. 1 tends to accelerate it. Hence, any departure from synchronism results in the production of a synchronizing current I_{SY} which sets up synchronizing torque. This re-establishes synchronism between the two machines by retarding the leading machine and by accelerating the lagging one. This current I_{SY} , it should be noted, is superimposed on the load currents in case the machines are loaded.

Synchronizing Power

Consider Fig. 37.82 (c) where machine No. 1 is generating and supplying the synchronizing power = $E_1 I_{SY} \cos \phi_1$ which is approximately equal to $E_1 I_{SY}$ (ϕ_1 is small). Since $\phi_1 = (90^\circ - \theta)$, synchronizing power = $E_1 I_{SY} \cos \phi_1 = E_1 I_{SY} \cos (90^\circ - \theta) = E_1 I_{SY} \sin \theta \cong E_1 I_{SY}$ because $\theta \cong 90^\circ$ so that

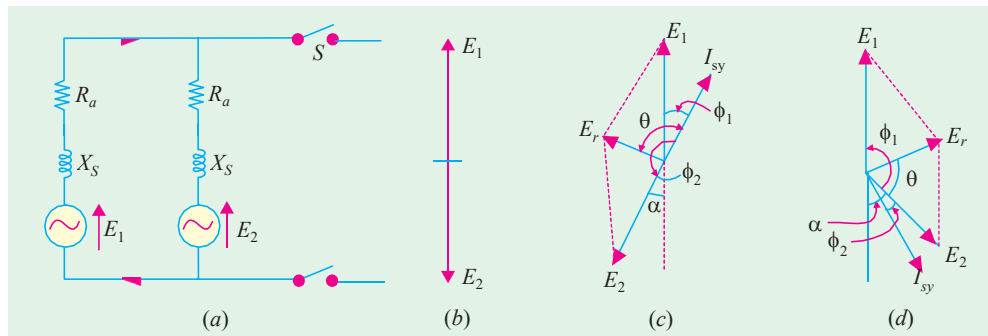

Fig. 37.82

$\sin \theta \cong 1$. This power output from machine No. 1 goes to supply (a) power input to machine No. 2 (which is motoring) and (b) the Cu losses in the local armature circuit of the two machines. Power input to machine No. 2 is $E_2 I_{SY} \cos \phi_2$ which is approximately equal to $E_2 I_{SY}$.

$$\therefore E_1 I_{SY} = E_2 I_{SY} + \text{Cu losses}$$

Now, let $E_1 = E_2 = E$ (say)

Then, $E_r = 2 E \cos [(180^\circ - \alpha)/2]^{***} = 2E \cos [90^\circ - (\alpha/2)]$

* Please remember that vectors are supposed to be rotating anticlockwise.

** Infinite bus-bars are those whose frequency and the phase of p.d.'s are not affected by changes in the conditions of any one machine connected in parallel to it. In other words, they are constant-frequency, constant-voltage bus-bars.

*** Strictly speaking, $E_r = 2E \sin \theta$. $\sin \alpha/2 \cong 2E \sin \alpha/2$.

$$= 2 E \sin \alpha/2 = 2 E \times \alpha/2 = \alpha E \quad (\because \alpha \text{ is small})$$

Here, the angle α is in electrical radians.

Now,
$$I_{SY} = \frac{E_r}{\text{synch. impedance } Z_S} \cong \frac{E_r}{2 X_S} = \frac{\alpha E}{2 X_S}$$
 —if R_a of both machines is negligible

Here, X_S represents synchronous reactance of one machine and not of both as in Art. 37.31 Synchronizing power (supplied by machine No. 1) is

$$P_{SY} = E_1 I_{SY} \cos \phi_1 = E I_{SY} \cos (90^\circ - \theta) = E I_{SY} \sin \theta \cong E I_{SY}$$

Substituting the value of I_{SY} from above,

$$P_{SY} = E \cdot \alpha E / 2 X_S = \alpha E^2 / 2 X_S \cong \alpha E^2 / 2 X_S \quad \text{—per phase}$$

(more accurately, $P_{SY} = \alpha E^2 \sin \theta / 2 X_S$)

Total synchronizing power for three phases

$$= 3 P_{SY} = 3 \alpha E^2 / 2 X_S \quad (\text{or } 3 \alpha E^2 \sin \theta / 2 X_S)$$

This is the value of the synchronizing power when two alternators are connected in parallel and are on no-load.

Alternators Connected to Infinite Bus-bars

Now, consider the case of an alternator which is connected to infinite bus-bars. The expression for P_{SY} given above is still applicable but with one important difference *i.e.* impedance (or reactance) of only that one alternator is considered (and not of two as done above). Hence, expression for synchronizing power in this case becomes

$$E_r = \alpha E \quad \text{—as before}$$

$$I_{SY} = E_r / Z_S \cong E_r / X_S = \alpha E / X_S \quad \text{—if } R_a \text{ is negligible}$$

$$\therefore \text{Synchronizing power } P_{SY} = E I_{SY} = E \cdot \alpha E / X_S = \alpha E^2 / X_S \quad \text{— per phase}$$

Now, $E / X_S \cong E / X_S = \text{S.C. current } I_{SC}$

$$\therefore P_{SY} = \alpha E / X_S = \alpha E \cdot E / X_S = \alpha E \cdot I_{SC} \quad \text{—per phase}$$

(more accurately, $P_{SY} = \alpha E^2 \sin \theta / X_S = \alpha E \cdot I_{SC} \cdot \sin \theta$)

Total synchronizing power for three phases = $3 P_{SY}$

Synchronizing Torque T_{SY}

Let T_{SY} be the synchronizing torque per phase in newton-metre (N-m)

(a) When there are two alternators in parallel

$$\therefore T_{SY} \times \frac{2 \pi N_S}{60} = P_{SY} \therefore T_{SY} = \frac{P_{SY}}{2 \pi N_S / 60} = \frac{\alpha E^2 / 2 X_S}{2 \pi N_S / 60} \text{ N-m}$$

$$\text{Total torque due to three phases.} = \frac{3 P_{SY}}{2 \pi N_S / 60} = \frac{3 \alpha E^2 / 2 X_S}{2 \pi N_S / 60} \text{ N-m}$$

(b) Alternator connected to infinite bus-bars

$$T_{SY} \times \frac{2 \pi N_S}{60} = P_{SY} \quad \text{or} \quad T_{SY} = \frac{P_{SY}}{2 \pi N_S / 60} = \frac{\alpha E^2 / X_S}{2 \pi N_S / 60} \text{ N-m}$$

$$\text{Again, torque due to 3 phase} = \frac{3 P_{SY}}{2 \pi N_S / 60} = \frac{3 \alpha E^2 / X_S}{2 \pi N_S / 60} \text{ N-m}$$

where $N_S =$ synchronous speed in r.p.m. = $120 / f P$

Effect of Load on Synchronizing Power

In this case, instead of $P_{SY} = \alpha \frac{E^2}{X_S}$ the approximate value of synchronizing power would be $\cong \alpha EV/X_S$ where V is bus-bar voltage and E is the alternator induced e.m.f. per phase. The value of $E = V + IZ_S$

As seen from Fig. 37.83, for a lagging p.f.,
 $E = (V \cos \phi + IR_a)^2 + (V \sin \phi + IX_S)^2)^{1/2}$

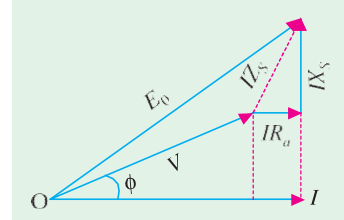

Fig. 37.83

Example 37.43. Find the power angle when a 1500-kVA, 6.6 kV, 3-phase, Y-connected alternator having a resistance of 0.4 ohm and a reactance of 6 ohm per phase delivers full-load current at normal rated voltage and 0.8 p.f. lag. Draw the phasor diagram.

(Electrical Machinery-II, Bangalore Univ. 1981)

Solution. It should be remembered that angle α between V and E is known as power angle (Fig. 37.84)

Full-load $I = 15 \times 10^5 / 3 \sqrt{3} \times 6600 = 131 \text{ A}$
 $IR_a = 131 \times 0.4 = 52.4 \text{ V}, IX_S = 131 \times 6 = 786 \text{ V}$

V/phase $= 6600 / \sqrt{3} = 3810 \text{ V};$
 $\phi = \cos^{-1}(0.8) = 36^\circ 50'$

As seen from Fig. 37.84

$$\tan(\phi + \alpha) = \frac{AB}{OA} = \frac{V \sin \phi + IX_S}{V \cos \phi + IR_a}$$

$$= \frac{3810 \times 0.6 + 786}{3810 \times 0.8 + 52.4} = 0.991$$

$\therefore (\phi + \alpha) = 44^\circ \therefore \alpha = 44^\circ - 36^\circ 50' = 7^\circ 10'$

The angle α is also known as load angle or torque angle.

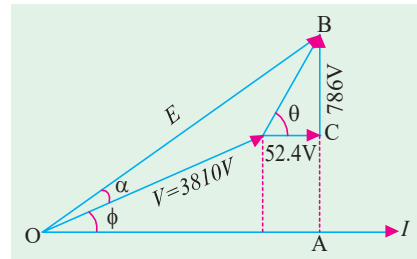

Fig. 37.84

Alternative Expression for Synchronizing Power

As shown in Fig. 37.85, let V and E (or E_0) be the terminal voltage and induced e.m.f. per phase of the rotor. Then, taking $V = V \angle 0^\circ$, the load current supplied by the alternator is

$$I = \frac{E - V}{Z_S} = \frac{E \angle \alpha - V \angle 0^\circ}{Z_S}$$

$$= \frac{E}{Z_S} \angle \alpha - \frac{V}{Z_S} \angle -\theta$$

$$= \frac{E}{Z_S} [\cos(\theta - \alpha) - j \sin(\theta - \alpha)]$$

$$= -\frac{V}{Z_S} (\cos \theta - j \sin \theta)$$

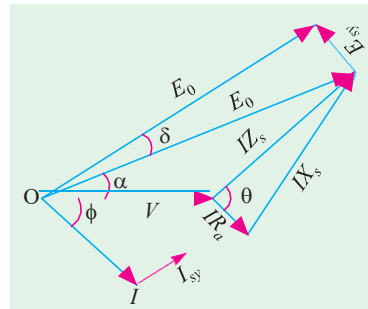

Fig. 37.85

These components represent the $I \cos \phi$ and $I \sin \phi$ respectively. The power P converted internally is given by the sum of the product of corresponding components of the current with $E \cos \alpha$ and $E \sin \alpha$.

$$\begin{aligned} \therefore P &= E \cos \alpha \left[\frac{E}{Z} \cos (\theta - \alpha) - \frac{V}{Z} \cos \theta \right] - E \sin \alpha \left[\frac{E}{Z_S} \sin (\theta - \alpha) - \frac{V}{Z_S} \sin \theta \right] \\ &= E \left[\frac{E \cos \theta}{Z_S} - E \frac{V}{Z_S} \cos (\theta + \alpha) \right] = \frac{E}{Z_S} [E \cos \theta - V (\cos \theta + \alpha)] \quad \text{—per phase*} \end{aligned}$$

Now, let, for some reason, angle α be changed to $(\alpha \pm \delta)$. Since V is held rigidly constant, due to displacement $\pm \delta$, an additional e.m.f. of divergence *i.e.* $I_{SY} = 2E \cdot \sin \alpha/2$ will be produced, which will set up an additional current I_{SY} given by $I_{SY} = E_{SY}/Z_S$. The internal power will become

$$P' = \frac{E}{Z_S} [E \cos \theta - V \cos (\theta + \alpha \pm \delta)]$$

The difference between P' and P gives the synchronizing power.

$$\begin{aligned} \therefore P_{SY} &= P' - P = \frac{EV}{Z_S} [\cos (\theta + \alpha) - \cos (\theta + \alpha \pm \delta)] \\ &= \frac{EV}{Z_S} [\sin \delta \cdot \sin (\theta + \alpha) \pm 2 \cos (\theta + \alpha) \sin^2 \delta/2] \end{aligned}$$

If δ is very small, then $\sin (\delta/2)$ is zero, hence P_{SY} per phase is

$$P_{SY} = \frac{EV}{Z_S} \cdot \sin (\theta + \alpha) \sin \delta \quad \dots(i)$$

(i) In large alternators, R_a is negligible, hence $\tan \theta = X_S/R_a = \infty$, so that $\theta \cong 90^\circ$. Therefore, $\sin (\theta + \alpha) = \cos \alpha$.

$$\therefore P_{SY} = \frac{EV}{Z_S} \cdot \cos \alpha \sin \delta \quad \text{— per phase} \quad \dots(ii)$$

$$= \frac{EV}{X_S} \cos \alpha \sin \delta \quad \text{—per phase} \quad \dots(iii)$$

(ii) Consider the case of synchronizing an unloaded machine on to a constant-voltage bus-bars. For proper operation, $\alpha = 0$ so that E coincides with V . In that case, $\sin (\theta + \alpha) = \sin \theta$.

$$\therefore P_{SY} = \frac{EV}{Z_S} \sin \theta \sin \delta \quad \text{—from (i) above.}$$

$$\therefore P = \frac{EV}{Z_S} \delta \sin \theta = \frac{EV}{Z_S} \delta \sin \theta \quad \text{Since } \delta \text{ is very small, } \sin \delta = \delta, \text{ Usually, } \sin \theta \cong 1, \text{ hence}$$

$$\therefore P_{SY} = \frac{EV}{Z_S} \delta = V \left(\frac{E}{Z_S} \right) \delta = V \left(\frac{E}{X_S} \right) \delta = VI_{SC} \cdot \delta \quad \text{—per phase}$$

Parallel Operation of Two Alternators

Consider two alternators with identical speed/load characteristics connected in parallel as shown in Fig. 37.86. The common terminal voltage V is given by

$$V = E_1 - I_1 Z_1 = E_2 - I_2 Z_2$$

$$\therefore E_1 - E_2 = I_1 Z_1 - I_2 Z_2$$

Also $I = I_1 + I_2$ and $V = IZ$

$$\therefore E_1 = I_1 Z_1 + IZ = I_1(Z + Z_1) + I_2 Z$$

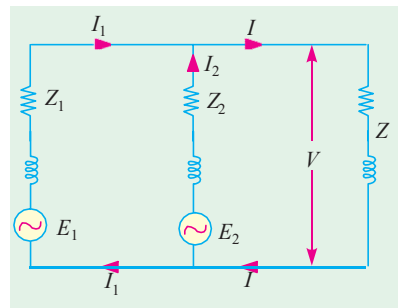

Fig. 37.86

* In large machines, R_a is very small so that $\theta = 90^\circ$, hence $P = \frac{E}{Z_S} V \cos(90^\circ \alpha) = \frac{E}{Z_S} V \sin \alpha = \alpha EV / Z_S$
 —if α is so small that $\sin \alpha = \alpha$

** With $E = V$, the expression becomes $P_{SY} = \frac{V^2}{Z_S} \delta = X_S$ It is the same as in Art. 37.33 —per phase

$$E_2 = I_2 Z_2 + IZ = I_2(Z + Z_2) + I_1 Z$$

$$\therefore I_1 = \frac{(E_1 - E_2) Z + E_1 Z_2}{Z(Z_1 + Z_2) + Z_1 Z_2}$$

$$I_2 = \frac{(E_2 - E_1) Z + E_2 Z_1}{Z(Z_1 + Z_2) + Z_1 Z_2};$$

$$\frac{E_1 Z_2 + E_2 Z_1}{Z_1 Z_2 + E_2 Z_1}$$

$$I = \frac{Z(Z_1 + Z_2) + Z_1 Z_2}{Z_1 + Z_2 + (Z_1 Z_2 / Z)}; I = \frac{E_1 - V}{Z_1}; I = \frac{E_2 - V}{Z_2}$$

The circulating current under no-load condition is $I_C = (E_1 - E_2)/(Z_1 + Z_2)$.

Using Admittances

The terminal Voltage may also be expressed in terms of admittances as shown below:

$$V = IZ = (I_1 + I_2)Z \quad \therefore I_1 + I_2 = V/Z = VY \quad \dots(i)$$

Also $I_1 = (E_1 - V)/Z_1 = (E_1 - V)Y_1; \quad I_2 = (E_2 - V)/Z_2 = (E_2 - V)Y_2$

$$\therefore I_1 + I_2 = (E_1 - V)Y_1 + (E_2 - V)Y_2 \quad \dots(ii)$$

From Eq. (i) and (ii), we get

$$VY = (E_1 - V)Y_1 + (E_2 - V)Y_2 \quad \text{or} \quad V = \frac{E_1 Y_1 + E_2 Y_2}{Y_1 + Y_2 + Y}$$

Using Parallel Generator Theorem

$$V = IZ = (I_1 + I_2)Z = \left(\frac{E_1 - V}{Z_1} + \frac{E_2 - V}{Z_2} \right) Z$$

$$= \left(\frac{E_1}{Z_1} + \frac{E_2}{Z_2} \right) Z - V \left(\frac{1}{Z_1} + \frac{1}{Z_2} \right) Z$$

$$\therefore V \left(\frac{1}{Z} + \frac{1}{Z_1} + \frac{1}{Z_2} \right) = \frac{E_1}{Z_1} + \frac{E_2}{Z_2} = I_{SC1} + I_{SC2} = I_{SC}$$

where I_{SC1} and I_{SC2} are the short-circuit currents of the two alternators.

If $\frac{1}{Z_0} = \left(\frac{1}{Z} + \frac{1}{Z_1} + \frac{1}{Z_2} \right);$ then $V \times \frac{1}{Z_0} = I_{SC} \quad \text{or} \quad V = Z_0 I_{SC}$

Example 37.44. A 3,000-kVA, 6-pole alternator runs at 1000 r.p.m. in parallel with other machines on 3,300-V bus-bars. The synchronous reactance is 25%. Calculate the synchronizing power for one mechanical degree of displacement and the corresponding synchronizing torque.

(Elect. Machines-I, Gwalior Univ. 1984)

Solution. It may please be noted that here the alternator is working in parallel with many alternators. Hence, it may be considered to be connected to infinite bus-bars.

$$\text{Voltage/phase} = 3,300 / \sqrt{3} = 1905 \text{ V}$$

F.L. current $I = 3 \times 10^6 / \sqrt{3} \times 3300 = 525 \text{ A}$

Now, $I X_S = 25\% \text{ of } 1905 \quad \therefore X_S = 0.25 \times 1905 / 525 = 0.9075 \Omega$

Also, $P_{SY} = 3 \times \alpha E / X_S^2$

Here $\alpha = 1^\circ \text{ (mech.); } \alpha \text{ (elect.)} = 1 \times (6/2) = 3^\circ$

$\therefore \alpha = 3 \times \pi / 180 = \pi / 60 \text{ elect. radian.}$

$$\therefore P_{SY} = \frac{3 \times \pi \times 1905^2}{60 \times 0.9075 \times 1000} = 628.4 \text{ kW}$$

$$T_{SY} = \frac{60 \cdot P_S}{2\pi N_s} = 9.55 \frac{P_{SY}}{N} = 9.55 \frac{628.4 \times 10^3}{1000} = 6,000 \text{ N-m}$$

Example 37.45. A 3-MVA, 6-pole alternator runs at 1000 r.p.m on 3.3-kV bus-bars. The synchronous reactance is 25 percent. Calculate the synchronising power and torque per mechanical degree of displacement when the alternator is supplying full-load at 0.8 lag.

(Electrical Machines-1, Bombay Univ. 1987)

Solution. $V = 3,300/\sqrt{3} = 1905 \text{ V/phase}$, F.L. $I = 3 \times 10^6/\sqrt{3} \times 3,300 = 525 \text{ A}$

$$IX_S = 25\% \text{ of } 1905 = 476 \text{ V}; X_S = 476/525 = 0.9075 \Omega$$

Let, $I = 525 \angle 0^\circ$, then, $V = 1905 (0.8 + j0.6) = 1524 + j1143$

$$E_0 = V + IX_S = (1524 + j1143) + (0 + j476) = (1524 + j1619) = 2220 \angle 46^\circ 44'$$

Obviously, E_0 leads I by $46^\circ 44'$. However, V leads I by $\cos^{-1}(0.8) = 36^\circ 50'$.

Hence, $\alpha = 46^\circ 44' - 36^\circ 50' = 9^\circ 54'$

$$\alpha = 1^\circ \text{ (mech.)}, \text{ No. of pair of poles} = 6/2 = 3 \quad \therefore \alpha = 1 \times 3 = 3^\circ \text{ (elect.)}$$

$$P_{SY} \text{ per phase} = \frac{EV}{X_S} \cos \alpha \sin \delta = \frac{2220 \times 1905}{0.9075} \times \cos 9^\circ 54' \sin 3^\circ \approx 218 \text{ kW}$$

P_{SY} for three phases = $3 \times 218 = 654 \text{ kW}$

$$T_{SY} = 9.55 \times P_{SY}/N_S = 9.55 \times 654 \times 10^2/1000 = 6245 \text{ N-m}$$

Example 37.46. A 750-kVA, 11-kV, 4-pole, 3- ϕ , star-connected alternator has percentage resistance and reactance of 1 and 15 respectively. Calculate the synchronising power per mechanical degree of displacement at (a) no-load (b) at full-load 0.8 p.f. lag. The terminal voltage in each case is 11 kV.

(Electrical Machines-II, Indore Univ. 1985)

Solution. F.L. Current $I = 75 \times 10^3/\sqrt{3} \times 11 \times 10^3 = 40 \text{ A}$

$$V_{ph} = 11,000/3 \sqrt{3} = 6,350 \text{ V}, IR_a = 1\% \text{ of } 6,350 = 63.5$$

or $40 R_a = 63.5, R_a = 1.6 \Omega; 40 \times X_S = 15\% \text{ of } 6,350 = 952.5 \text{ V}$

$$\therefore X_S = 23.8 \Omega; Z_S = \sqrt{1.6^2 + 23.8^2} \approx 23.8 \Omega$$

(a) No-load

$$\alpha \text{ (mech)} = 1^\circ : \alpha \text{ (elect)} = 1 \times (4/2) = 2^\circ$$

$$= 2 \times \pi/180 = \pi/90 \text{ elect. radian.}$$

$$P_{SY} = \frac{\alpha E^2}{Z_S} \approx \frac{\alpha E^2}{X_S} = \frac{(\pi/90) \times 6350^2}{23.8}$$

$$= 59,140 \text{ W} = 59.14 \text{ kW/phase.}$$

On no-load, V has been taken to be equal to E .

(b) F.L. 0.8 p.f.

As indicated in Art. 37.35, $P_{SY} = \alpha EV/X_S$. The value of E (or E_0) can be found from Fig. 37.87.

$$E = [(V \cos \phi + IR_a)^2 + (V \sin \phi + IX_S)^2]^{1/2}$$

$$= [(6350 \times 0.8 + 63.5)^2 + (6350 \times 0.6 + 952.5)^2]^{1/2} = 7010 \text{ V}$$

$$P_{SY} = \frac{\alpha EV}{X_S} = \frac{(\pi/90) \times 7010 \times 6350}{23.8} = 65,290 \text{ W}$$

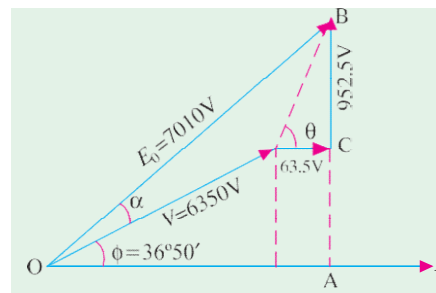

Fig. 37.87

= 65.29 kW/phase

More Accurate Method [Art. 37.35]

$$P_{SY} = \frac{EV}{X_S} \cos \alpha \sin \delta$$

Now, $E = 7010 \text{ V}, V = 6350 \text{ V}, \delta = 1^\circ \times (4/2) = 2^\circ$ (elect)

As seen from Fig. 37.87, $\sin(\phi + \alpha) = AB/OB = (6350 \times 0.6 + 952.5)/7010 = 0.6794$

$$\therefore (\phi + \alpha) = 42^\circ 30'; \alpha = 42^\circ 30' - 36^\circ 50' = 5^\circ 40'$$

$$\therefore P_{SY} = \frac{7010 \times 6350}{23.8} \times \cos 5^\circ 40' \times \sin 2^\circ$$

$$= 7010 \times 6350 \times 0.9953 \times 0.0349/23.8 = 64,970 \text{ W} = \mathbf{64.97 \text{ kW/phase}}$$

Note. It would be instructive to link this example with Ex. 38.1 since both are concerned with synchronous machines, one generating and the other motoring.

Example 37.47. A 2,000-kVA, 3-phase, 8-pole alternator runs at 750 r.p.m. in parallel with other machines on 6,000 V bus-bars. Find synchronizing power on full-load 0.8 p.f. lagging per mechanical degree of displacement and the corresponding synchronizing torque. The synchronous reactance is 6 ohm per phase. (Elect. Machines-II, Bombay Univ. 1987)

Solution. Approximate Method

As seen from Art. 37.37 and 38, $P_{SY} = \alpha EV/X_S$ —per phase

Now $\alpha = 1^\circ$ (mech); No. of pair of poles = $8/2 = 4$;

$$\alpha = 1 \times 4 = 4^\circ \text{ (elect)}$$

$$= 4\pi/180 = \pi/45 \text{ elect. radian}$$

$$V = 6000 / \sqrt{3} = 3,465 \text{ —assuming Y-connection}$$

$$\text{F.L. current } I = 2000 \times 10^3 / \sqrt{3} \times 6000 = 192.4 \text{ A}$$

As seen from Fig. 37.88,

$$E_0 = [(V \cos \phi)^2 + (V \sin \phi + IX_S)^2]^{1/2} = 4295 \text{ V}$$

$$= [(3465 \times 0.8)^2 + (3465 \times 0.6 + 192.4 \times 6)^2]^{1/2}$$

$$= 4295 \text{ V}$$

$$P_{SY} = (\pi/45) \times 4295 \times 3465/6 = 173,160 \text{ W}$$

$$= \mathbf{173.16 \text{ kW/phase}}$$

$$P_{SY} \text{ for three phases} = 3 \times 173.16 = 519.5 \text{ kW}$$

If T_{SY} is the total synchronizing torque for three phases in N-m, then

$$T_{SY} = 9.55 P_{SY}/N_S = 9.55 \times 519,500/750 = \mathbf{6,614 \text{ N-m}}$$

Exact Method

As shown in the vector diagram of Fig. 37.89, I is full-load current lagging V by $\phi = \cos^{-1}(0.8) = 36^\circ 50'$.

The reactance drop is IX_S and its vector is at right angles to (lag.)*. The phase angle between E_0 and V is α .

$$\text{F.L. current } I = 2,000,000 / \sqrt{3} \times 6,000$$

$$= 192.4 \text{ A}$$

$$\text{Let, } I = 192.4 \angle 0^\circ$$

$$V = 3,465 (0.8 + j 0.6) = 2,772 + j 2,079$$

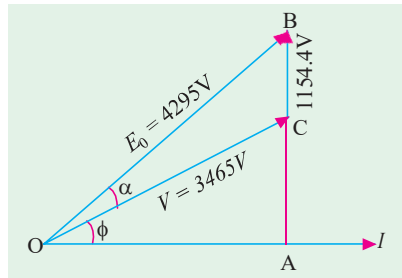

Fig. 37.88

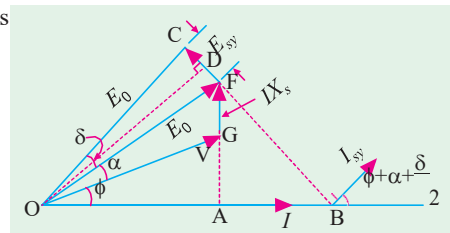

Fig. 37.89

* Earlier, we had called this e.m.f. as E when discussing regulation.

$$IX_S = 192.4 \times 6 = 1154 \text{ V} = (0 + j 1154) \text{ V}$$

$$\begin{aligned} E_0 &= \mathbf{V} + \mathbf{IX}_S \\ &= (2,772 + j 2,079) + (0 + j 1154) \\ &= 2,772 + j 3,233 = 4,259 \angle 49^\circ 24' \\ \alpha &= 49^\circ 24' - 36^\circ 50' = 12^\circ 34' \end{aligned}$$

$$\begin{aligned} E_{SY} &= 2E_0 \sin \delta/2 = 2E_0 \sin(4^\circ/2) \\ &= 2 \times 4,259 \times 0.0349 = 297.3 \text{ V} \end{aligned}$$

$$I_{SY} = 297.3/6 = 49.55 \text{ A}$$

As seen, V leads I by ϕ and I_{SY} leads I by $(\phi + \alpha + \delta/2)$, hence I_{SY} leads V by $(\alpha + \delta/2) = 12^\circ 34' + (4^\circ/2) = 14^\circ 34'$

$$\therefore P_{SY}/\text{phase} = VI_{SY} \cos 14^\circ 34' = 3465 \times 49.55 \times \cos 14^\circ 34' = 166,200 \text{ W} = 166.2 \text{ kW}$$

Synchronising power for three phases is $= 3 \times 166.2 = \mathbf{498.6 \text{ kW}}$

If T_{SY} is the total synchronizing torque, then $T_{SY} \times 2\pi \times 750/60 = 498,600$

$$\therefore T_{SY} = 9.55 \times 498,600/750 = \mathbf{6,348 \text{ N-m}}$$

Alternative Method

We may use Eq. (iii) of Art. 37.36 to find the total synchronizing power.

$$P_{SY} = \frac{EV}{X_s} \cos \alpha \sin \delta \quad \text{---per phase}$$

Here, $E = 4,259 \text{ V}$; $V = 3,465 \text{ V}$; $\alpha = 12^\circ 34'$; $\delta = 4^\circ$ (elect.)

$$\begin{aligned} \therefore P_{SY}/\text{phase} &= 4,259 \times 3,465 \cos 12^\circ 34' \sin 4^\circ/6 \\ &= 4,259 \times 3,465 \times 0.976 \times 0.0698/6 = 167,500 \text{ W} = 167.5 \text{ kW} \end{aligned}$$

$$P_{SY} \text{ for 3 phases} = 3 \times 167.5 = \mathbf{502.5 \text{ kW}}$$

Next, T_{SY} may be found as above.

Example 37.48. A 5,000-kVA, 10,000 V, 1500-r.p.m., 50-Hz alternator runs in parallel with other machines. Its synchronous reactance is 20%. Find for (a) no-load (b) full-load at power factor 0.8 lagging, synchronizing power per unit mechanical angle of phase displacement and calculate the synchronizing torque, if the mechanical displacement is 0.5° .

(Elect. Engg. V, M.S. Univ. Baroda, 1986)

Solution. Voltage /phase $= 10,000 / \sqrt{3} = 5,775 \text{ V}$

Full-load current $= 5,000,000 / \sqrt{3} \times 10,000 = 288.7 \text{ A}$

$$X_S = \frac{20}{100} \times \frac{5,775}{288.7} = 4 \Omega, P = \frac{120f}{N_S} = \frac{120 \times 50}{1500} = 4$$

$\alpha = 1^\circ$ (mech.); No. of pair of poles = 2 $\therefore \alpha = 1 \times 2 = 2^\circ$ (elect.) $= 2\pi/180 = \pi/90$ radian

(a) At no-load

$$P_{SY} = \frac{3 \alpha E^2}{X_S} = 3 \times \frac{\pi}{90} \times \frac{5,775^2}{4 \times 1000} = \mathbf{873.4 \text{ kW}}$$

$$\therefore T_{SY} = 9.55 \times (873.4 \times 10^3)/1500 = 5,564 \text{ N-m}$$

$$\therefore T_{SY} \text{ for } 0.5^\circ = 5564/2 = \mathbf{2,782 \text{ N-m}}$$

(b) At F.L. p.f. 0.8 lagging

Let $\mathbf{I} = 288.7 \angle 0^\circ$. Then $\mathbf{V} = 5775 (0.8 + j 0.6) = 4620 + j 3465$

$$\mathbf{IX}_S = 288.7 \angle 0^\circ \times 4 \angle 90^\circ = (0 + j 1155)$$

$$\mathbf{E}_0 = \mathbf{V} + \mathbf{IX}_S = (4620 + j 3465) + (0 + j 1155)$$

$$= 4620 + j4620 = 6533 \angle 45^\circ$$

$$\cos \phi = 0.8, \phi = \cos^{-1}(0.8) = 36^\circ 50'$$

Now, E_0 leads I by 45° and V leads I by $36^\circ 50'$. Hence, E_0 leads V by $(45^\circ - 36^\circ 50') = 8^\circ 10'$. $\therefore \alpha = 8^\circ 10'$. As before, $\delta = 2^\circ$ (elect).

As seen from Art. 37.36, $P_{SY} = \frac{EV}{X_s} \cos \alpha \sin \delta$ —per phase

$$= 6533 \times 5775 \times \cos 8^\circ 10' \sin 2^\circ / 4 = 326 \text{ kW}$$

$$P_{SY} \text{ for three phases} = 3 \times 326 = 978 \text{ kW}$$

$$T_{SY} \text{ unit displacement} = 9.55 \times 978 \times 10^3 / 1500 = 6,237 \text{ N-m}$$

$$T_{SY} \text{ for } 0.5^\circ \text{ displacement} = 6,237 / 2 = \mathbf{3118.5 \text{ N-m}}$$

(c) We could also use the approximate expression of Art. 37.36

$$P_{SY} \text{ per phase} = \alpha E V / X_s = (\pi / 90) \times 6533 \times 5775 / 4 = \mathbf{329.3 \text{ kW}}$$

Example 37.49. Two 3-phase, 6.6-kW, star-connected alternators supply a load of 3000 kW at 0.8 p.f. lagging. The synchronous impedance per phase of machine A is $(0.5 + j10) \Omega$ and of machine B is $(0.4 + j12) \Omega$. The excitation of machine A is adjusted so that it delivers 150 A at a lagging power factor and the governors are so set that load is shared equally between the machines. Determine the current, power factor, induced e.m.f. and load angle of each machine.

(Electrical Machines-II, South Gujarat Univ. 1985)

Solution. It is given that each machine carries a load of 1500 kW. Also, $V = 6600 / \sqrt{3} = 3810 \text{ V}$. Let $V = 3810 \angle 0^\circ = (3810 + j0)$.

For machine No. 1

$$\sqrt{3} / 6600 \times 1500 \times \cos \phi_1 = 1500 \times 10^3;$$

$$\cos \phi_1 = 0.874, \phi_1 = 29^\circ; \sin \phi_1 = 0.485$$

$$\text{Total current } I = 3000 / \sqrt{3} \times 6.6 \times 0.8 = 328 \text{ A}$$

$$\text{or } I = 828 (0.8 - j0.6) = 262 - j195$$

$$\text{Now, } \mathbf{I_1} = 150 (0.874 - j0.485) = 131 - j72.6$$

$$\therefore \mathbf{I_2} = (262 - j195) - (131 - j72.6)$$

$$= (131 - j124.4)$$

$$\text{or } I_2 = \mathbf{181 \text{ A}}, \cos \phi_2 = 131/181 = \mathbf{0.723 \text{ (lag)}}$$

$$\mathbf{E_A} = \mathbf{V} + \mathbf{I_1 Z_1} = 3810 + (131 - j72.6) (0.5 + j10)$$

$$= 4600 + j1270$$

$$\text{Line value of e.m.f.} = \sqrt{3} \sqrt{4600^2 + 1270^2} = \mathbf{8,260 \text{ V}}$$

$$\text{Load angle } \alpha_1 = (1270/4600) = \mathbf{15.4^\circ}$$

$$\mathbf{E_B} = \mathbf{V} + \mathbf{I_2 Z_2} = 3810 + (131 - j124.4) (0.4 + j12)$$

$$= 5350 + j1520$$

$$\text{Line value of e.m.f.} = \sqrt{3} \sqrt{5350^2 + 1520^2} = \mathbf{9600 \text{ V}}$$

$$\text{Load angle } \alpha_2 = \tan^{-1} (1520/5350) = \mathbf{15.9^\circ}$$

Example 37.50. Two single-phase alternator operating in parallel have induced e.m.fs on open circuit of $230 \angle 0^\circ$ and $230 \angle 10^\circ$ volts and respective reactances of $j2 \Omega$ and $j3 \Omega$. Calculate (i) terminal voltage (ii) currents and (iii) power delivered by each of the alternators to a load of impedance 6Ω (resistive). (Electrical Machines-II, Indore Univ. 1987)

Solution. Here, $Z_1 = j2, Z_2 = j3, Z = 6; E_1 = 230 \angle 0^\circ$ and

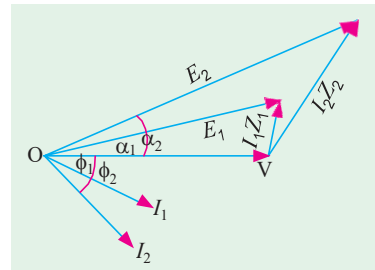

Fig. 37.90

$$E_2 = 230 \angle 10^\circ = 230 (0.985 + j 0.174) = (226.5 + j 39.9), \text{ as in Fig. 37.90}$$

$$(ii) \mathbf{I}_1 = \frac{(E_1 - E_2) Z + E_1 Z_2}{Z(Z_1 + Z_2) + Z_1 Z_2} = \frac{[(230 + j0) - (226.5 + j39.9)] \times 6 + 230 \times j3}{6(j2 - j3) + j2 \times j3}$$

$$= 14.3 - j3.56 = 14.73 \angle -14^\circ \quad \text{---Art. 37.38}$$

$$\mathbf{I}_2 = \frac{(E_2 - E_1) Z + E_2 Z_1}{Z(Z_1 + Z_2) + Z_1 Z_2} = \frac{(-3.5 + j39.9) + (222.5 + j39.9) \times j2}{6(j2 + j3) + j2 \times j3}$$

$$= 22.6 - j 1.15 = 22.63 \angle -3.4^\circ$$

$$(i) \quad \mathbf{I} = \mathbf{I}_1 + \mathbf{I}_2 = 36.9 - j 4.71 = 37.2 \angle -7.3^\circ$$

$$\mathbf{V} = \mathbf{I} \mathbf{Z} = (36.9 - j4.71) \times 6 = 221.4 - j28.3 = 223.2 \angle -7.3^\circ$$

$$(iii) \quad P_1 = V I_1 \cos \phi_1 = 223.2 \times 14.73 \times \cos 14^\circ = \mathbf{3190 \text{ W}}$$

$$P_2 = V I_2 \cos \phi_2 = 223.2 \times 22.63 \times \cos 3.4^\circ = \mathbf{5040 \text{ W}}$$

Tutorial Problem No. 37.6.

- Calculate the synchronizing torque for unit mechanical angle of phase displacement for a 5,000-kVA, 3- ϕ alternator running at 1,500 r.p.m. when connected to 6,600-volt, 50-Hz bus-bars. The armature has a short-circuit reactance of 15%. **[43,370 kg-m] (City & Guilds, London)**
- Calculate the synchronizing torque for one mechanical degree of phase displacement in a 6,000-kVA, 50-Hz, alternator when running at 1,500 r.p.m with a generated e.m.f. of 10,000 volt. The machine has a synchronous impedance of 25%. **[544 kg.m] (Electrical Engineering-III, Madras Univ. April 1978; Osmania Univ. May 1976)**
- A 10,000-kVA, 6,600-V, 16-pole, 50-Hz, 3-phase alternator has a synchronous reactance of 15%. Calculate the synchronous power per mechanical degree of phase displacement from the full load position at power factor 0.8 lagging. **[10 MW] (Elect. Machines-I, Gwalior Univ. 1977)**
- A 6.6 kV, 3-phase, star-connected turbo-alternator of synchronous reactance 0.5 ohm/phase is applying 40 MVA at 0.8 lagging p.f. to a large system. If the steam supply is suddenly cut off, explain what takes place and determine the current the machine will then carry. Neglect losses. **[2100 A] (Elect. Machines (E-3) AMIE Sec. B Summer 1990)**
- A 3-phase 400 kVA, 6.6 kV, 1500 rpm., 50 Hz alternator is running in parallel with infinite bus bars. Its synchronous reactance is 25%. Calculate (i) for no load (ii) full load 0.8 p.f. lagging the synchronizing power and torque per unit mechanical angle of displacement. **[Rajive Gandhi Technical University, 2000] [(i) 55.82 kW, 355 Nw-m (ii) 64.2 kW, 409 Nw-m]**

Effect of Unequal Voltages

Let us consider two alternators, which are running exactly in-phase (relative to the external circuit) but which have slightly unequal voltages, as shown in Fig. 37.91. If E_1 is greater than E_2 , then their resultant is $E_r = (E_1 - E_2)$ and is in-phase with E_1 . This E_r or E_{SY} set up a local synchronizing current I_{SY} which (as discussed earlier) is almost 90° behind E_{SY} and hence behind E_1 also. This lagging current produces demagnetising effect (Art. 37.16) on the first machine, hence E_1 is reduced. The other machine runs as a synchronous motor, taking almost 90° leading current. Hence, its field is strengthened due to magnetising effect of armature reaction (Art. 37.16). This tends to increase E_2 . These two effects act together and hence lessen the inequalities between the two voltages and tend to establish stable conditions.

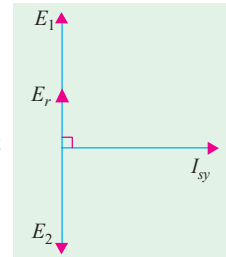

Fig. 37.91

37.40. Distribution of Load

It will, now be shown that the amount of load taken up by an alternator running, in parallel with other

machines, is solely determined by its driving torque *i.e.* by the power input to its prime mover (by giving it more or less steam, in the case of steam drive). Any alternation in its excitation merely changes its kVA output, but not its kW output. In other words, it merely changes the power factor at which the load is delivered.

(a) Effect of Change in Excitation

Suppose the initial operating conditions of the two parallel alternators are identical *i.e.* each alternator supplies one half of the active load (kW) and one-half of the reactive load (kVAR), the operating power factors thus being equal to the load p.f. In other words, both active and reactive powers are divided equally thereby giving equal apparent power triangles for the two machines as shown in Fig. 37.92 (b). As shown in Fig. 37.92 (a), each alternator supplies a load current I so that total output current is $2I$.

Now, let excitation of alternator No. 1 be increased, so that E_1 becomes greater than E_2 . The difference between the two e.m.f.s. sets up a circulating current $I_C = I_{SY} = (E_1 - E_2)/2Z_S$ which is confined to the local path through the armatures and round the bus-bars. This current is superimposed on the original current distribution. As seen, I_C is vectorially added to the load current of alternator No. 1 and subtracted from that of No. 2. The two machines now deliver load currents I_1 and I_2 at respective power factors of $\cos \phi_1$ and $\cos \phi_2$. These changes in load currents lead to changes in power factors, such that $\cos \phi_1$ is reduced, whereas $\cos \phi_2$ is increased. However, effect on the

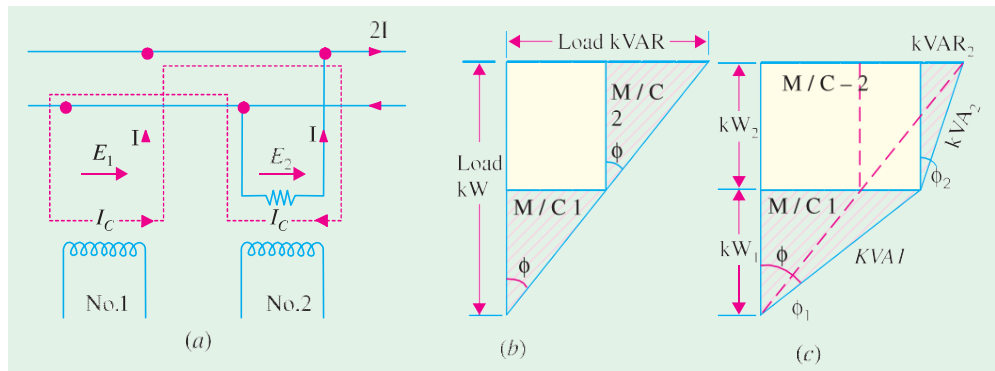

Fig. 37.92

kW loading of the two alternators is negligible, but $kVAR_1$ supplied by alternator No. 1 is increased, whereas $kVAR_2$ supplied by alternator No. 2 is correspondingly decreased, as shown by the kVA triangles of Fig. 37.92 (c).

(b) Effect of Change in Steam Supply

Now, suppose that excitations of the two alternators are kept the same but steam supply to alternator No. 1 is increased *i.e.* power input to its prime mover is increased. Since the speeds of the two machines are tied together by their synchronous bond, machine No. 1 cannot overrun machine No. 2. Alternatively, it utilizes its increased power input for carrying

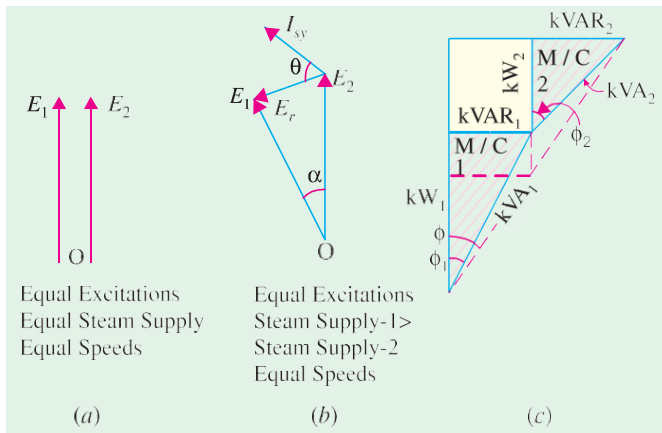

Fig. 37.93

more load than No. 2. This can be made possible only when rotor No. 1 advances its angular position with respect to No. 2 as shown in Fig. 37.93 (b) where E_1 is shown advanced ahead of E_2 by an angle α . Consequently, resultant voltage E_r (or E_{sy}) is produced which, acting on the local circuit, sets up a current I_{sy} which lags by almost 90° behind E_r , but is almost in phase with E_1 (so long as angle α is small). Hence, power per phase of No. 1 is increased by an amount $= E_1 I_{sy}$, whereas that of No. 2 is decreased by the same amount (assuming total load power demand to remain unchanged). Since I_{sy} has no appreciable reactive (or quadrature) component, the increase in steam supply does not disturb the division of reactive powers, but it increases the active power output of alternator No. 1 and decreases that of No. 2. Load division, when steam supply to alternator No. 1 is increased, is shown in Fig. 37.93 (c).

So, it is found that by increasing the input to its prime mover, an alternator can be made to take a greater share of the load, though at a different power factor.

The points worth remembering are :

1. The load taken up by an alternators directly depends upon its driving torque or in other words, upon the angular advance of its rotor.
2. The excitation merely changes the p.f. at which the load is delivered without affecting the load so long as steam supply remains unchanged.
3. If input to the prime mover of an alternator is kept constant, but its excitation is changed, then kVA component of its output is changed, not kW.

Example 37.51. Two identical 3-phase alternators work in parallel and supply a total load of 1, 500 kW at 11 kV at a power factor of 0.867 lagging. Each machine supplies half the total power. The synchronous reactance of each is 50Ω per phase and the resistance is 4Ω per phase. The field excitation of the first machine is so adjusted that its armature current is 50 A lagging. Determine the armature current of the second alternator and the generated voltage of the first machine.

(Elect. Technology, Utkal Univ. 1983)

Solution. Load current at 0.867 p.f. lagging is

$$= \frac{1,500 \times 1,000}{\sqrt{3} \times 11,000 \times 0.867} = 90.4 \text{ A}; \cos \phi = 0.867; \sin \phi = 0.4985$$

Wattful component of the current = $90.4 \times 0.867 = 78.5 \text{ A}$

Wattless component of the current = $90.4 \times 0.4985 = 45.2 \text{ A}$

Each alternator supplies half of each of the above two component when conditions are identical (Fig. 37.94).

Current supplied by each machine = $90.4/2 = 45.2 \text{ A}$

Since the steam supply of first machine is not changed, the working components of both machines would remain the same at $78.5/2 = 39.25 \text{ A}$. But the wattless or reactive components would be redivided due to change in excitation. The armature current of the first machine is changed from 45.2 A to 50 A.

$$\therefore \text{Wattless component of the 1st machine} = \sqrt{50^2 - 39.25^2} = 31 \text{ A}$$

$$\text{Wattless component of the 2nd machine} = 45.2 - 31 = 14.1 \text{ A}$$

The new current diagram is shown in Fig. 37.95 (a)

$$(i) \text{ Armature current of the 2nd alternator, } I_2 = \sqrt{39.25^2 + 14.1^2} = 41.75 \text{ A}$$

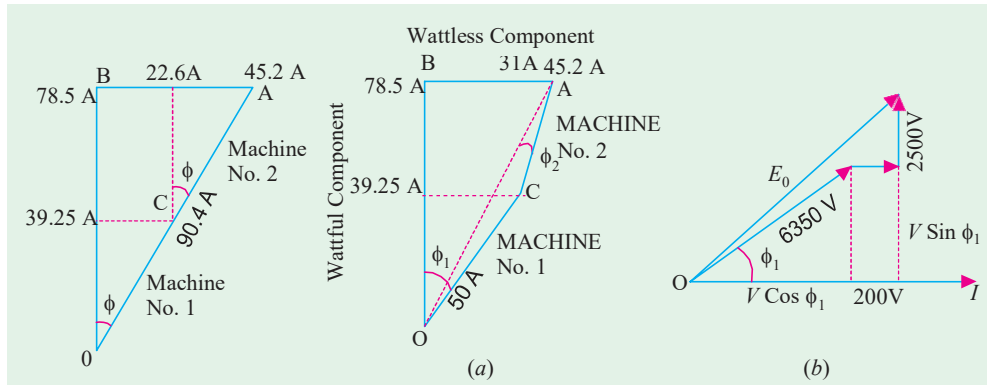

Fig. 37.94

Fig. 37.95

(ii) Terminal voltage / phase = $11,000 / \sqrt{3} = 6350 \text{ V}$

Considering the first alternator,

$$IR \text{ drop} = 4 \times 50 = 200 \text{ V}; IX \text{ drop} = 50 \times 50 = 2,500 \text{ V}$$

$$\cos \phi_1 = 39.25/50 = 0.785; \sin \phi_1 = 0.62$$

Then, as seen from Fig. 37.95 (b)

$$E = \sqrt{(V \cos \phi_1 + IR)^2 + (V \sin \phi_1 + IX)^2}$$

$$= \sqrt{(6,350 \times 0.785 + 200)^2 + (6,350 \times 0.62 + 2,500)^2} = 8,350 \text{ V}$$

$$\text{Line voltage} = 8,350 \times \sqrt{3} = 14,450 \text{ V}$$

Example 37.52. Two alternators A and B operate in parallel and supply a load of 10 MW at 0.8 p.f. lagging (a) By adjusting steam supply of A, its power output is adjusted to 6,000 kW and by changing its excitation, its p.f. is adjusted to 0.92 lag. Find the p.f. of alternator B.

(b) If steam supply of both machines is left unchanged, but excitation of B is reduced so that its p.f. becomes 0.92 lead, find new p.f. of A.

Solution. (a) $\cos \phi = 0.8, \phi = 36.9^\circ, \tan \phi = 0.7508; \cos \phi_A = 0.92, \phi_A = 23^\circ; \tan \phi_A = 0.4245$
 load kW = 10,000, load kVAR = $10,000 \times 0.7508 = 7508 \text{ (lag)}$
 kW of A = 6,000, kVAR of A = $6,000 \times 0.4245 = 2547 \text{ (lag)}$

Keeping in mind the convention that lagging kVAR is taken as negative we have,

$$\text{kW of B} = (10,000 - 6,000) = 4,000; \text{kVAR of B} = (7508 - 2547) = 4961 \text{ (lag)}$$

$$\therefore \text{kVA of B} = 4,000 - j4961 = 6373 \angle -51.1^\circ; \cos \phi_B = \cos 51.1^\circ = 0.628$$

(b) Since steam supply remains unchanged, load kW of each machine remains as before but due to change in excitation, kVARs of the two machines are changed.

$$\text{kW of B} = 4,000, \text{ new kVAR of B} = 4000 \times 0.4245 = 1698 \text{ (lead)}$$

$$\text{kW of A} = 6,000, \text{ new kVAR of A} = -7508 - (+1698) = -9206 \text{ (lag.)}$$

$$\therefore \text{ new kVA of A} = 6,000 - j9206 = 10,988 \angle -56.9^\circ; \cos \phi_A = 0.546 \text{ (lag)}$$

Example 37.53. A 6,000-V, 1,000-kVA, 3- ϕ alternator is delivering full-load at 0.8 p.f. lagging. Its reactance is 20% and resistance negligible. By changing the excitation, the e.m.f. is increased by 25% at this load. Calculate the new current and the power factor. The machine is connected to infinite bus-bars.

Solution. Full-load current $I = \frac{1,000,000}{\sqrt{3} \times 6,600} = 87.5 \text{ A}$

$$\begin{aligned} \text{Voltage/phase} &= 6,600/\sqrt{3} = 3,810 \text{ V} \\ \text{Reactance} &= \frac{3810 \times 20}{87.5 \times 100} = 8.7 \Omega \\ IX &= 20\% \text{ of } 3810 = 762 \text{ V} \end{aligned}$$

In Fig. 37.96, current vector is taken along X-axis. ON represents bus-bar or terminal voltage and is hence constant.

Current I has been split up into its active and reactive components I_R and I_X respectively.

$$\begin{aligned} NA_1 = I_X X &= 52.5 \times 7.8 = 457 \text{ V} \\ A_1 C_1 = I_R X &= 70 \times 8.7 = 609 \text{ V} \end{aligned}$$

$$\begin{aligned} E_0 = OC_1 &= \sqrt{[(V + I_X X)^2 + (I_R X)^2]} \\ &= \sqrt{[(3,810 + 457)^2 + 609^2]} = 4,311 \text{ V} \end{aligned}$$

When e.m.f. is increased by 25%, then E_0 becomes equal to $4,311 \times 1.25 = 5,389 \text{ V}$

The locus of the extremity of E_0 lies on the line EF which is parallel to ON . Since the kW is unchanged, I_R and hence $I_R X$ will remain the same. It is only the $I_X X$ component which will be changed. Let OC_2 be the new value of E_0 . Then $A_2 C_2 = A_1 C_1 = I_R X$ as before. But the $I_X X$ component will change. Let I be the new line current having active component I_R (the same as before) and the new reactive component I_X' . Then, $I_X' X = NA_2$

From right-angled triangle $OC_2 A_2$

$$OC_2^2 = OA_2^2 + A_2 C_2^2; 5,389^2 = (3810 + VA_2)^2 + 609^2$$

$$\therefore VA_2 = 1546 \text{ V or } I_X' X = 1546$$

$$\therefore I_X' = 1546/8.7 = 177.7 \text{ A}$$

$$\therefore \text{New line current } I = \sqrt{(70^2 + 177.7^2)} = 191 \text{ A}$$

$$\text{New angle of lag, } \phi = \tan^{-1}(177.7/70) = 68^\circ 30'; \cos \phi = \cos 68^\circ 30' = 0.3665$$

$$\text{As a check, the new power} = \sqrt{3} \times 6,600 \times 191 \times 0.3665 = 800 \text{ kW}$$

$$\text{It is the same as before} = 1000 \times 0.8 = 800 \text{ kW}$$

Example 37.54. A 6,600-V, 1000-kVA alternator has a reactance of 20% and is delivering full-load at 0.8 p.f. lagging. It is connected to constant-frequency bus-bars. If steam supply is gradually increased, calculate (i) at what output will the power factor become unity (ii) the maximum load which it can supply without dropping out of synchronism and the corresponding power factor.

Solution. We have found in Example 37.52 that

$$I = 87.5 \text{ A, } X = 8.7 \Omega, V/\text{phase} = 3,810 \text{ V}$$

$$E_0 = 4,311 \text{ V, } I_R = 70 \text{ A, } I_X = 52.5 \text{ A and}$$

$$IX = 87.5 \times 8.7 = 762 \text{ V}$$

Using this data, vector diagram of Fig. 37.97 can be constructed.

Since excitation is constant, E_0 remains constant, the extremity of E_0 lies on the arc of a circle of radius E_0 and centre O . Constant power lines have been shown dotted and they are all parallel to OV . Zero power output line coincides with OV . When p.f. is unity, the current vector lies along OV , $I_1 Z$ is \perp to OV and cuts the arc at B_1 . Obviously

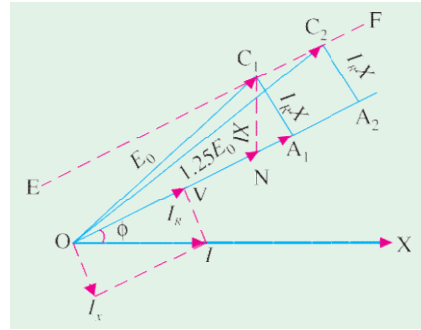

Fig. 37.96

$$VB_1 = \sqrt{(OB_1^2 - OV^2)}$$

$$= \sqrt{(4,311^2 - 3,810^2)} = 2018 \text{ V}$$

Now $Z = X \therefore I_1 X = 2,018 \text{ V}$

$$\therefore I_1 = 2018/8.7 = 232 \text{ A}$$

(i) \therefore power output at u.p.f.

$$= \frac{\sqrt{3} \times 6,600 \times 232}{1000} = 2,652 \text{ kW}$$

(ii) As vector OB moves upwards along the arc, output power goes on increasing i.e., point B shifts on to a higher output power line. Maximum output power is reached when OB reaches the position OB_2 where it is vertical to OV . The output power line passing through B_2 represents the maximum output for that excitation. If OB is further rotated, the point B_2 shifts down to a lower power line i.e. power is decreased. Hence, $B_2 V = I_2 Z$ where I_2 is the new current corresponding to maximum output.

From triangle $OB_2 V$, it is seen that

$$B_2 V = \sqrt{(OV^2 + OB^2)} = \sqrt{(3,810^2 + 4,311^2)} = 5,753 \text{ V}$$

$$\therefore I_2 Z = 5,753 \text{ V} \therefore I_2 = 5753/8.7 = 661 \text{ A}$$

Let I_{2R} and I_{2X} be the power and wattless components of I_2 , then

$$I_{2R} X = OB_2 = 4311 \text{ and } I_{2R} = 4311/8.7 = 495.6 \text{ A}$$

$$\text{Similarly } I_{2X} = 3810/8.7 = 438 \text{ A; } \tan \phi_2 = 438/495.6 = 0.884$$

$$\therefore \phi_2 = 41^\circ 28'; \cos \phi_2 = 0.749$$

$$\therefore \text{Max. power output} = \frac{\sqrt{3} \times 6,600 \times 661 \times 0.749}{1000} = 5,658 \text{ kW}$$

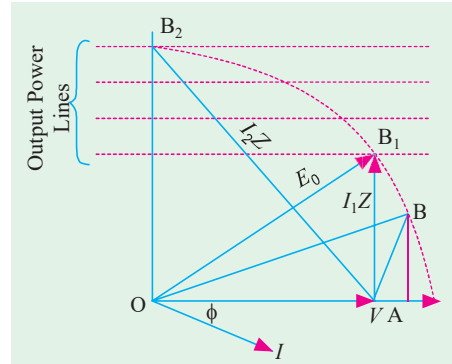

Fig. 37.97

Example 37.55. A 3-phase, star-connected turbo-alternator, having a synchronous reactance of 10Ω per phase and negligible armature resistance, has an armature current of 220 A at unity p.f. The supply voltage is constant at 11 kV at constant frequency. If the steam admission is unchanged and the e.m.f. raised by 25% , determine the current and power factor.

If the higher value of excitation is maintained and the steam supply is slowly increased, at what power output will the alternator break away from synchronism?

Draw the vector diagram under maximum power condition.

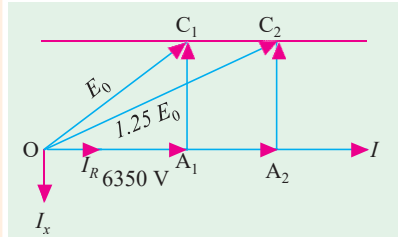

Fig. 37.98

(Elect. Machinery-III, Bangalore Univ. 1992)

Solution. The vector diagram for unity power factor is shown in Fig. 37.98. Here, the current is wholly active.

$$OA_1 = 11,000 / 3\sqrt{3} = 6,350 \text{ V}$$

$$A_1 C_1 = 220 \times 10 = 2,200 \text{ V}$$

$$E_0 = \sqrt{(6350^2 + 2,200^2)} = 6,810 \text{ V}$$

When e.m.f. is increased by 25% , the e.m.f. becomes $1.25 \times 6,810 = 8,512 \text{ V}$ and is represented by OC_2 . Since the kW remains unchanged, $A_1 C_1 = A_2 C_2$. If I is the new current, then its active component

I_R would be the same as before and equal to 220 A. Let its reactive component be I_X . Then

$$A_1 A_2 = I_X X_S = 10 I_X$$

From right-angled $\Delta OA_2 C_2$, we have
 $8,512^2 = (6350 + A_1 A_2)^2 + 2,200^2$

$$\therefore A_1 A_2 = 1870 \text{ V} \quad \therefore 10 I_X = 1870 \quad I_X = 187 \text{ A}$$

Hence, the new current has active component of 220 A and a reactive component of 187 A.

$$\text{New current} = \sqrt{220^2 + 187^2} = \mathbf{288.6 \text{ A}}$$

$$\text{New power factor} = \frac{\text{active component}}{\text{total current}} = \frac{220}{288.6} = \mathbf{0.762 \text{ (lag)}}$$

Since excitation remains constant, E_0 is constant. But as the steam supply is increased, the extremity of E_0 lies on a circle of radius E_0 and centre O as shown in Fig. 37.99.

The constant-power lines (shown dotted) are drawn parallel to OV and each represents the locus of the e.m.f. vector for a constant power output at varying excitation. Maximum power output condition is reached when the vector E_0 becomes perpendicular to OV . In other words, when the circular e.m.f. locus becomes tangential to the constant-power lines i.e. at point B . If the steam supply is increased further, the alternator will break away from synchronism.

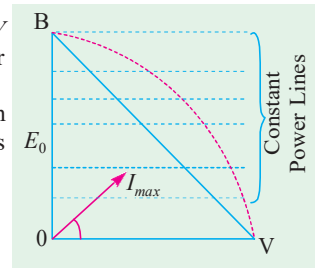

Fig. 37.99

$$B.V. = \sqrt{6350^2 + 8,512^2} = 10,620 \text{ V}$$

$$\therefore I_{\max} \times 10 = 10,620 \text{ or } I_{\max} = 1,062 \text{ A}$$

If I_R and I_X are the active and reactive components of I_{\max} , then

$$10 I_R = 8,512 \quad \therefore I_R = 851.2 \text{ A}; \quad 10 I_X = 6,350 \quad \therefore I_X = 635 \text{ A}$$

$$\text{Power factor at maximum power output} = 851.2/1062 = 0.8 \text{ (lead)}$$

$$\text{Maximum power output} = \sqrt{3} \times 11,000 \times 1062 \times 0.8 \times 10^{-3} = \mathbf{16,200 \text{ kW}}$$

Example 37.56. Two 20-MVA, 3- ϕ alternators operate in parallel to supply a load of 35MVA at 0.8 p.f. lagging. If the output of one machine is 25 MVA at 0.9 lagging, what is the output and p.f. of the other machine? (Elect. Machines, Punjab Univ. 1990)

Solution. Load MW = $35 \times 0.8 = 28$; load MVAR = $35 \times 0.6 = 21$

First Machine $\cos \phi_1 = 0.9, \sin \phi_1 = 0.436$; MVA₁ = 25, MW₁ = $25 \times 0.9 = 22.5$
 MVAR₁ = $25 \times 0.436 = 10.9$

Second Machine MW₂ = MW – MW₁ = $28 - 22.5 = 5.5$
 MVAR₂ = MVAR – MVAR₁ = $21 - 10.9 = 10.1$

$$\therefore \text{MVA}_2 = \sqrt{\text{MW}_2^2 + \text{MVAR}_2^2} = \sqrt{5.5^2 + 10.1^2} = \mathbf{11.5}$$

$$\cos \phi_2 = 5.5/11.5 = \mathbf{0.478 \text{ (lag)}}$$

Example 37.57. A lighting load of 600 kW and a motor load of 707 kW at 0.707 p.f. are supplied by two alternators running in parallel. One of the machines supplies 900 kW at 0.9 p.f. lagging. Find the load and p.f. of the second machine. (Electrical Technology, Bombay Univ. 1988 & Bharatiar University, 1997)

Solution.

	Active Power	kVA	Reactive Power
(a) Lighting Load (unity P.f.)	600 kW	600	—
(b) Motor, 0.707 P.f.	707 kW	1000	707 k VAR
Total Load :	1307	By Phasor addition	707 k VAR

One machine supplies an active power of 900 kW, and due to 0.9 lagging p.f., kVA = 1000 kVA and its kVAR = $1000 \times \sqrt{(1 - 0.9^2)} = 436$ kVAR. Remaining share will be catered to by the second machine.

Active power shared by second machine = $1307 - 900 = 407$ kW

Reactive power shared by second machine = $707 - 436 = 271$ kVAR

Example 37.58. Two alternators, working in parallel, supply the following loads :

(i) Lighting load of 500 kW (ii) 1000 kW at p.f. 0.9 lagging

(iii) 800 kW at p.f. 0.8 lagging (iv) 500 kW at p.f. 0.9 leading

One alternator is supplying 1500 kW at 0.95 p.f. lagging. Calculate the kW output and p.f. of the other machine.

Solution. We will tabulate the kW and kVAR components of each load separately :

Load	kW	kVAR
(i)	500	
(ii)	1000	$\frac{1000}{0.9} \times 0.436 = 485$
(iii)	800	$\frac{800 \times 0.6}{0.8} = 600$
(iv)	500	$\frac{500 \times 0.436}{0.9} = -242$
Total	2800	+ 843

For 1st machine, it is given : kW = 1500, kVAR = $(1500/0.95) \times 0.3123 = 493$

∴ kW supplied by other machine = $2800 - 1500 = 1300$

kVAR supplied = $843 - 493 = 350$ ∴ $\tan \phi = 350/1300 = 0.27$ ∴ $\cos \phi = 0.966$

Example 37.59 Two 3- ϕ synchronous mechanically-coupled generators operate in parallel on the same load. Determine the kW output and p.f. of each machine under the following conditions: synchronous impedance of each generator : $0.2 + j2$ ohm/phase. Equivalent impedance of the load : $3 + j4$ ohm/phase. Induced e.m.f. per phase, 2000 + j0 volt for machine I and 2,200 + j 100 for II.

[London Univ.]

Solution. Current of 1st machine $= \mathbf{I} = \frac{\mathbf{E}_1 - \mathbf{V}}{0.2 + j2}$ or $\mathbf{E}_1 - \mathbf{V} = \mathbf{I}_1 (0.2 + j2)$

Similarly $\mathbf{E}_2 - \mathbf{V} = \mathbf{I}_2 (0.2 + j2)$

Also $\mathbf{V} = (\mathbf{I}_1 + \mathbf{I}_2) (3 + j4)$ where $3 + j4 =$ load impedance

Now $\mathbf{E}_1 = 2,000 + j0$, $\mathbf{E}_2 = 2,200 + j100$

Solving from above, we get $\mathbf{I}_1 = 68.2 - j 102.5$

Similarly $\mathbf{I}_2 = 127 - j 196.4$; $\mathbf{I} = \mathbf{I}_1 + \mathbf{I}_2 = 195.2 - j299$

Now $\mathbf{V} = \mathbf{IZ} = (192.2 - j 299) (3 + j 4) = 1781 - j 115.9$

Using the method of conjugate for power calculating, we have for the first machine

$$P_{VA1} = (1781 - j 115.9) (68.2 + j 102.5) = 133,344 + j 174,648$$

∴ $kW_1 = 133.344$ kW/phase = $3 \times 133.344 = 400$ kW —for 3phases

Now $\tan^{-1}(102.5/68.2) = 56^\circ 24'$; $\tan^{-1}(115.9/1781) = 3^\circ 43'$

∴ for 1st machine ; $\cos(56^\circ 24' - 3^\circ 43') = 0.6062$

$$PVA_2 = (1781 - j115.9)(127 + j196.4) = 248,950 + j335,069$$

$$\therefore kW_2 = 248.95 \text{ kW/phase} = 746.85 \text{ kW} \quad \text{---for 3 phases}$$

$$\tan^{-1}(196.4/127) = 57^\circ 6'; \cos \phi = \cos(57^\circ 6' 3^\circ 43) = \mathbf{0.596}$$

Example 37.60. The speed regulations of two 800-kW alternators A and B, running in parallel, are 100% to 104% and 100% to 105% from full-load to no-load respectively. How will the two alternators share a load of 1000 kW? Also, find the load at which one machine ceases to supply any portion of the load. (Power Systems-I, A.M.I.E. 1989)

Solution. The speed / load characteristics (assumed straight) for the alternators are shown in Fig. 37.100. Out of the combined load $AB = 1000 \text{ kW}$, A's share is AM and B's share is BM . Hence, $AM + BM = 1000 \text{ kW}$. PQ is the horizontal line drawn through point C, which is the point of intersection.

From similar Δs GDA and CDP , we have

$$\frac{CP}{GA} = \frac{PD}{AD} \text{ or}$$

$$CP = GA \cdot \frac{PD}{AD}$$

Since,

$$PD = (4 - h)$$

$$\therefore CP = 800(4 - h)/4$$

$$= 200(4 - h)$$

Similarly, from similar Δs BEF and QEC , we get

$$\frac{QC}{BF} = \frac{QE}{BE} \text{ or}$$

$$QC = 800(5 - h)/5$$

$$= 160(5 - h)$$

$$\therefore CP + QC = 1000 \text{ or } 200(4 - h) + 160(5 - h) = 1000 \text{ or } h = 5/3$$

$$\therefore CP = 200(4 - 5/3) = 467 \text{ kW}, QC = 160(5 - 5/3) = 533 \text{ kW}$$

Hence, alternator A supplies **467 kW** and B supplies **533 kW**.

Alternator A will cease supplying any load when line PQ is shifted to point D. Then, load supplied by alternator B (= BN) is such that the speed variation is from 105% to 104%.

Knowing that when its speed varies from 105% to 100%, alternator B supplies a load of 800 kW, hence load supplied for speed variation from 105% to 100% is (by proportion)

$$= 800 \times 1/5 = \mathbf{160 \text{ kW} (= BN)}$$

Hence, when load drops from 1000 kW to 160 kW, alternator A will cease supplying any portion of this load.

Example 37.61. Two 50-MVA, 3- ϕ alternators operate in parallel. The settings of the governors are such that the rise in speed from full-load to no-load is 2 per cent in one machine and 3 per cent in the other, the characteristics being straight lines in both cases. If each machine is fully loaded when the total load is 100 MW, what would be the load on each machine when the total load is 60 MW? (Electrical Machines-II, Punjab Univ. 1991)

Solution. Fig. 37.101 shows the speed/load characteristics of the two machines, NB is of the first machine and MA is that of the second. Base AB shows equal load division at full-load and speed. As the machines are running in parallel, their frequencies must be the same. Let CD be drawn through x% speed where total load is 60 MW.

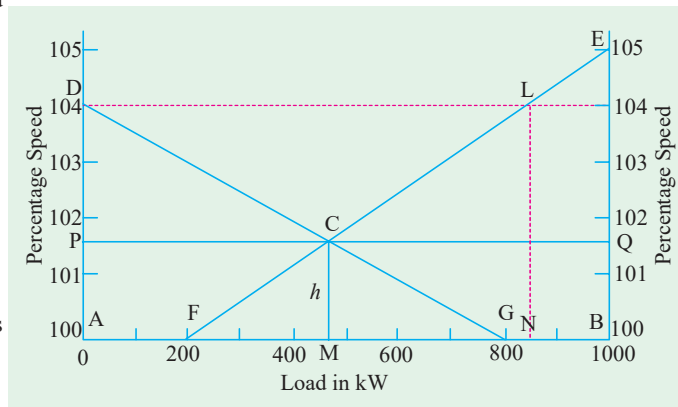

Fig. 37.100

$$CE = 50 - AP = 50 - \frac{50}{3}x$$

$$ED = 50 - QB = 50 - \frac{50}{2}x$$

$$\therefore CD = 50 - (50/3)x + 50 - 25x$$

$$\therefore 60 = \frac{50}{3} - (50/3)x + 50 - \frac{25}{2}x$$

$$x = \frac{24}{25}; \therefore LE = 100 \frac{24}{25} \%$$

Load supplied by 1st machine

$$= ED = 50 - 25 \times \frac{24}{25} = 26 \text{ MW}$$

Load supplied by 2nd machine.

$$= CE = 50 - \left(\frac{50}{3}\right) \times \frac{24}{25} = 34 \text{ MW}$$

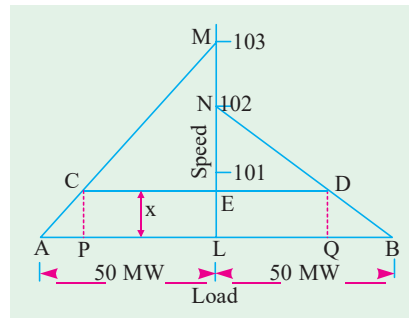

Fig. 37.101

Example 37.62. Two identical 2,000 -kVA alternators operate in parallel. The governor of the first machine is such that the frequency drops uniformly from 50-Hz on no-load to 48-Hz on full-load. The corresponding uniform speed drop of the second machines is 50 to 47.5 Hz (a) How will the two machines share a load of 3,000 kW? (b) What is the maximum load at unity p.f. that can be delivered without overloading either machine ? (Electrical Machinery-II, Osmania Univ. 1989)

Solution. In Fig. 37.102 are shown the frequency/load characteristics of the two machines, AB is that of the second machine and AD that of the first. Remembering that the frequency of the two machines must be the same at any load, a line MN is drawn at a frequency x as measured from point A (common point).

Total load at that frequency is

$$NL + ML = 3000 \text{ kW}$$

From $\Delta s ABC$ and ANL , $NL/2000 = x / 2.5$

$$\therefore NL = 2000 x/2.5 = 800 x$$

Similarly, $ML = 2000 x/2 = 1000x$

$$\therefore 1800 x = 3000 \text{ or } x = 5/3$$

Frequency = $50 - 5/3 = 145/3 \text{ Hz}$.

(a) $NL = 800 \times 5/3 = 1333 \text{ kW (assuming u.p.f.)}$

$ML = 1000 \times 5/3 = 1667 \text{ kW (assuming u.p.f.)}$

(b) For getting maximum load, DE is extended to cut AB at F. Max. load = DF.

Now, $EF = 2000 \times 2/3.5 = 1600 \text{ kW}$

$\therefore \text{Max. load} = DF = 2,000 + 1,600 = 3,600 \text{ kW.}$

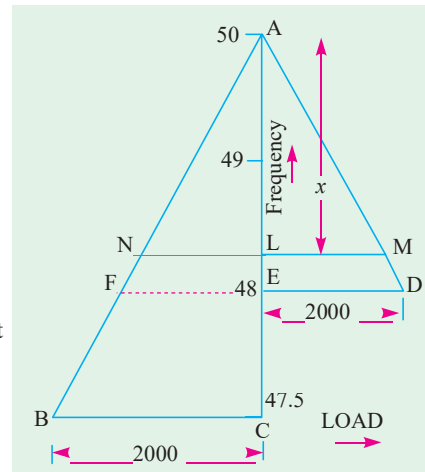

Fig. 37.102

Tutorial Problem No. 37.7

- Two similar 6,600-V, 3- ϕ , generators are running in parallel on constant-voltage and frequency bus-bars. Each has an equivalent resistance and reactance of 0.05 Ω and 0.5 Ω respectively and supplies one half of a total load of 10,000 kW at a lagging p.f. of 0.8, the two machines being similarly excited. If the excitation of one machine be adjusted until the armature current is 438 A and the steam supply to the turbine remains unchanged, find the armature current, the e.m.f. and the p.f. of the other alternator. [789 A, 7200 V, 0.556] (City & Guilds, London)

- 2 A single-phase alternator connected to 6,600-V bus-bars has a synchronous impedance of 10Ω and a resistance of 1Ω . If its excitation is such that on open circuit the p.d. would be 5000 V, calculate the maximum load the machine can supply to the external circuit before dropping out of step and the corresponding armature current and p.f. **[2864 kW, 787 A, 0.551] (London Univ.)**
- 3 A turbo-alternator having a reactance of 10Ω has an armature current of 220 A at unity power factor when running on 11,000 V, constant-frequency bus-bars. If the steam admission is unchanged and the e.m.f. raised by 25%, determine graphically or otherwise the new value of the machine current and power factor. If this higher value of excitation were kept constant and the steam supply gradually increased, at what power output would the alternator break from synchronism? Find also the current and power factor to which this maximum load corresponds. State whether this p.f. is lagging or leading. **[360 A at 0.611 p.f. ; 15.427 kW ; 1785 A at 0.7865 leading] (City & Guilds, London)**
- 4 Two single-phase alternators are connected to a 50-Hz bus-bars having a constant voltage of $10\angle 0^\circ$ kV. Generator *A* has an induced e.m.f. of $13\angle 22.6^\circ$ kV and a reactance of 2Ω ; generator *B* has an e.m.f. of $12.5\angle 36.9^\circ$ kV and a reactance of 3Ω . Find the current, kW and kVAR supplied by each generator. **(Electrical Machine-II, Indore Univ. July 1977)**
- 5 Two 15-kVA, 400-V, 3-ph alternators in parallel supply a total load of 25 kVA at 0.8 p.f. lagging. If one alternator shares half the power at unity p.f., determine the p.f. and kVA shared by the other alternator. **[0.5548; 18.03 kVA] (Electrical Technology-II, Madras Univ. Apr. 1977)**
- 6 Two 3- ϕ , 6,600-V, star-connected alternators working in parallel supply the following loads :
 (i) Lighting load of 400 kW (ii) 300 kW at p.f. 0.9 lagging
 (iii) 400 kW at p.f. 0.8 lagging (iv) 1000 kW at p.f. 0.71 lagging
 Find the output, armature current and the p.f. of the other machine if the armature current of one machine is 110 A at 0.9 p.f. lagging. **[970 kW, 116 A, 0.73 lagging]**
- 7 A 3- ϕ , star-connected, 11,000-V turbo-generator has an equivalent resistance and reactance of 0.5Ω and 8Ω respectively. It is delivering 200 A at u.p.f. when running on a constant-voltage and constant-frequency bus-bars. Assuming constant steam supply and unchanged efficiency, find the current and p.f. if the induced e.m.f. is raised by 25%. **[296 A, 0.67 lagging]**
- 8 Two similar 13,000-V, 3-ph alternators are operated in parallel on infinite bus-bars. Each machine has an effective resistance and reactance of 0.05Ω and 0.5Ω respectively. When equally excited, they share equally a total load of 18 MW at 0.8 p.f. lagging. If the excitation of one generator is adjusted until the armature current is 400 A and the steam supply to its turbine remains unaltered, find the armature current, the e.m.f. and the p.f. of the other generator. **[774.6 A; 0.5165 ; 13,470 V] (Electric Machinery-II, Madras Univ. Nov. 1977)**

Time-period of Oscillation

Every synchronous machine has a natural time period of free oscillation. Many causes, including the variations in load, create phase-swinging of the machine. If the time period of these oscillations coincides with natural time period of the machine, then the amplitude of the oscillations may become so greatly developed as to swing the machine out of synchronism.

The expression for the natural time period of oscillations of a synchronous machine is derived below :

Let $T =$ torque per mechanical radian (in N-m/mech. radian)
 $J = \sum m r^2$ —moment of inertia in kg-m^2 .

The period of undamped free oscillations is given by $t = 2\pi \sqrt{\frac{J}{T}}$.

We have seen in Art. 37.32 that when an alternator swings out of phase by an angle α (electrical radian), then synchronizing power developed is

$$P_{SY} = \alpha E^2/Z \quad \text{— } \alpha \text{ in elect. radian}$$

$$= \frac{E^2}{Z} \text{ per electrical radian per phase.}$$

Now, 1 electrical radian = $\frac{P}{2} \times$ mechanical radian—where P is the number of poles.

$$\therefore P_{SY} \text{ per mechanical radian displacement} = \frac{E^2 P}{2Z}$$

The synchronizing or restoring torque is given by

$$T_{SY} = \frac{P_{SY}}{2\pi N_s} = \frac{E^2 P}{4\pi Z N_s} \quad \text{--- } N_s \text{ in r.p.s.}$$

Torque for three phases is $T = 3T_{SY} = \frac{3E^2 P}{4\pi Z N_s}$ where E is e.m.f. per phase ... (i)

Now

$$E/Z = \text{short-circuit current} = I_{SC}$$

$$f = PN_s/2; \text{ hence } P/N_s = 2f/N_s$$

Substituting these values in (i) above, we have

$$T_{SY} = \frac{3}{4\pi} \cdot \left(\frac{E}{Z}\right) \cdot E \cdot \frac{P}{N_s} = \frac{3}{4\pi} \cdot I_{SC} \cdot E \cdot \frac{2f}{N_s} = 0.477 \frac{E I_{SC} f}{N_s^2}$$

Now,

$$t = 2\pi \sqrt{\frac{J}{0.477 E I_{SC} f / N_s^2}} = 9.1 N_s \sqrt{\frac{J}{E \cdot I_{SC} \cdot f}} \text{ second}$$

$$= 9.1 N_s \sqrt{\frac{J}{\frac{1}{\sqrt{3}} \cdot E_L \cdot I \cdot (I_{SC}/I) \cdot f}}$$

$$= 9.1 N_s \sqrt{\frac{J}{\frac{1}{2} \cdot \sqrt{3} E_L \cdot I \cdot (I_{SC}/I) \cdot f}}$$

$$= 9.1 N_s \sqrt{\frac{J}{\frac{1000}{3} \cdot \frac{\sqrt{3} \cdot E_L \cdot I \cdot (I_{SC}/I)}{1000} \cdot f}}$$

$$= \frac{9.1 \times \sqrt{3}}{\sqrt{1000}} \cdot N_s \cdot \sqrt{\frac{J}{kVA \cdot (I_{SC}/I) \cdot f}}$$

$$\therefore t = 0.4984 N_s \sqrt{\frac{J}{kVA \cdot (I_{SC}/I) \cdot f}}$$

where kVA = full-load kVA of the alternator; N_s = r.p.s. of the rotating system

If N_s represents the speed in r.p.m., then

$$t = \frac{0.4984}{60} \cdot N_s \sqrt{\frac{J}{kVA \cdot (I_{SC}/I) \cdot f}} = 0.0083 N_s \sqrt{\frac{J}{kVA (I_{SC}/I) \cdot f}} \text{ second}$$

Note. It may be proved that $I_{SC}/I = 100/\text{percentage reactance} = 100/\% X_s$.

$$\text{Proof.} \quad \text{Reactance drop} = I X_s = \frac{V \times \% X_s}{100} \quad \therefore X_s = \frac{\text{reactance drop}}{\text{full-load current}} = \frac{V \times \% X_s}{100 \times I}$$

Now
$$I_{SC} = \frac{V}{X_S} = \frac{V \times 100 \times I}{V \times \% X_S} = \frac{100}{\% X_S} \times I; \text{ or } I_{SC} = \frac{100}{I} \% X_S$$

For example, if synchronous reactance is 25 per cent, then

$$I_{SC}/I = 100/25 = 4 \text{ (please see Ex. 37.64)}$$

Example 37.63. A 5,000-kVA, 3-phase, 10,000-V, 50-Hz alternator runs at 1500 r.p.m. connected to constant-frequency, constant-voltage bus-bars. If the moment of inertia of entire rotating system is $1.5 \times 10^4 \text{ kg}\cdot\text{m}^2$ and the steady short-circuit current is 5 times the normal full-load current, find the natural time period of oscillation. (Elect. Engg. Grad. I.E.T.E. 1991)

Solution. The time of oscillation is given by

$$t = 0.0083 N_S \sqrt{\frac{J}{kVA \cdot (I_{SC}/I)f}} \text{ . second}$$

Here, $N_S = 1500 \text{ r.p.m.}; I_{SC}/I = 5^*$; $J = 1.5 \times 10^4 \text{ kg}\cdot\text{m}^2$; $f = 50 \text{ Hz}$

$$t = 0.0083 \times 1500 \sqrt{\frac{1.5 \times 10^4}{5000 \times 5 \times 50}} = 1.364 \text{ s.}$$

Example 37.64. A 10,000-kVA, 4-pole, 6,600-V, 50-Hz, 3-phase star-connected alternator has a synchronous reactance of 25% and operates on constant-voltage, constant frequency bus-bars. If the natural period of oscillation while operating at full-load and unity power factor is to be limited to 1.5 second, calculate the moment of inertia of the rotating system. (Electric Machinery-II, Andhra Univ. 1990)

Solution.
$$t = 0.0083 N_S \sqrt{\frac{J}{kVA (I_{SC}/I)f}} \text{ second.}$$

Here $I_{SC}/I = 100/25 = 4$; $N_S = 120 \times 50/4 = 1500 \text{ r.p.m.}$

$$\therefore 1.5 = 0.0083 \times 1500 \sqrt{\frac{J}{10,000 \times 4 \times 50}} = 12.45 \times \frac{\sqrt{J}}{10^3 \times \sqrt{2}}$$

$$\therefore J = (1.5 \times 10^3 \times \sqrt{2}/12.45)^2 = 2.9 \times 10^4 \text{ kg}\cdot\text{m}^2$$

Example 37.65. A 10-MVA, 10-kV, 3-phase, 50-Hz, 1500 r.p.m. alternator is paralleled with others of much greater capacity. The moment of inertia of the rotor is $2 \times 10^5 \text{ kg}\cdot\text{m}^2$ and the synchronous reactance of the machine is 40%. Calculate the frequency of oscillation of the rotor. (Elect. Machinery-III, Bangalore Univ. 1992)

Solution. Here, $I_{SC}/I = 100/40 = 2.5$

$$t = 0.0083 \times 1500 \sqrt{\frac{2 \times 10^5}{10^4 \times 2.5 \times 50}} = 5 \text{ second}$$

$$\text{Frequency} = 1/5 = 0.2 \text{ Hz.}$$

* It means that synchronous reactance of the alternator is 20 %.

Tutorial Problem No. 37.8

1. Show that an alternator running in parallel on constant-voltage and frequency bus-bars has a natural time period of oscillation. Deduce a formula for the time of one complete oscillation and calculate its value for a 5000-kVA, 3-phase, 10,000 V machine running at 1500 r.p.m. on constant 50-Hz bus-bars.
The moment of inertia of the whole moving system is 14112 kg-m² and the steady short-circuit current is five times the normal full-load value. **[1.33 second]**
2. A 10,000-kVA, 5-kV, 3-phase, 4-pole, 50-Hz alternator is connected to infinite bus-bars. The short-circuit current is 3.5 times the normal full-load current and the moment of inertia of the rotating system is 21,000 kg-m². Calculate its normal period of oscillation. **[1.365 second]**
3. Calculate for full-load and unity p.f., the natural period of oscillation of a 50-Hz, 10,000-kVA, 11-kV alternator driven at 1500 r.p.m. and connected to an infinite bus-bar. The steady short-circuit current is four times the full-load current and the moment of the inertia of the rotating masses is 17,000 kg-m². **[1.148 s.] (Electrical Machinery-II, Madras Univ. Apr. 1976)**
4. Calculate the rotational inertia in kg-m² units of the moving system of 10,000 kVA, 6,600-V, 4-pole, turbo-alternator driven at 1500 r.p.m. for the set to have a natural period of 1 second when running in parallel with a number of other machines. The steady short-circuit current of the alternator is five times the full-load value. **[16,828 kg-m²] (City & Guilds, London)**
5. A 3-φ, 4-pole, 6,000 kVA, 5,000-V, 50-Hz star-connected alternator is running on constant-voltage and constant-frequency bus-bars. It has a short-circuit reactance of 25% and its rotor has a moment of inertia of 16,800 kg-m². Calculate its natural time period of oscillation. **[1.48 second]**

Maximum Power Output

For given values of terminal voltage, excitation and frequency, there is a maximum power that the alternator is capable of delivering. Fig. 37.103 (a) shows full-load conditions for a cylindrical rotor where IR_a drop has been neglected*.

The power output per phase is

$$P = VI \cos \phi = \frac{VIX_s \cos \phi}{X_s}$$

Now, from Δ OBC, we get

$$\frac{IX_s}{\sin \alpha} = \frac{E}{\sin (90 + \phi)} = \frac{E}{\cos \phi}$$

$$IX_s \cos \phi = E \sin \alpha$$

$$\therefore P = \frac{EV \sin \alpha}{X_s}$$

Power becomes maximum when α = 90°, if V, E and X_s are regarded as constant (of course, E is fixed by excitation).

$$\therefore P_{\max} = EV/X_s$$

It will be seen from Fig. 37.103 (b) that under maximum power output conditions, I leads V by φ and since IX_s leads I by 90°, angle φ and hence cos φ is fixed = E/IX_s.

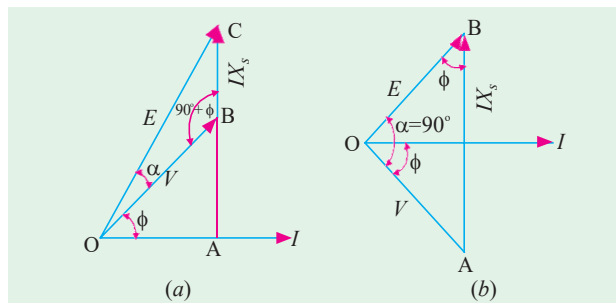

Fig. 37.103

* In fact, this drop can generally be neglected without sacrificing much accuracy of results.

Now, from right-angled $\triangle AOB$, we have that $IX_S = \sqrt{E^2 + V^2}$. Hence, p.f. corresponding to maximum power output is

$$\cos \phi = \frac{E}{\sqrt{E^2 + V^2}}$$

The maximum power output per phase may also be written as

$$P_{\max} = VI_{\max} \cos \phi = VI_{\max} \frac{E}{\sqrt{E^2 + V^2}}$$

where I_{\max} represents the current/phase for maximum power output.

If I_f is the full-load current and $\% X_S$ is the percentage synchronous reactance, then

$$\% X_S = \frac{I_f X_S}{V} \times 100 \quad \therefore \frac{V}{X_S} = \frac{I_f \times 100}{\% X_S}$$

$$\text{Now, } P_{\max} = VI_{\max} \frac{E}{\sqrt{E^2 + V^2}} = \frac{EV}{X_S} = \frac{EI_f \times 100}{\% X_S}$$

Two things are obvious from the above equations.

$$(i) \quad I_{\max} = \frac{100 I_f}{\% X_S} \times \frac{\sqrt{E^2 + V^2}}{V}$$

Substituting the value of $\% X_S$ from above,

$$I_{\max} = \frac{100 I_f}{100 I_f X_S} \times V \times \frac{\sqrt{E^2 + V^2}}{V} = \frac{\sqrt{E^2 + V^2}}{X_S}$$

$$(ii) \quad P_{\max} = \frac{100 EI_f}{\% X_S} = \frac{E}{V} \cdot \frac{100}{\% X_S} \times VI_f \quad \text{per phase}$$

$$= \frac{E}{V} \cdot \frac{100}{\% X_S} \times \text{F.L. power output at u.p.f.}$$

$$\text{Total maximum power output of the alternator is}$$

$$= \frac{E}{V} \cdot \frac{100}{\% X_S} \times \text{F.L. power output at u.p.f.}$$

Example 37.66. Derive the condition for the maximum output of a synchronous generator connected to infinite bus-bars and working at constant excitation.

A 3- ϕ , 11-kV, 5-MVA, Y-connected alternator has a synchronous impedance of $(1 + j 10)$ ohm per phase. Its excitation is such that the generated line e.m.f. is 14 kV. If the alternator is connected to infinite bus-bars, determine the maximum output at the given excitation

(Electrical Machines-III, Gujarat Univ. 1984)

Solution. For the first part, please refer to Art. 37.41

$$P_{\max} \text{ per phase} = \frac{EV}{X_S} \text{ — if } R_a \text{ is neglected} = \frac{V}{Z_S} (E - V \cos \theta) \text{ — if } R_a \text{ is considered}$$

$$\text{Now, } E = 14,000 / \sqrt{3} = 8,083 \text{ V}; V = 11,000 / \sqrt{3} = 6352 \text{ V}$$

$$\cos \theta = R_a / Z_S = 1 / \sqrt{1^2 + 10^2} = 1/10.05$$

$$\therefore P_{\max} \text{ per phase} = \frac{8083 \times 6352}{10 \times 1000} = 5,135 \text{ kW}$$

$$\text{Total } P_{\max} = 3 \times 5,135 = 15,405 \text{ kW}$$

$$\text{More accurately, } P_{\max} / \text{phase} = \frac{6352}{10.05} \left(8083 - \frac{6352}{10.05} \right) = \frac{6352}{10.05} \times \frac{7451}{1000} = 4,711 \text{ kW}$$

$$\text{Total } P_{\max} = 4,711 \times 3 = 14,133 \text{ kW.}$$

Example 37.67. A 3-phase, 11-kVA, 10-MW, Y-connected synchronous generator has synchronous impedance of $(0.8 + j 8.0)$ ohm per phase. If the excitation is such that the open circuit voltage is 14 kV, determine (i) the maximum output of the generator (ii) the current and p.f. at the maximum output.

(Electrical Machines-III, Gujarat Univ. 1987)

Solution. (i) If we neglect R_a^* , the P_{\max} per phase = EV/X_S

where V is the terminal voltage (or bus-bar voltage in general) and E the e.m.f. of the machine.

$$\therefore P_{\max} = \frac{(11,000 / \sqrt{3}) \times (14,000 / \sqrt{3})}{8} = \frac{154,000}{24} \text{ kW/phase}$$

$$\text{Total } P_{\max} = 3 \times 154,000 / 24 = 19,250 \text{ kW} = \mathbf{19.25 \text{ MW}}$$

Incidentally, this output is nearly twice the normal output.

$$\text{(ii) } I_{\max} = \frac{\sqrt{E^2 + V^2}}{X_S} = \frac{\sqrt{[(14,000 / \sqrt{3})^2 + (11,000 / \sqrt{3})^2]}}{8} = \mathbf{1287 \text{ A}}$$

$$\text{(iii) } \text{p.f.} = \frac{E}{\sqrt{E^2 + V^2}} = \frac{14000 / \sqrt{3}}{\sqrt{(14,000 / \sqrt{3})^2 + (11,000 / \sqrt{3})^2}} = \mathbf{0.786 \text{ (lead)}}.$$

QUESTIONS AND ANSWERS ON ALTERNATORS

Q. 1. What are the two types of turbo-alternators ?

Ans. Vertical and horizontal.

Q. 2. How do you compare the two ?

Ans. Vertical type requires less floor space and while step bearing is necessary to carry the weight of the moving element, there is very little friction in the main bearings. The horizontal type requires no step bearing, but occupies more space.

Q. 3. What is step bearing ?

Ans. It consists of two cylindrical cast iron plates which bear upon each other and have a central recess between them. Suitable oil is pumped into this recess under considerable pressure.

Q. 4. What is direct-connected alternator ?

Ans. One in which the alternator and engine are directly connected. In other words, there is no intermediate gearing such as belt, chain etc. between the driving engine and alternator.

Q. 5. What is the difference between direct-connected and direct-coupled units ?

Ans. In the former, alternator and driving engine are directly and permanently connected. In the latter case, engine and alternator are each complete in itself and are connected by some device such as friction clutch, jaw clutch or shaft coupling.

Q. 6. Can a d.c. generator be converted into an alternator ?

Ans. Yes.

Q. 7. How ?

Ans. By providing two collector rings on one end of the armature and connecting these two rings to two points in the armature winding 180° apart.

Q. 8. Would this arrangement result in a desirable alternator ?

Ans. No.

* If R_a is not neglected, then $P_{\max} = \frac{V}{Z_S} (E - V \cos \theta)$ where $\cos \theta = R_a / Z_S$ (Ex. 37.66)

Q. 9. How is a direct-connected exciter arranged in an alternator ?

Ans. The armature of the exciter is mounted on the shaft of the alternator close to the spider hub. In some cases, it is mounted at a distance sufficient to permit a pedestal and bearing to be placed between the exciter and the hub.

Q. 10. Any advantage of a direct-connected exciter ?

Ans. Yes, economy of space.

Q. 11. Any disadvantage ?

Ans. The exciter has to run at the same speed as the alternator which is slower than desirable. Hence, it must be larger for a given output than the gear-driven type, because it can be run at high speed and so made proportionately smaller.

OBJECTIVE TESTS – 37

- The frequency of voltage generated by an alternator having 4-poles and rotating at 1800 r.p.m. is hertz.
 - 60
 - 7200
 - 120
 - 450.
- A 50-Hz alternator will run at the greatest possible speed if it is wound for poles.
 - 8
 - 6
 - 4
 - 2.
- The main disadvantage of using short-pitch winding in alternators is that it
 - reduces harmonics in the generated voltage
 - reduces the total voltage around the armature coils
 - produces asymmetry in the three phase windings
 - increases Cu of end connections.
- Three-phase alternators are invariably Y-connected because
 - magnetic losses are minimised
 - less turns of wire are required
 - smaller conductors can be used
 - higher terminal voltage is obtained.
- The winding of a 4-pole alternator having 36 slots and a coil span of 1 to 8 is short-pitched by degrees.
 - 140
 - 80
 - 20
 - 40.
- If an alternator winding has a fractional pitch of $5/6$, the coil span is degrees.
 - 300
 - 150
 - 30
 - 60.
- The harmonic which would be totally eliminated from the alternator e.m.f. using a fractional pitch of $4/5$ is
 - 3rd
 - 7th
 - 5th
 - 9th.
- For eliminating 7th harmonic from the e.m.f. wave of an alternator, the fractional-pitch must be
 - $2/3$
 - $5/6$
 - $7/8$
 - $6/7$.
- If, in an alternator, chording angle for fundamental flux wave is α , its value for 5th harmonic is
 - 5α
 - $\alpha/5$
 - 25α
 - $\alpha/25$.
- Regarding distribution factor of an armature winding of an alternator which statement is false?
 - it decreases as the distribution of coils (slots/pole) increases
 - higher its value, higher the induced e.m.f. per phase
 - it is not affected by the type of winding either lap, or wave
 - it is not affected by the number of turns per coil.
- When speed of an alternator is changed from 3600 r.p.m. to 1800 r.p.m., the generated e.m.f./phases will become
 - one-half
 - twice
 - four times
 - one-fourth.
- The magnitude of the three voltage drops in an alternator due to armature resistance, leakage reactance and armature reaction is solely determined by
 - load current, I_a

- (b) p.f. of the load
 (c) whether it is a lagging or leading p.f. load
 (d) field construction of the alternator.
13. Armature reaction in an alternator primarily affects
 (a) rotor speed
 (b) terminal voltage per phase
 (c) frequency of armature current
 (d) generated voltage per phase.
14. Under no-load condition, power drawn by the prime mover of an alternator goes to
 (a) produce induced e.m.f. in armature winding
 (b) meet no-load losses
 (c) produce power in the armature
 (d) meet Cu losses both in armature and rotor windings.
15. As load p.f. of an alternator becomes more leading, the value of generated voltage required to give rated terminal voltage
 (a) increases
 (b) remains unchanged
 (c) decreases
 (d) varies with rotor speed.
16. With a load p.f. of unity, the effect of armature reaction on the main-field flux of an alternator is
 (a) distortional (b) magnetising
 (c) demagnetising (d) nominal.
17. At lagging loads, armature reaction in an alternator is
 (a) cross-magnetising (b) demagnetising
 (c) non-effective (d) magnetising.
18. At leading p.f., the armature flux in an alternator the rotor flux.
 (a) opposes (b) aids
 (c) distorts (d) does not affect.
19. The voltage regulation of an alternator having 0.75 leading p.f. load, no-load induced e.m.f. of 2400V and rated terminal voltage of 3000V is percent.
 (a) 20 (b) - 20
 (c) 150 (d) - 26.7
20. If, in a 3- ϕ alternator, a field current of 50A produces a full-load armature current of 200 A on short-circuit and 1730 V on open circuit, then its synchronous impedance is ohm.
 (a) 8.66 (b) 4
 (c) 5 (d) 34.6
21. The power factor of an alternator is determined by its
 (a) speed
 (b) load
 (c) excitation
 (d) prime mover.
22. For proper parallel operation, a.c. polyphase alternators must have the same
 (a) speed (b) voltage rating
 (c) kVA rating (d) excitation.
23. Of the following conditions, the one which does not have to be met by alternators working in parallel is
 (a) terminal voltage of each machine must be the same
 (b) the machines must have the same phase rotation
 (c) the machines must operate at the same frequency
 (d) the machines must have equal ratings.
24. After wiring up two 3- ϕ alternators, you checked their frequency and voltage and found them to be equal. Before connecting them in parallel, you would
 (a) check turbine speed
 (b) check phaserotation
 (c) lubricate everything
 (d) check steam pressure.
25. Zero power factor method of an alternator is used to find its
 (a) efficiency
 (b) voltage regulation
 (c) armature resistance
 (d) synchronous impedance.
26. Some engineers prefer 'lamps bright' synchronization to 'lamps dark' synchronization because
 (a) brightness of lamps can be judged easily
 (b) it gives sharper and more accurate synchronization
 (c) flicker is more pronounced
 (d) it can be performed quickly.
27. It is never advisable to connect a stationary alternator to live bus-bars because it
 (a) is likely to run as synchronous motor
 (b) will get short-circuited
 (c) will decrease bus-bar voltage though momentarily
 (d) will disturb generated e.m.fs. of other alternators connected in parallel.

28. Two identical alternators are running in parallel and carry equal loads. If excitation of one alternator is increased without changing its steam supply, then
- it will keep supplying almost the same load
 - kVAR supplied by it would decrease
 - its p.f. will increase
 - kVA supplied by it would decrease.
29. Keeping its excitation constant, if steam supply of an alternator running in parallel with another identical alternator is increased, then
- it would over-run the other alternator
 - its rotor will fall back in phase with respect to the other machine
 - it will supply greater portion of the load
 - its power factor would be decreased.
30. The load sharing between two steam-driven alternators operating in parallel may be adjusted by varying the
- field strengths of the alternators
 - power factors of the alternators
 - steam supply to their prime movers
 - speed of the alternators.
31. Squirrel-cage bars placed in the rotor pole faces of an alternator help reduce hunting
- above synchronous speed only
 - below synchronous speed only
 - above and below synchronous speeds both
 - none of the above.
- (Elect. Machines, A.M.I.E. Sec. B, 1993)
32. For a machine on infinite bus active power can be varied by
- changing field excitation
 - changing of prime mover speed
 - both (a) and (b) above
 - none of the above .
- (Elect. Machines, A.M.I.E. Sec. B, 1993)

ANSWERS

1. <i>a</i>	2. <i>d</i>	3. <i>b</i>	4. <i>d</i>	5. <i>d</i>	6. <i>b</i>	7. <i>c</i>	8. <i>d</i>	9. <i>a</i>	10. <i>b</i>	11. <i>a</i>
12. <i>a</i>	13. <i>d</i>	14. <i>b</i>	15. <i>c</i>	16. <i>a</i>	17. <i>d</i>	18. <i>b</i>	19. <i>b</i>	20. <i>c</i>	21. <i>b</i>	22. <i>b</i>
23. <i>d</i>	24. <i>b</i>	25. <i>b</i>	26. <i>b</i>	27. <i>b</i>	28. <i>a</i>	29. <i>c</i>	30. <i>c</i>	31. <i>c</i>	32. <i>b</i>	