

# CHAPTER 10

## Learning Objectives

Working Principle of Transformer  
Transformer Construction  
Core-type Transformers  
Shell-type Transformers  
E.M.F. Equation of Transformer  
Voltage Transformation Ratio  
Transformer with losses  
Equivalent Resistance  
Magnetic Leakage  
Transformer with Resistance and Leakage Reactance  
Total Approximate Voltage Drop in Transformer  
Exact Voltage Drop  
Separation of Core Losses  
Short-Circuit or Impedance Test  
Why Transformer Rating in KVA?  
Regulation of a Transformer  
Percentage Resistance, Reactance and Impedance  
Kapp Regulation Diagram  
Sumpner or Back-to-back-Test  
Efficiency of a Transformer  
Auto-transformer

## TRANSFORMER



**T** To overcome losses, the electricity from a generator is passed through a step-up transformer, which increases the voltage. Throughout the distribution system, the voltages are changed using step-down transformers to voltages suitable to the applications at industry and homes.

### Working Principle of a Transformer

A transformer is a static (or stationary) piece of apparatus by means of which electric power in one circuit is transformed into electric power of the same frequency in another circuit. It can raise or lower the voltage in a circuit but with a corresponding decrease or increase in current. The physical basis of a transformer is *mutual induction* between two circuits linked by a common magnetic flux. In its simplest form, it consists of two inductive coils which are electrically separated but magnetically linked through a path of low reluctance as shown in Fig. 32.1. The two coils possess high mutual inductance. If one coil is connected to a source of alternating voltage, an alternating flux is set up in the laminated core, most of which is linked with the other coil in which it produces mutually-induced e.m.f. (according to Faraday’s Laws of Electromagnetic Induction  $e = Mdi/dt$ ). If the second coil circuit is closed, a current flows in it and so electric energy is transferred (entirely magnetically) from the first coil to the second coil. The first coil, in which electric energy is fed from the a.c. supply mains, is called *primary* winding and the other from which energy is drawn out, is called *secondary* winding. In brief, a transformer is a device that

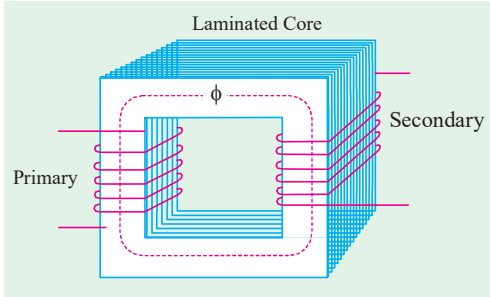

Fig. 32.1

1. transfers electric power from one circuit to another
2. it does so without a change of frequency
3. it accomplishes this by electromagnetic induction and
4. where the two electric circuits are in mutual inductive influence of each other.

### Transformer Construction

The simple elements of a transformer consist of two coils having mutual inductance and a laminated steel core. The two coils are insulated from each other and the steel core. Other necessary parts are : some suitable container for assembled core and windings ; a suitable medium for insulating the core and its windings from its container ; suitable bushings (either of porcelain, oil-filled or capacitor-type) for insulating and bringing out the terminals of windings from the tank.

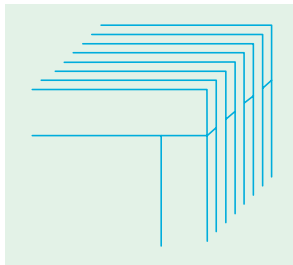
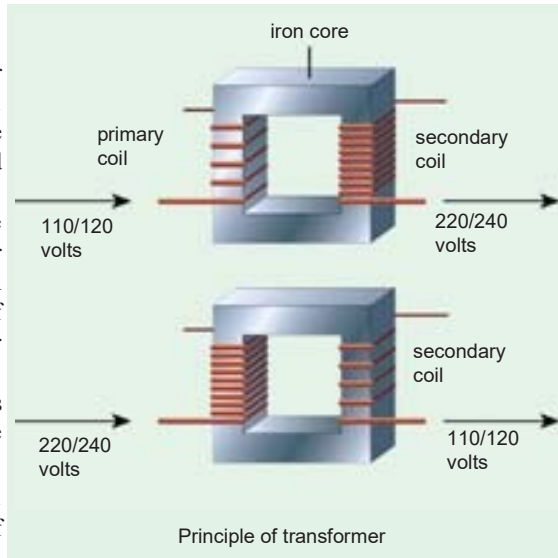

Fig. 32.2

In all types of transformers,

the core is constructed of transformer sheet steel laminations assembled to provide a continuous magnetic path with a minimum of air-gap included. The steel used is of high silicon content, sometimes heat treated to produce a high permeability and a low hysteresis loss at the



usual operating flux densities. The eddy current loss is minimised by laminating the core, the laminations being insulated from each other by a light coat of core-plate varnish or by an oxide layer on the surface. The thickness of laminations varies from 0.35 mm for a frequency of 50 Hz to 0.5 mm for a frequency of 25 Hz. The core laminations (in the form of strips) are joined as shown in Fig. 32.2. It is seen that the joints in the alternate layers are staggered in order to avoid the presence of narrow gaps right through the cross-section of the core. Such staggered joints are said to be 'imbricated'.

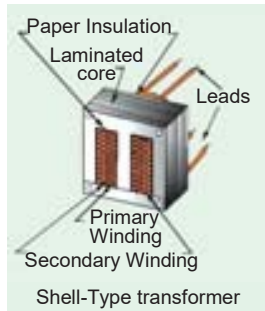

Constructionally, the transformers are of two general types, distinguished from each other merely by the manner in which the primary and secondary coils are placed around the laminated core. The two types are known as (i) core-type and (ii) shell-type. Another recent development is spiral-core or wound-core type, the trade name being spirakore transformer.

In the so-called core type transformers, the windings surround a considerable part of the core whereas in shell-type transformers, the core surrounds a considerable portion of the windings as shown schematically in Fig. 32.3 (a) and (b) respectively.

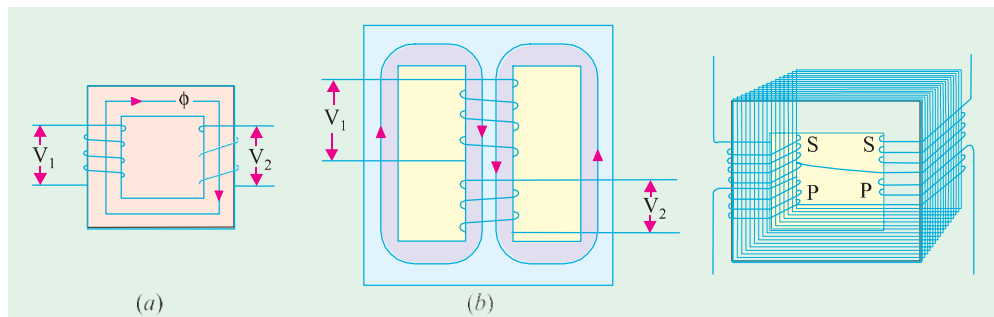
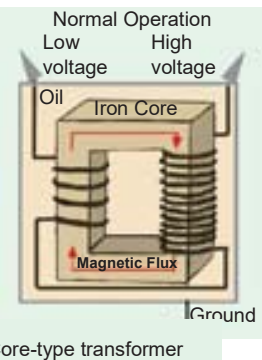

Fig. 32.3

Fig. 32.4

In the simplified diagram for the core type transformers [Fig. 32.3 (a)], the primary and secondary winding are shown located on the opposite legs (or limbs) of the core, but in actual construction, these are always interleaved to reduce leakage flux. As shown in Fig. 32.4, half the primary and half the secondary winding have been placed side by side or concentrically on each limb, not primary on one limb (or leg) and the secondary on the other.

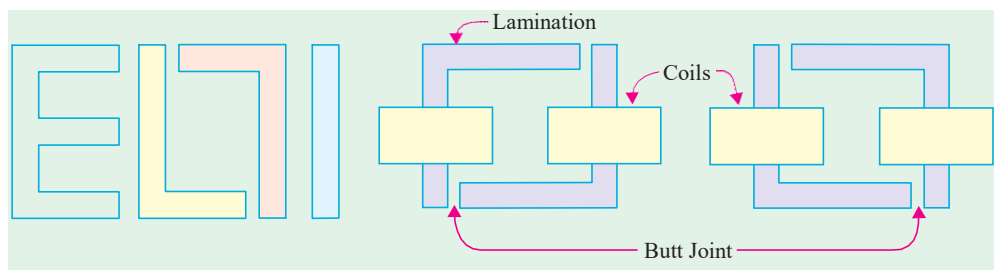

Fig. 32.5

Fig. 32.6

In both core and shell-type transformers, the individual laminations are cut in the form of long strips of L's, E's and P's as shown in Fig. 32.5. The assembly of the complete core for the two types of transformers is shown in Fig. 32.6 and Fig. 32.7.

As said above, in order to avoid high reluctance at the joints where the laminations are butted against each other, the alternate layers are stacked differently to eliminate these joints as shown in Fig. 32.6 and Fig. 32.7.

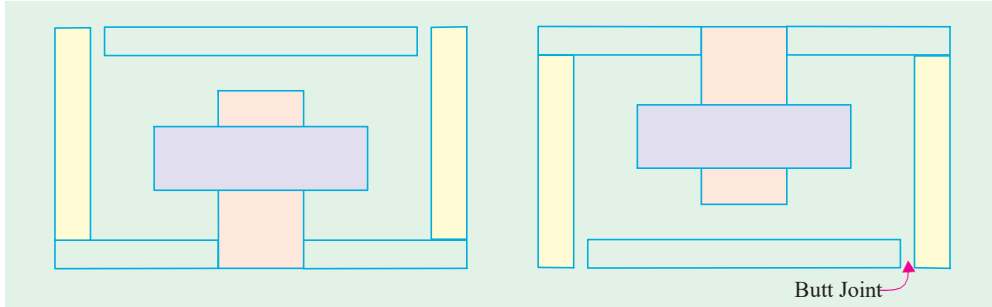

Fig. 32.7

### Core-type Transformers

The coils used are form-wound and are of the cylindrical type. The general form of these coils may be circular or oval or rectangular. In small size core-type transformers, a simple rectangular core is used with cylindrical coils which are either circular or rectangular in form. But for large-size core-type transformers, round

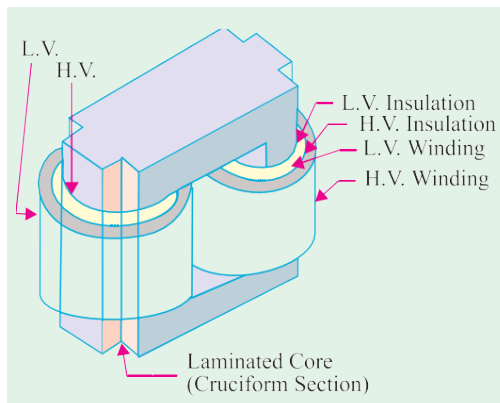
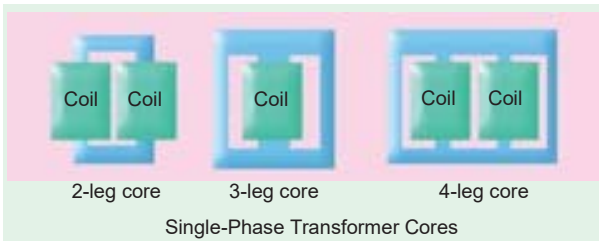

Fig. 32.8 (a)

or circular cylindrical coils are used which are so wound as to fit over a cruciform core section as shown in Fig. 32.8(a). The circular cylindrical coils are used in most of the core-type transformers because of their mechanical strength. Such cylindrical coils are wound in helical layers with the different layers insulated from each other by paper, cloth, mica board or cooling ducts. Fig. 32.8(c) shows the general arrangement of these coils with respect to the core. Insulating cylinders of fuller board are used to separate the cylindrical windings from the core and from each other. Since the low-voltage (LV) winding is easiest to insulate, it is placed nearest to the core (Fig. 32.8).

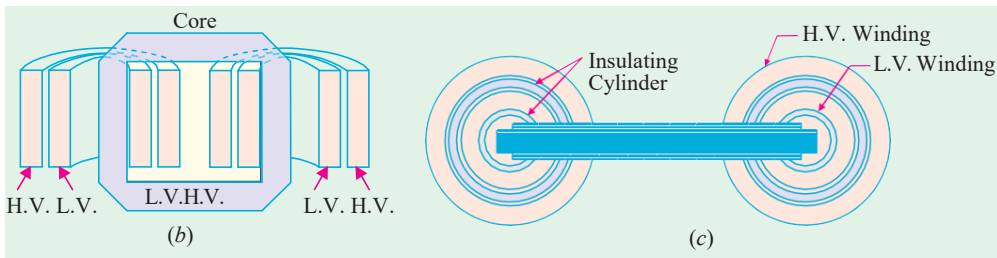

Fig. 32.8

Because of laminations and insulation, the net or effective core area is reduced, due allowance for which has to be made (Ex. 32.6). It is found that, in general, the reduction in core sectional area due to the presence of paper, surface oxide etc. is of the order of 10% approximately.

As pointed out above, rectangular cores with rectangular cylindrical coils can be used for small-size core-type transformers as shown in Fig. 32.9 (a) but for large-sized transformers, it becomes wasteful to use rectangular cylindrical coils and so circular cylindrical coils are preferred. For such purposes, square cores may be used as shown in Fig. 32.9 (b) where circles represent the tubular former carrying the coils. Obviously, a considerable amount of useful space is still wasted. A common improvement on square core is to employ cruciform core as in Fig. 32.9 (c) which demands, at least, two sizes of core strips. For very large transformers, further core-stepping is done as in Fig. 32.9 (d) where at least three sizes of core plates are necessary. Core-stepping not only gives high space factor but also results in reduced length of the mean turn and the consequent  $I^2R$  loss. Three stepped core is the one most commonly used although more steps may be used for very large transformers as in Fig. 32.9 (e). From the geometry of Fig. 32.9, it can be shown that maximum gross core section for Fig. 32.9 (b) is  $0.5 d^2$  and for Fig. 32.9 (c) it is  $0.616 d^2$  where  $d$  is the diameter of the cylindrical coil.

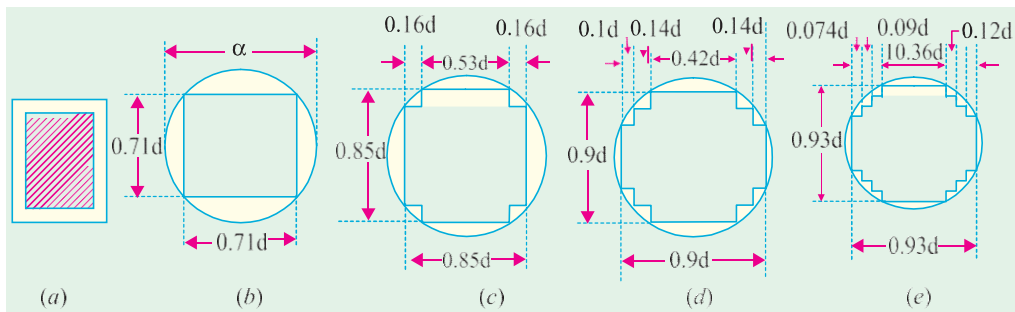

Fig. 32.9

### Shell-type Transformers

In these case also, the coils are form-wound but are multi-layer disc type usually wound in the form of pancakes. The different layers of such multi-layer discs are insulated from each other by paper. The complete winding consists of stacked discs with insulation space between the coils—the spaces forming horizontal cooling and insulating ducts. A shell-type transformer may have a simple rectangular form as shown in Fig. 32.10 or it may have distributed form as shown in Fig. 32.11.

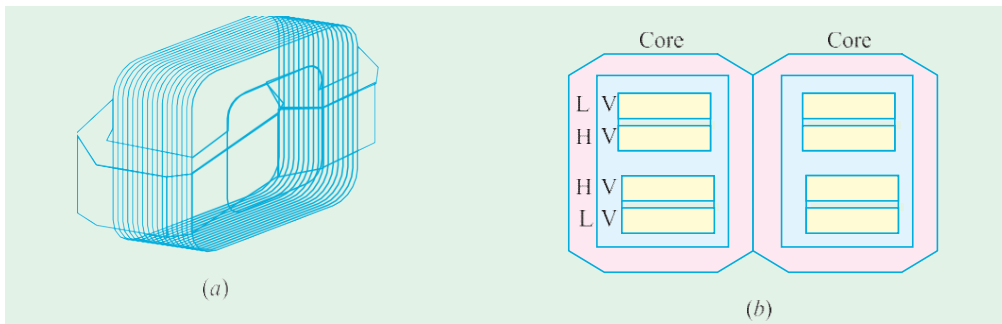

Fig. 32.10

A very commonly-used shell-type transformer is the one known as Berry Transformer—so called after the name of its designer and is cylindrical in form. The transformer core consists of laminations arranged in groups which radiate out from the centre as shown in section in Fig. 32.12.

It may be pointed out that cores and coils of transformers must be provided with rigid mechanical bracing in order to prevent movement and possible insulation damage. Good bracing reduces vibration and the objectionable noise—a humming sound—during operation.

The spiral-core transformer employs the newest development in core construction. The core is assembled of a continuous strip or ribbon of transformer steel wound in the form of a circular or elliptical cylinder. Such construction allows the core flux to follow the grain of the iron. Cold-rolled steel of high silicon content enables the designer to use considerably higher operating flux densities with lower loss per kg. The use of higher flux density reduces the weight per kVA. Hence, the advantages of such construction are (i) a relatively more rigid core (ii) lesser weight and size per kVA rating (iii) lower iron losses at higher operating flux densities and (iv) lower cost of manufacture.

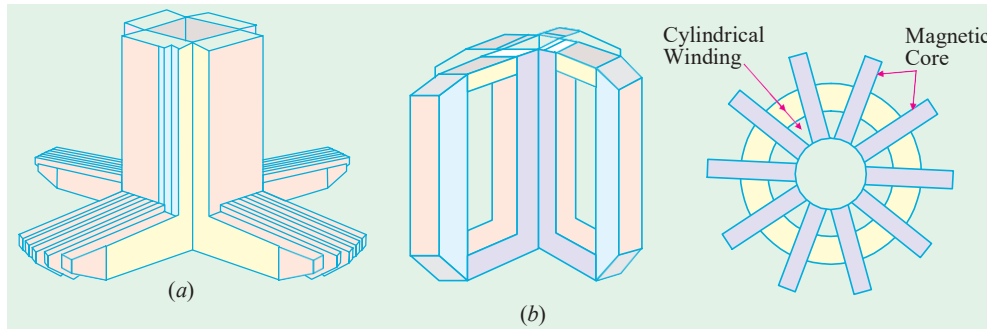

Fig. 32.11

Fig. 32.12

Transformers are generally housed in tightly-fitted sheet-metal tanks filled with special insulating oil\*. This oil has been highly developed and its function is two-fold. By circulation, it not only keeps the coils reasonably cool, but also provides the transformer with additional insulation not obtainable when the transformer is left in the air.

In cases where a smooth tank surface does not provide sufficient cooling area, the sides of the tank are corrugated or provided with radiators mounted on the sides. Good transformer oil should be absolutely free from alkalis, sulphur and particularly from moisture. The presence of even an extremely small percentage of moisture in the oil is highly detrimental from the insulation viewpoint because it lowers the dielectric strength of the oil considerably. The importance of avoiding moisture in the transformer oil is clear from the fact that even an addition of 8 parts of water in 1,000,000 reduces the insulating quality of the oil to a value generally recognized as below standard. Hence, the tanks are sealed air-tight in smaller units. In the case of large-sized transformers where complete air-tight construction is impossible, chambers known as *breathers* are provided to permit the oil inside the tank to expand and contract as its temperature increases or decreases. The atmospheric moisture is entrapped in these breathers and is not allowed to pass on to the oil. Another thing to avoid in the oil is slegging which is simply the decomposition of oil with long and continued use. Slegging is caused principally by exposure to oxygen during heating and results in the formation of large deposits of dark and heavy matter that eventually clogs the cooling ducts in the transformer.

No other feature in the construction of a transformer is given more attention and care than the insulating materials, because the life on the unit almost solely depends on the quality, durability and handling of these materials. All the insulating materials are selected on the basis of their high quality and ability to preserve high quality even after many years of normal use.

\* Instead of natural mineral oil, now-a-days synthetic insulating fluids known as ASKARELS (trade name) are used. They are non-inflammable and, under the influence of an electric arc, do not decompose to produce inflammable gases. One such fluid commercially known as PYROCLOR is being extensively used because it possesses remarkable stability as a dielectric and even after long service shows no deterioration through slegging, oxidation, acid or moisture formation. Unlike mineral oil, it shows no rapid burning.

All the transformer leads are brought out of their cases through suitable bushings. There are many designs of these, their size and construction depending on the voltage of the leads. For moderate voltages, porcelain bushings are used to insulate the leads as they come out through the tank. In general, they look almost like the insulators used on the transmission lines. In high voltage installations, oil-filled or capacitor-type bushings are employed.

The choice of core or shell-type construction is usually determined by cost, because similar characteristics can be obtained with both types. For very high-voltage transformers or for multiwinding design, shell-type construction is preferred by many manufacturers. In this type, usually the mean length of coil turn is longer than in a comparable core-type design. Both core and shell forms are used and the selection is decided by many factors such as voltage rating, kVA rating, weight, insulation stress, heat distribution etc.

Another means of classifying the transformers is according to the type of cooling employed. The following types are in common use :

(a) *oil-filled self-cooled*      (b) *oil-filled water-cooled*      (c) *air-blast type*

Small and medium size distribution transformers—so called because of their use on distribution systems as distinguished from line transmission—are of type (a). The assembled windings and cores of such transformers are mounted in a welded, oil-tight steel tank provided with steel cover. After putting the core at its proper place, the tank is filled with purified, high quality insulating oil. The oil serves to convey the heat from the core and the windings to the case from where it is radiated out to the surroundings. For small size, the tanks are usually smooth-surfaced, but for larger sizes, the cases are frequently corrugated or fluted to get greater heat radiation area without increasing the cubical capacity of the tank. Still larger sizes are provided with radiators or pipes.

Construction of very large self-cooled transformers is expensive, a more economical form of construction for such large transformers is provided in the oil-immersed, water-cooled type. As before, the windings and the core are immersed in the oil, but there is mounted near the surface of oil, a cooling coil through which cold water is kept circulating. The heat is carried away by this water. The largest transformers such as those used with high-voltage transmission lines, are constructed in this manner.

Oil-filled transformers are built for outdoor duty and as these require no housing other than their own, a great saving is thereby effected. These transformers require only periodic inspection.

For voltages below 25,000 V, transformers can be built for cooling by means of an air-blast. The transformer is not immersed in oil, but is housed in a thin sheet-metal box open at both ends through which air is blown from the bottom to the top by means of a fan or blower.

### Elementary Theory of an Ideal Transformer

An ideal transformer is one which has no losses *i.e.* its windings have no ohmic resistance, there is no magnetic leakage and hence which has no  $I^2R$  and core losses. In other words, an ideal transformer consists of two purely inductive coils wound on a loss-free core. It may, however, be noted *that it is impossible to realize such a transformer in practice, yet for convenience, we will start with such a transformer and step by step approach an actual transformer.*

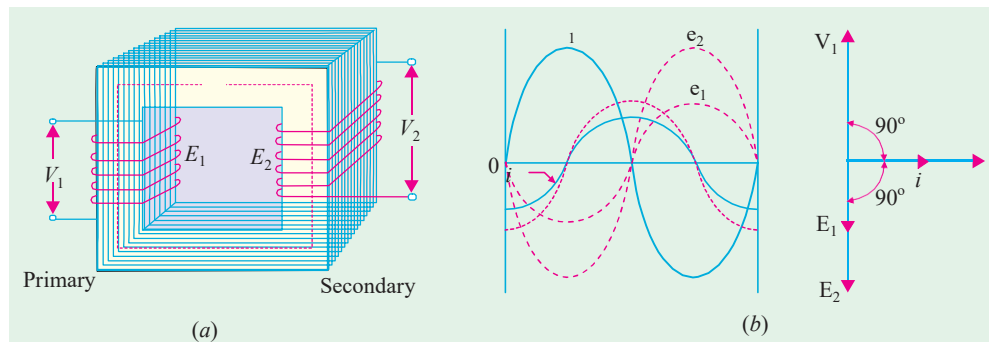

Fig. 32.13

Consider an ideal transformer [Fig. 32.13 (a)] whose secondary is open and whose primary is connected to sinusoidal alternating voltage  $V_1$ . This potential difference causes an alternating current to flow in the primary. Since the primary coil is purely inductive and there is no output (secondary being open) the primary draws the magnetising current  $I_\mu$  only. The function of this current is merely to magnetise the core, it is small in magnitude and lags  $V_1$  by  $90^\circ$ . This alternating current  $I_\mu$  produces an alternating flux  $\phi$  which is, at all times, proportional to the current (assuming permeability of the magnetic circuit to be constant) and, hence, is in phase with it. This changing flux is linked both with the primary and the secondary windings. Therefore, it produces self-induced e.m.f. in the primary. This *self-induced* e.m.f.  $E_1$  is, at every instant, equal to and in opposition to  $V_1$ . It is also known as counter e.m.f. or back e.m.f. of the primary.

Similarly, there is produced in the secondary an induced e.m.f.  $E_2$  which is known as *mutually* induced e.m.f. This e.m.f. is antiphase with  $V_1$  and its magnitude is proportional to the rate of change of flux and the number of secondary turns.

The instantaneous values of applied voltage, induced e.m.fs, flux and magnetising current are shown by sinusoidal waves in Fig. 32.13 (b). Fig. 32.13

(c) shows the vectorial representation of the effective values of the above quantities.

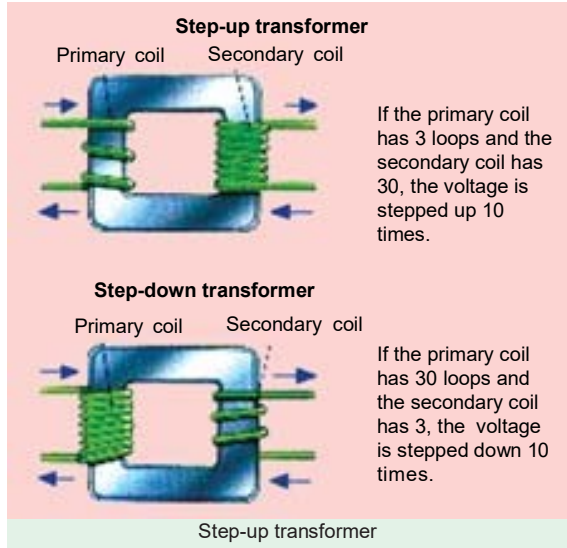

**E.M.F. Equation of a Transformer**

- Let  $N_1$  = No. of turns in primary
- $N_2$  = No. of turns in secondary
- $\Phi_m$  = Maximum flux in core in webers  
=  $B_m \times A$
- $f$  = Frequency of a.c. input in Hz

As shown in Fig. 32.14, flux increases from its zero value to maximum value  $\Phi_m$  in one quarter of the cycle *i.e.* in  $1/4f$  second.

$$\therefore \text{Average rate of change of flux} = \frac{\Phi_m}{1/4f}$$

$$= 4f\Phi_m \text{ Wb/s or volt}$$

Now, rate of change of flux per turn means induced e.m.f. in volts.

$$\therefore \text{Average e.m.f./turn} = 4f\Phi_m \text{ volt}$$

If flux  $\Phi$  varies *sinusoidally*, then r.m.s. value of induced e.m.f. is obtained by multiplying the average value with form factor.

$$\text{Form factor} = \frac{\text{r.m.s. value}}{\text{average value}} = 1.11$$

$$\therefore \text{r.m.s. value of e.m.f./turn} = 1.11 \times 4f\Phi_m = 4.44f\Phi_m \text{ volt}$$

Now, r.m.s. value of the induced e.m.f. in the whole of primary winding

$$= (\text{induced e.m.f./turn}) \times \text{No. of primary turns}$$

$$E_1 = 4.44fN_1\Phi_m = 4.44fN_1B_mA \quad \dots(i)$$

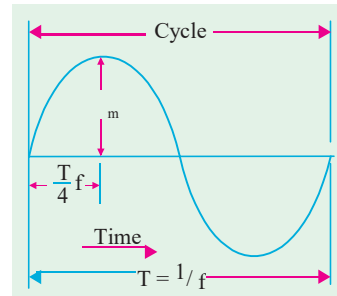

Fig. 32.14



Similarly, r.m.s. value of the e.m.f. induced in secondary is,

$$E_2 = 4.44 f N_2 \Phi_m = 4.44 f N_2 B_m A \quad \dots(ii)$$

It is seen from (i) and (ii) that  $E_1/N_1 = E_2/N_2 = 4.44 f \Phi_m$ . It means that e.m.f./turn is the same in both the primary and secondary windings.

In an ideal transformer on no-load,  $V_1 = E_1$  and  $E_2 = V_2$  where  $V_2$  is the terminal voltage (Fig. 32.15).

### 32.7 Voltage Transformation Ratio (K)

From equations (i) and (ii), we get

$$\frac{E_2}{E_1} = \frac{N_2}{N_1} = K$$

This constant  $K$  is known as voltage transformation ratio.

(i) If  $N_2 > N_1$  i.e.  $K > 1$ , then transformer is called **step-up** transformer.

(ii) If  $N_2 < N_1$  i.e.  $K < 1$ , then transformer is known as **step-down** transformer.

Again, for an ideal transformer, input  $VA =$  output  $VA$ .

$$V_1 I_1 = V_2 I_2 \text{ or } \frac{I_2}{I_1} = \frac{V_1}{V_2} = \frac{1}{K}$$

Hence, currents are in the inverse ratio of the (voltage) transformation ratio.

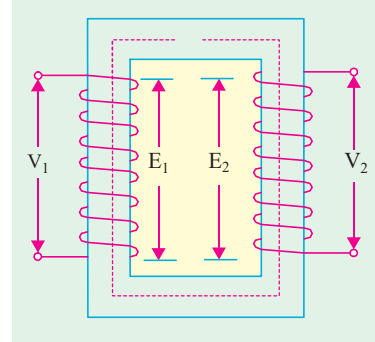

Fig. 32.15

**Example 32.1.** The maximum flux density in the core of a 250/3000-volts, 50-Hz single-phase transformer is  $1.2 \text{ Wb/m}^2$ . If the e.m.f. per turn is 8 volt, determine

(i) primary and secondary turns (ii) area of the core.

(Electrical Engg.-I, Nagpur Univ. 1991)

**Solution. (i)**  $E_1 = N_1 \times \text{e.m.f. induced/turn}$   
 $N_1 = 250/8 = 32$ ;  $N_2 = 3000/8 = 375$

(ii) We may use  $E_2 = -4.44 f N_2 B_m A$   
 $\therefore 3000 = 4.44 \times 50 \times 375 \times 1.2 \times A$ ;  $A = 0.03 \text{ m}^2$

**Example 32.2.** The core of a 100-kVA, 11000/550 V, 50-Hz, 1-ph, core type transformer has a cross-section of  $20 \text{ cm} \times 20 \text{ cm}$ . Find (i) the number of H.V. and L.V. turns per phase and (ii) the e.m.f. per turn if the maximum core density is not to exceed 1.3 Tesla. Assume a stacking factor of 0.9.

What will happen if its primary voltage is increased by 10% on no-load?

(Elect. Machines, A.M.I.E. Sec. B, 1991)

**Solution. (i)**  $B_m = 1.3 \text{ T}$ ,  $A = (0.2 \times 0.2) \times 0.9 = 0.036 \text{ m}^2$   
 $\therefore 11,000 = 4.44 \times 50 \times N_1 \times 1.3 \times 0.036$ ,  $N_1 = 1060$   
 $550 = 4.44 \times 50 \times N_2 \times 1.3 \times 0.036$ ;  $N_2 = 53$

or,  $N_2 = K N_1 = (550/11,000) \times 1060 = 53$   
 (ii) e.m.f./turn =  $11,000/1060 = 10.4 \text{ V}$  or  $550/53 = 10.4 \text{ V}$

Keeping supply frequency constant, if primary voltage is increased by 10%, magnetising current will increase by much more than 10%. However, due to saturation, flux density will increase only marginally and so will the eddy current and hysteresis losses.

**Example 32.3.** A single-phase transformer has 400 primary and 1000 secondary turns. The net cross-sectional area of the core is  $60 \text{ cm}^2$ . If the primary winding be connected to a 50-Hz supply at 520 V, calculate (i) the peak value of flux density in the core (ii) the voltage induced in the secondary winding.  
 (Elect. Engg.-I, Pune Univ. 1989)

**Solution.**

$$K = N_2/N_1 = 1000/400 = 2.5$$

$$(i) \quad E_2/E_1 = K \quad \therefore E_2 = KE_1 = 2.5 \times 520 = \mathbf{1300 \text{ V}}$$

$$(ii) \quad E_1 = 4.44 f N_1 B_m A$$

$$\text{or} \quad 520 = 4.44 \times 50 \times 400 \times B_m \times (60 \times 10)^{-4} \quad \therefore B_m = \mathbf{0.976 \text{ Wb/m}^2}$$

**Example 32.4.** A 25-kVA transformer has 500 turns on the primary and 50 turns on the secondary winding. The primary is connected to 3000-V, 50-Hz supply. Find the full-load primary and secondary currents, the secondary e.m.f. and the maximum flux in the core. Neglect leakage drops and no-load primary current. **(Elect. & Electronic Engg., Madras Univ. 1985)**

**Solution.**

$$K = N_2/N_1 = 50/500 = 1/10$$

$$\text{Now, full-load} \quad I_1 = 25,000/3000 = \mathbf{8.33 \text{ A}}. \quad \text{F.L. } I_2 = I_1/K = 10 \times 8.33 = \mathbf{83.3 \text{ A}}$$

$$\text{e.m.f. per turn on primary side} = 3000/500 = 6 \text{ V}$$

$$\therefore \quad \text{secondary e.m.f.} = 6 \times 50 = \mathbf{300 \text{ V}} \quad (\text{or } E_2 = KE_1 = 3000 \times 1/10 = 300 \text{ V})$$

$$\text{Also,} \quad E_1 = 4.44 f N_1 \Phi_m; \quad 3000 = 4.44 \times 50 \times 500 \times \Phi_m \quad \therefore \Phi_m = \mathbf{27 \text{ mWb}}$$

**Example 32.5.** The core of a three phase, 50 Hz, 11000/550 V delta/star, 300 kVA, core-type transformer operates with a flux of 0.05 Wb. Find

(i) number of H.V. and L.V. turns per phase. (ii) e.m.f. per turn

(iii) full load H.V. and L.V. phase-currents. **(Bharathidasan Univ. April 1997)**

**Solution.** Maximum value of flux has been given as 0.05 Wb.

$$(ii) \quad \text{e.m.f. per turn} = 4.44 f \Phi_m \\ = 4.44 \times 50 \times 0.05 = 11.1 \text{ volts}$$

(i) Calculations for number of turns on two sides :

$$\text{Voltage per phase on delta-connected primary winding} = 11000 \text{ volts}$$

$$\text{Voltage per phase on star-connected secondary winding} = 550/1.732 = 317.5 \text{ volts}$$

$$T_1 = \text{number of turns on primary, per phase} \\ = \text{voltage per phase/e.m.f. per turn} \\ = 11000/11.1 = 991$$

$$T_2 = \text{number of turns on secondary, per phase} \\ = \text{voltage per phase/e.m.f. per turn} \\ = 317.5/11.1 = 28.6$$

**Note :** (i) Generally, Low-voltage-turns are calculated first, the figure is rounded off to next higher even integer. In this case, it will be 30. Then, number of turns on primary side is calculated by turns-ratio.

$$\text{In this case,} \quad T_1 = T_2 (V_1/V_2) = 30 \times 11000/317.5 = 1040$$

This, however, reduces the flux and results into less saturation. This, in fact, is an elementary aspect in Design-calculations for transformers. (Explanation is added here only to overcome a doubt whether a fraction is acceptable as a number of L.V. turns).

(ii) Full load H.V. and L.V. phase currents :

$$\text{Output per phase} = (300/3) = 100 \text{ kVA}$$

$$\text{H.V. phase-current} = \frac{100 \times 1000}{11,000} = 9.1 \text{ Amp}$$

$$\text{L.V. phase-current} = (100 \times 1000/317.5) = 315 \text{ Amp}$$

**Example 32.6.** A single phase transformer has 500 turns in the primary and 1200 turns in the secondary. The cross-sectional area of the core is 80 sq. cm. If the primary winding is connected to a 50 Hz supply at 500 V, calculate (i) Peak flux-density, and (ii) Voltage induced in the secondary.

**(Bharathiar University November 1997)**

**Solution.** From the e.m.f. equation for transformer,

$$500 = 4.44 \times 50 \times \phi_m \times 500$$

$$\phi_m = 1/222 \text{ Wb}$$

(i) Peak flux density,  $B_m = \phi_m / (80 \times 10^{-4}) = 0.563 \text{ wb/m}^2$

(ii) Voltage induced in secondary is obtained from transformation ratio or turns ratio

$$\frac{V_2}{V_1} = \frac{N_2}{N_1}$$

or  $V_2 = 500 \times 1200/500 = 1200 \text{ volts}$

**Example 32.7.** A 25 kVA, single-phase transformer has 250 turns on the primary and 40 turns on the secondary winding. The primary is connected to 1500-volt, 50 Hz mains. Calculate (i) Primary and Secondary currents on full-load, (ii) Secondary e.m.f., (iii) maximum flux in the core.

(Bharathiar Univ. April 1998)

**Solution. (i)** If  $V_2 =$  Secondary voltage rating, = secondary e.m.f.,

$$\frac{V_2}{1500} = \frac{40}{250} \text{ giving } V_2 = 240 \text{ volts}$$

(ii) Primary current =  $25000/1500 = 16.67 \text{ amp}$   
Secondary current =  $25000/240 = 104.2 \text{ amp}$

(iii) If  $\phi_m$  is the maximum core-flux in Wb,

$$1500 = 4.44 \times 50 \times \phi_m \times 250, \text{ giving } \phi_m = 0.027 \text{ Wb or } 27 \text{ mWb}$$

**Example 32.8.** A single-phase, 50 Hz, core-type transformer has square cores of 20 cm side. Permissible maximum flux-density is 1 Wb/m<sup>2</sup>. Calculate the number of turns per Limb on the High and Low-voltage sides for a 3000/220 V ratio. (Manonmaniam Sundaranar Univ. April 1998)

**Solution.** E.M.F. equation gives the number of turns required on the two sides. We shall first calculate the L.V.-turns, round the figure off to the next higher even number, so that given maximum flux density is not exceeded. With the corrected number of L.V. turns, calculate H.V.-turns by transformation ratio. Further, there are two Limbs. Each Limb accommodates half-L.V. and half-H.V. winding from the view-point of reducing leakage reactance.

Starting with calculation for L.V. turns,  $T_2$ ,

$$4.44 \times 50 \times [(20 \times 20 \times 10^{-4}) \times 1] \times T_2 = 220$$

$$T_2 = 220/8.88 = 24.77$$

Select  $T_2 = 26$

$$T_1/T_2 = V_1/V_2$$

$$T_1 = 26 \times 3000/220 = 354, \text{ selecting the nearest even integer.}$$

Number of H.V. turns on each Limb = 177

Number of L.V. turns on each Limb = 13

### Transformer with Losses but no Magnetic Leakage

We will consider two cases (i) when such a transformer is on no load and (ii) when it is loaded.

#### Transformer on No-load

In the above discussion, we assumed an ideal transformer *i.e.* one in which there were no core losses and copper losses. But practical conditions require that certain modifications be made in the foregoing

theory. When an **actual** transformer is put on load, there is iron loss in the core and copper loss in the windings (both primary and secondary) and these losses are not entirely negligible.

Even when the transformer is on no-load, the primary input current is not wholly reactive. The primary input current under no-load conditions has to supply (i) iron losses in the core *i.e.* hysteresis loss and eddy current loss and (ii) a very small amount of copper loss in primary (there being no Cu loss in secondary as it is open). Hence, the no-load primary input current  $I_0$  is not at  $90^\circ$  behind  $V_1$  but lags it by an angle  $\phi_0 < 90^\circ$ . No-load input power

$$W_0 = V_1 I_0 \cos \phi_0$$

where  $\cos \phi_0$  is primary power factor under no-load conditions. No-load condition of an actual transformer is shown vectorially in Fig. 32.16.

As seen from Fig. 32.16, primary current  $I_0$  has two components :

(i) One in phase with  $V_1$ . This is known as **active** or **working** or **iron** loss component  $I_w$  because it mainly supplies the iron loss plus small quantity of primary Cu loss.

$$I_w = I_0 \cos \phi_0$$

(ii) The other component is in quadrature with  $V_1$  and is known as **magnetising** component  $I_\mu$  because its function is to sustain the alternating flux in the core. It is wattless.

$$I_\mu = I_0 \sin \phi_0$$

Obviously,  $I_0$  is the vector sum of  $I_w$  and  $I_\mu$ , hence  $I_0 = \sqrt{I_\mu^2 + I_w^2}$ .

The following points should be noted carefully :

1. The no-load primary current  $I_0$  is very small as compared to the full-load primary current. It is about 1 per cent of the full-load current.
2. Owing to the fact that the permeability of the core varies with the instantaneous value of the exciting current, the wave of the exciting or magnetising current is not truly sinusoidal. As such it should not be represented by a vector because only sinusoidally varying quantities are represented by rotating vectors. But, in practice, it makes no appreciable difference.
3. As  $I_0$  is very small, the no-load primary Cu loss is negligibly small which means **that no-load primary input is practically equal to the iron loss in the transformer.**
4. As it is principally the core-loss which is responsible for shift in the current vector, angle  $\phi_0$  is known as **hysteresis angle of advance.**

**Example 32.9. (a)** A 2,200/200-V transformer draws a no-load primary current of 0.6 A and absorbs 400 watts. Find the magnetising and iron loss currents.

**(b)** A 2,200/250-V transformer takes 0.5 A at a p.f. of 0.3 on open circuit. Find magnetising and working components of no-load primary current.

**Solution. (a)** Iron-loss current

$$= \frac{\text{no-load input in watts}}{\text{primary voltage}} = \frac{400}{2,200} = 0.182 \text{ A}$$

Now 
$$I_0^2 = I_w^2 + I_\mu^2$$

Magnetising component 
$$I_\mu = \sqrt{(0.6^2 - 0.182^2)} = 0.572 \text{ A}$$

The two components are shown in Fig. 29.15.

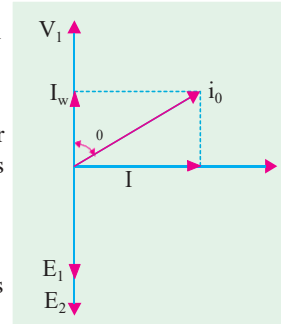

Fig. 32.16

$$(b) \quad I_0 = 0.5 \text{ A}, \cos \phi_0 = 0.3 \therefore I_w = I_0 \cos \phi_0 = 0.5 \times 0.3 = 0.15 \text{ A}$$

$$I_\mu = \sqrt{0.5^2 - 0.15^2} = 0.476 \text{ A}$$

**Example 32.10.** A single-phase transformer has 500 turns on the primary and 40 turns on the secondary winding. The mean length of the magnetic path in the iron core is 150 cm and the joints are equivalent to an air-gap of 0.1 mm. When a p.d. of 3,000 V is applied to the primary, maximum flux density is 1.2 Wb/m<sup>2</sup>. Calculate (a) the cross-sectional area of the core (b) no-load secondary voltage (c) the no-load current drawn by the primary (d) power factor on no-load. Given that AT/cm for a flux density of 1.2 Wb/m<sup>2</sup> in iron to be 5, the corresponding iron loss to be 2 watt/kg at 50 Hz and the density of iron as 7.8 gram/cm<sup>3</sup>.

**Solution. (a)**  $3,000 = 4.44 \times 50 \times 500 \times 1.2 \times A \therefore A = 0.0225 \text{ m}^2 = \mathbf{225 \text{ cm}^2}$

This is the net cross-sectional area. However, the gross area would be about 10% more to allow for the insulation between laminations.

**(b)**  $K = N_2/N_1 = 40/500 = 4/50$   
 $\therefore$  N.L. secondary voltage =  $KE_1 = (4/50) \times 3000 = \mathbf{240 \text{ V}}$

**(c)**  $AT$  per cm = 5  $\therefore AT$  for iron core =  $150 \times 5 = \mathbf{750}$

$$AT \text{ for air-gap} = Hl = \frac{B}{\mu_0} \times l = \frac{1.2}{4\pi \times 10^{-7}} \times 0.0001 = 95.5$$

Total  $AT$  for given  $B_{max} = 750 + 95.5 = 845.5$

Max. value of magnetising current drawn by primary =  $845.5/500 = 1.691 \text{ A}$

Assuming this current to be sinusoidal, its r.m.s. value is  $I_\mu = 1.691/\sqrt{2} = 1.196 \text{ A}$

Volume of iron = length  $\times$  area =  $150 \times 225 = 33,750 \text{ cm}^3$

Density = 7.8 gram/cm<sup>3</sup>  $\therefore$  Mass of iron =  $33,750 \times 7.8/1000 = 263.25 \text{ kg}$

Total iron loss =  $263.25 \times 2 = 526.5 \text{ W}$

Iron loss component of no-load primary current  $I_0$  is  $I_w = 526.5/3000 = 0.176 \text{ A}$

$$I_0 = \sqrt{I_\mu^2 + I_w^2} = \sqrt{1.196^2 + 0.176^2} = \mathbf{0.208 \text{ A}}$$

**(d)** Power factor,  $\cos \phi_0 = I_w/I_0 = 0.176/0.208 = \mathbf{0.1457}$

**Example 32.11.** A single-phase transformer has 1000 turns on the primary and 200 turns on the secondary. The no load current is 3 amp. at a p.f. of 0.2 lagging. Calculate the primary current and power-factor when the secondary current is 280 Amp at a p.f. of 0.80 lagging.

(Nagpur University, November 1997)

**Solution.**  $V_2$  is taken as reference.  $\cos^{-1} 0.80 = 36.87^\circ$

$$I_2 = 280 \angle -36.87^\circ \text{ amp}$$

$$I'_2 = (280/5) \angle -36.87^\circ \text{ amp}$$

$$\phi = \cos^{-1} 0.20 = 78.5^\circ, \sin \phi = 0.98$$

$$I_1 = I_0 + I'_2 = 3(0.20 - j 0.98) + 56(0.80 - j 0.60)$$

$$= 0.6 - j 2.94 + 44.8 - j 33.6$$

$$= 45.4 - j 2.94 + 44.8 - j 33.6$$

$$= 45.4 - j 36.54 = 58.3 \angle 38.86^\circ$$

Thus  $I$  lags behind the supply voltage by an angle of  $38.86^\circ$ .

## Tutorial Problems 32.1

1. The number of turns on the primary and secondary windings of a 1- $\phi$  transformer are 350 and 35 respectively. If the primary is connected to a 2.2 kV, 50-Hz supply, determine the secondary voltage on no-load. **[220 V] (Elect. Engg.-II, Kerala Univ. 1980)**
2. A 3000/200-V, 50-Hz, 1-phase transformer is built on a core having an effective cross-sectional area of 150 cm<sup>2</sup> and has 80 turns in the low-voltage winding. Calculate
  - (a) the value of the maximum flux density in the core
  - (b) the number of turns in the high-voltage winding. **[(a) 0.75 Wb/m<sup>2</sup> (b) 1200]**
3. A 3,300/230-V, 50-Hz, 1-phase transformer is to be worked at a maximum flux density of 1.2 Wb/m<sup>2</sup> in the core. The effective cross-sectional area of the transformer core is 150 cm<sup>2</sup>. Calculate suitable values of primary and secondary turns. **[830; 58]**
4. A 40-kVA, 3,300/240-V, 50 Hz, 1-phase transformer has 660 turns on the primary. Determine
  - (a) the number of turns on the secondary
  - (b) the maximum value of flux in the core
  - (c) the approximate value of primary and secondary full-load currents.
 Internal drops in the windings are to be ignored. **[(a) 48 (b) 22.5 mWb (c) 12.1 A; 166.7 A]**
5. A double-wound, 1-phase transformer is required to step down from 1900 V to 240 V, 50-Hz. It is to have 1.5 V per turn. Calculate the required number of turns on the primary and secondary windings respectively.  
 The peak value of flux density is required to be not more than 1.2 Wb/m<sup>2</sup>. Calculate the required cross-sectional area of the steel core. If the output is 10 kVA, calculate the secondary current. **[1,267; 160; 56.4 cm<sup>2</sup>; 41.75 A]**
6. The no-load voltage ratio in a 1-phase, 50-Hz, core-type transformer is 1,200/440. Find the number of turns in each winding if the maximum flux is to be 0.075 Wb. **[24 and 74 turns]**
7. A 1-phase transformer has 500 primary and 1200 secondary turns. The net cross-sectional area of the core is 75 cm<sup>2</sup>. If the primary winding be connected to a 400-V, 50 Hz supply, calculate.
  - (i) the peak value of flux density in the core and (ii) voltage induced in the secondary winding. **[0.48 Wb/m<sup>2</sup>; 60 V]**
8. A 10-kVA, 1-phase transformer has a turn ratio of 300/23. The primary is connected to a 1500-V, 60 Hz supply. Find the secondary volts on open-circuit and the approximate values of the currents in the two windings on full-load. Find also the maximum value of the flux. **[115 V; 6.67 A; 87 A; 11.75 mWb]**
9. A 100-kVA, 3300/400-V, 50 Hz, 1 phase transformer has 110 turns on the secondary. Calculate the approximate values of the primary and secondary full-load currents, the maximum value of flux in the core and the number of primary turns.  
 How does the core flux vary with load ? **[30.3 A; 250 A; 16.4 mWb; 907]**
10. The no-load current of a transformer is 5.0 A at 0.3 power factor when supplied at 230-V, 50-Hz. The number of turns on the primary winding is 200. Calculate (i) the maximum value of flux in the core (ii) the core loss (iii) the magnetising current. **[5.18 mWb; 345 W; 4.77 A]**
11. The no-load current of a transformer is 15 at a power factor of 0.2 when connected to a 460-V, 50-Hz supply. If the primary winding has 550 turns, calculate
  - (a) the magnetising component of no-load current
  - (b) the iron loss
  - (c) the maximum value of the flux in the core. **[(a) 14.7 A (b) 1,380 W (c) 3.77 mWb]**
12. The no-load current of a transformer is 4.0 A at 0.25 p.f. when supplied at 250-V, 50 Hz. The number of turns on the primary winding is 200. Calculate
  - (i) the r.m.s. value of the flux in the core (assume sinusoidal flux)
  - (ii) the core loss
  - (iii) the magnetising current. **[(i) 3.96 mWb (ii) 250 W (iii) 3.87 A]**

13. The following data apply to a single-phase transformer:  
 output : 100 kVA, secondary voltage; 400 V; Primary turns: 200; secondary turns: 40; Neglecting the losses, calculate: (i) the primary applied voltage (ii) the normal primary and secondary currents (iii) the secondary current, when the load is 25 kW at 0.8 power factor.  
 (Rajiv Gandhi Technical University, Bhopal 2000) [(i) 2000 V, (ii) 50 amp, (iii) 78.125 amp]

**Transformer on Load**

When the secondary is loaded, the secondary current  $I_2$  is set up. The magnitude and phase of  $I_2$  with respect to  $V_2$  is determined by the characteristics of the load. Current  $I_2$  is in phase with  $V_2$  if load is non-inductive, it lags if load is inductive and it leads if load is capacitive.

The secondary current sets up its own m.m.f. ( $=N_2 I_2$ ) and hence its own flux  $\Phi_2$  which is in opposition to the main primary flux  $\Phi$  which is due to  $I_0$ . The secondary ampere-turns  $N_2 I_2$  are known as **demagnetising** amp-turns. The opposing secondary flux  $\Phi_2$  weakens the primary flux  $\Phi$  momentarily, hence primary back e.m.f.  $E_1$  tends to be reduced. For a moment  $V_1$  gains the upper hand over  $E_1$  and hence causes more current to flow in primary.

Let the additional primary current be  $I_2'$ . It is known as **load component of primary current**. This current is antiphase with  $I_2'$ . The additional primary m.m.f.  $N_1 I_2'$  sets up its own flux  $\Phi_2'$  which is in opposition to  $\Phi_2$  (but is in the same direction as  $\Phi$ ) and is equal to it in magnitude. Hence, the two cancel each other out. So, we find that the magnetic effects of secondary current  $I_2$  are immediately neutralized by the additional primary current  $I_2'$  which is brought into existence exactly at the same instant as  $I_2$ . The whole process is illustrated in Fig. 32.17.

Hence, whatever the load conditions, **the net flux passing through the core is approximately the same as at no-load**. An important deduction is that due to the constancy of core flux at all loads, **the core loss is also practically the same under all load conditions**.

$$\text{As } \Phi_2 = \Phi_2' \quad \therefore N_2 I_2 = N_1 I_2' \quad \therefore I_2' = \frac{N_2}{N_1} \times I_2 = KI_2$$

Hence, when transformer is on load, the primary winding has two currents in it; one is  $I_0$  and the other is  $I_2'$  which is anti-phase with  $I_2$  and  $K$  times in magnitude. **The total primary current is the vector sum of  $I_0$  and  $I_2'$** .

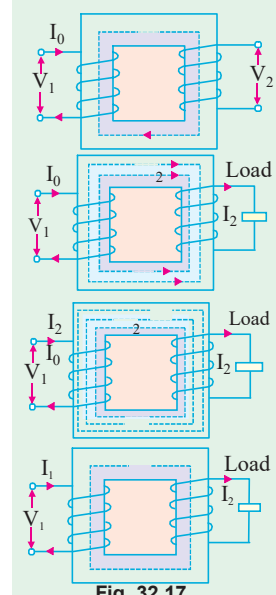

Fig. 32.17

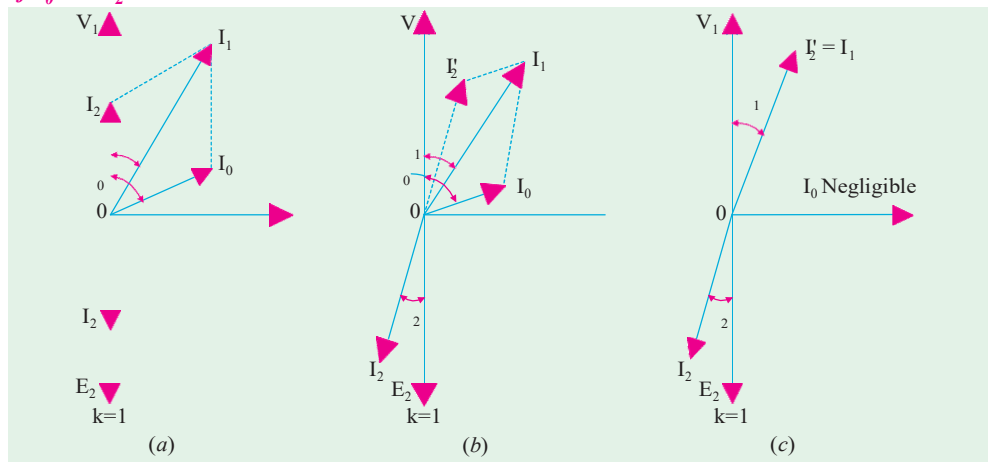

Fig. 32.18

In Fig. 32.18 are shown the vector diagrams for a load transformer when load is non-inductive and when it is inductive (a similar diagram could be drawn for capacitive load). Voltage transformation ratio of unity is assumed so that primary vectors are equal to the secondary vectors. With reference to Fig. 32.18 (a),  $I_2$  is secondary current in phase with  $E_2$  (strictly speaking it should be  $V_2$ ). It causes primary current  $I_2'$  which is anti-phase with it and equal to it in magnitude ( $K = 1$ ). Total primary current  $I_1$  is the vector sum of  $I_0$  and  $I_2'$  and lags behind  $V_1$  by an angle  $\phi_1$ .

In Fig. 32.18 (b) vectors are drawn for an inductive load. Here  $I_2$  lags  $E_2$  (actually  $V_2$ ) by  $\phi_2$ . Current  $I_2'$  is again antiphase with  $I_2$  and equal to it in magnitude. As before,  $I_1$  is the vector sum of  $I_2'$  and  $I_0$  and lags behind  $V_1$  by  $\phi_1$ .

It will be observed that  $\phi_1$  is slightly greater than  $\phi_2$ . But if we neglect  $I_0$  as compared to  $I_2'$  as in Fig. 32.18 (c), then  $\phi_1 = \phi_2$ . Moreover, under this assumption

$$N_1 I_2' = N_2 I_1 = N_1 I_2 \therefore \frac{I_2'}{I_2} = \frac{I_1}{I_2} = N = \frac{N_2}{N_1} K$$

It shows that under full-load conditions, the ratio of primary and secondary currents is constant. This important relationship is made the basis of current transformer—a transformer which is used with a low-range ammeter for measuring currents in circuits where the direct connection of the ammeter is impracticable.

**Example 32.12.** A single-phase transformer with a ratio of 440/110-V takes a no-load current of 5A at 0.2 power factor lagging. If the secondary supplies a current of 120 A at a p.f. of 0.8 lagging, estimate the current taken by the primary. (Elect. Engg. Punjab Univ. 1991)

**Solution.**  $\cos \phi_2 = 0.8, \phi_2 = \cos^{-1}(0.8) = 36^\circ 54'$   
 $\cos \phi_0 = 0.2 \therefore \phi_0 = \cos^{-1}(0.2) = 78^\circ 30'$   
 Now  $\frac{K = V_2/V_1 = 110/440 = 1/4}{I_2' = K I_2 = 120 \times 1/4 = 30 \text{ A}}$   
 $I_0 = 5 \text{ A.}$

Angle between  $I_0$  and  $I_2'$   
 $= 78^\circ 30' - 36^\circ 54' = 41^\circ 36'$

Using parallelogram law of vectors (Fig. 32.19) we get

$$I_1 = \sqrt{5^2 + 30^2 + 2 \times 5 \times 30 \times \cos 41^\circ 36'} = 34.45 \text{ A}$$

The resultant current could also have been found by resolving  $I_2'$  and  $I_0$  into their X and Y-components.

**Example 32.13.** A transformer has a primary winding of 800 turns and a secondary winding of 200 turns. When the load current on the secondary is 80 A at 0.8 power factor lagging, the primary current is 25 A at 0.707 power factor lagging. Determine graphically or otherwise the no-load current of the transformer and its phase with respect to the voltage.

**Solution.** Here  $K = 200/800 = 1/4; I_2' = 80 \times 1/4 = 20 \text{ A}$   
 $\phi_2 = \cos^{-1}(0.8) = 36.9^\circ; \phi_1 = \cos^{-1}(0.707) = 45^\circ$

As seen from Fig. 32.20,  $I_1$  is the vector sum of  $I_0$  and  $I_2'$ . Let  $I_0$  lag behind  $V_1$  by an angle  $\phi_0$ .

$$I_0 \cos \phi_0 + 20 \cos 36.9^\circ = 25 \cos 45^\circ$$

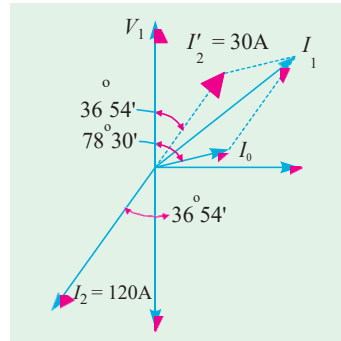

Fig. 32.19

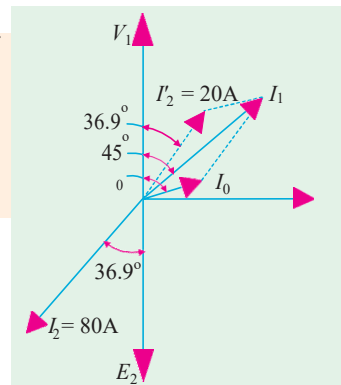

Fig. 32.20



$$\begin{aligned} \therefore I_0 \cos \phi_2 &= 25 \times 0.707 - 20 \times 0.8 \\ &= 1.675 \text{ A} \\ I_0 \sin \phi_0 + 20 \sin 36.9^\circ &= 25 \sin 45^\circ \\ \therefore I_0 \sin \phi_0 &= 25 \times 0.707 - 20 \times 0.6 \\ &= 5.675 \text{ A} \\ \therefore \tan \phi_0 &= 5.675/1.675 = 3.388 \\ \therefore \phi_0 &= 73.3^\circ \\ \text{Now, } I_0 \sin \phi_0 &= 5.675 \\ \therefore I_0 &= 5.675/\sin 73.3^\circ = 5.93 \text{ A} \end{aligned}$$

**Example 32.14.** A single phase transformer takes 10 A on no load at p.f. of 0.2 lagging. The turns ratio is 4 : 1 (step down). If the load on the secondary is 200 A at a p.f. of 0.85 lagging. Find the primary current and power factor.

Neglect the voltage-drop in the winding.

(Nagpur University November 1999)

**Solution.** Secondary load of 200 A, 0.85 lag is reflected as 50 A, 0.85 lag in terms of the primary equivalent current.

$$I_0 = 10 \angle -\phi_0, \text{ where } \phi_0 = \cos^{-1} 0.20 = 78.5^\circ \text{ lagging}$$

$$= 2 - j 9.8 \text{ amp}$$

$$I_2' = 50 \angle -\phi_L \text{ where } \phi_L = \cos^{-1} 0.85 = 31.8^\circ, \text{ lagging}$$

$$I_2' = 42.5 - j 26.35$$

Hence primary current  $I_1$

$$= I_0 + I_2'$$

$$= 2 - j 9.8 + 42.5 - j 26.35$$

$$= 44.5 - j 36.15$$

$$|I_1| = 57.333 \text{ amp, } \phi = 0.776 \text{ Lag.}$$

$$\phi = \cos^{-1} \frac{44.5}{57.333} = 39.10^\circ \text{ lagging}$$

The phasor diagram is shown in Fig. 32.21.

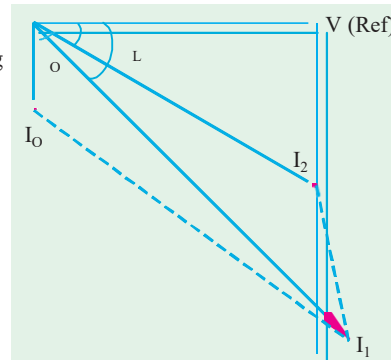

Fig. 32.21

### Tutorial Problems 32.2

- The primary of a certain transformer takes 1 A at a power factor of 0.4 when it is connected across a 200-V, 50-Hz supply and the secondary is on open circuit. The number of turns on the primary is twice that on the secondary. A load taking 50 A at a lagging power factor of 0.8 is now connected across the secondary. What is now the value of primary current? [25.9 A]
- The number of turns on the primary and secondary windings of a single-phase transformer are 350 and 38 respectively. If the primary winding is connected to a 2.2 kV, 50-Hz supply, determine
  - the secondary voltage on no-load,
  - the primary current when the secondary current is 200 A at 0.8 p.f. lagging, if the no-load current is 5 A at 0.2 p.f. lagging,
  - the power factor of the primary current. [239 V; 25-65 A; 0.715 lag]
- A 400/200-V, 1-phase transformer is supplying a load of 25 A at a p.f. of 0.866 lagging. On no-load the current and power factor are 2 A and 0.208 respectively. Calculate the current taken from the supply. [13.9 A lagging V1 by 36.1°]
- A transformer takes 10 A on no-load at a power factor of 0.1. The turn ratio is 4 : 1 (step down). If

a load is supplied by the secondary at 200 A and p.f. of 0.8, find the primary current and power factor (internal voltage drops in transformer are to be ignored). [57.2 A; 0.717 lagging]

5. A 1-phase transformer is supplied at 1,600 V on the h.v. side and has a turn ratio of 8 : 1. The transformer supplies a load of 20 kW at a power factor of 0.8 lag and takes a magnetising current of 2.0 A at a power factor of 0.2. Calculate the magnitude and phase of the current taken from the h.v. supply. [17.15 A ; 0.753 lag] (Elect. Engg. Calcutta Univ. 1980)

6. A 2,200/200-V, transformer takes 1 A at the H.T. side on no-load at a p.f. of 0.385 lagging. Calculate the iron losses.  
If a load of 50 A at a power of 0.8 lagging is taken from the secondary of the transformer, calculate the actual primary current and its power factor. [847 W; 5.44 A; 0.74 lag]

7. A 400/200-V, 1-phase transformer is supplying a load of 50 A at a power factor of 0.866 lagging. The no-load current is 2 A at 0.208 p.f. lagging. Calculate the primary current and primary power factor. [26.4 A; 0.838 lag] (Elect. Machines-I, Indore Univ. 1980)

### Transformer with Winding Resistance but No Magnetic Leakage

An ideal transformer was supposed to possess no resistance, but in an actual transformer, there is always present some resistance of the primary and secondary windings. Due to this resistance, there is some voltage drop in the two windings. The result is that :

(i) The secondary terminal voltage  $V_2$  is vectorially less than the secondary induced e.m.f.  $E_2$  by an amount  $I_2 R_2$  where  $R_2$  is the resistance of the secondary winding. Hence,  $V_2$  is equal to the vector difference of  $E_2$  and resistive voltage drop  $I_2 R_2$ .

$$\therefore V_2 = E_2 - I_2 R_2 \quad \dots \text{vector difference}$$

(ii) Similarly, primary induced e.m.f.  $E_1$  is equal to the vector difference of  $V_1$  and  $I_1 R_1$  where  $R_1$  is the resistance of the primary winding.

$$E_1 = V_1 - I_1 R_1 \quad \dots \text{vector difference}$$

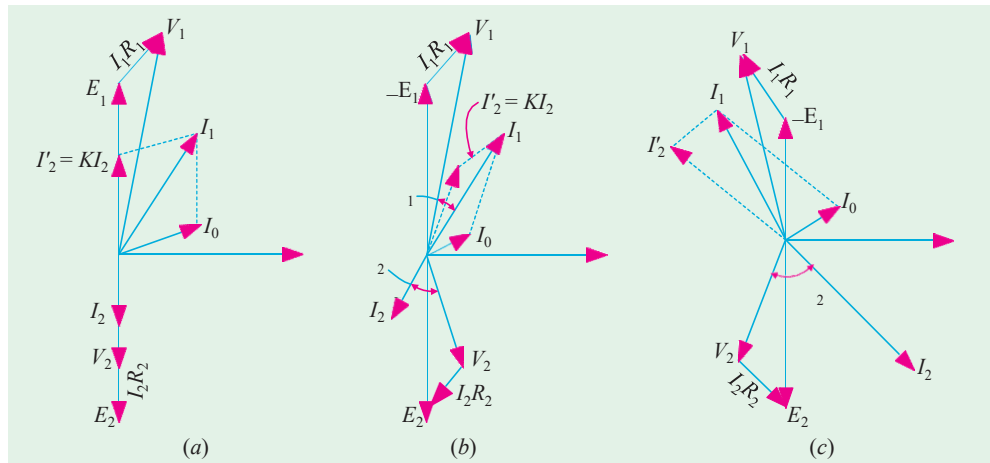

Fig. 32.22

The vector diagrams for non-inductive, inductive and capacitive loads are shown in Fig. 32.22 (a), (b) and (c) respectively.

### Equivalent Resistance

In Fig. 32.23 a transformer is shown whose primary and secondary windings have resistances of  $R_1$  and  $R_2$  respectively. The resistances have been shown external to the windings.

It would now be shown that the resistances of the two windings can be transferred to any one of the two windings. The advantage of concentrating both the resistances in one winding is that it makes calculations very simple and easy because one has then to work in one winding only. It will be proved that a resistance of  $R_2$  in secondary is equivalent to  $R_2/K^2$  in primary. The value  $R_2/K^2$  will be denoted by  $R'_2$  the equivalent

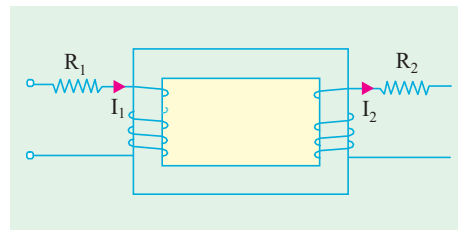

Fig. 32.23

**secondary resistance as referred to primary.**

The copper loss in secondary is  $I_2^2 R_2$ . This loss is supplied by primary which takes a current of  $I_1$ . Hence if  $R'_2$  is the **equivalent resistance in primary which would have caused the same loss** as  $R_2$  in secondary, then

$$I_1^2 R'_2 = I_2^2 R_2 \text{ or } R'_2 = (I_2/I_1)^2 R_2$$

Now, if **we neglect no-load current**  $I_0$ , then  $I_2/I_1 = 1/K$ . Hence,  $R'_2 = R_2/K^2$

Similarly, equivalent primary resistance as referred to secondary is  $R_1 = K^2 R'_1$

In Fig. 32.24, secondary resistance has been transferred to primary side leaving secondary circuit resistanceless. The resistance  $R_1 + R'_2 = R_1 + R_2/K^2$  is known as the **equivalent or effective resistance of the transformer as referred to primary** and may be designated as  $R_{01}$ .

$$R_{01} = R_1 + R'_2 = R_1 + R_2/K^2$$

Similarly, the **equivalent resistance of the transformer as referred to secondary is**

$$R_{02} = R_2 + R'_1 = R_2 + K^2 R_1$$

This fact is shown in Fig. 32.25 where all the resistances of the transformer has been concentrated in the secondary winding.

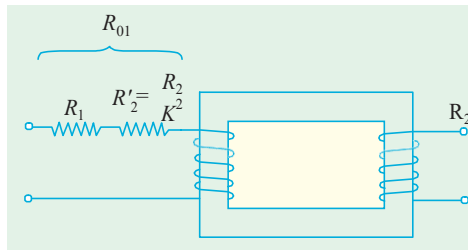

Fig. 32.24

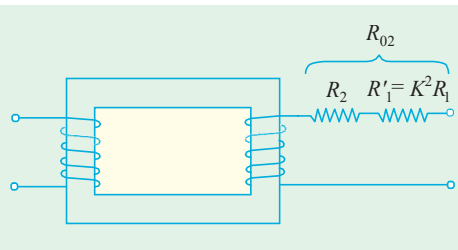

Fig. 32.25

It is to be noted that

1. a resistance of  $R_1$  in primary is equivalent to  $K^2 R_1$  in secondary. Hence, it is called **equivalent resistance as referred to secondary** i.e.  $R'_1$ .
2. a resistance of  $R_2$  in secondary is equivalent to  $R_2/K^2$  in primary. Hence, it is called the **equivalent secondary resistance as referred to primary** i.e.  $R'_2$ .
3. Total or effective resistance of the transformer as referred to primary is

$$R_{01} = \text{primary resistance} + \text{equivalent secondary resistance as referred to primary}$$

$$= R_1 + R'_2 = R_1 + R_2/K^2$$

4. Similarly, total transformer resistance as referred to secondary is,

$$R_{02} = \text{secondary resistance} + \text{equivalent primary resistance as referred to secondary}$$

$$= R_2 + R'_1 = R_2 + K^2 R_1$$

\* Actually  $I_2 \neq 2/I_2 = I/K$  and not  $I_2 \neq 2/I_1$ . However, if  $I_0$  is neglected, then  $I_2 = I_1$ .

**Note :** It is important to remember that

- (a) when shifting any primary resistance to the secondary, **multiply** it by  $K^2$  i.e. (transformation ratio)<sup>2</sup>.
- (b) when shifting secondary resistance to the primary, **divide** it by  $K^2$ .
- (c) however, when shifting any voltage from one winding to another only  $K$  is used.

### Magnetic Leakage

In the preceding discussion, it has been assumed that all the flux linked with primary winding also links the secondary winding. But, in practice, it is impossible to realize this condition. It is found, however, that all the flux linked with primary does not link the secondary but part of it i.e.  $\Phi_{L_1}$  completes its magnetic circuit by passing through air rather than around the core, as shown in Fig. 32.26. This leakage flux is produced when the m.m.f. due to primary ampere-turns existing between points  $a$  and  $b$ , acts along the leakage paths.

Hence, this flux is known as **primary leakage flux** and is proportional to the primary ampere-turns alone because the secondary turns do not link the magnetic circuit of  $\Phi_{L_1}$ . The flux  $\Phi_{L_1}$  is in time phase with  $I_1$ . It induces an e.m.f.  $e_{L_1}$  in primary but not in secondary.

Similarly, secondary ampere-turns (or m.m.f.) acting across points  $c$  and  $d$  set up leakage flux  $\Phi_{L_2}$  which is linked with secondary winding alone (and not with primary turns). This flux  $\Phi_{L_2}$  is in time phase with  $I_2$  and produces a self-induced e.m.f.  $e_{L_2}$  in secondary (but not in primary).

At no load and light loads, the primary and secondary ampere-turns are small, hence leakage fluxes are negligible. But when load is increased, both primary and secondary windings carry huge currents. Hence, large m.m.f.s are set up which, while acting on leakage paths, increase the leakage flux.

As said earlier, the leakage flux linking with each winding, produces a self-induced e.m.f. in that winding. Hence, in effect, it is equivalent to a small choker or inductive coil in series with each winding such that voltage drop in each series coil is equal to that produced by leakage flux. In other words, **a transformer with magnetic leakage is equivalent to an ideal transformer with inductive coils connected in both primary and secondary circuits** as shown in Fig. 32.27 such that the internal e.m.f. in each inductive coil is equal to that due to the corresponding leakage flux in the actual transformer.

$$X_1 = e_{L_1}/I_1 \text{ and } X_2 = e_{L_2}/I_2$$

The terms  $X_1$  and  $X_2$  are known as primary and secondary *leakage reactances* respectively.

Following few points should be kept in mind :

1. The leakage flux links one or the other winding but **not both**, hence it in no way contributes to the transfer of energy from the primary to the secondary winding.
2. The primary voltage  $V_1$  will have to supply reactive drop  $I_1 X_1$  in addition to  $I_1 R_1$ . Similarly  $E_2$  will have to supply  $I_2 R_2$  and  $I_2 X_2$ .
3. In an actual transformer, the primary and secondary windings are not placed on separate legs or limbs as shown in Fig. 32.27 because due to their being widely separated, large primary and secondary leakage fluxes would result. These leakage fluxes are minimised by sectionalizing and interleaving the primary and secondary windings as in Fig. 32.6 or Fig. 32.8.

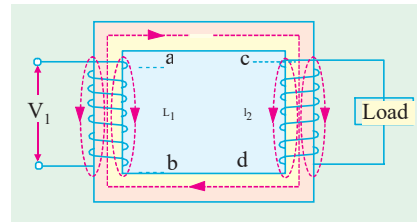

Fig. 32.26

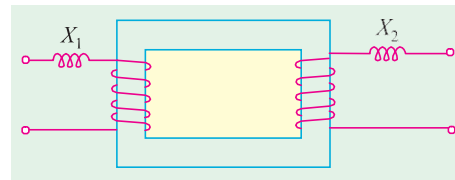

Fig. 32.27

### Transformer with Resistance and Leakage Reactance

In Fig. 32.28 the primary and secondary windings of a transformer with reactances taken out of the windings are shown. The primary impedance is given by

$$Z_1 = \sqrt{(R_1^2 + X_1^2)}$$

Similarly, secondary impedance is given by

$$Z_2 = \sqrt{(R_2^2 + X_2^2)}$$

The resistance and leakage reactance of each winding is responsible for some voltage drop in each winding. In primary, the leakage reactance drop is  $I_1 X_1$  (usually 1 or 2% of  $V_1$ ). Hence

$$V_1 = E_1 + I_1 (R_1 + jX_1) = E_1 + I_1 Z_1$$

Similarly, there are  $I_2 R_2$  and  $I_2 X_2$  drops in secondary which combine with  $V_2$  to give  $E_2$ .

$$E_2 = V_2 + I_2 (R_2 + jX_2) = V_2 + I_2 Z_2$$

The vector diagram for such a transformer for different kinds of loads is shown in Fig. 32.29. In these diagrams, vectors for resistive drops are drawn parallel to current vectors whereas reactive drops are perpendicular to the current vectors. The angle  $\phi_1$  between  $V_1$  and  $I_1$  gives the power factor angle of the transformer.

It may be noted that leakage reactances can also be transferred from one winding to the other in the same way as resistance.

$$\therefore X_2 \Leftarrow X_2 / K^2 \quad \text{and} \quad X_1 \Leftarrow K^2 X_1$$

and  $X_{01} = X_1 + X_2 \Leftarrow X_1 + X_2 / K^2$  and  $X_{02} = X_2 + X_1 \Leftarrow X_2 + K^2 X_1$

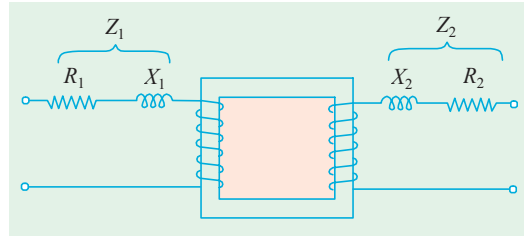

Fig. 32.28

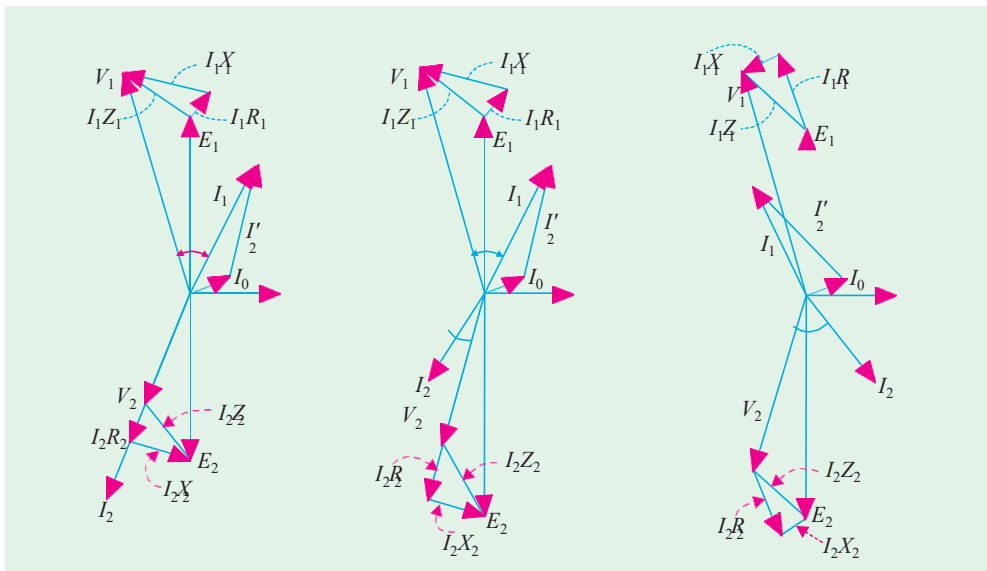

Fig. 32.29

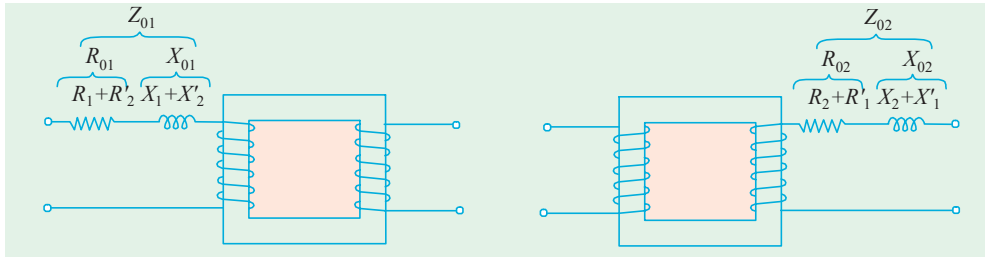

Fig. 32.30 (a)

Fig. 32.30 (b)

It is obvious that total impedance of the transformer as referred to primary is given by

$$Z_{01} = \sqrt{(R_{01}^2 + X_{01}^2)} \quad \dots \text{Fig. 32.30 (a)}$$

and

$$Z_{02} = \sqrt{(R_{02}^2 + X_{02}^2)} \quad \dots \text{Fig. 32.30 (b)}$$

**Example 32.15.** A 30 kVA, 2400/120-V, 50-Hz transformer has a high voltage winding resistance of 0.1 Ω and a leakage reactance of 0.22Ω. The low voltage winding resistance is 0.035 Ω and the leakage reactance is 0.012 Ω. Find the equivalent winding resistance, reactance and impedance referred to the (i) high voltage side and (ii) the low-voltage side.

(Electrical Machines-I, Bangalore Univ. 1987)

**Solution.**

$$K = 120/2400 = 1/20; R_1 = 0.1 \Omega, X_1 = 0.22 \Omega$$

$$R_2 = 0.035 \Omega \quad \text{and} \quad X_2 = 0.012 \Omega$$

(i) Here, high-voltage side is, obviously, the primary side. Hence, values as referred to primary side are

$$R_{01} = R_1 + R_2 \times K^2 = R_1 + R_2/K^2 = 0.1 + 0.035/(1/20)^2 = 14.1 \Omega$$

$$X_{01} = X_1 + X_2 \times K^2 = X_1 + X_2/K^2 = 0.22 + 0.12/(1/20)^2 = 5.02 \Omega$$

$$Z_{01} = \sqrt{R_{01}^2 + X_{01}^2} = \sqrt{14.1^2 + 5.02^2} = 15 \Omega$$

(ii)

$$R_{02} = R_2 + R_1 \times K^2 = R_2 + K^2 R_1 = 0.035 + (1/20)^2 \times 0.1 = 0.03525 \Omega$$

$$X_{02} = X_2 + X_1 \times K^2 = X_2 + K^2 X_1 = 0.012 + (1/20)^2 \times 0.22 = 0.01255 \Omega$$

$$Z_{02} = \sqrt{R_{02}^2 + X_{02}^2} = \sqrt{0.0325^2 + 0.01255^2} = 0.0374 \Omega$$

$$\text{(or } Z_{02} = K^2 Z_{01} = (1/20)^2 \times 15 = 0.0375 \Omega \text{)}$$

**Example 32.16.** A 50-kVA, 4,400/220-V transformer has  $R_1 = 3.45 \Omega$ ,  $R_2 = 0.009 \Omega$ . The values of reactances are  $X_1 = 5.2 \Omega$  and  $X_2 = 0.015 \Omega$ . Calculate for the transformer (i) equivalent resistance as referred to primary (ii) equivalent resistance as referred to secondary (iii) equivalent reactance as referred to both primary and secondary (iv) equivalent impedance as referred to both primary and secondary (v) total Cu loss, first using individual resistances of the two windings and secondly, using equivalent resistances as referred to each side.

(Elect. Engg.-I, Nagpur Univ. 1993)

**Solution.** Full-load

$$I_1 = 50,000/4,400 = 11.36 \text{ A (assuming 100% efficiency)}$$

Full-load

$$I_2 = 50,000/220 = 227 \text{ A}; K = 220/4,400 = 1/20$$

(i)

$$R_{01} = R_1 + \frac{R_2}{K^2} = 3.45 + \frac{0.009}{(1/20)^2} = 3.45 + 3.6 = 7.05 \Omega$$

(ii)

$$R_{02} = R_2 + K^2 R_1 = 0.009 + (1/20)^2 \times 3.45 = 0.009 + 0.0086 = 0.0176 \Omega$$

Also,

$$R_{02} = K^2 R_{01} = (1/20)^2 \times 7.05 = 0.0176 \Omega \text{ (check)}$$

(iii)  $X_{01} = X_1 + X_2 \frac{X_1}{X_2} + X_2 / K^2 = 5.2 + 0.015 / (1/20)^2 = 11.2 \Omega$   
 $X_{02} = X_2 + X_1 \frac{X_2}{X_1} + K^2 X_1 = 0.015 + 5.2 / 20^2 = 0.028 \Omega$   
 Also  $X_{02} = K^2 X_{01} = 11.2 / 400 = 0.028 \Omega$  (check)

(iv)  $Z_{01} = \sqrt{(R_{01}^2 + X_{01}^2)} = \sqrt{(7.05^2 + 11.2)^2} = 13.23 \Omega$   
 $Z_{02} = \sqrt{(R_{02}^2 + X_{02}^2)} = \sqrt{(0.0176^2 + 0.028)^2} = 0.03311 \Omega$   
 Also  $Z_{02} = K^2 Z_{01} = 13.23 / 400 = 0.0331 \Omega$  (check)

(v) Cu loss =  $I_1^2 R_1 + I_2^2 R_2 = 11.36^2 \times 3.45 + 227^2 \times 0.009 = 910 \text{ W}$   
 Also Cu loss =  $I_1^2 R_{01} = 11.36^2 \times 7.05 = 910 \text{ W}$   
 =  $I_2^2 R_{02} = 227^2 \times 0.0176 = 910 \text{ W}$

**Example 32.17.** A transformer with a 10 : 1 ratio and rated at 50-kVA, 2400/240-V, 50-Hz is used to step down the voltage of a distribution system. The low tension voltage is to be kept constant at 240 V.

- (a) What load impedance connected to low-tension side will be loading the transformer fully at power factor (lag) ?  
 (b) What is the value of this impedance referred to high tension side ?  
 (c) What is the value of the current referred to the high tension side ?

(Elect. Engineering-I, Bombay Univ. 1987)

**Solution. (a)** F. L.  $I_2 = 50,000 / 240 = 625 / 3 \text{ A}$ ;  $Z_2 = \frac{240}{(625 / 3)} = 1.142 \Omega$

(b)  $K = 240 / 2400 = 1 / 10$

The secondary impedance referred to primary side is  
 $Z'_2 = Z_2 / K^2 = 1.142 / (1/10)^2 = 114.2 \Omega$

(c) Secondary current referred to primary side is  $I_2' = KI_2 = (1/10) \times 625 / 3 = 20.83 \text{ A}$

**Example 32.18.** The full-load copper loss on the h.v. side of a 100-kVA, 11000/317-V, 1-phase transformer is 0.62 kW and on the L.V. side is 0.48 kW.

- (i) Calculate  $R_1$ ,  $R_2$  and  $R_3$  in ohms (ii) the total reactance is 4 per cent, find  $X_1$ ,  $X_2$  and  $X_3$  in ohms if the reactance is divided in the same proportion as resistance.

(Elect. Machines A.M.I.E., Sec. B, 1991)

**Solution. (i)** F.L.  $I_1 = 100 \times 10^3 / 11000 = 9.1 \text{ A}$ . F.L.  $I_2 = 100 \times 10^3 / 317 = 315.5 \text{ A}$

Now,  $I_1^2 R_1 = 0.62 \text{ kW}$  or  $R_1 = 620 / 9.1^2 = 7.5 \Omega$

$I_2^2 R_2 = 0.48 \text{ kW}$ ,  $R_2 = 480 / 315.5^2 = 0.00482 \Omega$

$R^2 = R / K^2 = 0.00482 \times (11,000 / 317)^2 = 5.8 \Omega$

% reactance =  $\frac{I_1^2 \times X_{01}}{V_1} \times 100$  or  $4 = \frac{9.1^2 \times X_{01}}{11000} \times 100$ ,  $X_{01} = 48.4 \Omega$

$X_1 + X_2' = 48.4 \Omega$ . Given  $R_1 / R_2 = X_1 / X_2'$

or  $(R_1 + R_2) / R_2 = (X_1 + X_2) / X_2$   $(7.5 + 5.8) / 5.8 = 48.4 / X_2'$   $\therefore X_2' = 21.1 \Omega$

$\therefore X_1 = 48.4 - 21.1 = 27.3 \Omega$ ,  $X_2 = 21.1 \times (317 / 11000) = 0.175 \Omega$

**Example 32.19.** The following data refer to a 1-phase transformer :

Turn ratio 19.5 : 1 ;  $R_1 = 25 \Omega$  ;  $X_1 = 100 \Omega$  ;  $R_2 = 0.06 \Omega$  ;  $X_2 = 0.25 \Omega$ . No-load current = 1.25 A leading the flux by  $30^\circ$ .

The secondary delivers 200 A at a terminal voltage of 500 V and p.f. of 0.8 lagging. Determine

by the aid of a vector diagram, the primary applied voltage, the primary p.f. and the efficiency.

(Elect. Machinery-I, Madras Univ. 1989)

**Solution.** The vector diagram is similar to Fig. 30.28 which has been redrawn as Fig. 32.31. Let us take  $V_2$  as the reference vector.

$$\begin{aligned} \therefore \quad V_2 &= 500 \angle 0^\circ = 500 + j0 \\ I_2 &= 200 (0.8 - j 0.6) = 160 - j 120 \\ Z_2 &= (0.06 + j 0.25) \\ E_2 &= V_2 + I_2 Z_2 \\ &= (500 + j 0) + (160 - j 120) (0.06 + j 0.25) \\ &= 500 + (39.6 + j 32.8) = 539.6 + j 32.8 = 541 \angle 3.5^\circ \end{aligned}$$

Obviously,  $\beta = 3.5^\circ$

$$\begin{aligned} E_1 &= E_2/K = 19.5 \quad E_2 = 19.5 (539.6 + j 32.8) \\ &= 10,520 + j 640 \end{aligned}$$

$$\therefore -E_1 = -10,520 - j 640 = 10,540 \angle 183.5^\circ$$

$$\begin{aligned} I_2' &= -I_2 K = (-160 + j 120)/19.5 \\ &= -8.21 + j 6.16 \end{aligned}$$

As seen from Fig. 32.31,  $I_0$  leads  $V_2$  by an angle  $= 3.5^\circ + 90^\circ + 30^\circ = 123.5^\circ$

$$\begin{aligned} \therefore \quad I_0 &= 1.25 \angle 123.5^\circ \\ &= 1.25 (\cos 123.5^\circ + j \sin 123.5^\circ) \\ &= 1.25 (-\cos 56.5^\circ + j \sin 56.5^\circ) \\ &= -0.69 + j 1.04 \end{aligned}$$

$$\begin{aligned} I_1 &= I_2' + I_0 = (-8.21 + j 6.16) + (-0.69 + j 1.04) \\ &= -8.9 + j 7.2 = 11.45 \angle 141^\circ \end{aligned}$$

$$\begin{aligned} V_2 &= -E_1 + I_1 Z_1 \\ &= -10,520 - j 640 + (-8.9 + j 7.5) (25 + j 100) \\ &= -10,520 - j 640 - 942 - j 710 \\ &= -11,462 - j 1350 \\ &= 11,540 \angle 186.7^\circ \end{aligned}$$

Phase angle between  $V_1$  and  $I_1$  is  $= 186.7^\circ - 141^\circ = 45.7^\circ$

$$\therefore \quad \text{primary p.f.} = \cos 45.7^\circ = \mathbf{0.698 \text{ (lag)}}$$

$$\begin{aligned} \text{No-load primary input power} &= V_1 I_0 \sin \phi_0 \\ &= 11,540 \times 1.25 \times \cos 60^\circ = 7,210 \text{ W} \end{aligned}$$

$$R_{02} = R_2 + K^2 R_1 = 0.06 + 25/19.5^2 = 0.1257 \Omega$$

$$\text{Total Cu loss as referred to secondary} = I_2^2 R_{02} = 200^2 \times 0.1257 = 5,030 \text{ W}$$

$$\text{Output} = V_2 I_2 \cos \phi_2 = 500 \times 200 \times 0.8 = 80,000 \text{ W}$$

$$\text{Total losses} = 5030 + 7210 = 12,240 \text{ W}$$

$$\text{Input} = 80,000 + 12,240 = 92,240 \text{ W}$$

$$\eta = 80,000/92,240 = 0.8674 \text{ or } \mathbf{86.74\%}$$

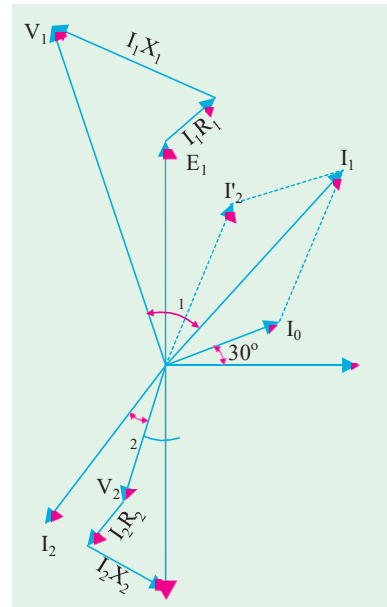

Fig. 32.31

**Example 32.20.** A 100 kVA, 1100/220 V, 50 Hz, single-phase transformer has a leakage impedance of  $(0.1 + j0.4)$  ohm for the H.V. winding and  $(0.006 + j0.015)$  ohm for the L.V. winding. Find the equivalent winding resistance, reactance and impedance referred to the H.V. and L.V. sides.

(Bharathiar Univ. Nov. 1997)



**Solution.** Turns ratio =  $(N_1/N_2) = (V_1/V_2) = 1100/220 = 5$

**(i) Referred to H.V. side :**

Resistance =  $r_1 + r_2 = 0.1 + (25 \times 0.006) = 0.25 \text{ ohm}$   
 Reactance =  $x_1 + x_2 = 0.4 + (25 \times 0.015) = 0.775 \text{ ohm}$   
 Impedance =  $(0.25^2 + 0.775^2)^{0.5} = 0.8143 \text{ ohm}$

**(ii) Referred to L.V. side :**

Resistance =  $0.25/25 = 0.01$   
 (or resistance =  $0.006 + (0.1/25) = 0.01 \text{ ohm}$ )  
 Reactance =  $0.775/25 = 0.031 \text{ ohm}$   
 Impedance =  $0.8143/25 = 0.0326 \text{ ohm}$

**Simplified Diagram**

The vector diagram of Fig. 32.29 may be considerably simplified if the no-load current  $I_0$  is neglected. Since  $I_0$  is 1 to 3 per cent of full-load primary current  $I_1$ , it may be neglected without serious error. Fig. 32.32 shows the diagram of Fig. 32.29 with  $I_0$  omitted altogether.

In Fig. 32.32,  $V_2, V_1, \phi_2$  are known, hence  $E_2$  can be found by adding vectorially  $I_2 R_2$  and  $I_2 X_2$  to  $V_2$ . Similarly,  $V_1$  is given by the vector addition of  $I_1 R_1$  and  $I_1 X_1$  to  $E_1$ . All the voltages on the primary side can be transferred to the secondary side as shown in figure, where the upper part of the diagram has been rotated through  $180^\circ$ . However, it should be noted that each voltage or voltage drop should be multiplied by transformation ratio  $K$ .

The lower side of the diagram has been shown separately in Fig. 32.34 laid horizontally where vector for  $V_2$  has been taken along X-axis.

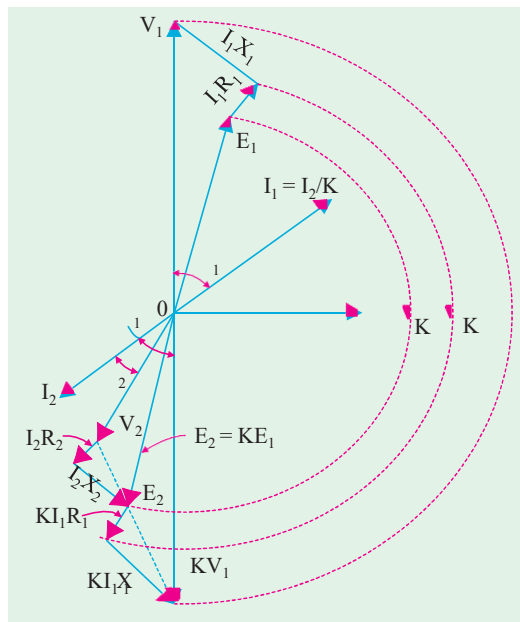

Fig. 32.32

It is a simple matter to find transformer regulation as shown in Fig. 32.34 or Fig. 32.35.

It may be noted that  $V_2 = KV_1 - I_2(R_{02} + jX_{02}) = KV_1 - I_2Z_{02}$ .

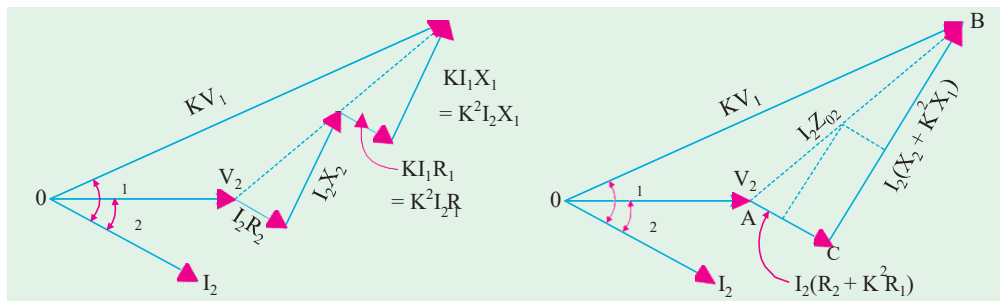

Fig. 32.33

Fig. 32.34

\* Also,  $V_1 = (V_2 + I_2Z_{02}) \# 3/K$

**Total Approximate Voltage Drop in a Transformer**

When the transformer is on *no-load*, then  $V_1$  is approximately equal to  $E_1$ . Hence  $E_2 = KE_1 = KV_1$ . Also,  $E_2 = {}_0V_2$  where  ${}_0V_2$  is secondary terminal voltage on *no-load*, hence no-load secondary terminal voltage is  $KV_1$ . The secondary voltage on load is  $V_2$ . The difference between the two is  $I_2 Z_{02}$  as shown in Fig. 32.35. The approximate voltage drop of the transformer *as referred to secondary* is found thus :

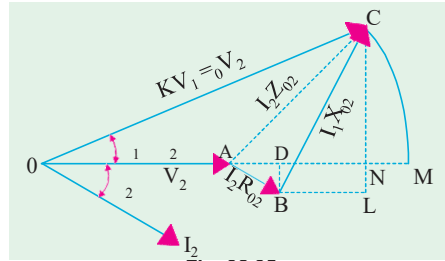

Fig. 32.35

With  $O$  as the centre and radius  $OC$  draw an arc cutting  $OA$  produced at  $M$ . The total voltage drop  $I_2 Z_{02} = AC = AM$  which is approximately equal to  $AN$ . From  $B$  draw  $BD$  perpendicular on  $OA$  produced. Draw  $CN$  perpendicular to  $OM$  and draw  $BL$  parallel to  $OM$ .

Approximate voltage drop  
 $= AN = AD + DN$   
 $= I_2 R_{02} \cos \phi + I_2 X_{02} \sin \phi$

where  $\phi_1 = \phi_2 = \phi$  (approx).

This is the value of approximate voltage drop for a *lagging* power factor.

The different figures for unity and leading power factors are shown in Fig. 32.36 (a) and (b) respectively.

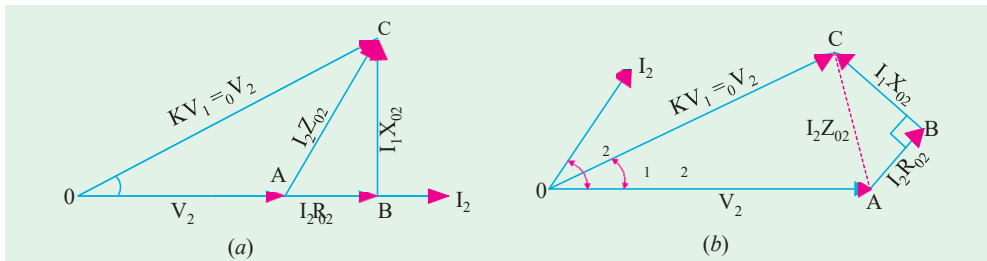

Fig. 32.36

The approximate voltage drop for *leading* power factor becomes

$$(I_2 R_{02} \cos \phi \pm I_2 X_{02} \sin \phi)$$

In general, approximate voltage drop is  $(I_2 R_{02} \cos \phi \pm I_2 X_{02} \sin \phi)$

It may be noted that approximate voltage drop as referred to primary is

$$(I_1 R_{01} \cos \phi \pm I_1 X_{01} \sin \phi)$$

$$\begin{aligned} \text{\% voltage drop in secondary is} &= \frac{I_2 R_{02} \cos \phi \pm I_2 X_{02} \sin \phi}{{}_0V_2} \times 100 \\ &= \frac{100 \times I_2 R_{02} \cos \phi}{{}_0V_2} \pm \frac{100 I_2 X_{02} \sin \phi}{{}_0V_2} \end{aligned}$$

where

$$v_r = \frac{100 I_2 R_{02} \cos \phi}{{}_0V_2} = \text{percentage resistive drop} = \frac{100 I_1 R_{01}}{V_1}$$

$$v_x = \frac{100 I_2 X_{02} \sin \phi}{{}_0V_2} = \text{percentage reactive drop} = \frac{100 I_1 X_{01}}{V_1}$$

### Exact Voltage Drop

With reference to Fig. 32.35, it is to be noted that exact voltage drop is  $AM$  and not  $AN$ . If we add the quantity  $NM$  to  $AN$ , we will get the exact value of the voltage drop.

Considering the right-angled triangle  $OCN$ , we get

$$NC^2 = OC^2 - ON^2 = (OC + ON)(OC - ON) = (OC + ON)(OM - ON) = 2 OC \times NM$$

$$\therefore NM = NC^2 / 2 \cdot OC \text{ Now, } NC = LC - LN = LC - BD$$

$$\therefore NC = I_2 X_{02} \cos \phi - I_2 R_{02} \sin \phi \quad \therefore NM = \frac{(I_2 X_{02} \cos \phi - I_2 R_{02} \sin \phi)^2}{2_0 V_2^2}$$

$\therefore$  For a **lagging** power factor, exact voltage drop is

$$= AN + NM = (I_2 R_{02} \cos \phi + I_2 X_{02} \sin \phi) + \frac{(I_2 X_{02} \cos \phi - I_2 R_{02} \sin \phi)^2}{2_0 V_2^2}$$

For a **leading** power factor, the expression becomes

$$= (I_2 R_{02} \cos \phi - I_2 X_{02} \sin \phi) + \frac{(I_2 X_{02} \cos \phi + I_2 R_{02} \sin \phi)^2}{2_0 V_2^2}$$

In general, the voltage drop is

$$= (I_2 R_{02} \cos \phi \pm I_2 X_{02} \sin \phi) + \frac{(I_2 X_{02} \cos \phi \pm I_2 R_{02} \sin \phi)^2}{2_0 V_2^2}$$

Percentage drop is

$$= \frac{(I_2 R_{02} \cos \phi \pm I_2 X_{02} \sin \phi) \times 100}{V_2} + \frac{(I_2 X_{02} \cos \phi \pm I_2 R_{02} \sin \phi)^2 \times 100}{2_0 V_2^2}$$

$$= \left( \frac{v_r \cos \phi \pm v_x \sin \phi}{V} \right) + (1/200) \left( \frac{v_r \cos \phi \pm v_x \sin \phi}{V} \right)^2$$

The upper signs are to be used for a **lagging** power factor and the lower ones for a **leading** power factor.

**Example 32.21.** A 230/460-V transformer has a primary resistance of  $0.2 \Omega$  and reactance of  $0.5 \Omega$  and the corresponding values for the secondary are  $0.75 \Omega$  and  $1.8 \Omega$  respectively. Find the secondary terminal voltage when supplying  $10 \text{ A}$  at  $0.8 \text{ p.f. lagging}$ .

(Electric. Machines-II, Bangalore Univ. 1991)

**Solution.**

$$K = 460/230 = 2; R_{02} = R_2 + K^2 R_1 = 0.75 + 2^2 \times 0.2 = 1.55 \Omega$$

$$X_{02} = X_2 + K^2 X_1 = 1.8 + 2^2 \times 0.5 = 3.8 \Omega$$

$$\text{Voltage drop} = I_2 (R_{02} \cos \phi + X_{02} \sin \phi) = 10 (1.55 \times 0.8 + 3.8 \times 0.6) = 35.2 \text{ V}$$

$$\therefore \text{Secondary terminal voltage} = 460 - 35.2 = \mathbf{424.8 \text{ V}}$$

**Example 32.22.** Calculate the regulation of a transformer in which the percentage resistance drops is  $1.0\%$  and percentage reactance drop is  $5.0\%$  when the power factor is (a)  $0.8$  lagging (b) unity and (c)  $0.8$  leading. (Electrical Engineering, Banaras Hindu Univ. 1988)

**Solution.** We will use the approximate expression of Art 30.16.

$$(a) \text{ p.f.} = \cos \phi = 0.8 \text{ lag} \quad \mu = v_r \cos \phi + v_x \sin \phi = 1 \times 0.8 + 5 \times 0.6 = \mathbf{3.8\%}$$

$$(b) \text{ p.f.} = \cos \phi = 1 \quad \mu = 1 \times 1 + 5 \times 0 = \mathbf{1\%}$$

$$(c) \text{ p.f.} = \cos \phi = 0.8 \text{ lead} \quad \mu = 1 \times 0.8 - 5 \times 0.6 = \mathbf{-2.2\%}$$

**Example 32.23.** A transformer has a reactance drop of  $5\%$  and a resistance drop of  $2.5\%$ . Find the lagging power factor at which the voltage regulation is maximum and the value of this regulation. (Elect. Engg. Punjab Univ. 1991)

**Solution.** The percentage voltage regulation ( $\mu$ ) is given by

$$\mu = v_r \cos \phi + v_x \sin \phi$$

where  $v_r$  is the percentage resistive drop and  $v_x$  is the percentage reactive drop.

Differentiating the above equation, we get  $\frac{d\mu}{d\phi} = -v_r \sin \phi + v_x \cos \phi$

For regulation to be maximum,  $\frac{d\mu}{d\phi} = 0 \therefore -v_r \sin \phi + v_x \cos \phi = 0$

or  $\tan \phi = v_x/v_r = 5/2.5 = 2 \therefore \phi = \tan^{-1}(2) = 63.5^\circ$  Now,  $\cos \phi = 0.45$  and  $\sin \phi = 0.892$

Maximum percentage regulation =  $(2.5 \times 0.45) + (5 \times 0.892) = 5.585$

Maximum percentage regulation is **5.585** and occurs at a power factor of **0.45** (lag).

**Example 32.24.** Calculate the percentage voltage drop for a transformer with a percentage resistance of 2.5% and a percentage reactance of 5% of rating 500 kVA when it is delivering 400 kVA at 0.8 p.f. lagging. **(Elect. Machinery-I, Indore Univ. 1987)**

**Solution.** 
$$\% \text{ drop} = \frac{(\%R) I \cos \phi}{I_f} + \frac{(\%X) I \sin \phi}{I_f}$$

where  $I_f$  is the full-load current and  $I$  the actual current.

$$\therefore \% \text{ drop} = \frac{(\%R)kW}{kVA \text{ rating}} + \frac{(\%X) kVAR}{kVA \text{ rating}}$$

In the present case, kW =  $400 \times 0.8 = 320$  and kVAR =  $400 \times 0.6 = 240$

$$\therefore \% \text{ drop} = \frac{2.5 \times 320}{500} + \frac{5 \times 240}{500} = 4\%$$

### Equivalent Circuit

The transformer shown diagrammatically in Fig. 32.37 (a) can be resolved into an equivalent circuit in which the resistance and leakage reactance of the transformer are imagined to be external to the winding whose only function then is to transform the voltage (Fig. 32.37 (b)). The no-load

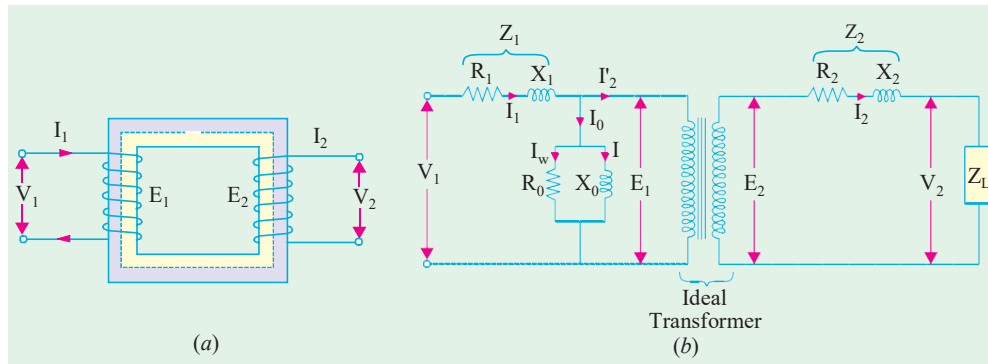

Fig. 32.37

current  $I_0$  is simulated by pure inductance  $X_0$  taking the magnetising component  $I_\mu$  and a non-inductive resistance  $R_0$  taking the working component  $I_w$  connected in parallel across the primary circuit. The value of  $E_1$  is obtained by subtracting vectorially  $I_1 Z_1$  from  $V_1$ . The value of  $X_0 = E_1/I_0$  and of  $R_0 = E_1/I_w$ . It is clear that  $E_1$  and  $E_2$  are related to each other by expression

$$E_2/E_1 = N_2/N_1 = K.$$

To make transformer calculations simpler, it is preferable to transfer voltage, current and impedance

either to the primary or to the secondary. In that case, we would have to work in one winding only which is more convenient.

The primary equivalent of the secondary induced voltage is  $E_2' = E_2/K = E_1$ .

Similarly, primary equivalent of secondary terminal or output voltage is  $V_2' = V_2/K$ .

Primary equivalent of the secondary current is  $I_2' = KI_2$ .

For transferring secondary impedance to primary  $K^2$  is used.

$$R' = R_2/K^2, X_2' = X_2/K^2, Z_L' = Z_L/K^2$$

The same relationship is used for shifting an external load impedance to the primary.

The secondary circuit is shown in Fig. 32.38 (a) and its equivalent primary values are shown in Fig. 32.38 (b).

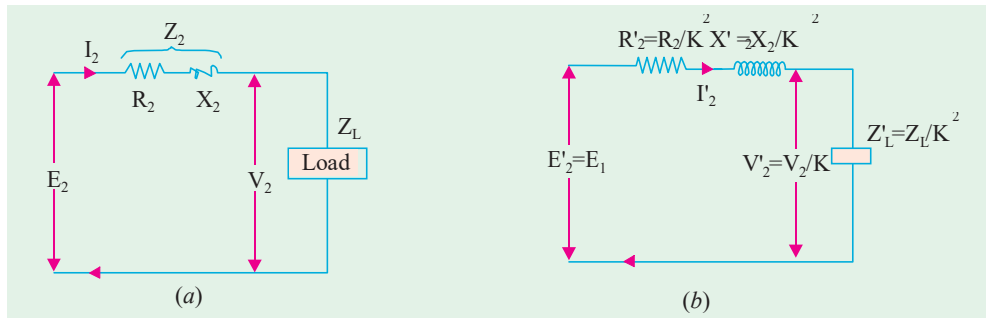

Fig. 32.38

The total equivalent circuit of the transformer is obtained by adding in the primary impedance as shown in Fig. 32.39. This is known as the exact equivalent circuit but it presents a somewhat harder circuit problem to solve. A simplification can be made by transferring the exciting circuit across the terminals as in Fig. 32.40 or in Fig. 32.41 (a). It should be noted that in this case  $X_0 = V_1/I_\mu$ .

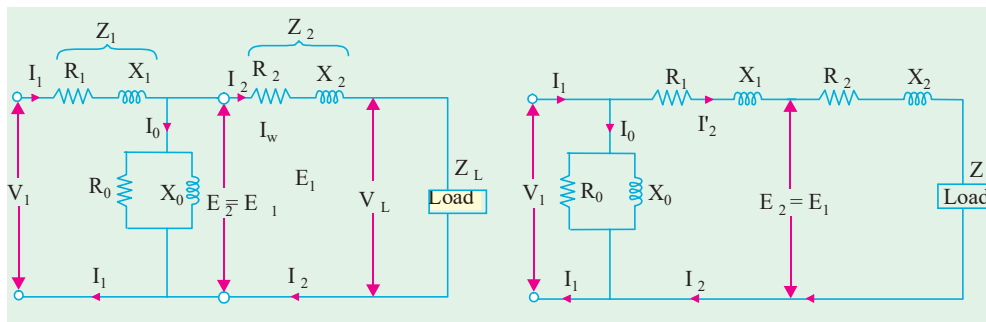

Fig. 32.39

Fig. 32.40

Further simplification may be achieved by omitting  $I_0$  altogether as shown in Fig. 32.41 (b).

From Fig. 32.39 it is found that total impedance between the input terminal is

$$Z = Z_1 + Z_2 \parallel (Z_m + Z_L) = Z_1 + \frac{Z_m (Z_2' + Z_L)}{Z_m + (Z_2' + Z_L)}$$

where

$$Z_2' = R_2 + jX_2 \text{ and } Z_m = \text{impedance of the exciting circuit.}$$

This is so because there are two parallel circuits, one having an impedance of  $Z_m$  and the other having  $Z_2'$  and  $Z_L$  in series with each other.

$$\therefore V_1 = I_1 \left[ Z_1 + \frac{Z_m (Z_2' + Z_L)}{Z_m + (Z_2' + Z_L)} \right]$$

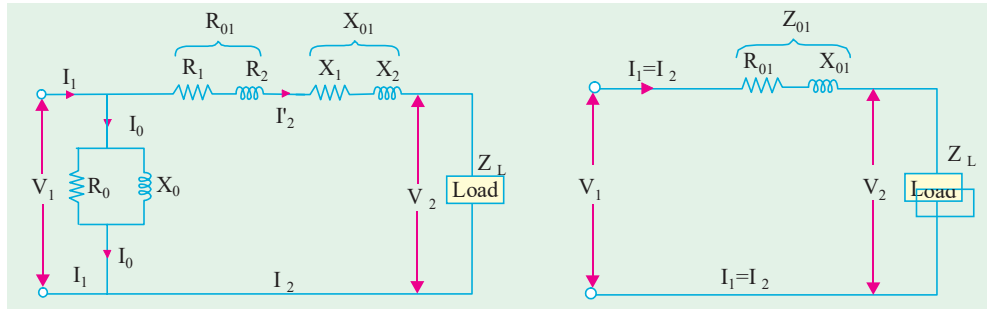

Fig. 32.41 (a)

Fig. 32.41 (b)

**Example 32.25.** The parameters of a 2300/230 V, 50-Hz transformer are given below :

$$R_1 = 0.286 \Omega \quad R_2' = 0.319 \Omega \quad R_0 = 250 \Omega$$

$$X_1 = 0.73 \Omega \quad X_2' = 0.73 \Omega \quad X_0 = 1250 \Omega$$

The secondary load impedance  $Z_L = 0.387 + j 0.29$ . Solve the exact equivalent circuit with normal voltage.

**Solution.**

$$K = 230/2300 = 1/10; \quad Z_L = 0.387 + j 0.29$$

$$Z_L' = Z_L / K^2 = 100 (0.387 + j 0.29) = 38.7 + j 29 = 48.4 \angle 36.8^\circ$$

$$\therefore Z_2' + Z_L' = (38.7 + 0.319) + j(29 + 0.73) = 39.02 + j29.73 = 49.0 \angle 37.3^\circ$$

$$Y_m = (0.004 - j 0.0008); \quad Z_m = 1/Y_m = 240 + j48 = 245 \angle 11.3^\circ$$

$$Z_m + (Z_2' + Z_L') = (240 + j48) + (39 + j29.7) = 279 \angle 15.6^\circ$$

$$\therefore I_1 = \frac{V_1}{Z_m + (Z_2' + Z_L')} = \frac{2300 \angle 0^\circ}{279 \angle 15.6^\circ} = 8.24 \angle -15.6^\circ$$

$$I_1 = \frac{V_1}{Z_1 + \frac{Z_m(Z_2' + Z_L')}{Z_m + (Z_2' + Z_L')}} = \frac{2300 \angle 0^\circ}{0.286 + j0.73 + \frac{245 \angle 11.3^\circ (49.0 \angle 37.3^\circ)}{279 \angle 15.6^\circ}}$$

$$= \frac{2300 \angle 0^\circ}{42 \angle 33.7^\circ} = 54.8 \angle -33.7^\circ$$

$$\text{Now } I_2' = I_1 \times \frac{Z_m}{(Z_2' + Z_L') Z_m} = 54.8 \angle -33.7^\circ \times \frac{245 \angle 11.3^\circ}{290 \angle 15.6^\circ}$$

$$= 54.8 \angle -33.7^\circ \times 0.845 \angle -4.3^\circ = 46.2 \angle -38^\circ$$

$$I = I_1 \times \frac{(Z_2' + Z_L')}{Z_m + (Z_2' + Z_L')} = 54.8 \angle -33.7^\circ \times \frac{49 \angle 37.3^\circ}{290 \angle 15.6^\circ}$$

$$= 54.8 \angle -33.7^\circ \times 0.169 \angle 21.7^\circ = 9.26 \angle -12^\circ$$

Input power factor =  $\cos 33.7^\circ = 0.832$  lagging

Power input =  $V_1 I_1 \cos \phi_1 = 2300 \times 54.8 \times 0.832 = 105 \text{ kW}$

Power output =  $46.2^2 \times 38.7 = 82.7 \text{ kW}$

Primary Cu loss =  $54.8^2 \times 0.286 = 860 \text{ W}$

Secondary Cu loss =  $46.2^2 \times 0.319 = 680 \text{ W}$ ; Core loss =  $9.26^2 \times 240 = 20.6 \text{ kW}$

$$\eta = \frac{(82.7/105) \times 100}{1} = 78.8\%; \quad V_2' = I_2' Z_L' = 46.2 \times 48.4 = 2,240 \text{ V}$$

$$\therefore \text{Regulation} = \frac{2300 - 2240}{2240} \times 100 = 2.7\%$$

**Example 32.26.** A transformer has a primary winding with a voltage-rating of 600 V. Its secondary-voltage rating is 1080 V with an additional tap at 720 V. An 8 kW resistive load is connected across 1080-V output terminals. A purely inductive load of 10kVA is connected across the tapping point and common secondary terminal so as to get 720 V. Calculate the primary current and its power-factor. Correlate it with the existing secondary loads. Neglect losses and magnetizing current. (Nagpur University, Winter 1999)

**Solution.** Loads are connected as shown in Fig. 32.42.

$$I_{r_2} = \frac{8000}{1080} = 7.41 \text{ at unity p.f.}$$

$$I_{L_2} = 10000/720 = 13.89 \text{ at zero lagging p.f.}$$

These are reflected on to the primary sides with appropriate ratios of turns, with corresponding power-factors. If the corresponding transformed currents are represented by the above symbols modified by dashed superscripts,

$$I'_{r_2} = 7.41 \times 1080/600 = 13.34 \text{ A at unity p.f.}$$

$$I'_{L_2} = 13.89 \times 720/600 = 16.67 \text{ A at zero lag. p.f.}$$

Hence,

$$I_{r_2} = [I'^2_{r_2} + I'^2_{L_2}]^{0.5} = 21.35 \text{ A, at } 0.625 \text{ lag p.f.}$$

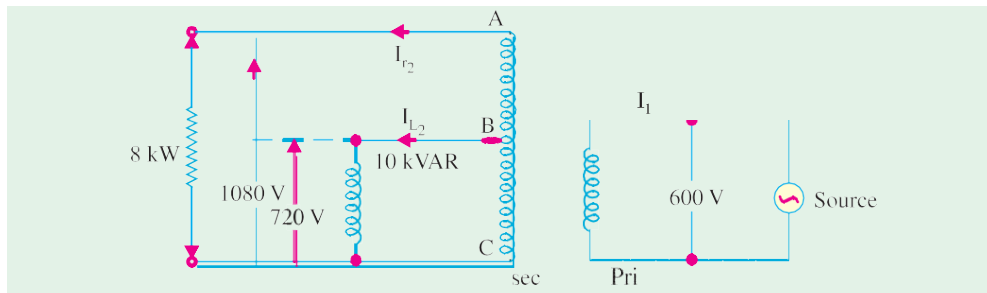

Fig. 32.42

**Correlation:** Since losses and magnetizing current are ignored, the calculations for primary current and its power-factor can also be made with data pertaining to the two Loads (in kW/kVAR), as supplied by the 600 V source.

$S =$  Load to be supplied : 8 kW at unity p.f. and 10 kVAR lagging

Thus,

$$S = P + jQ = 8 - j 10 \text{ kVA}$$

$$S = (8^2 + 10^2)^{0.5} = 12.8 \text{ kVA}$$

$$\text{Power - factor} = \cos \phi = 8/12.8 = 0.625 \text{ lag}$$

$$\text{Primary current} = 12.8 \times 1000/600 = 21.33 \text{ A}$$

### Transformer Tests

As shown in Ex 32.25, the performance of a transformer can be calculated on the basis of its equivalent circuit which contains (Fig. 32.41) four main parameters, the equivalent resistance  $R_{01}$  as referred to primary (or secondary  $R_{02}$ ), the equivalent leakage reactance  $X_{01}$  as referred to primary (or secondary  $X_{02}$ ), the core-loss conductance  $G_0$  (or resistance  $R_0$ ) and the magnetising susceptance  $B_0$  (or reactance  $X_0$ ). These constants or parameters can be easily determined by two tests (i) **open-circuit test** and (ii) **short-circuit test**. These tests are very economical and convenient, because they furnish the required information without actually loading the transformer. In fact, the testing of very large a.c. machinery consists of running two tests similar to the open and short-circuit tests of a transformer.

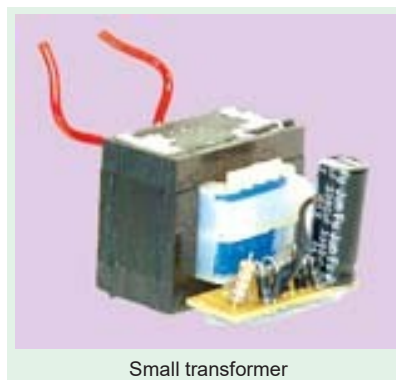

Small transformer

**Open-circuit or No-load Test**

The purpose of this test is to determine no-load loss or core loss and no-load  $I_0$  which is helpful in finding  $X_0$  and  $R_0$ .

One winding of the transformer – whichever is convenient but usually high voltage winding – is left open and the other is connected to its supply of normal voltage and frequency. A wattmeter  $W$ , voltmeter  $V$  and an ammeter  $A$  are connected in the low-voltage winding *i.e.* primary winding in the

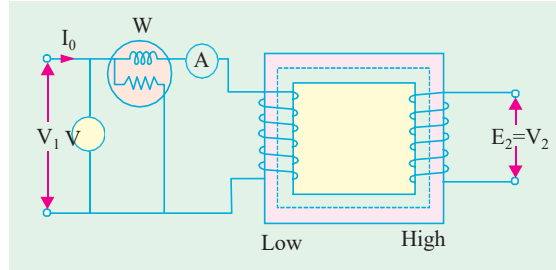

**Fig. 32.43**

present case. With normal voltage applied to the primary, normal flux will be set up in the core, hence normal iron losses will occur which are recorded by the wattmeter. As the primary no-load current  $I_0$  (as measured by ammeter) is small (usually 2 to 10% of rated load current), Cu loss is negligibly small in primary and nil in secondary (it being open). Hence, the wattmeter reading represents practically the core loss under no-load condition (and which is the same for all loads as pointed out in Art. 32.9).

It should be noted that since  $I_0$  is itself very small, the pressure coils of the wattmeter and the voltmeter are connected such that the current in them does not pass through the current coil of the wattmeter.

Sometimes, a high-resistance voltmeter is connected across the secondary. The reading of the voltmeter gives the induced e.m.f. in the secondary winding. This helps to find transformation ratio  $K$ .

The no-load vector diagram is shown in Fig. 32.16. If  $W$  is the wattmeter reading (in Fig. 32.43), then

$$W = V_1 I_0 \cos \phi_0 \quad \therefore \cos \phi_0 = W / V_1 I_0$$

$$\therefore I_\mu = I_0 \sin \phi_0, I_w = I_0 \cos \phi_0 \quad \therefore X_0 = V_1 / I_\mu \text{ and } R_0 = V_1 / I_w$$

Or since the current is practically all-exciting current when a transformer is on no-load (*i.e.*  $I_0 \cong I_\mu$ ) and as the voltage drop in primary leakage impedance is small\*, hence the exciting admittance  $Y_0$  of the transformer is given by  $I_0 = V_1 Y_0$  or  $Y_0 = I_0 / V_1$ .

$$\text{The exciting conductance } G_0 \text{ is given by } W = V_1^2 G_0 \text{ or } G_0 = W / V_1^2$$

$$\text{The exciting susceptance } B_0 = \sqrt{(Y_0^2 - G_0^2)}$$

**Example. 32.27.** In no-load test of single-phase transformer, the following test data were obtained :

Primary voltage : 220 V ; Secondary voltage : 110 V ;

Primary current : 0.5 A ; Power input : 30 W.

Find the following :

- (i) The turns ratio (ii) the magnetising component of no-load current (iii) its working (or loss) component (iv) the iron loss.

Resistance of the primary winding = 0.6 ohm.

Draw the no-load phasor diagram to scale.

**(Elect. Machine A.M.I.E. 1990)**

**Solution.** (i) Turn ratio,  $N_1/N_2 = 220/110 = 2$

(ii)  $W = V_1 I_0 \cos \phi_0$  ;  $\cos \phi_0 = 30/220 \times 0.5 = 0.273$  ;  $\sin \phi_0 = 0.962$

$$I_\mu = I_0 \sin \phi_0 = 0.5 \times 0.962 = 0.48 \text{ A}$$

\* If it is not negligibly small, then  $I_0 = E_1 Y_0$  *i.e.* instead of  $V_1$  we will have to use  $E_1$ .



- (iii)  $I_w = I_0 \cos \phi_0 = 0.5 \times 0.273 = 0.1365 \text{ A}$   
 (iv) Primary Cu loss  $= I^2 R = 10.5^2 \times 0.6 = 0.15 \text{ W}$   
 $\therefore$  Iron loss  $= 30 - 0.15 = 29.85 \text{ W}$

**Example 32.28.** A 5 kVA 200/1000 V, 50 Hz, single-phase transformer gave the following test results :

O.C. Test (L.V. Side) : 2000 V, 1.2 A, 90 W

S.C. Test (H.V. Side) : 50 V, 5A, 110 W

- (i) Calculate the parameters of the equivalent circuit referred to the L.V. side.  
 (ii) Calculate the output secondary voltage when delivering 3 kW at 0.8 p.f. lagging, the input primary voltage being 200 V. Find the percentage regulation also.

(Nagpur University, November 1998)

**Solution.** (i) Shunt branch parameters from O.C. test (L.V. side) :

$$R = V^2/P = 200^2/90 = 444 \text{ ohms}, I = 200/444 = 0.45 \text{ amp}$$

$$I_0 = (1.2^2 - 0.45^2)^{0.5} = 1.11 \text{ amp}, X_m = 200/1.11 = 180.2 \text{ ohms}$$

All these are referred to L.V. side.

(ii) Series-branch Parameters from S.C test (H.V side) :

Since the S.C. test has been conducted from H.V. side, the parameters will refer to H.V. side.

They should be converted to the parameters referred to L.V. side by transforming them suitably.

From S.C. Test readings,  $Z = 50/5 = 10 \text{ ohms}$

$$R = 110/25 = 4.40 \text{ ohms}, X = (10^2 - 4.4^2)^{0.5} = 8.9 \text{ ohms}$$

These are referred to H.V. side.

For referring these to L.V. side, transform these using the ratio of turns, as follows :

$$r_1 = 4.40 \times (200/1000)^2 = 0.176 \text{ ohm}$$

$$x_1 = 8.98 \times (200/1000)^2 = 0.36 \text{ ohm}$$

Equivalent circuit can be drawn with  $R_0$  and  $X_m$  calculated above and  $r_1$  and  $x_1$  as above.

$$\text{L.V. Current at rated load} = 5000/200 = 25 \text{ A}$$

$$\text{L.V. Current at 3 kW at 0.8 lagging p.f.} = (3000/0.80)/200 = 18.75 \text{ A}$$

$$\begin{aligned} \text{Regulation at this load} &= 18.75 (r_1 \cos \phi + x_1 \sin \phi) \\ &= 18.75 (0.176 \times 0.80 + 0.36 \times 0.6) \\ &= + 6.69 \text{ Volts} = + (6.69/200) \times 100\% = + 3.345\% \end{aligned}$$

This is referred to L.V. side, and positive sign means voltage drop.

$$\text{Regulation in volts ref. to H.V. side} = 6.69 \times 1000/200 = 33.45 \text{ V}$$

With 200 V across primary (i.e. L.V. side), the secondary (i.e. H.V. side)

$$\text{terminal voltage} = 1000 - 33.45 = 966.55 \text{ V}$$

**Note:** Since approximate formula for voltage regulation has been used, the procedure is simpler, and faster.

### Separation of Core Losses

The core loss of a transformer depends upon the frequency and the maximum flux density when the volume and the thickness of the core laminations are given. The core loss is made up of two parts (i) hysteresis loss  $W_h = PB^{1.6} f$  as given by Steinmetz's empirical relation and (ii) eddy current loss  $W_e = QB_{\text{max}}^2 f^2$  where  $Q$  is a constant. The total core-loss is given by

$$W = W_h + W_e = PB^{1.6} f^2 + QB_{\text{max}}^2 f^2$$

If we carry out two experiments using two different frequencies but the same maximum flux density, we should be able to find the constants  $P$  and  $Q$  and hence calculate hysteresis and eddy current losses separately.

**Example 32.29.** In a transformer, the core loss is found to be 52 W at 40 Hz and 90 W at 60 Hz measured at same peak flux density. Compute the hysteresis and eddy current losses at 50 Hz.

(Elect. Machines, Nagpur Univ. 1993)

**Solution.** Since the flux density is the same in both cases, we can use the relation

$$\text{Total core loss } W_i = Af + Bf^2 \quad \text{or} \quad W_i/f = A + Bf$$

$$\therefore 52/40 = A + 40B \quad \text{and} \quad 90/60 = A + 60B; \quad \therefore A = 0.9 \quad \text{and} \quad B = 0.01$$

At 50 Hz, the two losses are

$$W_h = A f = 0.9 \times 50 = 45 \text{ W}; \quad W_e = Bf^2 = 0.01 \times 50^2 = 25 \text{ W}$$

**Example 32.30.** In a power loss test on a 10 kg specimen of sheet steel laminations, the maximum flux density and waveform factor are maintained constant and the following results were obtained:

Frequency (Hz)	25	40	50	60	80
Total loss (watt)	18.5	36	50	66	104

Calculate the eddy current loss per kg at a frequency of 50 Hz.

(Elect. Measur. A.M.I.E. Sec B, 1991)

**Solution.** When flux density and wave form factor remain constant, the expression for iron loss can be written as

$$W_i = Af + Bf^2 \quad \text{or} \quad W_i/f = A + Bf$$

The values of  $W_i/f$  for different frequencies are as under :

$f$	25	40	50	60	80
$W_i/f$	0.74	0.9	1.0	1.1	1.3

The graph between  $f$  and  $W_i/f$  has been plotted in Fig. 32.44. As seen from it,  $A = 0.5$  and  $B = 0.01$

$$\therefore \text{Eddy current loss at 50 Hz} = Bf^2 = 0.01 \times 50^2 = 25 \text{ W}$$

$$\therefore \text{Eddy current loss/kg} = 25/10 = 2.5 \text{ W}$$

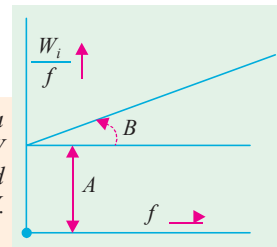

Fig. 32.44

**Example 32.31.** In a test for the determination of the losses of a 440-V, 50-Hz transformer, the total iron losses were found to be 2500 W at normal voltage and frequency. When the applied voltage and frequency were 220 V and 25 Hz, the iron losses were found to be 850 W. Calculate the eddy-current loss at normal voltage and frequency.

(Elect. Inst. and Meas. Punjab Univ. 1991)

**Solution.** The flux density in both cases is the same because in second case voltage as well as frequency are halved. Flux density remaining the same, the eddy current loss is proportional to  $f^2$  and hysteresis loss  $\propto f$ .

$$\text{Hysteresis loss} \propto f = Af \quad \text{and} \quad \text{eddy current loss} \propto f^2 = Bf^2$$

where  $A$  and  $B$  are constants.

$$\text{Total iron loss} \quad W_i = Af + Bf^2 \quad \therefore \quad \frac{W_i}{f} = A + Bf \quad \dots(i)$$

$$\text{Now, when} \quad f = 50 \text{ Hz} : W_i = 2500 \text{ W}$$

$$\text{and when} \quad f = 25 \text{ Hz} ; W_i = 850 \text{ W}$$

Using these values in (i) above, we get, from Fig. 32.44

$$2,500/50 = A + 50B \quad \text{and} \quad 850/25 = A + 25B \quad \therefore B = 16/25 = 0.64$$

Hence, at normal p.d. and frequency

$$\text{eddy current loss} = Bf^2 = 0.64 \times 50^2 = \mathbf{1600 \text{ W}}$$

$$\text{Hysteresis loss} = 2500 - 1600 = 900 \text{ W}$$

**Example 32.32.** When a transformer is connected to a 1000-V, 50-Hz supply the core loss is 1000 W, of which 650 is hysteresis and 350 is eddy current loss. If the applied voltage is raised to 2,000 V and the frequency to 100 Hz, find the new core losses.

**Solution.** Hysteresis loss  $W_h \propto B_{\max}^{1.6} f = PB_{\max}^{1.6} f$

$$\text{Eddy current loss } W_e \propto B_{\max}^2 f^2 = QB_{\max}^2 f^2$$

From the relation  $E = 4.44 f N B_{\max} A$  volt, we get  $B_{\max} \propto E/f$

Putting this value of  $B_{\max}$  in the above equations, we have

$$W_h = P \left( \frac{E}{f} \right)^{1.6} f = PE^{1.6} f^{-0.6} \quad \text{and} \quad W_e = Q \left( \frac{E}{f} \right)^2 f = QE^2$$

In the first case,

$$E = 1000 \text{ V}, f = 50 \text{ Hz}, W_h = 650 \text{ W}, W_e = 350 \text{ W}$$

$$\therefore 650 = P \times 1000^{1.6} \times 50^{-0.6} \quad \therefore P = 650 \times 1000^{-1.6} \times 50^{0.6}$$

Similarly,

$$350 = Q \times 1000^2 \quad \therefore Q = 350 \times 1000^{-2}$$

Hence, constants  $P$  and  $Q$  are known.

Using them in the second case, we get

$$W_h = (650 \times 1000^{-1.6} \times 50^{0.6}) \times 2000^{1.6} \times 100^{-0.6} = 650 \times 2 = 1,300 \text{ W}$$

$$W_e = (350 \times 1000^{-2}) \times 2,000^2 = 350 \times 4 = 1,400 \text{ W}$$

$\therefore$  Core loss under new condition is = 1,300 + 1,400 = **2700 W**

#### Alternative Solution

Here, both voltage and frequency are doubled, leaving the flux density unchanged.

#### With 1000 V at 50 Hz

$$W_h = Af \text{ or } 650 = 50 A; A = 13$$

$$W_e = Bf^2 \text{ or } 350 = B \times 50^2; B = 7/50$$

#### With 2000 V at 100 Hz

$$W_h = Af = 13 \times 100 = 1300 \text{ W and}$$

$$W_e = Bf^2 = (7/50) \times 100^2 = 1400 \text{ W}$$

$\therefore$  New core loss = 1300 + 1400 = **2700 W**

**Example 32.33.** A transformer with normal voltage impressed has a flux density of 1.4 Wb/m<sup>2</sup> and a core loss comprising of 1000 W eddy current loss and 3000 W hysteresis loss. What do these losses become under the following conditions ?

- increasing the applied voltage by 10% at rated frequency.
- reducing the frequency by 10% with normal voltage impressed.
- increasing both impressed voltage and frequency by 10 per cent.

(Electrical Machinery-I, Madras Univ. 1985)

**Solution.** As seen from Ex. 32.32

$$W_h = PE^{1.6} f^{-0.6} \quad \text{and} \quad W_e = QE^2$$

From the given data, we have  $3000 = PE^{1.6} f^{-0.6}$  ...**(i)**

and  $1000 = QE^2$  ...**(ii)**

where  $E$  and  $f$  are the normal values of primary voltage and frequency.

**(a)** Here voltage becomes  $E + 10\% E = 1.1 E$

The new hysteresis loss is  $W_h = P(1.1 E)^{1.6} f^{-0.6}$  ...**(iii)**

Dividing Eq. **(iii)** by **(i)**, we get  $\frac{W_h}{3000} = 1.1^{1.6}$ ;  $W_h = 3000 \times 1.165 = \mathbf{3495 \text{ W}}$

The new eddy-current loss is

$$W_e = Q (1.1 E)^2 \therefore \frac{W_e}{1000} = 1.1^2$$

$$\therefore W_e = 1000 \times 1.21 = \mathbf{1210 \text{ W}}$$

(b) As seen from Eq. (i) above eddy-current loss would not be effected. The new hysteresis loss is

$$W_h = P E^{1.6} (0.9 f)^{-0.6} \dots (iv)$$

From (i) and (iv), we get  $\frac{W_h}{3000} = 0.9^{-0.6}$ ,  $W_h = 3000 \times 1.065 = \mathbf{3,196 \text{ W}}$

(c) In this case, both  $E$  and  $f$  are increased by 10%. The new losses are as under :

$$W_h = P (1.1 E)^{1.6} (1.1 f)^{-0.6}$$

$$\therefore \frac{W_h}{3000} = 1.1^{1.6} \times 1.1^{-0.6} = 1.165 \times 0.944$$

$$\therefore W_h = 3000 \times 1.165 \times 0.944 = \mathbf{3,299 \text{ W}}$$

As  $W_e$  is unaffected by changes in  $f$ , its value is the same as found in (a) above i.e. **1210 W**

**Example 32.34.** A transformer is connected to 2200 V, 40 Hz supply. The core-loss is 800 watts out of which 600 watts are due to hysteresis and the remaining, eddy current losses. Determine the core-loss if the supply voltage and frequency are 3300 V and 60 Hz respectively.

(Bharathiar Univ. Nov. 1997)

**Solution.** For constant flux density (i.e. constant  $V/f$  ratio), which is fulfilled by 2200/40 or 3300/60 figures in two cases,

$$\text{Core-loss} = A f + B f^2$$

First term on the right-hand side represents hysteresis-loss and the second term represents the eddy-current loss.

At 40 Hz,  $800 = 600 + \text{eddy current loss}$ .

Thus,

$$A f = 600, \text{ or } A = 15$$

$$B f^2 = 200, \text{ or } B = 200/1600 = 0.125$$

At 60 Hz,

$$\text{core-loss} = 15 \times 60 + 0.125 \times 60^2$$

$$= 900 + 450$$

$$= 1350 \text{ watts}$$

### 32.22 Short-Circuit or Impedance Test

This is an economical method for determining the following :

(i) Equivalent impedance ( $Z_{01}$  or  $Z_{02}$ ), leakage reactance ( $X_{01}$  or  $X_{02}$ ) and total resistance ( $R_{01}$  or  $R_{02}$ ) of the transformer as referred to the winding in which the measuring instruments are placed.

(ii) Cu loss at full load (and at any desired load). This loss is used in calculating the efficiency of the transformer.

(iii) Knowing  $Z_{01}$  or  $Z_{02}$ , the total voltage drop in the transformer as referred to primary or secondary can be calculated and hence regulation of the transformer determined.

In this test, one winding, usually the low-voltage winding, is solidly short-circuited by a thick conductor (or through an ammeter which may serve the additional purpose of indicating rated load current) as shown in Fig.32.45.

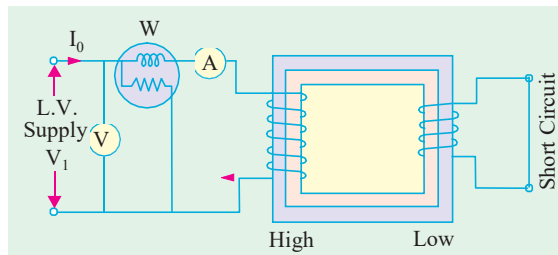

Fig. 32.45

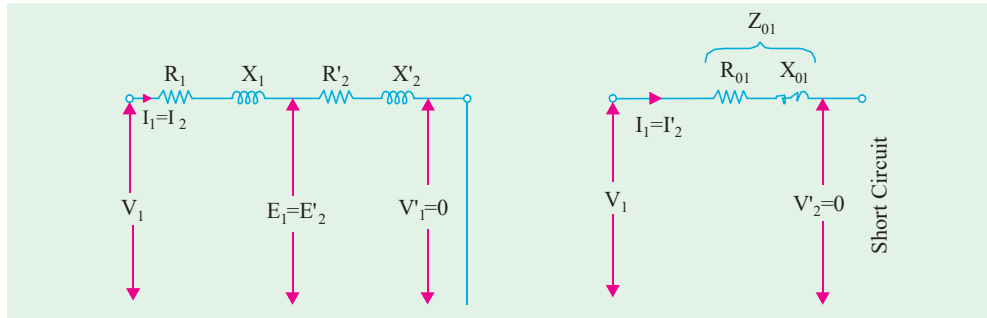

Fig. 32.46

A low voltage (usually 5 to 10% of normal primary voltage) at correct frequency (though for Cu losses it is not essential) is applied to the primary and is cautiously increased till full-load currents are flowing both in primary and secondary (as indicated by the respective ammeters).

Since, in this test, the applied voltage is a small percentage of the normal voltage, the mutual flux  $\Phi$  produced is also a small percentage of its normal value (Art. 32.6). Hence, core losses are very small with the result that the wattmeter reading represent the full-load Cu loss or  $I^2R$  loss for the whole transformer *i.e.* both primary Cu loss and secondary Cu loss. The equivalent circuit of the transformer under short-circuit condition is shown in Fig. 32.46. If  $V_{sc}$  is the voltage required to circulate rated load currents, then  $Z_{01} = V_{sc}/I_1$

Also  $W = I^2 R_{1 \ 01}$

$\therefore R_{01} = W/I_1$

$\therefore X_{01} = \sqrt{\left( Z_{01}^2 - R_{01}^2 \right)}$

In Fig. 32.47 (a) the equivalent circuit vector diagram for the short-circuit test is shown. This diagram is the same as shown in Fig. 32.34 except that all the quantities are referred to the primary side. It is obvious that the entire voltage  $V_{sc}$  is consumed in the impedance drop of the two windings.

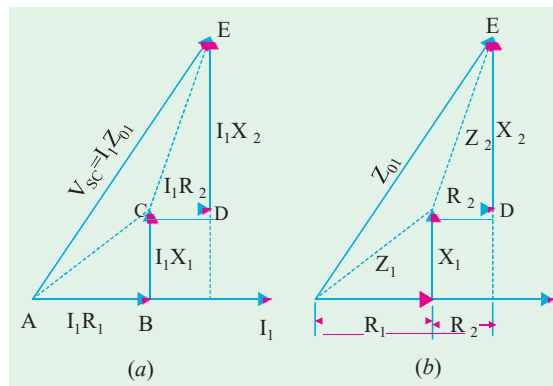

Fig. 32.47

If  $R_1$  can be measured, then knowing  $R_{01}$ , we can find  $R_2 = R_{01} - R_1$ . The impedance triangle can then be divided into the appropriate equivalent triangles for primary and secondary as shown in Fig. 32.47 (b).

### Why Transformer Rating in kVA ?

As seen, Cu loss of a transformer depends on current and iron loss on voltage. Hence, total transformer loss depends on volt-ampere (VA) and not on phase angle between voltage and current *i.e.* it is independent of load power factor. That is why rating of transformers is in kVA and not in kW.

**Example 32.35.** The primary and secondary windings of a 30 kVA 76000/230, V, 1-phase transformer have resistance of 10 ohm and 0.016 ohm respectively. The reactance of the transformer referred to the primary is 34 ohm. Calculate the primary voltage required to circulate full-load current when the secondary is short-circuited. What is the power factor on short circuit ?

(Elect. Machines AMIE Sec. B 1991)

**Solution.**

$$K = 230/6000 = 23/600, X_{01} = 34 \ \Omega,$$

$$R_{01} = R_1 + R_2/K^2 = 10 + 0.016 (600/23)^2 = 20.9 \ \Omega$$

$$Z_{01} = \sqrt{R_{01}^2 + X_{01}^2} = \sqrt{20.9^2 + 34^2} = 40 \Omega$$

$$\text{F.L., } I_1 = 30,000/6000 = 5 \text{ A ; } V_{sc} = I_1 Z_{01} = 5 \times 40 = 200 \text{ V}$$

$$\text{Short circuit p.f.} = R_{01}/Z_{01} = 20.9/40 = 0.52$$

**Example 32.36.** Obtain the equivalent circuit of a 200/400-V, 50-Hz, 1-phase transformer from the following test data :

O.C test : 200 V, 0.7 A, 70 W – on L.V. side

S.C. test : 15 V, 10 A, 85 W – on H.V. side

Calculate the secondary voltage when delivering 5 kW at 0.8 p.f. lagging, the primary voltage being 200V. **(Electrical Machinery-I, Madras Univ. 1987)**

**Solution. From O.C. Test**

$$V_1 I_0 \cos \phi_0 = W_0$$

$$\therefore 200 \times 0.7 \times \cos \phi_0 = 70$$

$$\cos \phi_0 = 0.5 \text{ and } \sin \phi_0 = 0.866$$

$$I_w = I_0 \cos \phi_0 = 0.7 \times 0.5 = 0.35 \text{ A}$$

$$I_\mu = I_0 \sin \phi_0 = 0.7 \times 0.866 = 0.606 \text{ A}$$

$$R_0 = V_1 / I_w = 200 / 0.35 = 571.4 \Omega$$

$$X_0 = V_1 / I_\mu = 200 / 0.606 = 330 \Omega$$

As shown in Fig. 32.48, these values refer to primary i.e. low-voltage side.

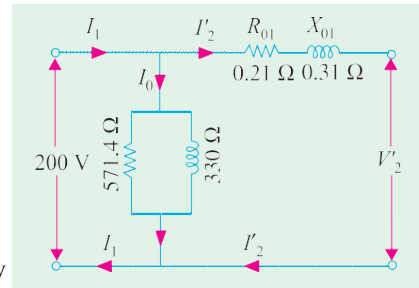

Fig. 32.48

**From S.C. Test**

It may be noted that in this test, instruments have been placed in the secondary i.e. high-voltage winding whereas the low-voltage winding i.e. primary has been short-circuited.

Now, as shown in Art. 32.32

$$Z_{02} = V_{sc} / I_2 = 15 / 10 = 1.5 \Omega ; K = 400 / 200 = 2$$

$$Z_{01} = Z_{02} / K^2 = 1.5 / 4 = 0.375 \Omega$$

Also

$$I_2^2 R_{02} = W ; R_{02} = 85 / 100 = 0.85 \Omega$$

$$R_{01} = R_{02} / K^2 = 0.85 / 4 = 0.21 \Omega$$

$$X_{01} = \sqrt{Z_{01}^2 - R_{01}^2} = \sqrt{0.375^2 - 0.21^2} = 0.31 \Omega$$

$$\text{Output kVA} = 5 / 0.8 ; \text{ Output current } I_2 = 5000 / 0.8 \times 400 = 15.6 \text{ A}$$

This value of  $I_2$  is approximate because  $V_2$  (which is to be calculated as yet) has been taken equal to 400 V (which, in fact, is equal to  $E_2$  or  ${}_0V_2$ ).

Now,  $Z_{02} = 1.5 \Omega, R_{02} = 0.85 \Omega \therefore X_{02} = \sqrt{1.5^2 - 0.85^2} = 1.24 \Omega$

Total transformer drop as referred to secondary

$$= I_2 (R_{02} \cos \phi_2 + X_{02} \sin \phi_2) = 15.6 (0.85 \times 0.8 + 1.24 \times 0.6) = 22.2 \text{ V}$$

$$\therefore V_2 = 400 - 22.2 = \mathbf{377.8 \text{ V}}$$

**Example 32.37.** Starting from the ideal transformer, obtain the approximate equivalent circuit of a commercial transformer in which all the constants are lumped and represented on one side.

A 1-phase transformer has a turn ratio of 6. The resistance and reactance of primary winding are 0.9  $\Omega$  and 5  $\Omega$  respectively and those of the secondary are 0.03  $\Omega$  and 0.13  $\Omega$  respectively. If 330 -V at 50-Hz be applied to the high voltage winding with the low-voltage winding short-circuited, find the current in the low-voltage winding and its power factor. Neglect magnetising current.

**Solution.** Here  $K = 1/6$ ;  $R_{01} = R_1 + R_2' = 0.9 + (0.03 \times 36) = 1.98 \Omega$   
 $X_{01} = X_1 + X_2' = 5 + (0.13 \times 36) = 9.68 \Omega$   
 $\therefore Z_{01} = \sqrt{(9.68^2 + 1.98^2)} = 9.9 \Omega$ ;  $V_{SC} = 330 \text{ V}$   
 $\therefore$  Full-load primary current  $I_1 = V_{sc}/Z_{01} = 330/9.9 = 100/3 \text{ A}$  As  $I_0$   
 is negligible, hence  $I_1 = I_2 = 100/3 \text{ A}$ . Now,  $I_2' = KI_2$   
 F.L. secondary current  $I_2 = I_2'K = (100/3) \times 6 = 200 \text{ A}$   
 Now, Power input on short-circuit  $= V_{sc} I_1 \cos \phi_{sc} = \text{Cu loss} = I_1^2 R_{01}$   
 $\therefore (100/3)^2 \times 1.98 = 330 \times (100/3) \times \cos \phi_{sc}$ ;  $\cos \phi_{sc} = 0.2$

**Example 32.38.** A 1-phase, 10-kVA, 500/250-V, 50-Hz transformer has the following constants:

Reactance : primary  $0.2 \Omega$ ; secondary  $0.5 \Omega$

Resistance : primary  $0.4 \Omega$ ; secondary  $0.1 \Omega$

Resistance of equivalent exciting circuit referred to primary,  $R_0 = 1500 \Omega$

Reactance of equivalent exciting circuit referred to primary,  $X_0 = 750 \Omega$

What would be the reading of the instruments when the transformer is connected for the open-circuit and short-circuit tests ?

**Solution.** While solving this question, reference may please be made to Art. 30.20 and 30.22.

**O.C. Test**

$$I_\mu = V_1/X_0 = 500/750 = 2/3 \text{ A}; I_w = V_1/R_0 = 500/1500 = 1/3 \text{ A}$$

$$\therefore I_0 = \sqrt{[(1/3)^2 + (2/3)^2]} = 0.745 \text{ A}$$

$$\text{No-load primary input} = V_1 I_w = 500 \times 1/3 = 167 \text{ W}$$

Instruments used in primary circuit are : voltmeter, ammeter and wattmeter, their readings being 500 V, 0.745 A and 167 W respectively.

**S.C. Test**

Suppose S.C. test is performed by short-circuiting the l.v. winding i.e. the secondary so that all instruments are in primary.

$$R_{01} = R_1 + R_2/K^2 = R_1 + R_2/K^2; \text{ Here } K = 1/2 \quad \therefore R_{01} = 0.2 + (4 \times 0.5) = 2.2 \Omega$$

$$\text{Similarly, } X_{01} = X_1 + X_2' = 0.4 + (4 \times 0.1) = 0.8 \Omega$$

$$Z_{01} = \sqrt{(2.2^2 + 0.8^2)} = 2.341 \Omega$$

Full-load primary current

$$I_1 = 10,000/500 = 20 \text{ A} \quad \therefore V_{SC} = I_1 Z_{01} = 20 \times 2.341 = 46.8 \text{ V}$$

$$\text{Power absorbed} = I_1^2 R_{01} = 20^2 \times 2.2 = 880 \text{ W}$$

Primary instruments will read : **46.8 V, 20 A, 880 W.**

**Example 32.39.** The efficiency of a 1000-kVA, 110/220 V, 50-Hz, single-phase transformer, is 98.5 % at half full-load at 0.8 p.f. leading and 98.8 % at full-load unity p.f. Determine (i) iron loss (ii) full-load copper loss and (iii) maximum efficiency at unity p.f.

(Elect. Engg. AMIETE Sec. A Dec. 1991)

**Solution.** Output at F.L. unity p.f. =  $1000 \times 1 = 1000 \text{ kW}$

$$\text{F.L. input} = 1000/0.988 = 1012.146 \text{ kW}$$

$$\text{F.L. losses} = 1012.146 - 1000 = 12.146 \text{ kW}$$

If F.L. Cu and iron losses are  $x$  and  $y$  respectively then

$$x + y = 12.146 \text{ kW}$$

...(i)

Input at half F.L. 0.8 p.f. =  $500 \times 0.8/0.985 = 406.091$  kW  
 Total losses at half F.L. =  $406.091 - 400 = 6.091$  kW  
 Cu loss at half-load =  $x (1/2)^2 = x/4$   
 $\therefore x/4 + y = 6.091$  ...**(ii)**  
 From Eqn. **(i)** and **(ii)**, we get **(i)**  $x = 8.073$  kW and **(ii)**  $y = 4.073$  kW  
**(iii)** kVA for  $\eta_{max} = 1000 \times \sqrt{4.073/8.073} = 710.3$  kVA  
 Output at u.p.f. =  $710.3 \times 1 = 710.3$  kW  
 Cu loss = iron loss =  $4.037$  kW ; Total loss =  $2 \times 4.037 = 8.074$  kW  
 $\therefore \eta_{max} = 710.3/(710.3 + 8.074) = 0.989$  or 98.9 %

**Example 32.40.** The equivalent circuit for a 200/400-V step-up transformer has the following parameters referred to the low-voltage side.

Equivalent resistance =  $0.15 \Omega$  ; Equivalent reactance =  $0.37 \Omega$   
 Core-loss component resistance =  $600 \Omega$  ; Magnetising reactance =  $300 \Omega$

When the transformer is supplying a load at 10 A at a power factor of 0.8 lag, calculate (i) the primary current (ii) secondary terminal voltage. (**Electrical Machinery-I, Bangalore Univ. 1989**)

**Solution.** We are given the following :

$$R_{01} = 0.15 \Omega, X_{01} = 0.37 \Omega ; R_0 = 600 \Omega, X_0 = 300 \Omega$$

Using the approximate equivalent circuit of Fig. 32.41, we have,

$$I_\mu = V_1/X_0 = 200/300 = (2/3) \text{ A}$$

$$I_w = V_1/R_0 = 200/600 = (1/3) \text{ A}$$

$$I_0 = \sqrt{I_\mu^2 + I_w^2} = \sqrt{(2/3)^2 + (1/3)^2} = 0.745 \text{ A}$$

As seen from Fig. 32.49

$$\tan \theta = \frac{I_w}{I_\mu} = \frac{1/3}{2/3} = \frac{1}{2} ; \theta = 26.6^\circ$$

$\therefore \phi_0 = 90^\circ - 26.6^\circ = 63.4^\circ$  ; Angle between  $I_0$  and

$$I_2' = \frac{63.4^\circ - 36.9^\circ}{2} = 26.5^\circ ; K = 400/200 = 2$$

$$I_2' = KI = \frac{2 \times 10}{2} = 10 \text{ A}$$

**(i)**  $I_1 = (0.745 + 10 + 2 \times 0.745 \times 10 \times \cos 26.5^\circ)$   
 $= 20.67 \text{ A}$

**(ii)**  $R_{02} = K^2 R_{01} = 2^2 \times 0.15 = 0.6 \Omega$   
 $X_{02} = 22 \times 0.37 = 1.48 \Omega$

Approximate voltage drop

$$= I_2 (R_{02} \cos \phi + X_{02} \sin \phi)$$

$$= 10 (0.6 \times 0.8 + 1.48 \times 0.6) = 13.7 \text{ V}$$

$\therefore$  Secondary terminal voltage =  $400 - 13.7$   
 $= 386.3 \text{ V}$

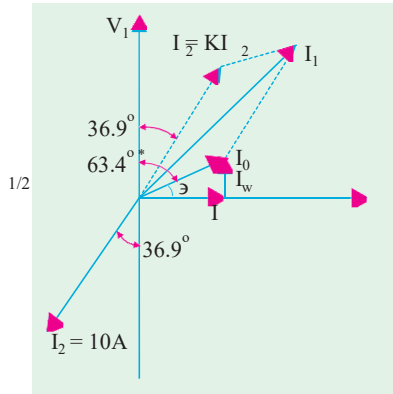

Fig. 32.49

**Example 32.41.** The low voltage winding of a 300-kVA, 11,000/2500-V, 50-Hz transformer has 190 turns and a resistance of 0.06. The high-voltage winding has 910 turns and a resistance of 1.6 Ω. When the l.v. winding is short-circuited, the full-load current is obtained with 550-V applied to the h.v. winding. Calculate (i) the equivalent resistance and leakage reactance as referred to h.v. side and (ii) the leakage reactance of each winding.

**Solution.** Assuming a full-load efficiency of 0.985, the full-load primary current is



$$\begin{aligned}
 &= 300,000/0.985 \times 11,000 = 27.7\text{A} \\
 \therefore Z_{01} &= 550/27.7 = 19.8 \Omega ; R_2' = R/K^2 = 0.06 (910/190)^2 = 1.38 \Omega \\
 \therefore R_{01} &= R_1 + R_2' = 1.6 + 1.38 = 2.98 \Omega \\
 X_{01} &= \sqrt{(Z_{01}^2 - R_{01}^2)} = \sqrt{(19.8^2 - 2.98^2)} = 19.5 \Omega
 \end{aligned}$$

Let us make another assumption that for each winding the ratio (reactance/resistance) is the same, then

$$\begin{aligned}
 X_1 &= 19.5 \times 1.6/2.98 = 10.5 \Omega \\
 X_2' &= 19.5 \times 1.38/2.98 = 9.0 \Omega ; X_2 = 9(190/910)^2 = 0.39 \Omega \\
 (a) \quad R_{01} &= 2.98 \Omega ; X_{01} = 19.5 \Omega \quad (b) \quad X_1 = 10.5 \Omega ; X_2 = 0.39 \Omega
 \end{aligned}$$

**Example 32.42.** A 230/115 volts, single phase transformer is supplying a load of 5 Amps, at power factor 0.866 lagging. The no-load current is 0.2 Amps at power factor 0.208 lagging. Calculate the primary current and primary power factor.

(Nagpur University Summer 2000)

**Solution.** L.V. current of 5 amp is referred to as a 2.5 amp current on the primary (= H.V.) side, at 0.866 lagging p.f. To this, the no load current should be added, as per the phasor diagram in Fig. 32.50. The phase angle of the load-current is 30° lagging. The no load current has a phase angle of 80° lagging. Resultant of these two currents has to be worked out. Along the reference, active components are added.

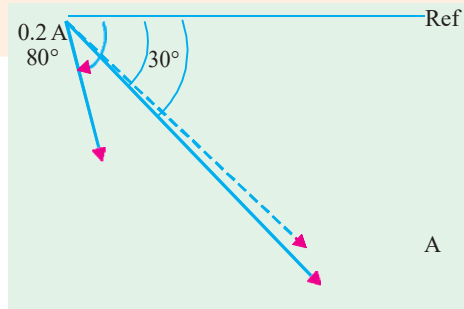

I  
1

Active components of currents =  
 $2.5 \times 0.866 + 0.2 \times 0.208$

Fig. 32.50. Phasor diagram for Currents

$$\begin{aligned}
 &= 2.165 + 0.0416 \\
 &= 2.2066 \text{ amp}
 \end{aligned}$$

Along the perpendicular direction, the reactive components get added up.

$$\begin{aligned}
 \text{Reactive component} &= 2.5 \times 0.5 + 0.2 \times 0.9848 \\
 &= 1.25 + 0.197 = 1.447 \text{ amp.}
 \end{aligned}$$

$$I_1 = 2.2066 - j 1.447$$

$$\phi = \tan^{-1} \frac{1.447}{2.2066} = 33.25^\circ ; \text{ as shown}$$

### Tutorial Problems 32.3

1. The S.C. test on a 1-phase transformer, with the primary winding short-circuited and 30 V applied to the secondary gave a wattmeter reading of 60 W and secondary current of 10 A. If the normal applied primary voltage is 200, the transformation ratio 1 :2 and the full-load secondary current 10 A, calculate the secondary terminal p.d. at full-load current for (a) unity power factor (b) power factor 0.8 lagging. If any approximations are made, they must be explained. **[394 V, 377.6 V]**
2. A single-phase transformer has a turn ratio of 6, the resistances of the primary and secondary windings are 0.9  $\Omega$  and 0.025  $\Omega$  respectively and the leakage reactances of these windings are 5.4  $\Omega$  and 0.15  $\Omega$  respectively. Determine the voltage to be applied to the low-voltage winding to obtain a current of 100 A in the short-circuited high voltage winding. Ignore the magnetising current. **[82 V]**
3. Draw the equivalent circuit for a 3000/400-V, 1-phase transformer on which the following test results were obtained. Input to high voltage winding when l.v. winding is open-circuited : 3000 V, 0.5 A, 500

W. Input to l.v. winding when h.v. winding is short-circuited : 11 V, 100 A, 500 W. Insert the appropriate values of resistance and reactance.

[ $R_0 = 18,000 \Omega$ ,  $X_0 = 6,360 \Omega$ ,  $R_{01} = 2.81 \Omega$ ,  $X_{01} = 5.51 \Omega$ ] (*I.E.E. London*)

4. The iron loss in a transformer core at normal flux density was measured at frequencies of 30 and 50 Hz, the results being 30 W and 54 W respectively. Calculate (a) the hysteresis loss and (b) the eddy current loss at 50 Hz. [44 W, 10 W]
5. An iron core was magnetised by passing an alternating current through a winding on it. The power required for a certain value of maximum flux density was measured at a number of different frequencies. Neglecting the effect of resistance of the winding, the power required per kg of iron was 0.8 W at 25 Hz and 2.04 W at 60 Hz. Estimate the power needed per kg when the iron is subject to the same maximum flux density but the frequency is 100 Hz. [3.63 W]
6. The ratio of turns of a 1-phase transformer is 8, the resistances of the primary and secondary windings are  $0.85 \Omega$  and  $0.012 \Omega$  respectively and leakage reactances of these windings are  $4.8 \Omega$  and  $0.07 \Omega$  respectively. Determine the voltage to be applied to the primary to obtain a current of 150 A in the secondary circuit when the secondary terminals are short-circuited. Ignore the magnetising current. [176.4 W]
7. A transformer has no-load losses of 55 W with a primary voltage of 250 V at 50 Hz and 41 W with a primary voltage of 200 V at 40 Hz. Compute the hysteresis and eddy current losses at a primary voltage of 300 volts at 60 Hz of the above transformer. Neglect small amount of copper loss at no-load. [43.5 W ; 27 W] (*Elect. Machines AMIE Sec. B. (E-3) Summer 1992*)
8. A 20 kVA, 2500/250 V, 50 Hz, 1-phase transformer has the following test results :  
O.C. Test (l.v. side) : 250 V, 1.4 A, 105 W  
S.C. Test (h.v. side) : 104 V, 8 A, 320 W  
Compute the parameters of the approximate equivalent circuit referred to the low voltage side and draw the circuit. ( $R_0 = 592.5 \Omega$  ;  $X_0 = 187.2 \Omega$  ;  $R_{02} = 1.25 \Omega$  ;  $X_{12} = 3 \Omega$ ) (*Elect. Machines A.M.I.E. Sec. B Summer 1990*)
9. A 10-kVA, 2000/400-V, single-phase transformer has resistances and leakage reactances as follows :  
 $R_1 = 5.2 \Omega$ ,  $X_1 = 12.5 \Omega$ ,  $R_2 = 0.2 \Omega$ ,  $X_2 = 0.5 \Omega$   
Determine the value of secondary terminal voltage when the transformer is operating with rated primary voltage with the secondary current at its rated value with power factor 0.8 lag. The no-load current can be neglected. Draw the phasor diagram. [376.8 V] (*Elect. Machines, A.M.I.E. Sec B, 1989*)
10. A 1000-V, 50-Hz supply to a transformer results in 650 W hysteresis loss and 400 W eddy current loss. If both the applied voltage and frequency are doubled, find the new core losses. [ $W_h = 1300 \text{ W}$  ;  $W_e = 1600 \text{ W}$ ] (*Elect. Machine, A.M.I.E. Sec. B, 1993*)
11. A 50 kVA, 2200/110 V transformer when tested gave the following results :  
O.C. test (L.V. side) : 400 W, 10 A, 110 V.  
S.C. test (H.V. side) : 808 W, 20.5 A, 90 V.  
Compute all the parameters of the equivalent ckt. referred to the H.V. side and draw the resultant ckt. (*Rajiv Gandhi Technical University, Bhopal 2000*)

[Shunt branch :  $R_0 = 12.1 \text{ k-ohms}$ ,  $X_m = 4.724 \text{ k-ohms}$  Series branch :  $r = 1.923 \text{ ohms}$ ,  $x = 4.39 \text{ ohms}$ ]

### Regulation of a Transformer

1. When a transformer is loaded with a *constant primary voltage*, the secondary voltage decreases\* because of its internal resistance and leakage reactance.

Let  ${}_0V_2$  = secondary terminal voltage at no-load.

---

\* Assuming lagging power factor. It will increase if power factor is leading.

$= E_2 = EK_1 = K V_1$  because at no-load the impedance drop is negligible.

$V_2 =$  secondary terminal voltage on *full-load*.

The change in secondary terminal voltage from no-load to full-load is  $= {}_0V_2 - V_2$ . This change divided by  ${}_0V_2$  is known as regulation 'down'. If this change is divided by  $V_2$ , *i.e.*, full-load secondary terminal voltage, then it is called regulation 'up'.

$$\therefore \quad \% \text{ regn 'down'} = \frac{{}_0V_2 - V_2}{{}_0V_2} \times 100 \text{ and } \% \text{ regn 'up'} = \frac{{}_0V_2 - V_2}{V_2} \times 100$$

In further treatment, unless stated otherwise, regulation is to be taken as regulation 'down'.

We have already seen in Art. 32.16 (Fig. 32.35) that the change in secondary terminal voltage from no-load to full-load, expressed as a percentage of no-load secondary voltage is,

$$= v_r \cos \phi \pm v_x \sin \phi \quad \text{(approximately)}$$

Or more accurately

$$= (v_r \cos \phi \pm v_x \sin \phi) + \frac{1}{200} (v_x \cos \phi \pm v_r \sin \phi)^2$$

$$\therefore \quad \% \text{ regn} = v_r \cos \phi \pm v_x \sin \phi \quad \dots \text{approximately.}$$

The lesser this value, the better the transformer, because a good transformer should keep its secondary terminal voltage as constant as possible under all conditions of load.

(2) The regulation may also be explained in terms of primary values.

In Fig. 32.51 (a) the approximate equivalent circuit of a transformer is shown and in Fig. 32.51 (b), (c) and (d) the vector diagrams corresponding to different power factors are shown.

The secondary *no-load* terminal voltage as referred to primary is  $E'_2 = E_2/K = E_1 = V_1$  and if the secondary full-load voltage as referred to primary is  $V'_2 = V_2/K$  then

$$\% \text{ regn} = \frac{V_1 - V'_2}{V_1} \times 100$$

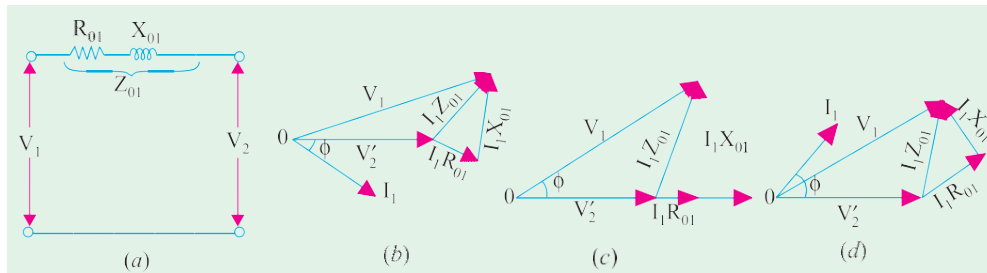

Fig. 32.51

From the vector diagram, it is clear that if angle between  $V_1$  and  $V'_2$ s neglected, then the value of numerical difference  $V_1 - V'_2$ s given by  $(I_1 R_{01} \cos \phi + I_1 X_{01} \sin \phi)$  for lagging p.f.

$$\therefore \quad \% \text{ regn} = \frac{I_1 R_{01} \cos \phi + I_1 X_{01} \sin \phi}{V_1} \times 100 = v_r \cos \phi + v_x \sin \phi$$

where  $\frac{I_1 R_{01} \times 100}{V_1} = v_r$  and  $\frac{I_1 X_{01} \times 100}{V_1} = v_x$  ...Art. 32.16

As before, if angle between  $V_1$  and  $V'_2$ s not negligible, then

$$\% \text{ regn} = (v_r \cos \phi \pm v_x \sin \phi) + \frac{1}{200} (v_x \cos \phi \pm v_r \sin \phi)^2 \quad \text{(v)}$$

(3) In the above definitions of regulation, *primary voltage was supposed to be kept constant* and the changes in secondary terminal voltage were considered.

As the transformer is loaded, the secondary terminal voltage falls (for a lagging p.f.). Hence, to keep the output voltage constant, the primary voltage must be increased. The rise in primary voltage required to maintain rated output voltage from no-load to full-load at a given power factor expressed as percentage of rated primary voltage gives the regulation of the transformer.

Suppose primary voltage has to be raised from its rated value  $V_1$  to  $V_1'$ , then

$$\% \text{ regn.} = \frac{V_1' - V_1}{V_1} \times 100$$

**Example 32.43.** A-100 kVA transformer has 400 turns on the primary and 80 turns on the secondary. The primary and secondary resistances are  $0.3 \Omega$  and  $0.01 \Omega$  respectively and the corresponding leakage reactances are  $1.1$  and  $0.035 \Omega$  respectively. The supply voltage is  $2200 \text{ V}$ . Calculate (i) equivalent impedance referred to primary and (ii) the voltage regulation and the secondary terminal voltage for full load having a power factor of  $0.8$  leading.

(Elect. Machines, A.M.I.E. Sec. B, 1989)

**Solution.**  $K = 80/400 = 1/5$ ,  $R_1 = 0.3 \Omega$ ,  $R_{01} = R_1 + R_2/K^2 = 0.3 + 0.01/(1/5)^2 = 0.55 \Omega$

$$X_{01} = X_1 + X_2/K = 1.1 + 0.035/(1/5) = 1.975 \Omega$$

$$(i) \quad Z_{01} = 0.55 + j 1.975 = 2.05 \angle 74.44^\circ$$

$$(ii) \quad Z_{02} = K^2 Z_{01} = (1/5)^2 (0.55 + j 1.975) = (0.022 + j 0.079)$$

$$\text{No-load secondary voltage} = K V_1 = (1/5) \times 2200 = 440 \text{ V}, I_2 = 10 \times 10 / 440 = 227.3 \text{ A}$$

Full-load voltage drop as referred to secondary

$$= I_2 (R_{02} \cos \phi - X_{02} \sin \phi)$$

$$= 227.3 (0.022 \times 0.8 - 0.079 \times 0.6) = -6.77 \text{ V}$$

$$\% \text{ regn.} = -6.77 \times 100/440 = -1.54$$

$$\text{Secondary terminal voltage on load} = 440 - (-6.77) = 446.77 \text{ V}$$

**Example 32.44.** The corrected instrument readings obtained from open and short-circuit tests on 10-kVA, 450/120-V, 50-Hz transformer are :

O.C. test :  $V_1 = 120 \text{ V}$ ;  $I_1 = 4.2 \text{ A}$ ;  $W_1 = 80 \text{ W}$ ;  $V_1$ ,  $W_1$  and  $I_1$  were read on the low-voltage side.

S.C. test :  $V_1 = 9.65 \text{ V}$ ;  $I_1 = 22.2 \text{ A}$ ;  $W_1 = 120 \text{ W}$  – with low-voltage winding short-circuited

Compute :

- (i) the equivalent circuit (approximate) constants,
- (ii) efficiency and voltage regulation for an 80% lagging p.f. load,
- (iii) the efficiency at half full-load and 80% lagging p.f. load.

(Electrical Engineering-I, Bombay Univ. 1988)

**Solution.** It is seen from the O.C. test, that with primary open, the secondary draws a no-load current of  $4.2 \text{ A}$ . Since  $K = 120/450 = 4/15$ , the corresponding no-load primary current  $I_0 = 4.2 \times 4/15 = 1.12 \text{ A}$ .

$$(i) \quad \text{Now, } V_1 I_0 \cos \phi_0 = 80 \therefore \cos \phi_0 = 80/450 \times 1.12 = 0.159$$

$$\therefore \phi_0 = \cos^{-1}(0.159) = 80.9^\circ; \sin \phi_0 = 0.987$$

$$I_w = I_0 \cos \phi_0 = 1.12 \times 0.159 = 0.178 \text{ A and } I_\mu = 1.12 \times 0.987 = 1.1 \text{ A}$$

$$\therefore R_0 = 450/0.178 = 2530 \Omega \text{ and } X_0 = 450/1.1 = 409 \Omega$$

During S.C. test, instruments have been placed in primary.

$$\therefore Z_{01} = 9.65/22.2 = 0.435 \Omega$$

$$R_{01} = 120/22.2^2 = 0.243 \Omega$$

$$X_{01} = \sqrt{0.435^2 - 0.243^2} = 0.361 \Omega$$

The equivalent circuit is shown in Fig. 32.52.

(ii) Total approximate voltage drop as referred to primary is  $I_1 (R_{01} \cos \phi + X_{01} \sin \phi)$ .

\* Assuming  $\phi_1 = \phi_2 = \cos^{-1}(0.8)$ .

Now, full-load  $I_1 = 10,000/450 = 22.2$  A  
 $\therefore$  Drop =  $22.2 (0.243 \times 0.8 + 0.361 \times 0.6) = 9.2$  V  
 Regulation =  $9.2 \times 100/450 = 2.04\%$   
 F.L. losses =  $80 + 120 = 200$  W;  
 F.L. output =  $10,000 \times 0.8 = 8000$  W  
 $\eta = 8000/8200 = 0.9757$  or **97.57%**

(ii) Half-load  
 Iron loss =  $80$  W; Cu loss =  $(1/2)^2 \times 120 = 30$  W  
 Total losses =  $110$  W; Output =  $5000 \times 0.8 = 4000$  W  
 $\therefore \eta = 4000/4110 = 0.9734$  or **97.34%**

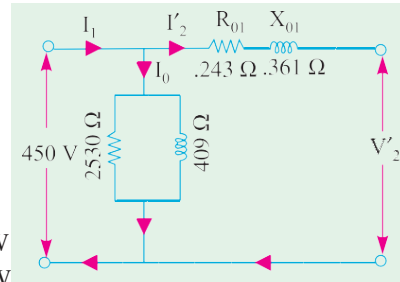

Fig. 32.52

**Example 32.45.** Consider a 20 kVA, 2200/220 V, 50 Hz transformer. The O.C./S.C. test results are as follows :

O.C. test : 220 V, 4.2 A, 148 W (l.v. side)

S.C. test : 86 V, 10.5 A, 360 W (h.v. side)

Determine the regulation at 0.8 p.f. lagging and at full load. What is the p.f. on short-circuit ?

(Elect. Machines Nagpur Univ. 1993)

**Solution.** It may be noted that O.C. data is not required in this question for finding the regulation. Since during S.C. test instruments have been placed on the h.v. side i.e. primary side.

$$\therefore Z_{01} = 86/10.5 = 8.19 \Omega; R_{01} = 360/10.5^2 = 3.26 \Omega$$

$$X_{01} = \sqrt{8.19^2 - 3.26^2} = 7.5 \Omega$$

F.L. primary current,  $I_1 = 20,000/2200 = 9.09$  A

Total voltage drop as referred to primary =  $I_1 (R_{01} \cos \phi + X_{01} \sin \phi)$

Drop =  $9.09 (3.26 \times 0.8 + 7.5 \times 0.6) = 64.6$  V

% age regn. =  $64.6 \times 100/2200 = 2.9\%$ , p.f. on short-circuit =  $R_{01}/Z_{01} = 3.26/8.19 = 0.4$  lag

**Example 32.46.** A short-circuit test when performed on the h.v. side of a 10 kVA, 2000/400 V single phase transformer, gave the following data ; 60 V, 4 A, 100 W.

If the l.v. side is delivering full load current at 0.8 p.f. lag and at 400 V, find the voltage applied to h.v. side.

(Elect. Machines-I, Nagpur Univ. 1993)

**Solution.** Here, the test has been performed on the h.v. side i.e. primary side.

$$Z_{01} = 60/4 = 15 \Omega; R_{01} = 100/4^2 = 6.25 \Omega; X_{01} = \sqrt{15^2 - 6.25^2} = 13.63 \Omega$$

F.L.  $I_1 = 10,000/2000 = 5$  A

Total transformer voltage drop as referred to primary is

$$I_1 (R_{01} \cos \phi + X_{01} \sin \phi) = 5 (6.25 \times 0.8 + 13.63 \times 0.6) = 67$$
 V

Hence, primary voltage has to be raised from 2000 V to 2067 V in order to compensate for the total voltage drop in the transformer. In that case secondary voltage on load would remain the same as on no-load.

**Example 32.47.** A 250/500-V transformer gave the following test results :

Short-circuit test : with low-voltage winding short-circuited :

20 V; 12 A, 100 W

Open-circuit test : 250 V, 1 A, 80 W on low-voltage side.

Determine the circuit constants, insert these on the equivalent circuit diagram and calculate applied voltage and efficiency when the output is 10 A at 500 volt and 0.8 power factor lagging.

(Elect. Machines, Nagpur Univ. 1993)

**Solution. Open-circuit Test :**

$$V_1 I_0 \cos \phi_0 = 80 \quad \therefore \cos \phi_0 = 80/250 \times I = 0.32$$

$$I_w = I_0 \cos \phi_0 = I \times 0.32 = 0.32 \text{ A}, I_\mu = \sqrt{(1^2 - 0.32^2)} = 0.95 \text{ A}$$

$$R_0 = V_1 / I_w = 250/0.32 = 781.3 \Omega, X_0 = V_1 / I_\mu = 250/0.95 = 263.8 \Omega$$

The circuit is shown in Fig. 32.53 (a).

**Short-circuit Test :**

As the primary is short-circuited, all values refer to secondary winding.

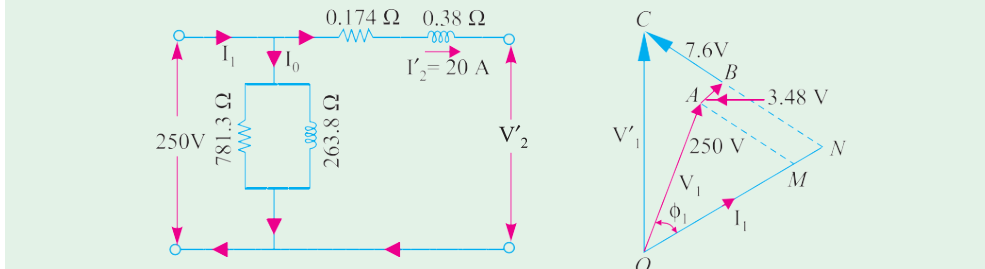

Fig. 32.53 (a)

Fig. 32.53 (b)

$$\therefore R_{02} = \frac{\text{short-circuit power}}{\text{F.L. secondary current}} = \frac{100}{12^2} = 0.694 \Omega$$

$$Z_{02} = 20/12 = 1.667 \Omega; X_{02} = \sqrt{(1.667^2 - 0.694^2)} = 1.518 \Omega$$

As  $R_0$  and  $X_0$  refer to primary, hence we will transfer these values to primary with the help of transformation ratio.

$$K = 500/250 = 2 \therefore R_{01} = R_{02}/K^2 = 0.694/4 = 0.174 \Omega$$

$$X_{01} = X_{02}/K^2 = 1.518/4 = 0.38 \Omega; Z_{01} = Z_{02}/K^2 = 1.667/4 = 0.417 \Omega$$

The equivalent circuit is shown in Fig. 32.53 (a).

**Efficiency**

$$\text{Total Cu loss} = I_2^2 R_{02} = 100 \times 0.694 = 69.4 \text{ W}; \text{Iron loss} = 80 \text{ W}$$

$$\text{Total loss} = 69.4 + 80 = 149.4 \text{ W} \quad \therefore \eta = \frac{5000 \times 0.8 \times 100}{4000 + 149.4} = 96.42\%$$

The applied voltage  $V_1$  is the vector sum of  $V_1'$  and  $I_1 Z_{01}$  as shown in Fig. 32.53 (b).

$$I_1 = 20 \text{ A}; I_1 R_{01} = 20 \times 0.174 = 3.48 \text{ V}; I_1 X_{01} = 20 \times 0.38 = 7.6 \text{ V}$$

Neglecting the angle between  $V_1$  and  $V_1'$ , we have

$$V_1^2 = OC^2 = ON^2 + NC^2 = (OM + MN)^2 + (NB + BC)^2$$

$$= (250 \times 0.8 + 3.48)^2 + (250 \times 0.6 + 7.6)^2$$

$$V_1^2 = 203.5^2 + 157.6^2 \quad \therefore V_1 \approx 257.4 \text{ V}$$

**Example 32.48.** A 230/230 V, 3 kVA transformer gave the following results :

O.C. Test: 230 V, 2 amp, 100 W

S.C. Test: 15 V, 13 amp, 120 W

Determine the regulation and efficiency at full load 0.80 p.f. lagging.

(Sambalpur University, 1998)

**Solution.** This is the case of a transformer with turns ratio as 1 : 1. Such a transformer is mainly required for isolation.

$$\text{Rated Current} = \frac{3000}{230} = 13 \text{ amp}$$

Cu-losses at rated load = 120 watts, from S.C. test

Core losses = 100 watts, from O.C. test

At full load, VA output = **3000**

At 0.8 lag p.f., Power output =  $3000 \times 0.8 = 2400$  watts

$$\text{Required efficiency} = \frac{2400}{2400 + 220} \times 100\% = 91.6\%$$

From S.C. test,  $Z = \frac{15}{13} = 1.154$  ohms

$$R = \frac{120}{15 \times 15} = 0.53 \text{ ohm}, \quad X = \sqrt{1.154^2 - 0.53^2} = 1.0251 \text{ ohm}$$

Approximate voltage regulation

$$\begin{aligned} &= IR \cos \phi + IX \sin \phi = 13[0.53 \times 0.8 + 1.0251 \times 0.6] \\ &= 13[0.424 + 0.615] = 13.51 \text{ volts} \end{aligned}$$

In terms of %, the voltage regulation =  $\frac{13.51}{230} \times 100\% = \mathbf{5.874\%}$

**Example 32.49.** A 10 kVA, 500/250 V, single-phase transformer has its maximum efficiency of 94% when delivering 90% of its rated output at unity p.f. Estimate its efficiency when delivering its full-load output at p.f. of 0.8 lagging. (Nagpur University, November 1998)

**Solution.** Rated output at unity p.f. = 10000 W. Hence, 90% of rated output = 9,000 W

Input with 94% efficiency =  $9000/0.94$  W

$$\text{Losses} = 9000((1/0.94) - 1) = 574 \text{ W}$$

At maximum efficiency, variable copper-loss = constant = Core loss =  $574/2 = 287$  W

At rated current, Let the copper-loss =  $P_c$  watts

At 90% load with unity p.f., the copper-loss is expressed as  $0.90^2 \times P_c$ .

Hence,  $P_c = 287/0.81 = 354$  W

(b) Output at full-load, 0.8 lag p.f. =  $10,000 \times 0.80 = 8000$  W

At the corresponding load, Full Load copper-loss = 354 W

Hence, efficiency =  $8000/(8000 + 354 + 287) = 0.926 = \mathbf{92.6\%}$

**Example 32.50.** Resistances and Leakage reactance of 10 kVA, 50 Hz, 2300/230 V single phase distribution transformer are  $r_1 = 3.96$  ohms,  $r_2 = 0.0396$  ohms,  $x_1 = 15.8$  ohms,  $x_2 = 0.158$  ohm. Subscript 1 refers to HV and 2 to LV winding (a) transformer delivers rated kVA at 0.8 p.f. Lagging to a load on the L.V. side. Find the H.V. side voltage necessary to maintain 230 V across Load-terminals. Also find percentage voltage regulation. (b) Find the power-factor of the rated load-current at which the voltage regulation will be zero, hence find the H.V. side voltage.

(Nagpur University, November 1997)

**Solution.** (a) Rated current on L.V. side =  $10,000/230 = 43.5$  A. Let the total resistance and total leakage reactance be referred to L.V. side. Finally, the required H.V. side voltage can be worked out after transformation.

Total resistance, 
$$\begin{aligned} r &= r_1 + r_2 = 3.96 \times (230/2300)^2 + 0.0396 \\ &= 0.0792 \text{ ohms} \end{aligned}$$

Total leakage-reactance, 
$$\begin{aligned} x &= x_1 + x_2 = 15.8 \times (230/2300)^2 + 0.158 \\ &= 0.316 \text{ ohm} \end{aligned}$$



For purpose of calculation of voltage-magnitudes, approximate formula for voltage regulation can be used. For the present case of 0.8 lagging p.f.

$$\begin{aligned} V_1' &= V_2 + I[r \cos \phi + x \sin \phi] \\ &= 230 + 43.5 [(0.0792 \times 0.8) + (0.316 \times 0.6)] \\ &= 230 + 43.5 [0.0634 + 0.1896] = 230 + 11 = 241 \text{ volts} \end{aligned}$$

Hence,  $V_1 = 241 \times (2300/230) = 2410$  volts.

It means that H.V. side terminal voltage must be 2410 for keeping 230 V at the specified load.

(b) Approximate formula for voltage regulation is:  $V_1' - V_2 = I[r \cos \phi \pm x \sin \phi]$

With Lagging p.f., +ve sign is retained. With leading power-factor, the -ve sign is applicable. For the voltage-regulation to be zero, only leading P.f. condition can prevail.

Thus,  $r \cos \phi - x \sin \phi = 0$

or  $\tan \phi = r/x = 0.0792/0.316 = 0.25$

or  $\phi = 14^\circ$ ,  $\cos \phi = 0.97$  leading

Corresponding  $\sin \phi = \sin 14^\circ = 0.243$

H.V. terminal voltage required is 2300 V to maintain 230 V at Load, since Zero regulation condition is under discussion.

**Example 32.51.** A 5 kVA, 2200/220 V, single-phase transformer has the following parameters.

H.V. side :  $r_1 = 3.4$  ohms,  $x_1 = 7.2$  ohms

L.V. side :  $r_2 = 0.028$  ohms,  $x_2 = 0.060$  ohms

Transformer is made to deliver rated current at 0.8 lagging P.f. to a load connected on the L.V. side. If the load voltage is 220 V, calculate the terminal voltage on H.V. side

(Neglect the exciting current).

(Rajiv Gandhi Technical University, Bhopal, Summer 2001)

**Solution.** Calculations may be done referring all the parameters the L.V. side first. Finally, the voltage required on H.V. side can be obtained after transformation.

Rated current ref. to L.V. side =  $5000/220 = 22.73$  A

Total winding resistance ref. to L.V. side =  $r_1 + r_2 = (220/2200)^2 \times 3.4 + 0.028$

Total winding-leakage-reactance ref. to L.V. side =  $x_1 + x_2$

$$= (220/2200)^2 \times 7.2 + 0.060 = 0.132 \text{ ohm}$$

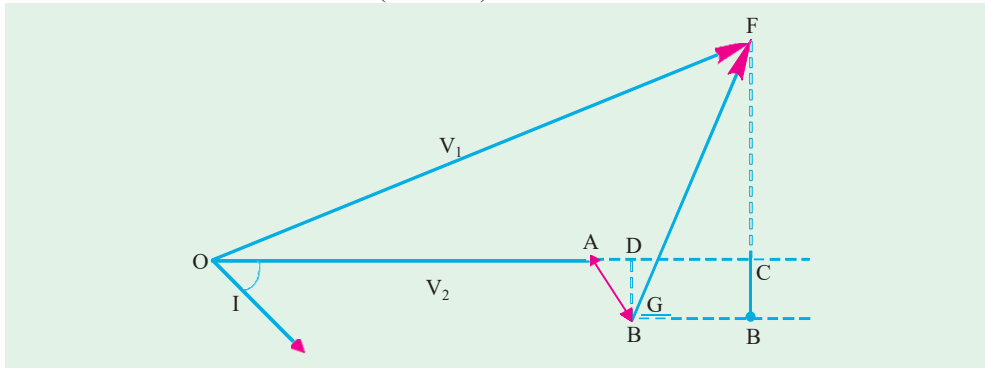

Fig. 32.53(c)

In the phasor diagram of Fig. 32.53 (c).

$QA = V_2 = 220$  volts,  $I = 22.73$  A at lagging phase angle of  $36.87^\circ$

$AB = Ir$ ,  $AD = Ir \cos \phi = 22.73 \times 0.062 \times 0.80 = 1.127$  V

$DC = Ix \sin \phi = 22.73 \times 0.132 \times 0.60 = 1.80$  V

$$OC = 220 + 1.127 + 1.80 = 222.93 \text{ volts}$$

$$BD = Ir \sin \phi = 0.85 \text{ V}$$

$$BF = x \cos \phi = 2.40 \text{ V}$$

$$CF = 2.40 - 0.85 = 1.55 \text{ V}$$

$$V_1' = OF = (222.93^2 + 1.55^2)^{0.50} = 222.935 \text{ volts}$$

Required terminal voltage of H.V. side =  $V_1 = 222.935 \times (2200/220) = 2229.35 \text{ volts}$

[Note. In approximate and fast calculations,  $CF$  is often ignored for calculation of magnitude of  $V_1'$ . The concerned expression is :  $V_1' = V_2 + Ir \cos \phi + Ix \sin \phi$ , for lagging P.f.]

**Example 32.52.** A 4-kVA, 200/400 V, single-phase transformer takes 0.7 amp and 65 W on Open-circuit. When the low-voltage winding is short-circuited and 15 V is applied to the high-voltage terminals, the current and power are 10 A and 75 W respectively. Calculate the full-load efficiency at unity power factor and full-load regulation at 0.80 power-factor lagging.

(Nagpur University April 1999)

**Solution.** At a load of 4 kVA, the rated currents are :

$$\text{L.V. side: } 4000/200 = 20 \text{ amp}$$

$$\text{And H.V. side: } 4000/400 = 10 \text{ amp}$$

From the test data, full-load copper-loss = 75 W

And constant core-loss = 65 W

$$\text{From S.C. test, } Z = 15/10 = 1.5 \text{ ohms}$$

$$R = 75/100 = 0.75 \text{ ohm}$$

$$\text{Hence } x = \sqrt{1.5^2 - 0.75^2} = 1.30 \text{ ohms}$$

All these series-parameters are referred to the H.V. side, since the S.C. test has been conducted from H.V. side.

$$\begin{aligned} \text{Full-load efficiency at unity p.f.} &= 4000 / (4000 + 65 + 75) \\ &= 0.966 = 96.6\% \end{aligned}$$

$$\begin{aligned} \text{Full load voltage regulation at 0.80 lagging p.f.} &= Ir \cos \phi + Ix \sin \phi \\ &= 10 (0.75 \times 0.80 + 1.30 \times 0.60) = 16.14 \text{ Volts} \end{aligned}$$

Thus, due to loading, H.V. side voltage will drop by 16.14 volts (*i.e.* terminal voltage for the load will be 383.86 volts), when L.V. side is energized by 200-V source.

### Percentage Resistance, Reactance and Impedance

These quantities are usually measured by the voltage drop at full-load current expressed as a percentage of the normal voltage of the winding on which calculations are made.

(i) Percentage resistance at full-load

$$\begin{aligned} \% R &= \frac{I_1 R_{01}}{V_1} \times 100 = \frac{I_1^2 R_{01}}{V_1 I_1} \times 100 \\ &= \frac{I_1^2 R}{V_2 I_2} \times 100 = \% \text{ Cu loss at full-load} \end{aligned}$$

$$\% R = \% \text{ Cu loss} = v_r \quad \dots \text{Art.32.16}$$

(ii) Percentage reactance at full-load

$$\% X = \frac{I_1 X_{01}}{V_1} \times 100 = \frac{I_2 X_{02}}{V_2} \times 100 = v_x$$

(iii) Percentage impedance at full-load

$$\% Z = \frac{I_1 Z_{01}}{V_1} \times 100 = \frac{I_2 Z_{02}}{V_2} \times 100$$

(iv)

$$\% Z = \sqrt{(\% R^2 + \% X^2)}$$

It should be noted from above that the reactances and resistances in ohm can be obtained thus :

$$R_{01} = \frac{\% R \times V_1}{100 \times I_1} = \frac{\% \text{ Cu loss} \times V_1}{100 \times I_1}; \text{ Similarly } R_{02} = \frac{\% R \times V_2}{100 \times I_2} = \frac{\% \text{ Cu loss} \times V_2}{100 \times I_2}$$

$$X_{01} = \frac{\% X \times V_1}{100 \times I_1} = \frac{v_x \times V_1}{100 \times I_1}; \text{ Similarly } X_{02} = \frac{\% X \times V_2}{100 \times I_2} = \frac{v_x \times V_2}{100 \times I_2}$$

It may be noted that percentage resistance, reactance and impedance have the same value whether referred to primary or secondary.

**Example 32.53.** A 3300/230 V, 50-kVA, transformer is found to have impedance of 4% and a Cu loss of 1.8% at full-load. Find its percentage reactance and also the ohmic values of resistance, reactance and impedance as referred to primary. What would be the value of primary short-circuit current if primary voltage is assumed constant ?

**Solution.**  $\% X = \sqrt{(\% Z^2 - \% R^2)} = \sqrt{(4^2 - 1.8^2)} = 3.57\% \text{ ( Cu loss } = \% R)$

Full load  $I_1 = 50,000/3300 = 15.2 \text{ A}$  (assuming 100% efficiency). Considering primary winding, we have

$$\% R = \frac{R_{01} I_1 \times 100}{V_L} = 1.8 \quad \therefore R_{01} = \frac{1.8 \times 3300}{100 \times 15.2} = 3.91 \Omega$$

Similarly  $\% X = \frac{X_{01} I_1 \times 100}{V_1} = 3.57 \quad \therefore X_{01} = \frac{3.57 \times 3300}{100 \times 15.2} = 7.76 \Omega$

Similarly  $Z_{01} = \frac{4 \times 3300}{100 \times 15.2} = 8.7 \Omega$

Now  $\frac{\text{Short-circuit current}^*}{\text{Full load current}} = \frac{100}{4} \quad \therefore \text{S.C. current} = 15.2 \times 25 = 380 \text{ A}$

**Example 32.54.** A 20-kVA, 2200/220-V, 50-Hz distribution transformer is tested for efficiency and regulation as follows :

O.C. test : 220 V      4.2 A, 148 W      -l.v side  
 S.C. test : 86 V      10.5 A, 360 W      -l.v side

Determine (a) core loss (b) equivalent resistance referred to primary (c) equivalent resistance referred to secondary (d) equivalent reactance referred to primary (e) equivalent reactance referred to secondary (f) regulation of transformer at 0.8 p.f. lagging current (g) efficiency at full-load and half the full-load at 0.8 p.f. lagging current.

**Solution.** (a) As shown in Art 32.9, no-load primary input is practically equal to the core loss. Hence, core loss as found from no-load test, is 148 W.

(b) From S.C. test,  $R_{01} = 360/10.5 = 3.26 \Omega$

(c)  $R_{02} = K R_{01} = \left(\frac{220}{2200}\right)^2 \times 3.26 = 0.0326 \Omega$

---

\* Short circuit  $I_{sc} = \frac{V_1}{Z_{01}}$  Now,  $Z_{01} = \frac{V_1 \times \% Z}{100 \times I_1}$   
 $I_{sc} = \frac{V_1 \times 100 \times I_1}{V_1 \times \% Z} = \frac{100 \times I_1}{\% Z} \quad \therefore \frac{I_{sc}}{I_1} = \frac{100}{\% Z}$

$$(d) \quad Z_{10} = \frac{V_{SC}}{I_{SC}} = \frac{86}{10.5} = 8.19 \Omega$$

$$X_{01} = \sqrt{(8.19^2 - 3.26^2)} = 7.51 \Omega$$

$$(e) \quad X_{02} = K^2 X_{01} = (220/2200)^2 \times 7.51 = 0.0751 \Omega$$

$$(f) \text{ We will use the definition of regulation as given in Art. 32.24 (3).}$$

We will find the rise in primary voltage necessary to maintain the output terminal voltage constant from no-load to full-load.

$$\text{Rated primary current} = 20,000/2200 = 9.1 \text{ A}$$

$$V_1 \approx \sqrt{[2200 \times 0.8 + 9.1 \times 3.26]^2 + (2200 \times 0.6 + 9.1 \times 7.51)^2} = 2265 \text{ V}$$

$$\therefore \% \text{ regn} = \frac{2265 - 2200}{2200} \times 100 = 2.95\%$$

We would get the same result by working in the secondary. Rated secondary current = 91 A.

$${}_0V_2 = \sqrt{(220 \times 0.8 + 91 \times 0.0326)^2 + (220 \times 0.6 + 91 \times 0.0751)^2} = 226.5 \text{ V}$$

$$\therefore \% \text{ regns.} = \frac{226.5 - 220}{220} \times 100 = 2.95\%$$

$$(g) \text{ Core loss} = 1.48 \text{ W. It will be the same for all loads.}$$

$$\text{Cu loss at full load} = I_1^2 R_{01} = 9.1^2 \times 3.26 = 270 \text{ W}$$

$$\text{Cu loss at half full-load} = 4.55^2 \times 3.26 = 67.5 \text{ W (or F.L. Cu loss/4)}$$

$$\therefore \eta \text{ at full-load} = \frac{22,000 \times 0.8 \times 100}{20,000 \times 0.8 + 148 + 270} = 97.4\%$$

$$\therefore \eta \text{ at half-load} = \frac{10,000 \times 0.8 \times 100}{10,000 \times 0.8 + 148 + 67.5} = 97.3\%$$

**Example 32.55.** Calculate the regulation of a transformer in which the ohmic loss is 1% of the output and the reactance drop is 5% of the voltage, when the power factor is (i) 0.80 Lag (ii) unity (iii) 0.80 Leading. (Madras University, 1997)

**Solution.** When 1% of output is the ohmic loss, p.u. resistance of the transformer,  $\epsilon_r = 0.01$

When 5% is the reactance drop, p.u. reactance of the transformer  $\epsilon_x = 0.05$

(i) Per Unit regulation of the transformer at full-load, 0.8 Lagging p.f.  
 $= 0.01 \times \cos \phi + 0.05 \times \sin \phi = 0.01 \times 0.8 + 0.05 \times 0.06 = 0.038$  or 3.8%

(ii) Per Unit regulation at unity p.f. =  $0.01 \times 1 = 0.01$  or 1%

(iii) Per Unit regulation at 0.8 Leading p.f. =  $0.01 \times 0.8 - 0.05 \times 0.6 = -0.022$  or -2.2%

**Example 32.56.** The maximum efficiency of a 500 kVA, 3300/500 V, 50 Hz, single phase transformer is 97% and occurs at 3/4<sup>th</sup> full-load u.p.f. If the impedance is 10% calculate the regulation at fullload, 0.8 p.f. Lag. (Madurai Kamraj University, November 1997)

**Solution.** At unity p.f. with 3/4<sup>th</sup> full load, the output of the transformer

$$= 500 \times 0.75 \times 1 \text{ kW} = 375 \text{ kW}$$

$$0.97 = \frac{375}{375 + 2 P_i}$$

where

$P_i$  = core loss in kW, at rated voltage.

$$\text{At maximum efficiency, } x^2 P_c = P_i$$

$$(0.75)^2 P_c = P_i$$

where  $x = 0.75$ , i.e. 3/4<sup>th</sup> which is the fractional loading of the transformer

$P_c$  = copper losses in kW, at rated current

$$P_i = \frac{1}{2} \left( (375) \times \left( \frac{1}{0.97} - 1 \right) \right) = \frac{1}{2} \times 375 \times \frac{3}{97} = 5.8 \text{ kW}$$

$$P_c = 5.8 / (0.75)^2 = 10.3 \text{ kW}$$

$$\text{Full load current in primary (H.V.) winding} = \frac{500 \times 1000}{3300} = \mathbf{151.5 \text{ amp}}$$

Total winding resistance ref. to primary

$$= \frac{10.3 \times 1000}{(151.5)^2} = 0.44876 \text{ ohm}$$

$$\epsilon_r = \% \text{ resistance} = \frac{151.5 \times 0.44876}{3300} \times 100 \% = \mathbf{2.06\%}$$

$$\epsilon_z = \% \text{ Impedance} = 10\%$$

$$\epsilon_x = \% \text{ reactance} = \sqrt{100 - 4.244} = \mathbf{9.7855\%}$$

By Approximate formula at 0.8 p.f. lag

$$\begin{aligned} \% \text{ regulation} &= \epsilon_r \cos \phi + \epsilon_x \sin \phi \\ &= 2.06 \times 0.8 + 9.7855 \times 0.6 \\ &= 1.648 + 5.87 = \mathbf{7.52 \%} \end{aligned}$$

**Example 32.57.** A transformer has copper-loss of 1.5% and reactance-drop of 3.5% when tested at full-load. Calculate its full-load regulation at (i) u.p.f. (ii) 0.8 p.f. Lagging and (iii) 0.8 p.f. Leading. (Bharathithasan Univ. April 1997)

**Solution.** The test-data at full-load gives following parameters :

$$\text{p.u. resistance} = 0.015, \quad \text{p.u. reactance} = 0.035$$

- (i) Approximate Voltage – Regulation at unity p.f. full load
- $$\begin{aligned} &= 0.015 \cos \phi + 0.035 \sin \phi \\ &= 0.015 \text{ per unit} = \mathbf{1.5\%} \end{aligned}$$
- (ii) Approximate Voltage – Regulation at 0.80 Lagging p.f.
- $$= (0.015 \times 0.8) + (0.035 \times 0.6) = 0.033 \text{ per unit} = \mathbf{3.3\%}$$
- (iii) Approximate Voltage Regulation at 0.8 leading p.f.
- $$\begin{aligned} &= I_r \cos \phi - I_x \sin \phi \\ &= (0.015 \times 0.8) - (0.035 \times 0.6) = -0.009 \text{ per unit} = \mathbf{-0.9\%} \end{aligned}$$

### Kapp Regulation Diagram

It has been shown that secondary terminal voltage falls as the load on the transformer is increased when p.f. is lagging and it increases when the power factor is leading. In other words, secondary terminal voltage not only depends on the load but on power factor also (Art. 32.16). For finding the voltage drop (or rise) which is further used in determining the regulation of the transformer, a graphical construction is employed which was proposed by late Dr. Kapp.

For drawing Kapp regulation diagram, it is necessary to know the equivalent resistance and reactance as referred to secondary i.e.  $R_{02}$  and  $X_{02}$ . If  $I_2$  is the secondary load current, then secondary terminal voltage on load  $V_2$ , is obtained by subtracting  $I_2 R_{02}$  and  $I_2 X_{02}$  voltage drops vectorially from secondary no-load voltage  ${}_0V_2$ .

Now,  ${}_0V_2$  is constant, hence it can be represented by a circle of constant radius  $OA$  as in Fig. 32.54. This circle is known as no-load or open-circuit e.m.f. circle. For a given load,  $OI_2$  represents the load current and is taken as the reference vector,  $CB$  represents  $I_2 R_{02}$  and is parallel to  $OI_2$ ,  $AB$  represents  $I_2 X_{02}$  and is drawn at right angles to  $CB$ . Vector  $OC$  obviously represents  $I_2 X_{02}$  and is drawn at right

angles to  $CB$ . Vector  $OC$  obviously represents secondary terminal voltage  $V_2$ . Since  $I_2$  is constant, the drop triangle  $ABC$  remains constant in size. It is seen that end point  $C$  of  $V_2$  lies on another circle whose centre is  $O'$ . This point  $O'$  lies at a distance of  $I_2 X_{02}$  vertically below the point  $O$  and a distance of  $I_2 R_{02}$  to its left as shown in Fig. 32.54.

Suppose it is required to find the voltage drop on full-load at a lagging power factor of  $\cos \phi$ , then a radius  $OLP$  is drawn inclined at an angle of  $\phi$  with  $OX$ .  $LM = I_2 R_{02}$  and is drawn horizontal  $MN = I_2 X_{02}$  and is drawn perpendicular to  $LM$ . Obviously,  $ON$  is no-load voltage  ${}_0V_2$ . Now,  $ON = OP = {}_0V_2$ . Similarly,  $OL$  is  $V_2$ . The voltage drop =  $OP - OL = LP$ .

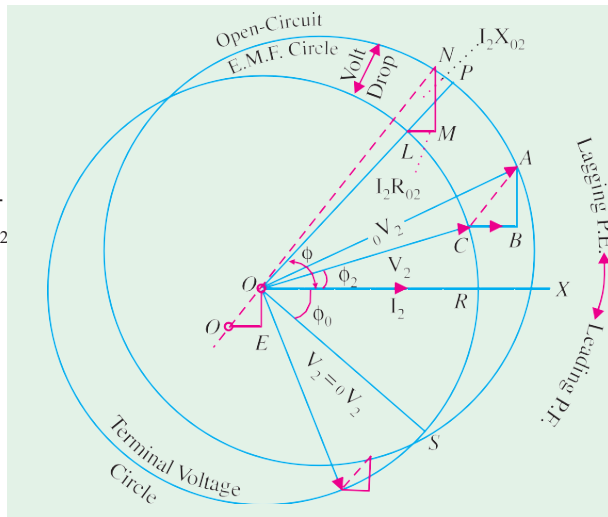

Fig. 32.54

$$\text{Hence, percentage regulation 'down' is } = \frac{OP - OL}{OP} \times 100 = \frac{LP}{OP} \times 100$$

It is seen that for finding voltage drop, triangle  $LMN$  need not be drawn, but simply the radius  $OLP$ .

The diagram shows clearly how the secondary terminal voltage falls as the angle of lag increases. Conversely, for a leading power factor, the fall in secondary terminal voltage decreases till for an angle of  $\phi_0$  leading, the fall becomes zero; hence  $V_2 = {}_0V_2$ . For angles greater than  $\phi_0$ , the secondary terminal voltage  $V_2$  becomes greater than  ${}_0V_2$ .

The Kapp diagram is very helpful in determining the variation of regulation with power factor but it has the disadvantage that since the lengths of the sides of the impedance triangle are very small as compared to the radii of the circles, the diagram has to be drawn on a very large scale, if sufficiently accurate results are desired.

### Sumpner of Back-to-Back Test

This test provides data for finding the regulation, efficiency and heating under load conditions and is employed only when two similar transformers are available. One transformer is loaded on the other and both are connected to supply. The power taken from the supply is that necessary for supplying the losses of both transformers and the negligibly small loss in the control circuit.

As shown in Fig. 32.55, primaries of the two transformers are connected in parallel across the same a.c. supply. With switch  $S$  open, the wattmeter  $W_1$  reads the core loss for the two transformers.

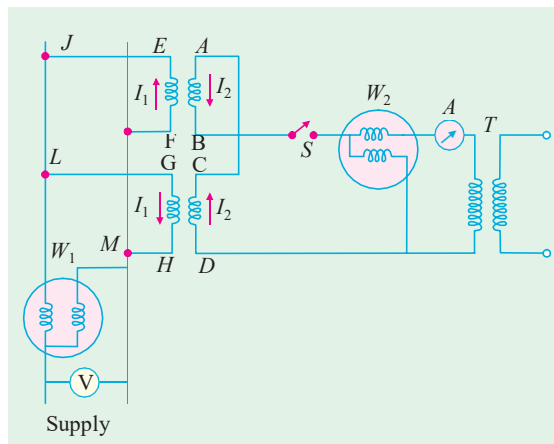

Fig. 32.55

The secondaries are so connected that their potentials are in opposition to each other. This would so if  $V_{AB} = V_{CD}$  and  $A$  is joined to  $C$  whilst  $B$  is joined to  $D$ . In that case, there would be no secondary current flowing around the loop formed by the two secondaries.  $T$  is an auxiliary low-voltage transformer which can be adjusted to give a variable voltage and hence current in the secondary loop circuit. By proper adjustment of  $T$ , full-load secondary current  $I_2$  can be made to flow as shown. It is seen, that  $I_2$  flows from  $D$  to  $C$  and then from  $A$  to  $B$ . Flow of  $I_1$  is confined to the loop  $FEJLGHMF$  and it does not pass through  $W_1$ . Hence,  $W_1$  continues to read the core loss and  $W_2$  measures full-load Cu loss (or at any other load current value  $I_2$ ). Obviously, the power taken in is twice the losses of a single transformer.

**Example 32.58.** Two similar 250-kVA, single-phase transformers gave the following results when tested by back-to-back method :

Mains wattmeter,  $W_1 = 5.0 \text{ kW}$

Primary series circuit wattmeter,  $W_2 = 7.5 \text{ kW}$  (at full-load current).

Find out the individual transformer efficiencies at 75% full-load and 0.8 p.f. lead.

(Electrical Machines-III, Gujarat Univ. 1986)

**Solution.** Total losses for both transformers =  $5 + 7.5 = 12.5 \text{ kW}$

F.L. loss for each transformer =  $12.5/2 = 6.25 \text{ kW}$

$$\text{Copper-loss at 75\% load} = \left(\frac{3}{4}\right)^2 \times \frac{7.5}{2} \text{ kW} = 2.11 \text{ kW}$$

Output of each transformer at 75% F.L. and 0.8 p.f. =  $(250 \times 0.75) \times 0.8 = 150 \text{ kW}$

$$\eta = \frac{150}{150 + 2.5 + 2.11} = 97\%$$

### Losses in a Transformer

In a static transformer, there are no friction or windage losses. Hence, the only losses occurring are:

**Core or Iron Loss :** It includes both hysteresis loss and eddy current loss. Because the core flux in a transformer remains practically constant for all loads (its variation being

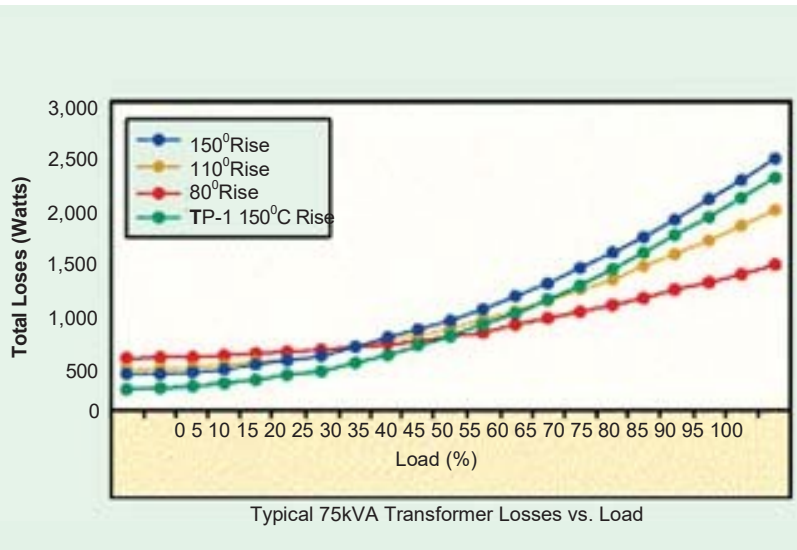

1 to 3% from no-load to full-load). The core loss is practically the same at all loads.

Hysteresis loss  $W_h = \eta B_{\max}^{1.6} f V$  watt; eddy current loss  $W_e = PB_{\max}^2 f^2 t^2$  watt

These losses are minimized by using steel of high silicon content for the core and by using very thin

laminations. Iron or core loss is found from the *O.C.* test. *The input of the transformer when on no-load measures the core loss.*

Ⓜ **Copper loss.** This loss is due to the ohmic resistance of the transformer windings. Total Cu loss  $= I_1^2 R_1 + I_2^2 R_2 = I_1^2 R_{01} + I_2^2 R_{02}$ . It is clear that Cu loss is proportional to (current)<sup>2</sup> or kVA<sup>2</sup>. In other words, Cu loss at half the full-load is one-fourth of that at full-load.

The value of Cu loss is found from the short-circuit test (Art. 32.22).

### Efficiency of a Transformer

As is the case with other types of electrical machines, the efficiency of a transformer at a particular load and power factor is defined as the output divided by the input—the two being measured in the same units (either watts or kilowatts).

$$\text{Efficiency} = \frac{\text{Output}}{\text{Input}}$$

But a transformer being a highly efficient piece of equipment, has very small loss, hence it is impractical to try to measure transformer efficiency by measuring input and output. These quantities are nearly of the same size. A better method is to determine the losses and then to calculate the efficiency from ;

$$\text{Efficiency} = \frac{\text{Output}}{\text{Output} + \text{losses}} = \frac{\text{Output}}{\text{Output} + \text{Cu loss} + \text{iron loss}}$$

or

$$\eta = \frac{\text{Input} - \text{Losses}}{\text{Input}} = 1 - \frac{\text{losses}}{\text{Input}}$$

It may be noted here that efficiency is based on power output in watts and not in volt-amperes, although losses are proportional to VA. Hence, at any volt-ampere load, the efficiency depends on power factor, being maximum at a power factor of unity.

Efficiency can be computed by determining core loss from no-load or open-circuit test and Cu loss from the short-circuit test.

### Condition for Maximum Efficiency

$$\text{Cu loss} = I_1^2 R_{01} \quad \text{or} \quad I_2^2 R_{02} = \frac{W_{cu}}{a}$$

$$\text{Iron loss} = \text{Hysteresis loss} + \text{Eddy current loss} = W_h + W_e = W_i$$

Considering primary side,

$$\begin{aligned} \text{Primary input} &= V_1 I_1 \cos \phi_1 \\ \eta &= \frac{V_1 I_1 \cos \phi_1 - \text{losses}}{V_1 I_1 \cos \phi_1} = \frac{V_1 I_1 \cos \phi_1 - I_1^2 R_{01} - W_i}{V_1 I_1 \cos \phi_1} \\ &= 1 - \frac{I_1 R_{01}}{V_1 \cos \phi_1} - \frac{W_i}{V_1 I_1 \cos \phi_1} \end{aligned}$$

Differentiating both sides with respect to  $I_1$ , we get

$$\frac{d\eta}{dI_1} = 0 - \frac{R_{01}}{V_1 \cos \phi_1} + \frac{W_i}{V_1 I_1^2 \cos \phi_1}$$

For  $\eta$  to be maximum,  $\frac{d\eta}{dI_1} = 0$ . Hence, the above equation becomes

$$\frac{R_{01}}{V_1 \cos \phi_1} = \frac{W_i}{V_1 I_1^2 \cos \phi_1} \quad \text{or} \quad W_i = I_1^2 R_{01} \quad \text{or} \quad I_2^2 R_{02}$$

or

$$\text{Cu loss} = \text{Iron loss}$$



The output current corresponding to maximum efficiency is  $I_2 = \sqrt{(W_i/R_{02})}$ .

It is this value of the output current which will make the Cu loss equal to the iron loss. By proper design, it is possible to make the maximum efficiency occur at any desired load.

**Note. (i)** If we are given iron loss and full-load Cu loss, then the load at which two losses would be equal (i.e. corresponding to maximum efficiency) is given by

$$= \text{Full load} \times \sqrt{\left(\frac{\text{Iron loss}}{\text{F.L. Cu loss}}\right)}$$

In Fig. 32.56, Cu losses are plotted as a percentage of power input and the efficiency curve as deduced from these is also shown. It is obvious that the point of intersection of the Cu and iron loss curves gives the point of maximum efficiency. It would be seen that the efficiency is high and is practically constant from 15% full-load to 25% overload.

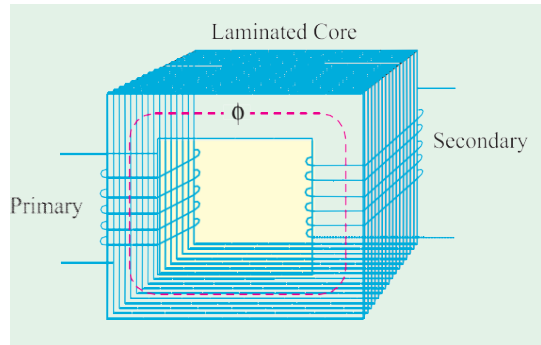

Fig. 32.56

**(ii)** The efficiency at any load is given by

$$\eta = \frac{x \times \text{full-load kVA} \times \text{p.f.}}{(x \times \text{full-load kVA} \times \text{p.f.}) + W_{cu} + W_i} \times 100$$

where  $x$  = ratio of actual to full-load kVA

$W_i$  = iron loss in kW ;  $W_{cu}$  = Cu loss in kW.

**Example 32.59.** In a 25-kVA, 2000/200 V, single-phase transformer, the iron and full-load copper losses are 350 and 400 W respectively. Calculate the efficiency at unity power factor on (i) full load (ii) half full-load. (Elect. Engg. & Electronic, Bangalore Univ. 1990 and Similar example in U.P. Technical University 2001)

**Solution. (i) Full-load Unity p.f.**

$$\text{Total loss} = 350 + 400 = 750 \text{ W}$$

$$\text{F.L. output at u.p.f.} = 25 \times 1 = 25 \text{ kW} ; \eta = 25/25.75 = 0.97 \text{ or } 97\%$$

**(ii) Half F.L. Unity p.f.**

Cu loss =  $400 \times (1/2)^2 = 100 \text{ W}$ . Iron loss remains constant at 350 W, Total loss =  $100 + 350 = 450 \text{ W}$ .

Half-load output at u.p.f. = 12.5 kW

$$\therefore \eta = 12.5/(12.5 + 0.45) = 96.52\%$$

**Example 32.60.** If  $P_1$  and  $P_2$  be the iron and copper losses of a transformer on full-load, find the ratio of  $P_1$  and  $P_2$  such that maximum efficiency occurs at 75% full-load. (Elect. Machines AMIE Sec. B, Summer 1992)

**Solution.** If  $P_2$  is the Cu loss at full-load, its value at 75% of full-load is  $= P_2 \times (0.75)^2 = 9P_2/16$ . At maximum efficiency, it equals the iron loss  $P_1$  which remains constant throughout. Hence, at maximum efficiency,

$$P_1 = 9P_2/16 \text{ or } P_1/P_2 = 9/16.$$

**Example 32.61.** A 11000/230 V, 150-kVA, 1-phase, 50-Hz transformer has core loss of 1.4 kW and F.L. Cu loss of 1.6 kW. Determine

(i) the kVA load for max. efficiency and value of max. efficiency at unity p.f.

(ii) the efficiency at half F.L. 0.8 p.f. leading (Basic Elect. Machine, Nagpur Univ. 1993)

**Solution. (i)** Load kVA corresponding to maximum efficiency is

$$= \text{F.L. kVA} \times \frac{\sqrt{\text{Iron loss}}}{\sqrt{\text{F.L. Cu loss}}} = 250 \times \frac{1.6}{\sqrt{1.4}} = 160 \text{ kVA}$$

Since Cu loss equals iron loss at maximum efficiency, total loss = 1.4 + 1.4 = 2.8 kW ;  
output = 160 × 1 = 160 kW

$$\eta_{max} = 160/162.8 = 0.982 \text{ or } 98.2\%$$

**(ii)** Cu loss at half full-load =  $1.6 \times (1/2)^2 = 0.4 \text{ kW}$  ; Total loss = 1.4 + 0.4 = 1.8 kW  
Half F.L. output at 0.8 p.f. =  $(150/2) \times 0.8 = 60 \text{ kW}$

$$\therefore \text{Efficiency} = 60/(60 + 1.8) = 0.97 \text{ or } 97\%$$

**Example 32.62.** A 5-kVA, 2,300/230-V, 50-Hz transformer was tested for the iron losses with normal excitation and Cu losses at full-load and these were found to be 40 W and 112 W respectively. Calculate the efficiencies of the transformer at 0.8 power factor for the following kVA outputs :

1.25                  2.5                  3.75                  5.0                  6.25                  7.5

Plot efficiency vs kVA output curve.

(Elect. Engg. -I, Bombay Univ. 1987)

**Solution.** F.L. Cu loss = 112 W ; Iron loss = 40 W

**(i)** Cu loss at 1.25 kVA =  $112 \times (1.25/5)^2 = 7 \text{ W}$   
Total loss = 40 + 7 = 47 W    Output = 1.25 × 0.8 = 1 kW = 1,000 W  
 $\eta = 100 \times 1,000/1,047 = 95.51 \%$

**(ii)** Cu loss at 2.5 kVA =  $112 \times (2.5/5)^2 = 28 \text{ W}$   
Total loss = 40 + 28 = 68 W  
Output = 2.5 × 0.8 = 2 kW

$$\eta = 2,000 \times 100/2,068 = 96.71\%$$

**(iii)** Cu loss at 3.75 kVA

$$= 112 \times (3.75/5)^2 = 63 \text{ W}$$

$$\text{Total loss} = 40 + 63 = 103 \text{ W}$$

$$\eta = 3,000 \times 100/3,103 = 96.68 \%$$

**(iv)** Cu loss at 5 kVA

$$= 112 \text{ W}$$

$$\text{Total loss} = 152 \text{ W} = 0.152 \text{ kW}$$

$$\text{Output} = 5 \times 0.8 = 4 \text{ kW}$$

$$\eta = 4 \times 100/4.142 = 96.34 \%$$

**(v)** Cu loss at 6.25 kVA

$$= 112 \times (6.25/5)^2 = 175 \text{ W}$$

$$\text{Total loss} = 125 \text{ W} = 0.125 \text{ kW} ; \text{Output} = 6.25 \times 0.8 = 5 \text{ kW}$$

$$\eta = 5 \times 100/5.215 = 95.88 \%$$

**(vi)** Cu loss at 7.5 kVA =  $112 \times (7.5/5)^2 = 252 \text{ W}$

$$\text{Total loss} = 292 \text{ W} = 0.292 \text{ kW} ; \text{Output} = 7.5 \times 0.8 = 6 \text{ kW}$$

$$\eta = 6 \times 100/6.292 = 95.36 \%$$

The curve is shown in Fig. 32.57.

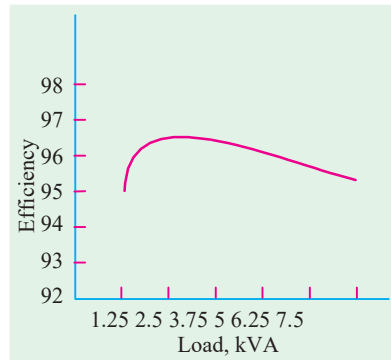

Fig. 32.57

**Example 32.63.** A 200-kVA transformer has an efficiency of 98% at full load. If the max. efficiency occurs at three quarters of full-load, calculate the efficiency at half load. Assume negligible magnetizing current and p.f. 0.8 at all loads. (Elect. Technology Punjab Univ. Jan. 1991)

**Solution.** As given, the transformer has a F.L. efficiency of 98 % at 0.8 p.f.

$$\text{F.L. output} = 200 \times 0.8 = 160 \text{ kW} ; \text{F.L. input} = 160/0.98 = 163.265 \text{ kW}$$

$$\text{F.L. losses} = 163.265 - 160 = 3.265 \text{ kW}$$

This loss consists of F.L. Cu loss  $x$  and iron loss  $y$ .

$$\therefore x + y = 3.265 \text{ kW} \quad \dots(i)$$

It is also given that  $\eta_{max}$  occurs at three quarters of full-load when Cu loss becomes equal to iron loss.

$$\therefore \text{Cu loss at 75 \% of F.L.} = x (3/4)^2 = 9x/16$$

$$\text{Since } y \text{ remains constant, hence } 9x/16 = y \quad \dots(ii)$$

Substituting the value of  $y$  in Eqn. (i), we get  $x + 9x/16 = 3265$  or  $x = 2090 \text{ W}$ ;  $y = 1175 \text{ W}$

**Half-load Unity p.f.**

$$\text{Cu loss} = 2090 \times (1/2)^2 = 522 \text{ W} ; \text{total loss} = 522 + 1175 = 1697 \text{ W}$$

$$\text{Output} = 100 \times 0.8 = 80 \text{ kW} ; \eta = 80/81.697 = 0.979 \text{ or } \mathbf{97.9 \%}$$

**Example 32.64.** A 25-kVA, 1-phase transformer, 2,200 volts to 220 volts, has a primary resistance of  $1.0 \Omega$  and a secondary resistance of  $0.01 \Omega$ . Find the equivalent secondary resistance and the full-load efficiency at 0.8 p.f. if the iron loss of the transformer is 80% of the full-load Cu loss.

(Elect. Technology, Utkal Univ. 1998)

**Solution.**  $K = 220/2,200 = 1/10$ ;  $R_{02} = R_2 + K^2 R_1 = 0.01 + 1/100 = \mathbf{0.02 \Omega}$

$$\text{Full-load } I_2 = 25,000/220 = 113.6 \text{ A} ; \text{F.L. Cu loss} = I_2^2 R_{02} = 113.6^2 \times 0.02 = 258 \text{ W.}$$

$$\text{Iron loss} = 80\% \text{ of } 258 = 206.4 \text{ W} ; \text{Total loss} = 258 + 206.4 = 464.4 \text{ W}$$

$$\text{F.L. output} = 25 \times 0.8 = 20 \text{ kW} = 20,000 \text{ W}$$

$$\text{Full-load } \eta = 20,000 \times 100 / (20,000 + 464.4) = \mathbf{97.7 \%}$$

**Example 32.65.** A 4-kVA, 200/400-V, 1-phase transformer has equivalent resistance and reactance referred to low-voltage side equal to  $0.5 \Omega$  and  $1.5 \Omega$  respectively. Find the terminal voltage on the high-voltage side when it supplies 3/4th full-load at power factor of 0.8, the supply voltage being 220 V. Hence, find the output of the transformer and its efficiency if the core losses are 100 W.

(Electrical Engineering ; Bombay Univ. 1985)

**Solution.** Obviously, primary is the low-voltage side and the secondary, the high voltage side.

Here,  $R_{01} = 0.5 \Omega$  and  $X_{01} = 1.5 \Omega$ . These can be transferred to the secondary side with the help of the transformation ratio.

$$K = 400/200 = 2 ; R_{02} = K^2 R_{01} = 2^2 \times 0.5 = 2 \Omega ; X_{02} = K^2 X_{01} = 4 \times 1.5 = 6 \Omega$$

$$\text{Secondary current when load is } 3/4 \text{ the, full-load is } = (1,000 \times 4 \times 3/4) / 400 = 7.5 \text{ A}$$

Total drop as referred to transformer secondary is

$$= I_2 (R_{02} \cos \phi + X_{02} \sin \phi)^* = 7.5 (2 \times 0.8 + 6 \times 0.6) = 39 \text{ V}$$

$\therefore$  Terminal voltage on high-voltage side under given load condition is

$$= 400 - 39 = \mathbf{361 \text{ V}}$$

$$\text{Cu loss} = I_2^2 R_{02} = 7.5^2 \times 2 = 112.5 \text{ W}$$

$$\text{Iron loss} = 100 \text{ W}$$

$$\text{Total loss} = 212.5 \text{ W}$$

$$\text{output} = (4 \times 3/4) \times 0.8 = \mathbf{2.4 \text{ kW}}$$

$$\text{Input} = 2,400 + 212.5 = 2,612.5 \text{ W}$$

$$\eta = 2,400 \times 100 / 2,612.5 = \mathbf{91.87 \%}$$

**Example 32.66.** A 20-kVA, 440/220 V, I- $\phi$ , 50 Hz transformer has iron loss of 324 W. The Cu loss is found to be 100 W when delivering half full-load current. Determine (i) efficiency when

\* Assuming a lagging power factor

delivering full-load current at 0.8 lagging p.f. and (ii) the percent of full-load when the efficiency will be maximum. **(Electrotechnique-II, M.S. Univ., Baroda 1987)**

**Solution.** F.L. Cu loss =  $2^2 \times 100 = 400$  W ; Iron loss = 324 W

$$(i) \quad \text{F.L. efficiency at 0.8 p.f.} = \frac{20 \times 0.8}{(20 \times 0.8) + 0.724} \times 100 = \mathbf{95.67\%}$$

$$(ii) \quad \frac{\text{kVA for maximum}}{\text{F.L. kVA}} = \frac{\sqrt{\text{Iron loss}}}{\sqrt{\text{F.L. Cu loss}}} = \frac{\sqrt{324}}{\sqrt{400}} = 0.9$$

Hence, efficiency would be maximum at **90%** of F.L.

**Example 32.67.** Consider a 4-kVA, 200/400 V single-phase transformer supplying full-load current at 0.8 lagging power factor. The O.C./S.C. test results are as follows :

O.C. test : 200 V, 0.8 A, 70 W (I.V. side)

S.C. test : 20 V, 10 A, 60 (H.V. side)

Calculate efficiency, secondary voltage and current into primary at the above load.

Calculate the load at unity power factor corresponding to maximum efficiency.

**(Elect. Machines Nagpur Univ. 1993)**

**Solution.** Full-load,  $I_2 = 4000/400 = 10$  A

It means that S.C. test has been carried out with full secondary flowing. Hence, 60 W represents full-load Cu loss of the transformer.

Total F.L. losses =  $60 + 70 = 130$  W ; F.L. output =  $4 \times 0.8 = 3.2$  kW

F.L.  $\eta = 3.2/3.33 = 0.96$  or **96%**

**S.C. Test**

$$\mathbf{Z}_{02} = 20/10 = 2 \Omega ; \frac{1}{2} R_{02} = 60 \text{ or } R_{02} = 60/10^2 = 0.6 \Omega ; X_{02} = \sqrt{2^2 - 0.6^2} = 1.9 \Omega$$

Transformer voltage drop as referred to secondary

$$= I_2 (R_{02} \cos \phi + X_{02} \sin \phi) = 10 (0.6 \times 0.8 + 1.9 \times 0.6) = 16.2 \text{ V}$$

$$\therefore V_2 = 400 - 16.2 = 383.8 \text{ V}$$

Primary current =  $4000/200 = 20$  A

kVA corresponding to  $\eta_{max} = 4 \times \sqrt{70/60} = 4.32$  kVA

$\therefore$  Load at u.p.f. corresponding to  $\eta_{max} = 4.32 \times 1 = \mathbf{4.32}$  kW

**Example 32.68.** A 600 kVA, 1-phase transformer has an efficiency of 92% both at full-load and half-load at unity power factor. Determine its efficiency at 60% of full-load at 0.8 power factor lag.

**(Elect. Machines, A.M.I.E. Sec. B, 1992)**

**Solution.**

$$\eta = \frac{x \times kVA \times \cos \phi}{(x \times kVA) \times \cos \phi + W_i + x^2 W_{Cu}} \times 100$$

where  $x$  represents percentage of full-load

$W_i$  is iron loss and  $W_{Cu}$  is full-load Cu loss.

**At F.L. u.p.f.** Here  $x = 1$

$$\therefore 92 = \frac{1 \times 600 \times 1}{1 \times 600 \times 1 + W_i + W_{Cu}} \times 100, W_i + W_{Cu} = 52.174 \text{ kW} \quad \dots(i)$$

At half F.L. UPF. Here  $x = 1/2$

$$92 = \frac{1/2 \times 600 \times 1}{(1/2) \times 600 \times 1 + W_i + (1/2)^2 W_{Cu}} \times 100;$$

$$\therefore W_i + 0.25 W_{Cu} = 26.087 \text{ kW} \quad \dots(ii)$$

From (i) and (ii), we get,  $W_i = 17.39 \text{ kW}$ ,  $W_{Cu} = 34.78 \text{ kW}$

**60 % F.L. 0.8 p.f. (lag)** Here,  $x = 0.6$

$$\eta = \frac{0.6 \times 600 \times 0.8 \times 100}{(0.6 \times 600 \times 0.8) + 17.39 + (0.6)^2 34.78} = \mathbf{85.9 \%}$$

**Example 32.69.** A 600-kVA, 1-ph transformer when working at u.p.f. has an efficiency of 92 % at full-load and also at half-load. Determine its efficiency when it operates at unity p.f. and 60 % of full-load. **(Electric. Machines, Kerala Univ. 1987)**

**Solution.** The fact that efficiency is the same i.e. 92 % at both full-load and half-load will help us to find the iron and copper losses.

**At full-load**

Output = 600 kW ; Input = 600/0.92 = 652.2 kW ; Total loss = 652.2 – 600 = 52.2 kW

Let  $x$  = Iron loss – It remains constant at all loads.

$y$  = F.L. Cu loss – It is  $\propto (\text{kVA})^2$ .  $\therefore x + y = 52.2 \quad \dots(i)$

**At half-load**

Output = 300 kW ; Input = 300/0.92  $\therefore$  Losses = (300/0.92 – 300) = 26.1 kW

Since Cu loss becomes one-fourth of its F.L. value, hence

$$x + y/4 = 26.1$$

Solving for  $x$  and  $y$ , we get  $x = \mathbf{17.4 \text{ kW}}$  ;  $y = 34.8 \text{ kW} \quad \dots(ii)$

**At 60 % full-load**

Cu loss = 0.62  $\times$  34.8 = 12.53 kW ; Total loss = 17.4 + 12.53 = 29.93 kW

Output = 600  $\times$  0.6 = 360 kW  $\therefore \eta = 360/389.93 = 0.965$  or **96.5 %**

**Example 32.70.** The maximum efficiency of a 100-kVA, single phase transformer is 98% and occurs at 80% of full load at 8 p.f. If the leakage impedance of the transformer is 5 %, find the voltage regulation at rated load of 0.8 power factor lagging. **(Elect. Machines-I, Nagpur Univ. 1993)**

**Solution.** Since maximum efficiency occurs at 80 percent of full-load at 0.8 p.f.,

Output at  $\eta_{max} = (100 \times 0.8) \times 0.8 = 64 \text{ kW}$  ; Input = 64/0.98 = 65.3 kW

$\therefore$  Total loss = 65.3 – 64 = 1.3 kW. This loss is divided equally between Cu and iron.

$\therefore$  Cu loss at 80 % of full-load = 1.3/2 = 0.65 kW

Cu loss at full-load = 0.65/0.8<sup>2</sup> = 1 kW

$$\% R = \frac{\text{Cu loss}}{V_2 I_2} \times 100 = 1 \times \frac{100}{100} = 1 \% = v_r ; v_x = 5 \%$$

$$\therefore \% \text{ age regn.} = (1 \times 0.8 + 5 \times 0.6) + \frac{1}{200} (5 \times 0.8 - 1 \times 0.6)^2 = \mathbf{0.166 \%}$$

**Example 32.71.** A 10 kVA, 5000/440-V, 25-Hz single phase transformer has copper, eddy current and hysteresis losses of 1.5, 0.5 and 0.6 per cent of output on full load. What will be the percentage losses if the transformer is used on a 10-kV, 50-Hz system keeping the full-load current constant ? Assume unity power factor operation. Compare the full load efficiencies for the two cases. **(Elect. Machines, A.M.I.E., Sec. B, 1991)**

**Solution.** We know that  $E_1 = 4.44 f N_1 B_1 A$  .. When both excitation voltage and frequency are doubled, flux remains unchanged.

F.L. output at upf = 10 kVA  $\times$  1 = 10 kW

F.L. Cu loss =  $1.5 \times 10/100 = 0.15$  kW ; Eddy current loss

=  $0.5 \times 10/100 = 0.05$  kW ; Hysteresis loss =  $0.6 \times 10/100 = 0.06$  kW

Now, full-load current is kept constant but voltage is increased from 5000 V to 10,000 V. Hence, output will be doubled to 20 kW. Due to constant current, Cu loss would also remain constant.

New Cu loss = 0.15 kW, % Cu loss =  $(0.15/20) \times 100 = 0.75$  %

Now, eddy current loss  $\propto f^2$  and hysteresis loss  $\propto f$ .

New eddy current loss =  $0.05 (50/25)^2 = 0.2$  kW, % eddy current loss =  $(0.2/20) \times 100 = 1$  %

Now,  $W_h = 0.06 \times (50/25) = 0.12$  kW, %  $W_h = (0.12/20) \times 100 = 0.6$  %

$$\eta_1 = \frac{10}{10 + 0.15 + 0.05 + 0.06} \times 100 = 87.4\%$$

$$\eta_2 = \frac{20}{20 + 0.15 + 0.2 + 0.12} \times 100 = 97.7\%$$

**Example 32.72.** A 300-kVA, single-phase transformer is designed to have a resistance of 1.5 % and maximum efficiency occurs at a load of 173.2 kVA. Find its efficiency when supplying full-load at 0.8 p.f. lagging at normal voltage and frequency. (Electrical Machines-I, Gujarat Univ. 1985)

**Solution.** %  $R = \frac{\text{F.L. Cu loss}}{\text{Full-load } V_2 I_2} \times 100$  ;  $1.5 = \frac{\text{F.L. Cu loss}}{300 \times 1000} \times 100$

$\therefore$  F.L. Cu loss =  $1.5 \times 300 \times 1000/100 = 4500$  W

Also,  $173.2 = 300 \sqrt{\frac{\text{Iron Loss}}{4500}}$  ; Iron loss = 1500 W

Total F.L. loss = 4500 + 1500 = 6 kW

$$\text{F.L. } \eta \text{ at 0.8 p.f.} = \frac{300 \times 0.8}{(300 \times 0.8) + 6} \times 100 = 97.6\%$$

**Example 32.73.** A single phase transformer is rated at 100-kVA, 2300/230-V, 50 Hz. The maximum flux density in the core is 1.2 Wb/m<sup>2</sup> and the net cross-sectional area of the core is 0.04 m<sup>2</sup>. Determine

(a) The number of primary and secondary turns needed.

(b) If the mean length of the magnetic circuit is 2.5 m and the relative permeability is 1200, determine the magnetising current. Neglect the current drawn for the core loss.

(c) On short-circuit with full-load current flowing, the power input is 1200 W and an open-circuit with rated voltage, the power input was 400 W. Determine the efficiency of the transformer at 75 % of full-load with 0.8 p.f. lag.

(d) If the same transformer is connected to a supply of similar voltage but double the frequency (i.e., 100 Hz). What is the effect on its efficiency? (Elect. Engg., Bombay Univ. 1988)

**Solution.** (a) Applying e.m.f. equation of the transformer to the primary, we have

$$2300 = 4.44 \times 50 \times N_1 \times (1.2 \times 0.04) \quad \therefore N_1 = 216$$

$$K = 230/2300 = 1/10 \quad N_2 = KN_1 = 216/10 = 21.6 \text{ or } 22$$

$$(b) \quad AT = H \times l = \frac{B}{\mu_0 \mu_r} \times l = \frac{1.2 \times 2.5}{4\pi \times 10^{-7} \times 1200} = 1989 \quad \therefore I = \frac{1989}{216} = 9.21 \text{ A}$$

(c) F.L. Cu loss = 1200 W – S.C. test ; Iron loss = 400 W – O.C. test

Cu loss at 75 % of F.L. =  $(0.75)^2 \times 1200 = 675$  W

Total loss = 400 + 675 = 1075 kW

Output =  $100 \times (3/4) \times 0.8 = 60$  kW ;  $\eta = (60/61.075) \times 100 = 98.26\%$

- (d) When frequency is doubled, iron loss is increased because  
 (i) hysteresis loss is doubled –  $W_h \propto f$   
 (ii) eddy current loss is quadrupled –  $W_e \propto f^2$   
 Hence, efficiency will be decreased.

**Example 32.74.** A transformer has a resistance of 1.8 % and a reactance of 5.4 %. (a) At full load, what is the power-factor at which the regulation will be : (i) Zero, (ii) positive-maximum ?  
 (b) If its maximum efficiency occurs at full-load (at unity p.f.), what will be the efficiency under these conditions ?

**Solution :** Approximate percentage regulation is given, in this case, by the relationship  
 $1.8 \cos \phi \pm 5.4 \sin \phi$ .

(a) **Regulation :**

- (i) If regulation is zero, negative sign must be applicable. This happens at leading p.f.

$$\text{Corresponding p.f.} = \tan \phi = 1.8/5.4 = 0.333 \text{ leading}$$

$$\phi = 18.44^\circ \text{ leading}$$

- (ii) For maximum positive regulation, lagging p.f. is a must. From phasor diagram, the result can be obtained.

$$\text{Corresponding } \tan \phi = 5.4/1.8 = 3, \phi = 71.56^\circ \text{ lagging}$$

$$\% \text{ Voltage regulation} = 1.8 \cos \phi + 5.4 \sin \phi = 5.7\%$$

(b) **Efficiency :** Maximum efficiency occurs at such a load when

$$\text{Iron losses} = \text{Copper losses}$$

This means Iron-losses are 1.8 %.

$$\text{Efficiency} = 100/(100 + 1.8 + 1.8) = 96.52\%$$

**Example 32.75.** A 10 kVA, 1 phase, 50 Hz, 500/250 V transformer gave following test results :

OC test (LV) side : 250 V, 3.0 A, 200 W

SC test (LV) side : 15 V, 30 A, 300 W.

Calculate efficiency and regulation at full load, 0.8 p.f. lagging.

(Nagpur University, Summer 2000)

**Solution.** For efficiency calculations, full load current should be calculated, on the L.V. side in this case,

$$\text{F.L. Current} = \frac{10,000}{250} = 40 \text{ amp}$$

Short-circuit test data have been given at 30 A current on the L.V. side.

$$i^2 r \text{ losses at 40 A L.V. side} = \left(\frac{40}{30}\right)^2 \times 300 \text{ Watts} = 533.3 \text{ Watts}$$

At rated voltage, iron losses (from O.C. test) = 200 Watts

F.L. Output at 0.8 P.F. = 10,000 × 0.8 = 8000 Watts

$$\text{Hence, } \eta = \frac{8000}{8000 + 4733.3} \times 100\% = 91.6\%$$

For regulation, series resistance and reactance parameters of the equivalent circuit have to be evaluated, from the S.C. test.

$$\text{Series Impedance, } Z = \frac{15}{30} = 0.5 \text{ ohm}$$

$$\text{Series resistance, } r = \frac{300}{30 \times 30} = 0.333 \text{ ohm}$$

Series reactance,  $x = \sqrt{0.5^2 - 0.333^2} = 0.373 \text{ ohm}$

By Approximate formula,

p.u. regulation at full load, 0.8 p.f. lagging

$$= \frac{40}{250} [0.333 \times 0.8 - 0.373 \times 0.6] = 6.82 \times 10^{-3} \text{ p.u.}$$

When converted into volts, this is  $6.82 \times 10^{-3} \times 250 = 1.70 \text{ volt}$

**Example 32.76.** A 40 kVA, 1-ph, transformer has an iron loss of 400 W, and full copper loss of 800 W. Find the load at which maximum efficiency is achieved at unity power factor.

(Amravati University, Winter 1999)

**Solution.** If  $x$  = fraction of rated load at which the efficiency is maximum.

$$P_i = \text{Iron-loss} = 400 \text{ W}$$

$$P_c = \text{F.L. copper-loss} = 800 \text{ W}$$

Then

$$x^2 P_c = P_i$$

On substitution of numerical values of  $P_i$  and  $P_c$ , we get

$$x = 0.707$$

Hence, the efficiency is maximum, at unity p.f. and at 70.7 % of the rated Load. At this load, copper-loss = Iron-loss = 0.40 kW

$$\text{Corresponding output} = 40 \times 0.707 \times 1$$

$$= 28.28 \text{ kW}$$

$$\text{Corresponding efficiency} = \frac{28.28}{28.28 + 0.4 + 0.4} = 97.25 \%$$

**Extension to Question : (a)** At what load (s) at unity p.f. the efficiency will be 96.8 % ?

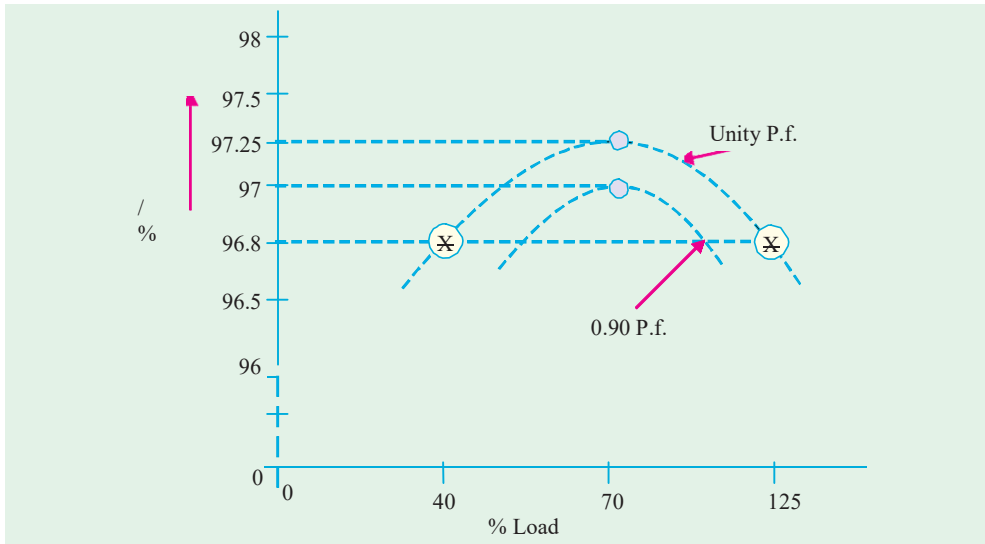

Fig. 32.58. Efficiency variation with load

**Solution.** Let  $x$  = Fractional load at which the concerned efficiency occurs, at unity p.f.

$$\frac{40x}{40x + 0.8x^2 + 0.40} = 0.968$$

This gives the following values of  $x$  :  $x_1 = 1.25$   $x_2 = 0.40$



Thus, at 40 % and at 125 % of the rated load, the efficiency will be **96.8%** as marked on the graph, in Fig.32.58.

**(b) How will maximum-efficiency condition be affected if the power factor is 0.90 lagging ?**

**Solution.**

The condition for efficiency-variation-statement is that the power factor remains constant. Thus, for 0.90 lagging p.f., another curve (Lower curve in Fig. 32.58) will be drawn for which the maximum efficiency will occur at the same value of  $x (= 0.707)$ , but

$$\begin{aligned} \text{Maximum efficiency} &= \frac{40 x \cos \phi}{40 \cos \phi + 0.80 x^2 + 0.40} \\ &= \frac{28.28 \times 0.90}{(28.28 \times 0.90) + 0.80} = \mathbf{97 \%} \end{aligned}$$

**Example 32.77.** A 10 kVA, 500/250 V, single-phase transformer gave the following test results:  
S.C. Test (H.V. side) : 60 V, 20 A, 150 W

The maximum efficiency occurs at unity power factor and at 1.20 times full-load current. Determine full-load efficiency at 0.80 p.f. Also calculate the maximum efficiency.

**(Rajiv Gandhi Technical University, Bhopal, Summer 2001)**

**Solution.** Full-load current on H.V. side =  $10,000/500 = 20$  Amp

S.C. test has been conducted from H.V. side only. Hence, full-load copper-loss, at unity p.f. = 150 watts

**(a)** Maximum efficiency occurs at 1.2 times full-load current, at unity p.f. corresponding copper-loss =  $(1.2)^2 \times 150 = 216$  watts

At maximum efficiency, copper-loss = core-loss = 216 watts

Corresponding Power-output =  $1.2 \times 10,000 \times 1.0 = 12$  kW

Hence, maximum efficiency at unity P.f. =  $(12)/(12 + 0.216 + 0.2160) = 0.9653 = 96.53 \%$

**(b)** Full-load efficiency at 0.80 P.f.

Output Power at full-load, 0.80 P.f. =  $10,000 \times 0.8 = 8000$  W, constant core-loss = 216 W

Corresponding copper-loss = 150 W

Total losses = 366 W

Hence, efficiency =  $(8000/8366) \times 100 \% = 95.63 \%$ .

### Variation of Efficiency with Power Factor

The efficiency of a transformer is given by

$$\begin{aligned} \eta &= \frac{\text{Output}}{\text{Input}} = \frac{\text{Input} - \text{Losses}}{\text{Input}} \\ &= 1 - \frac{\text{Losses}}{\text{Input}} = 1 - \frac{\text{Losses}}{(V_2 I_2 \cos \phi + \text{losses})} \end{aligned}$$

Let, losses/ $V_2 I_2 = x$

$$\begin{aligned} \therefore \eta &= 1 - \frac{\text{losses} / V_2 I_2}{\cos \phi + (\text{losses} / V_2 I_2)} \\ &= 1 - \frac{x}{(\cos \phi + x)} = 1 - \frac{x / \cos \phi}{1 + (x / \cos \phi)} \end{aligned}$$

The variations of efficiency with power factor at different loadings on a typical transformer are shown in Fig. 32.59.

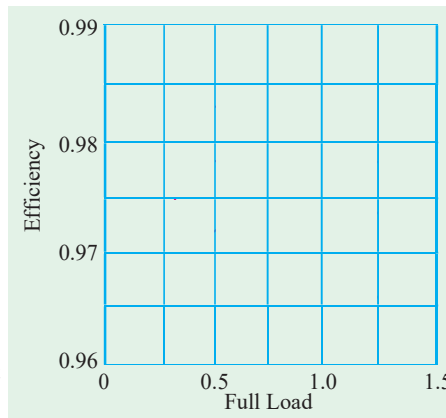

Fig. 32.59

## Tutorial Problems 32.4

1. A 200-kVA transformer has an efficiency of 98 % at full-load. If the maximum efficiency occurs at three-quarters of full-load, calculate (a) iron loss at F.L. (b) Cu loss at F.L. (c) efficiency at half-load. Ignore magnetising current and assume a p.f. of 0.8 at all loads.  
 [(a) 1.777 kW (b) 2.09 kW (c) 97.92%]
2. A 600 kVA, 1-ph transformer has an efficiency of 92 % both at full-load and half-load at unity power factor. Determine its efficiency at 60 % of full load at 0.8 power factor lag.  
 [90.59%] (*Elect. Machines, A.M.I.E. Sec. B, 1992*)
3. Find the efficiency of a 150 kVA transformer at 25 % full load at 0.8 p.f. lag if the copper loss at full load is 1600 W and the iron loss is 1400 W. Ignore the effects of temperature rise and magnetising current.  
 [96.15%] (*Elect. Machines, A.M.I.E. Sec. B, 1991*)
4. The F.L. Cu loss and iron loss of a transformer are 920 W and 430 W respectively. (i) Calculate the loading of the transformer at which efficiency is maximum (ii) what would be the losses for giving maximum efficiency at 0.85 of full-load if total full-load losses are to remain unchanged ?  
 [(i) 68.4% of F.L. (ii)  $W_i = 565 \text{ W}$  ;  $W_{cu} = 785 \text{ W}$ ]
5. At full-load, the Cu and iron losses in a 100-kVA transformer are each equal to 2.5 kW. Find the efficiency at a load of 65 kVA, power factor 0.8.  
 [93.58%] (*City & Guilds London*)
6. A transformer, when tested on full-load, is found to have Cu loss 1.8% and reactance drop 3.8%. Calculate its full-load regulation (i) at unity p.f. (ii) 0.8 p.f. lagging (iii) 0.8 p.f. leading.  
 [(i) 1.80% (ii) 3.7 % (iii) -0.88%]
7. With the help of a vector diagram, explain the significance of the following quantities in the open-circuit and short-circuit tests of a transformer (a) power consumed (b) input voltage (c) input current. When a 100-kVA single-phase transformer was tested in this way, the following data were obtained : On open circuit, the power consumed was 1300 W and on short-circuit the power consumed was 1200 W. Calculate the efficiency of the transformer on (a) full-load (b) half-load when working at unity power factor.  
 [(a) 97.6% (b) 96.9%] (*London Univ.*)
8. An 11,000/230-V, 150-kVA, 50-Hz, 1-phase transformer has a core loss of 1.4 kW and full-load Cu loss of 1.6 kW. Determine (a) the kVA load for maximum efficiency and the minimum efficiency (b) the efficiency at half full-load at 0.8 power factor lagging.  
 [140.33 kVA, 97.6% ; 97%]
9. A single-phase transformer, working at unity power factor has an efficiency of 90 % at both half-load and a full-load of 500 kW. Determine the efficiency at 75 % of full-load. [90.5%] (*I.E.E. London*)
10. A 10-kVA, 500/250-V, single-phase transformer has its maximum efficiency of 94 % when delivering 90 % of its rated output at unity power factor. Estimate its efficiency when delivering its full-load output at p.f. of 0.8 lagging.  
 [92.6%] (*Elect. Machinery, Mysore Univ, 1979*)
11. A single-phase transformer has a voltage ratio on open-circuit of 3300/660-V. The primary and secondary resistances are  $0.8 \Omega$  and  $0.03 \Omega$  respectively, the corresponding leakage reactance being  $4 \Omega$  and  $0.12 \Omega$ . The load is equivalent to a coil of resistance  $4.8 \Omega$  and inductive reactance  $3.6 \Omega$ . Determine the terminal voltage of the transformer and the output in kW.  
 [636 V, 54 kW]
12. A 100-kVA, single-phase transformer has an iron loss of 600 W and a copper loss of 1.5 kW at full-load current. Calculate the efficiency at (a) 100 kVA output at 0.8 p.f. lagging (b) 50 kVA output at unity power factor.  
 [(a) 97.44% (b) 98.09%]
13. A 10-kVA, 440/3300-V, 1-phase transformer, when tested on open circuit, gave the following figures on the primary side : 440V ; 1.3 A ; 115 W.  
 When tested on short-circuit with full-load current flowing, the power input was 140 W. Calculate the efficiency of the transformer at (a) full-load unity p.f. (b) one quarter full-load 0.8 p.f.  
 [(a) 97.51% (b) 94.18%] (*Elect. Engg-I, Sd. Patel Univ. June 1977*)
14. A 150-kVA single-phase transformer has a core loss of 1.5 kW and a full-load Cu loss of 2 kW. Calculate the efficiency of the transformer (a) at full-load, 0.8 p.f. lagging (b) at one-half full-load

unity p.f. Determine also the secondary current at which the efficiency is maximum if the secondary voltage is maintained at its rated value of 240 V. [(a) 97.17% (b) 97.4% ; 541 A]

15. A 200-kVA, 1-phase, 3300/400-V transformer gave the following results in the short-circuit test. With 200 V applied to the primary and the secondary short-circuited, the primary current was the full-load value and the input power 1650 W. Calculate the secondary p.d. and percentage regulation when the secondary load is passing 300 A at 0.707 p.f. lagging with normal primary voltage.

[380 V ; 480%]

16. The primary and secondary windings of a 40-kVA, 6600/250-V, single-phase transformer have resistances of  $10\ \Omega$  and  $0.02\ \Omega$  respectively. The leakage reactance of the transformer referred to the primary is  $35\ \Omega$ . Calculate

- (a) the primary voltage required to circulate full-load current when the secondary is short-circuited.  
(b) the full-load regulations at (i) unity (ii) 0.8 lagging p.f. Neglect the no-load current.

[(a) 256 V (b) (i) 2.2% (ii) 3.7%] (*Elect. Technology, Kerala Univ. 1979*)

17. Calculate :

- (a) F.L. efficiency at unity p.f.  
(b) The secondary terminal voltage when supplying full-load secondary current at p.f. (i) 0.8 lag (ii) 0.8 lead for the 4-kVA, 200/400 V, 50 Hz, 1-phase transformer of which the following are the test figures :

Open circuit with 200 V supplied to the primary winding-power 60 W. Short-circuit with 16 V applied to the h.v. winding-current 8 A, power 40 W. [0.97 ; 383 V ; 406 V]

18. A 100-kVA, 6600/250-V, 50-Hz transformer gave the following results :

O.C. test : 900 W, normal voltage.

S.C. test (data on h.v. side) : 12 A, 290 V, 860 W

Calculate

- (a) the efficiency and percentage regulation at full-load at 0.8 p.f. lagging.  
(b) the load at which maximum efficiency occurs and the value of this efficiency at p.f. of unity, 0.8 lag and 0.8 lead. [(a) 97.3%, 4.32% (b) 81 kVA, 97.8%, 97.3% ; 97.3%]

19. The primary resistance of a 440/110-V transformer is  $0.5\ \Omega$  and the secondary resistance is  $0.04\ \Omega$ . When 440 V is applied to the primary and secondary is left open-circuited, 200 W is drawn from the supply. Find the secondary current which will give maximum efficiency and calculate this efficiency for a load having unity power factor.

[53 A ; 93.58%] (*Basic Electricity & Electronics. Bombay Univ. 1981*)

20. Two tests were performed on a 40-kVA transformer to predetermine its efficiency. The results were:

Open circuit : 250 V at 500 W

Short circuit : 40 V at F.L. current, 750 W both tests from primary side.

Calculate the efficiency at rated kVA and 1/2 rated kVA at (i) unity p.f. (ii) 0.8 p.f.

[96.97% ; 96.68% ; 96.24% ; 95.87%]

21. The following figures were obtained from tests on a 30-kVA, 3000/110-V transformer :

O.C. test : 3000 V 0.5 A 350 W ; S.C. test ; 150 V 10 A 500 W

Calculate the efficiency of the transformer at

- (a) full-load, 0.8 p.f. (b) half-load, unity p.f.

Also, calculate the kVA output at which the efficiency is maximum. [96.56% ; 97% ; 25.1 kVA]

22. The efficiency of a 400 kVA, 1-phase transformer is 98.77 % when delivering full load at 0.8 power factor, and 99.13 % at half load and unity power factor. Calculate (a) the iron loss, (b) the full load copper loss. [(a) 1012 W (b) 2973 W] (*Rajiv Gandhi Technical University, 2000*)

### All-day Efficiency

The ordinary or commercial efficiency of a transformer is given by the ratio

$$\frac{\text{Output in watts}}{\text{Input in watts}}$$

But there are certain types of transformers whose performance cannot be judged by this efficiency. Transformers used for supplying lighting and general network *i.e.*, distribution transformers have their primaries energised all the twenty-four hours, although their secondaries supply little or no-load much of the time during the day except during the house lighting period. It means that whereas core loss occurs throughout the day, the Cu loss occurs only when the transformers are loaded. Hence, it is considered a good practice to design such transformers so that core losses are very low. The Cu losses are relatively less important, because they depend on the load. The performance of such is compared on the basis of *energy* consumed during a certain time period, usually a day of 24 hours.



The world first 5,000 KVA amorphous transformer commissioned in August 2001 in Japan

$$\therefore \eta_{\text{all-day}} = \frac{\text{Output in kWh (For 24 hours)}}{\text{Input in kWh}}$$

This efficiency is always less than the commercial efficiency of a transformer.

To find this all-day efficiency or (as it is also called) energy efficiency, we have to know the load cycle on the transformer *i.e.*, how much and how long the transformer is loaded during 24 hours. Practical calculations are facilitated by making use of a **load factor**.

**Example 32.78.** Find the all-day efficiency of 500-kVA distribution transformer whose copper loss and iron loss at full load are 4.5 kW and 3.5 kW respectively. During a day of 24 hours, it is loaded as under :

No. of hours	Loading in kW	Power factor
6	400	0.8
10	300	0.75
4	100	0.8
4	0	—

(Elect. Machines, Nagpur Univ. 1993)

**Solution.** It should be noted that a load of 400 kW at 0.8 p.f. is equal to  $400/0.8 = 500$  kVA. Similarly, 300 kW at 0.75 p.f. means  $300/0.75 = 400$  kVA and 100 kW at 0.8 p.f. means  $100/0.8 = 125$  kVA *i.e.*, one-fourth of the full-load.

Cu loss at F.L. of 500 kVA = 4.5 kW

$$\text{Cu loss at 400 kVA} = 4.5 \times (400/500)^2 = 2.88 \text{ kW}$$

$$\text{Cu loss at 125 kVA} = 4.5 \times (125/500)^2 = 0.281 \text{ kW}$$

$$\begin{aligned} \text{Total Cu loss in 24 hrs} &= (6 \times 4.5) + (10 \times 2.88) + (4 \times 0.281) + (4 \times 0) \\ &= 56.924 \text{ kWh} \end{aligned}$$

The iron loss takes place throughout the day irrespective of the load on the transformer because its primary is energized all the 24 hours.

$$\begin{aligned} \therefore \text{Iron loss in 24 hours} &= 24 \times 3.5 = 84 \text{ kWh} \\ \text{Total transformer loss} &= 56.924 + 84 = 140.924 \text{ kWh} \\ \text{Transformer output in 24 hrs} &= (6 \times 400) + (10 \times 300) + (4 \times 100) = 5800 \text{ kWh} \\ \therefore \eta_{\text{all-day}} &= \frac{\text{output}}{\text{output} + \text{losses}} = \frac{5800}{5800 + 140.924} = 0.976 \text{ or } \mathbf{97.6\%} \end{aligned}$$

**Example 32.79.** A 100-kVA lighting transformer has a full-load loss of 3 kW, the losses being equally divided between iron and copper. During a day, the transformer operates on full-load for 3 hours, one half-load for 4 hours, the output being negligible for the remainder of the day. Calculate the all-day efficiency. **(Elect. Engg. Punjab Univ. 1990)**

**Solution.** It should be noted that lighting transformers are taken to have a load p.f. of unity.

$$\begin{aligned} \text{Iron loss for 24 hours} &= 1.5 \times 24 = 36 \text{ kWh ; F.L. Cu loss} = 1.5 \text{ kW} \\ \therefore \text{Cu loss for 3 hours on F.L.} &= 1.5 \times 3 = 4.5 \text{ kWh} \\ \text{Cu loss at half full-load} &= 1.5/4 \text{ kW} \\ \text{Cu loss for 4 hours at half the load} &= (1.5/4) \times 4 = 1.5 \text{ kWh} \\ \text{Total losses} &= 36 + 4.5 + 1.5 = 42 \text{ kWh} \\ \text{Total output} &= (100 \times 3) + (50 \times 4) = 500 \text{ kWh} \\ \therefore \eta_{\text{all-day}} &= 500 \times 100/542 = \mathbf{92.26\%} \end{aligned}$$

Incidentally, ordinary or commercial efficiency of the transformer is

$$= 100/(100 + 3) = 0.971 \text{ or } \mathbf{97.1\%}$$

**Example 32.80.** Two 100-kW transformers each has a maximum efficiency of 98% but in one the maximum efficiency occurs at full-load while in the other, it occurs at half-load. Each transformer is on full-load for 4 hours, on half-load for 6 hours and on one-tenth load for 14 hours per day. Determine the all-day efficiency of each transformer. **(Elect. Machines-I, Vikram Univ. 1988)**

**Solution.** Let  $x$  be the iron loss and  $y$  the full-load Cu loss. If the ordinary efficiency is a maximum at  $1/m$  of full-load, then  $x = y/m^2$ .

$$\begin{aligned} \text{Now,} \quad \text{output} &= 100 \text{ kW ; Input} = 100/0.98 \\ \therefore \text{Total losses} &= 100/0.98 - 100 = 2.04 \text{ kW} \\ \therefore y + x/m^2 &= 2.04 \end{aligned}$$

#### 1st Transformer

$$\begin{aligned} \text{Here } m &= 1 ; \quad y + y = 2.04 ; y = 1.02 \text{ kW and } x = 1.02 \text{ kW} \\ \text{Iron loss for 24 hours} &= 1.02 \times 24 = 24.48 \text{ kWh} \\ \text{Cu loss for 24 hours} &= 4 \times 1.02 + 6 \times (1.02/4) + 14 (1.02/10^2) = 5.73 \text{ kWh} \\ \text{Total loss} &= 24.48 + 5.73 = 30.21 \text{ kWh} \\ &= 4 \times 100 + 6 \times 50 + 14 \times 10 = 840 \text{ kWh} \\ \therefore \eta_{\text{all-day}} &= 840/870.21 = 0.965 \text{ or } \mathbf{96.5\%} \end{aligned}$$

#### 2nd Transformer

$$\begin{aligned} \text{Here} \quad 1/m &= 1/2 \text{ or } m = 2 \therefore y + y/4 = 2.04 \\ \text{or} \quad y &= 1.63 \text{ kW ; } x = 0.14 \text{ kW} \\ \text{Output} &= 840 \text{ kWh} \quad \dots \text{as above} \\ \text{Iron loss for 24 hours} &= 0.14 \times 24 = 9.84 \text{ kWh} \\ \text{Cu loss for 24 hours} &= 4 \times 1.63 + 6 (1.63/4) + 14 (1.63/10^2) = 9.19 \text{ kWh} \\ \text{Total loss} &= 9.84 + 9.19 = 19.03 \text{ kWh} \\ \therefore \eta_{\text{all-day}} &= 840/859.03 = 0.978 \text{ or } \mathbf{97.8\%} \end{aligned}$$

**Example 32.81.** A 5-kVA distribution transformer has a full-load efficiency at unity p.f. of 95 %, the copper and iron losses then being equal. Calculate its all-day efficiency if it is loaded throughout the 24 hours as follows :

No load for	10 hours	Quarter load for	7 hours
Half load for	5 hours	Full load for	2 hours

Assume load p.f. of unity.

(Power Apparatus-I, Delhi Univ. 1987)

**Solution.** Let us first find out the losses from the given commercial efficiency of the transformer.

$$\text{Output} = 5 \times 1 = 5 \text{ kW} ; \text{Input} = 5/0.95 = 5.264 \text{ kW}$$

$$\text{Losses} = (5.264 - 5.000) = 0.264 \text{ kW} = 264 \text{ W}$$

Since efficiency is maximum, the losses are divided equally between Cu and iron.

$$\therefore \text{Cu loss at F.L. of 5 kVA} = 264/2 = 132 \text{ W} ; \text{Iron loss} = 132 \text{ W}$$

$$\text{Cu loss at one-fourth F.L.} = (1/4)^2 \times 132 = 8.2 \text{ W}$$

$$\text{Cu loss at one-half F.L.} = (1/2)^2 \times 132 = 33 \text{ W}$$

$$\text{Quarter load Cu loss for 7 hours} = 7 \times 8.2 = 57.4 \text{ Wh}$$

$$\text{Half-load Cu loss for 5 hours} = 5 \times 33 = 165 \text{ Wh}$$

$$\text{F.L. Cu loss for 2 hours} = 2 \times 132 = 264 \text{ Wh}$$

$$\text{Total Cu loss during one day} = 57.4 + 165 + 264 = 486.4 \text{ Wh} = 0.486 \text{ kWh}$$

$$\text{Iron loss in 24 hours} = 24 \times 132 = 3168 \text{ Wh} = 3.168 \text{ kWh}$$

$$\text{Total losses in 24 hours} = 3.168 + 0.486 = 3.654 \text{ kWh}$$

Since load p.f. is to be assumed as unity.

$$\text{F.L. output} = 5 \times 1 = 5 \text{ kW} ; \text{Half F.L. output} = (5/2) \times 1 = 2.5 \text{ kW}$$

$$\text{Quarter load output} = (5/4) \times 1 = 1.25 \text{ kW}$$

$$\text{Transformer output in a day of 24 hours} = (7 \times 1.25) + (5 \times 2.5) + (2 \times 5) = 31.25 \text{ kWh}$$

$$\eta_{\text{all-day}} = \frac{31.25}{(31.25 + 3.654)} \times 100 = 89.53 \%$$

**Example 32.82.** Find “all day” efficiency of a transformer having maximum efficiency of 98 % at 15 kVA at unity power factor and loaded as follows :

12 hours – 2 kW at 0.5 p.f. lag

6 hours – 12 kW at 0.8 p.f. lag

6 hours – at no load.

(Elect. Machines-I, Nagpur Univ. 1993)

**Solution.**

$$\text{Output} = 15 \times 1 = 15 \text{ kW}, \text{input} = 15/0.98$$

$$\text{Losses} = (15/0.98 - 15) = 0.306 \text{ kW} = 306 \text{ W}$$

Since efficiency is maximum, the losses are divided equally between Cu and iron.

$$\therefore \text{Cu loss at 15 kVA} = 306/2 = 153 \text{ W}, \text{Iron loss} = 153 \text{ W}$$

$$2 \text{ kW at } 0.5 \text{ p.f.} = 2/0.5 = 4 \text{ kVA}, 12 \text{ kW at } 0.8 \text{ p.f.} = 12/0.8 = 15 \text{ kVA}$$

$$\text{Cu loss at 4 kVA} = 153 (4/15)^2 = 10.9 \text{ W} ; \text{Cu loss at 15 kVA} = 153 \text{ W.}$$

$$\text{Cu loss in 12 hrs} = 12 \times 10.9 = 131 \text{ Wh} ; \text{Cu loss in 6 hr} = 6 \times 153 = 918 \text{ Wh.}$$

$$\text{Total Cu loss for 24 hr} = 131 + 918 = 1050 \text{ Wh} = 1.05 \text{ kWh}$$

$$\text{Iron loss for 24 hrs} = 24 \times 153 = 3,672 \text{ Wh} = 3.672 \text{ kWh}$$

$$\text{Output in 24 hrs} = (2 \times 12) + (6 \times 12) = 96 \text{ kWh}$$

$$\text{Input in 24 hrs} = 96 + 1.05 + 3.672 = 100.72 \text{ kWh}$$

$$\therefore \eta_{\text{all-day}} = 96 \times 100/100.72 = 95.3 \%$$

**Example 32.83.** A 150-kVA transformer is loaded as follows :

Load increases from zero to 100 kVA in 3 hours from 7 a.m. to 10.00 a.m., stays at 100 kVA from 10 a.m. to 6 p.m. and then the transformer is disconnected till next day. Assuming the load to be resistive and core-loss equal to full-load copper loss of 1 kW, determine the all-day efficiency and the ordinary efficiency of the transformer. **(Electrical Machines-II, Indore Univ. 1990)**

**Solution.** Since load is resistive, its p.f. is unity.

Average load from 7 a.m. to 10 a.m. =  $(0 + 100)/2 = 50$  kVA *i.e.*, one-third F.L.

Load from 10 a.m. to 6 p.m. = 100 kVA *i.e.*, 2/3 of F.L.

**Ordinary Efficiency**

In this case, load variations are not relevant.

Output =  $150 \times 1 = 150$  kW ; Iron loss = Cu loss = 1 kW ; Total loss = 2 kW.

$\therefore$  Ordinary  $\eta = 150/(150 + 2) = 0.9868$  or **98.68%**

**All-day Efficiency**

Cu loss from 7-10 a.m. =  $3 \times (1/3)^2 \times 1 = 0.333$  kWh

Cu loss from 10 a.m. to 6 p.m. =  $8 \times (2/3)^2 \times 1 = 3.555$  kWh

Total Cu loss for 24 hrs =  $0.333 + 3.555 = 3.888$  kWh

Total iron loss for 24 hrs =  $24 \times 1 = 24$  kWh

Losses for a day of 24 hrs = 27.888 kWh

Output for 24 hrs =  $3 \times (50 \times 1) + 8 (100 \times 1) = 950$  kWh

$\therefore \eta_{\text{all-day}} = \frac{950 \times 100}{(950 + 27.888)} = \mathbf{97.15\%}$

**Example 32.84.** Find the all-day efficiency of a 50 kVA distribution transformer having full load efficiency of 94 % and full-load copper losses are equal to the constant iron losses. The loading of the transformer is as follows, the power factor being 1.0.

(i) No load for 10 hours (ii) Half load for 5 hours

(iii) 25 % load for 6 hours (iv) Full load for 3 hours. **(Sambalpur University, 1998)**

**Solution.** At full load unity p.f.

$$\text{efficiency} = 94\% = \frac{50,000}{50,000 + 2P_i}$$

$$2P_i = \frac{50,000}{0.94} - 50,000, \text{ or } P_i = \frac{1}{2} \times 50,000 \left[ \frac{1-0.94}{0.94} \right],$$

$$P_i = 25,000 \times \frac{0.06}{0.94} = 1596 \text{ Watts}$$

Hence, full load Cu-losses = 1596 Watts

(a) Energy required in overcoming Cu-losses, during 24 hours

(i) No load for 10 hours : zero

(ii) At half load, Cu-losses =  $(0.5)^2 \times 1596$  Watts = 399

Energy in 5 hours =  $\frac{399 \times 5}{1000}$  kWh = 1.995 kWh

(iii) At 25 % load, Cu-loss =  $(0.25)^2 \times 1596 = 99.75$  Watts

Energy in 6 hours =  $\frac{6 \times 99.75}{1000} = 0.5985$  kWh

(iv) Energy lost during 3 hours of full load =  $\frac{1596 \times 3}{1000} = 4.788$  kWh

(b) Energy lost in constant core-losses for 24 hours =  $\frac{1596}{1000} \times 24 = 38.304$  kWh

(c) Energy required by the load =  $25 \times 5 + 12.5 \times 6 + 50 \times 3 = 125 + 75 + 150 = 350 \text{ kWh}$   
 All-day efficiency =  $\frac{350}{350 + 38.304 + 7.3815} \times 100 = 88.454 \%$

**Example 32.85.** A 10 kVA, 1-ph transformer has a core-loss of 40 W and full load ohmic loss of 100 W. The daily variation of load on the transformer is as follows :

6 a.m. to 1 p.m. 3 kW at 0.60 p.f.  
 1 p.m. to 5 p.m. - 8kW at 0.8 p.f.  
 5 p.m. to 1 a.m. full load at u.p.f.  
 1 a.m. to 6 a.m. no load

Determine all day efficiency of the transformer (Amravati University, 1999)

**Solution.** Fractional loading (= x) and the output kWh corresponding to load variations can be worked out in tabular form, as below :

S.N.	Number of hours	$x = \frac{\text{load kVA}}{\text{Xmer Rating}}$	$x^2 P_c \text{ in kW}$	Output in kWh	Copper Loss in kWh
1	7	$\frac{3/0.6}{10} = 0.5$	$0.5^2 \times 0.10 = 0.025$	$3 \times 7 = 21$	$0.025 \times 7 = 0.175$
2	4	$\frac{8/0.8}{10} = 1.0$	0.10	$8 \times 4 = 32$	$0.1 \times 4 = 0.40$
3	8	$\frac{10/1}{10} = 1.0$	0.10	$10 \times 8 = 80$	$0.1 \times 8 = 0.8$
4	5	Zero	Zero	Zero	Zero
Output in kWh				$21 + 32 + 80 = 133$	
Ohmic Loss, in kWh					$0.175 + 0.40 + 0.80 = 1.375$
Core loss during 24 Hrs = $\frac{40}{1000} \times 24 = 0.96 \text{ kWh}$					

Hence, Energy efficiency (= All day Efficiency) =  $\frac{133}{133 + 1.375 + 0.96} \times 100 = 98.3 \%$

**Example 32.86.** A transformer has its maximum efficiency of 0.98 at 15 kVA at unity p.f. During a day, it is loaded as follows :

12 hours : 2 kW at 0.8 p.f.  
 6 hours : 12 kW at 0.8 p.f.  
 6 hours : 18 kW at 0.9 p.f.

Find the all day efficiency. (Manomaniam Sundaranar Univ. April 1998)

**Solution.** Let 15 kVA be treated as full load.

Output at maximum efficiency =  $15000 \times 1 \text{ watts}$

Input =  $15000/0.98 \text{ watts}$

Losses = Input – Output =  $15000 (1/0.98 - 1) = 15000 \times 2/98 = 306 \text{ Watts}$

At maximum efficiency, since the variable copper-loss and constant core-loss are equal.

Full load copper-loss = Constant core-loss =  $306/2 = 153 \text{ Watts}$

Let the term x represents the ratio of required Load/Full load.

Output =  $15 \times \cos \phi$



Following tabular entries simplify the calculations for all-day efficiency.

S.N.	$x$	Hrs	$x^2 P_c$ in kW	Energy in Copper-loss in kWh	Output during the period in kWh
1	$\frac{2/0.5}{15} = \frac{4}{15}$	12	0.01088	0.131	24
2	$\frac{12/0.8}{15} = 1.0$	6	0.153	0.918	72
3	$\frac{18/0.9}{15} = 4/3$	6	0.272	1.632	108

Total output during the day = 204 kWh

Total copper-loss during the day = 2.681 kWh

Total core-loss during the day =  $0.153 \times 24 = 3.672$

All day efficiency =  $(204/210.353) \times 100 = 96.98\%$

### Tutorial Problems 32.5

1. A 100-kVA distribution transformer has a maximum efficiency of 98 % at 50 % full-load and unity power factor. Determine its iron losses and full-load copper losses.

The transformer undergoes a daily load cycle as follows :

Load	Power factor	Load duration
100 kVA	1.0	8 hrs
50 kVA	0.8	6 hrs
No load		10 hrs

Determine its all-day efficiency.

(Electrical Engineering, MS Univ. Baroda 1979)

2. What is meant by energy efficiency of a transformer ?

A 20-kVA transformer has a maximum efficiency of 98 percent when delivering three-fourth full-load at u.p.f. If during the day, the transformer is loaded as follows :

12 hours	No load
6 hours	12 kWh, 0.8 p.f.
6 hours	20 kW, u.p.f.

Calculate the energy efficiency of the transformer.

(Electrical Technology-III, Gwalior Univ., 1980)

### Auto-transformer

It is a transformer with one winding only, part of this being common to both primary and secondary. Obviously, in this transformer the primary and secondary are not electrically *isolated* from each other as is the case with a 2-winding transformer. But its theory and operation are similar to those of a two-winding transformer. Because of one winding, it uses less copper and hence is cheaper. It is used where transformation ratio differs little from unity. Fig. 32.60 shows both step down and step-up auto-transformers.

As shown in Fig. 32.60 (a),  $AB$ , is primary winding having  $N_1$  turns and  $BC$  is secondary winding having  $N_2$  turns. Neglecting iron losses and no-load current.

$$\frac{V_2}{V_1} = \frac{N_2}{N_1} = \frac{I_1}{I_2} = K$$

The current in section *CB* is vector difference\* of  $I_2$  and  $I_1$ . But as the two currents are practically in phase opposition, the resultant current is  $(I_2 - I_1)$  where  $I_2$  is greater than  $I_1$ .

As compared to an ordinary 2-winding transformer of same output, an auto-transformer has higher efficiency but smaller size. Moreover, its voltage regulation is also superior.

**Saving of Cu**

Volume and hence weight of Cu, is proportional to the length and area of the cross-section of the conductors.

Now, length of conductors is proportional to the number of turns and cross-section depends on current. Hence, weight is proportional to the product of the current and number of turns.

With reference to Fig. 32.60,

Wt. of Cu in section *AC* is  $\propto (N_1 - N_2) I_1$ ; Wt. of Cu in section *BC* is  $\propto N_2 (I_2 - I_1)$ .

$\therefore$  Total Wt. of Cu in auto-transformer  $\propto (N_1 - N_2) I_1 + N_2 (I_2 - I_1)$

If a two-winding transformer were to perform the same duty, then

Wt. of Cu on its primary  $\propto N_1 I_1$ ; Wt. of Cu on secondary  $\propto N_2 I_2$

Total Wt. of Cu  $\propto N_1 I_1 + N_2 I_2$

$$\therefore \frac{\text{Wt. of Cu in auto-transformer}}{\text{Wt. of Cu in ordinary transformer}} = \frac{(N_1 - N_2) I_1 + N_2 (I_2 - I_1)}{N_1 I_1 + N_2 I_2}$$

$$= 1 - \frac{2 \frac{N_2}{N_1} I_1}{1 + \frac{2}{N_1} \times \frac{2}{I_1}} = 1 - \frac{2K}{2} = 1 - K \left( \begin{matrix} N_1 = K; I_2 = \frac{1}{K} \\ \frac{N_2}{N_1} = \frac{1}{K}; I_1 = K \end{matrix} \right)$$

Wt. of Cu in auto-transformer ( $W_a$ )  
 $= (1 - K) \times$  (Wt. of Cu in ordinary transformer  $W_0$ )

$$\therefore \text{Saving} = W_0 - W_a = W_0 - (1 - K) W_0 = K W_0$$

$\therefore$  Saving =  $K \times$  (Wt. of Cu in ordinary transformer)

Hence, saving will increase as  $K$  approaches unity.

It can be proved that power transformed **inductively** is input  $(1 - K)$ .

The rest of the power =  $(K \times \text{input})$  is **conducted** directly from the source to the load *i.e.*, it is transferred **conductively** to the load.

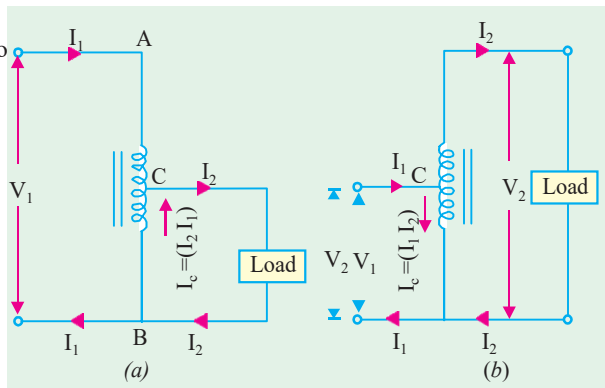

Fig. 32.60



Step up auto-transformer

\* In fact, current flowing in the common winding of the auto-transformer is always equal to the difference between the primary and secondary currents of an ordinary transformer.

**Uses**

As said earlier, auto-transformers are used when  $K$  is nearly equal to unity and where there is no objection to electrical connection between primary and secondary. Hence, such transformers are used :

1. to give small boost to a distribution cable to correct the voltage drop.
2. as auto-starter transformers to give upto 50 to 60 % of full voltage to an induction motor during starting.
3. as furnace transformers for getting a convenient supply to suit the furnace winding from a 230-V supply
4. as interconnecting transformers in 132 kV/330 kV system.
5. in control equipment for 1-phase and 3-phase electrical locomotives.

**Example 32.87.** An auto-transformer supplies a load of 3 kW at 115 volts at a unity power factor. If the applied primary voltage is 230 volts, calculate the power transferred to the load

(a) inductively and (b) conductively. (Basic Elect. Machines, Nagpur Univ, 1991)

**Solution.** As seen from Art 32.33

Power transferred inductively = Input  $(1 - K)$

Power transferred conductively = Input  $\times K$

Now,  $K = 115/230 = 1/2$ , input  $\cong$  output = 3 kW

$\therefore$  Inductively transferred power =  $3(1 - 1/2) = 1.5 \text{ kW}$

Conductively transferred power =  $(1/2) \times 3 = 1.5 \text{ kW}$

**Example 32.88.** The primary and secondary voltages of an auto-transformer are 500 V and 400 V respectively. Show with the aid of diagram, the current distribution in the winding when the secondary current is 100 A and calculate the economy of Cu in this particular case.

**Solution.** The circuit is shown in Fig, 30.61.

$$K = V_2/V_1 = 400/500 = 0.8$$

$$\therefore I_1 = KI_2 = 0.8 \times 100 = 80 \text{ A}$$

The current distribution is shown in Fig. 32.61.

Saving =  $K W_0 = 0.8 W_0$  - Art 32.33

$\therefore$  Percentage saving =  $0.8 \times 100 = 80$

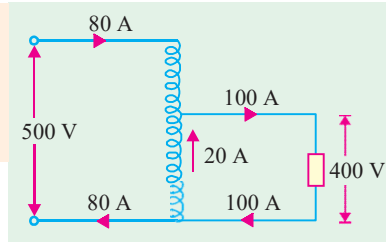

Fig. 32.61

**Example 32.89.** Determine the core area, the number of turns and the position of the tapping point for a 500-kVA, 50-Hz, single-phase, 6,600/5,000-V auto-transformer, assuming the following approximate values : e.m.f. per turn 8 V. Maximum flux density 1.3 Wb/m<sup>2</sup>.

**Solution.**

$$E = 4.44 f \Phi_m N \text{ volt}$$

$$\Phi_m = \frac{E/N}{4.44 f} = \frac{8}{4.44 \times 50} = 0.03604 \text{ Wb}$$

$$\text{Core area} = 0.03604/1.3 = 0.0277 \text{ m}^2 = 277 \text{ cm}^2$$

Turns of h.v. side =  $6600/8 = 825$  ; Turns of L.V. side =  $5000/8 = 625$

Hence, tapping should be 200 turns from high voltage end or 625 turns from the common end.

**Conversion of 2-Winding Transformer into Auto-transformer**

Any two-winding transformer can be converted into an auto-transformer either step-down or step-up. Fig. 32.62 (a) shows such a transformer with its polarity markings. Suppose it is a 20-kVA,

2400/240 V transformer. If we employ **additive** polarity between the high-voltage and low-voltage sides, we get a step-up auto-transformer. If, however, we use the **subtractive** polarity, we get a step-down auto-transformer.

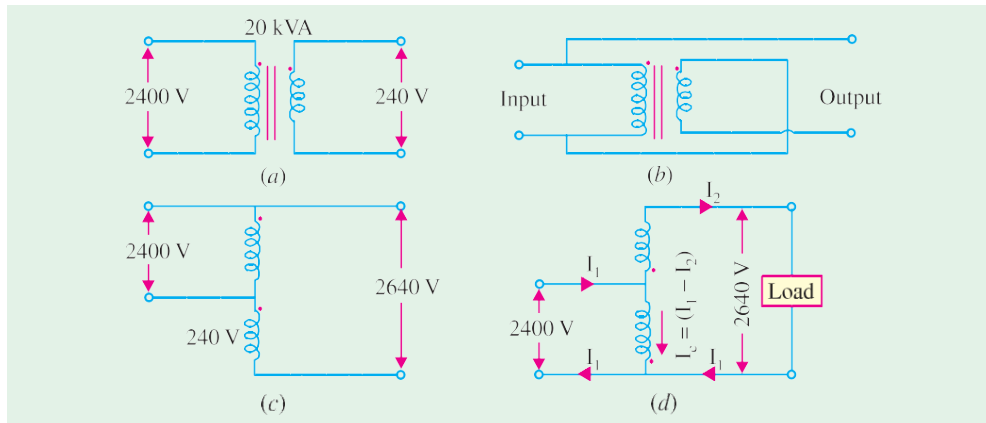

Fig. 32.62

**(a) Additive Polarity**

Connections for such a polarity are shown in Fig. 32.62 (b). The circuit is re-drawn in Fig. 32.62 (c) showing common terminal of the transformer at the top whereas Fig. 32.62 (d) shows the same circuit with common terminal at the bottom. Because of additive polarity,  $V_2 = 2400 + 240 = 2640$  V and  $V_1$  is 2400 V. There is a marked increase in the kVA of the auto-transformer (Ex. 32.90). As shown in Fig. 32.62 (d), common current flows **towards** the common terminal. The transformer acts as a step-up transformer.

**(b) Subtractive Polarity**

Such a connection is shown in Fig. 32.63 (a). The circuit has been re-drawn with common polarity at top in Fig. 32.63 (b) and at bottom in Fig. 32.63 (c). In this case, the transformer acts as a step-down auto-transformer.

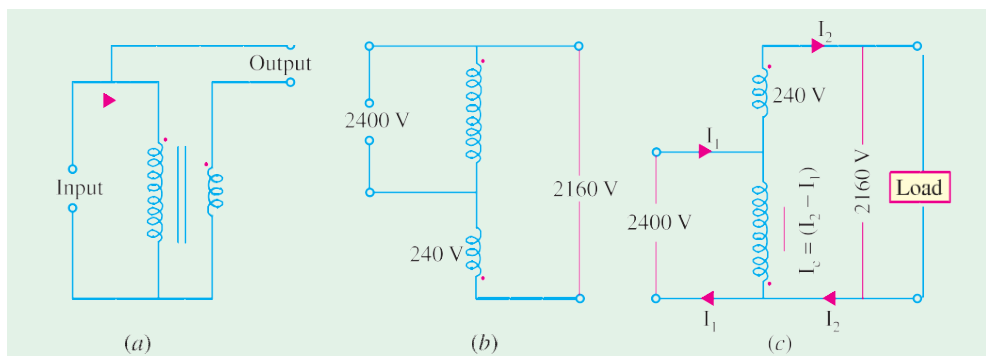

Fig. 32.63

The common current flows **away** from the common terminal. As will be shown in Example 32.91, in this case also, there is a very large increase in kVA rating of the auto-transformer though not as marked as in the previous case. Here,  $V_2 = 2400 - 240 = 2160$  V.

**Example 32.90.** For the 20-kVA, 2400/240-V two-winding step-down transformer shown in Fig. 32.63 (a) connected as an auto-transformer with additive polarity as shown in Fig. 30.61 (d), compute

- (i) original current capacity of HV-windings.
- (ii) original current capacity of LV-windings.
- (iii) kVA rating of auto-transformer using current capacity of current LV winding as calculated in (ii) above.
- (iv) per cent increase in kVA capacity of auto-transformer as compared to original two-winding transformer.
- (v) values of  $I_1$  and  $I_c$  in Fig. 30.61 (d) from value of  $I_2$  used in (iii) above.
- (vi) per cent overload of 2400-V winding when used as an auto-transformer.
- (vii) comment on the results obtained.

**Solution.** (i)  $I_1 = 20 \times 10^3 / 2400 = 8.33 \text{ A}$  (ii)  $I_2 = I / K = 8.33 \times 10 = 83.3 \text{ A}$

(iii) kVA rating of auto-transformer  $V_2 I_2 = 2640 \times 83.3 \times 10^{-3} = 220 \text{ kVA}$

(iv) Per cent increase in kVA rating =  $\frac{220}{20} \times 100 = 1100\%$

(v)  $I_1 = 220 \times 10^3 / 2400 = 91.7 \text{ A}$ ,  $I_c = I_1 - I_2 = 91.7 - 83.3 = 8.4 \text{ A}$

(vi) Per cent overload of 2400 V winding =  $8.4 \times 100 / 8.33 = 100.8\%$

(vii) As an auto-transformer, the kVA has increased tremendously to 1100% of its original value with LV coil at its rated current capacity and HV coil at negligible overload i.e.  $1.008 \times$  rated load.

**Example 32.91.** Repeat Example 30.64 for subtractive polarity as shown in Fig. 32.62 (c).

**Solution.** (i)  $I_1 = 8.33 \text{ A}$  (ii)  $I_2 = 83.3 \text{ A}$

(iii) New kVA rating of auto-transformer is  $2160 \times 83.3 \times 10^{-3} = 180 \text{ kVA}$

(iv) Per cent increase in kVA rating =  $\frac{180}{20} \times 100 = 900\%$

(v)  $I_1 = 180 \times 10^3 / 2400 = 75 \text{ A}$ ,  $I_c = I_2 - I_1 = 83.3 - 75 = 8.3 \text{ A}$

(vi) Per cent overload of 2400V winding =  $8.3 \times 100 / 8.33 = 100\%$

(vii) In this case, kVA has increased to 900% of its original value as a two-winding transformer with both low-voltage and high-voltage windings carrying their rated currents.

The above phenomenal increase in kVA capacity is due to the fact that in an auto-transformer energy transfer from primary to secondary is by both conduction as well as induction whereas in a 2-winding transformer it is by induction only. This extra conductive link is mainly responsible for the increase in kVA capacity.

**Example 32.92.** A 5-kVA, 110/110-V, single-phase, 50-Hz transformer has full-load efficiency of 95% and an iron loss of 50 W. The transformer is now connected as an auto-transformer to a 220-V supply. If it delivers a 5-kW load at unity power factor to a 110-V circuit, calculate the efficiency of the operation and the current drawn by the high-voltage side.

(Electric Machinery-II, Bangalore Univ. 1991)

**Solution.** Fig. 32.64 (a) shows the normal connection for a 2-winding transformer. In Fig. 32.64 (b) the same unit has been connected as an auto transformer. Since the two windings are connected in series, voltage across each is 110 V.

The iron loss would

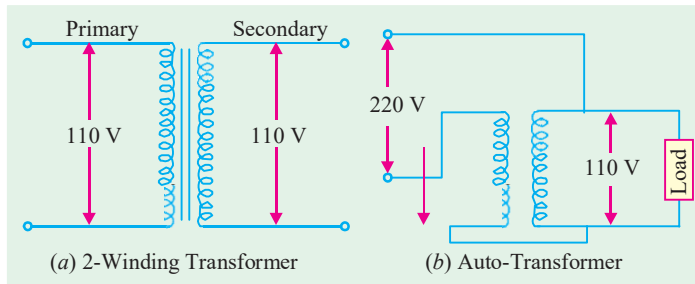

Fig. 32.64

remain the same in both connections. Since the auto-transformer windings will each carry but half the current as compared to the conventional two-winding transformer, the copper loss will be one-fourth of the previous value.

**Two-winding Transformer**

$$\eta = 0.95 \quad \therefore 0.95 = \frac{\text{output}}{\text{output} + \text{losses}} = \frac{5,000}{5,000 + 50 + \text{Cu loss}}$$

$$\therefore \text{Cu loss} = 212 \text{ W}$$

**Auto-transformer**

$$\text{Cu loss} = 212/4 = 53 \text{ W}; \text{ Iron loss} = 50 \text{ W} \quad \therefore \eta = \frac{5,000}{5,000 + 53 + 50} = 0.9797 \text{ or } 97.97\%$$

$$\text{Current of the h.v. side} = 5103/220 = 23.2 \text{ A}$$

**Example 32.93.** A transformer has a primary voltage rating of 11500 volts and secondary voltage rating of 2300 volts. Two windings are connected in series and the primary is connected to a supply of 11500 volts, to act as a step-up auto transformer. Determine the voltage output of the transformer.

*Question extended :* If the two winding transformer is rated at 115 kVA, what will be the kVA rating of the auto-transformer ? **(Madras University, 1997)**

**Solution.** As in Fig. 32.65 (a), 115 kVA, 11500/2300 V, transformer has the current ratings of 10 A and 50 A.

Referring to Fig. 32.65 (b), the step-up connections have been shown. Winding currents have to be at the same rated values. As in Fig. 32.65 (b), the voltage obtainable at  $B_1 - B_2$  is 13800 V, and from  $b_1$  a load-current of 50 A can be supplied.

$$\text{kVA rating} = 13800 \times 50 \times 10^{-3} = 690$$

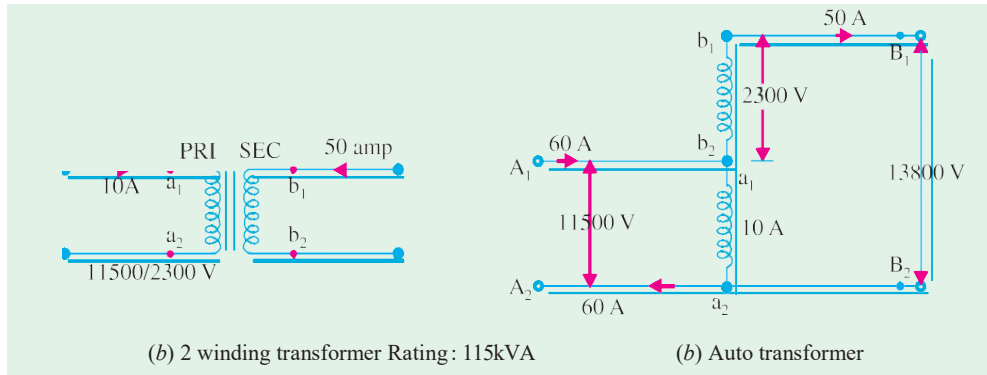

Fig. 32.65

**Example 32.94.** An 11500/2300 V transformer is rated at 100 kVA as a 2 winding transformer. If the two windings are connected in series to form an auto-transformer, what will be the possible voltage ratios ? **(Manonmaniam Sundaranar Univ. April 1998)**

**Solution.** Fig. 32.66 (a) shows this 2-winding transformer with rated winding currents marked .

$$\text{Rated current of 11.5 kV winding} = 100 \times 100/11500 = 8.7 \text{ Amp}$$

$$\text{Rated current of 2300 V winding} = 43.5 \text{ Amp}$$

Fig. 32.66 (b) and Fig. 32.66 (c) show autotransformer

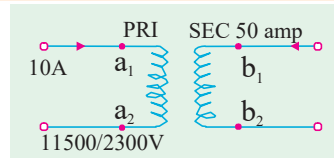

Fig. 32.66 (a). 2 winding transformer

connections. On H.V. side, they have a rating of 13.8 kV. On L.V. side, with connection as in Fig. 32.66 (b), the rating is 2300 V. On L.V. side of Fig. 32.66 (c), the output is at 11.5 kV.

Thus, possible voltage ratios are : 13800/2300 V and 13800/11500 V.

With both the connections, step-up or step-down versions are possible.

**Extension of Question :** Calculate kVA ratings in the two cases.

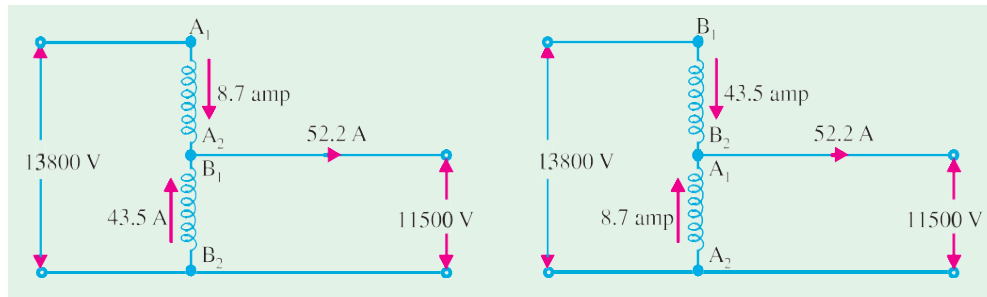

Fig. 32.66

Windings will carry the rated currents, while working out kVA outputs.

In Fig. 32.66 (b), Input current (into terminal  $A_1$  of windings  $A_1-A_2$ ) can be 8.7 Amp with H.V. -side-voltage ratings as 13.8 kV. Transformation ratio =  $13800/2300 = 6$

Hence, kVA rating =  $13.8 \times 8.7 = 120$

Output current =  $120 \times 1000/2300 = 52.2$  Amp

Current in the winding  $B_1-B_2$   
 = Difference of Output current and Input current  
 =  $52.2 - 8.7 = 43.5$  A, which is the rated current of the winding  $B_1-B_2$ .

In Fig. 32.66 (c). Similarly, transformation ratio =  $13800/11500 = 1.2$

kVA rating =  $13800 \times 43.5 \times 10^{-3} = 600$

Output current =  $600 \times 1000/11500 = 52.2$  Amp

Current carried by common winding =  $52.2 - 43.5 = 8.7$  A, which is rated current for the winding  $A_1-A_2$ . Thus, with the same two windings give, a transformation ratio closer to unity gives higher kVA rating as an auto transformer.

Thus, a 100 kVA two winding transformer is reconnected as an autotransformer of 120 kVA with transformation ratio as 6, and becomes a 600 kVA autotransformer with transformation ratio as 1.2.

**Example 32.95.** A two-winding transformer is rated at 2400/240 V, 50-kVA. It is re-connected as a step-up auto-transformer, with 2400 V input. Calculate the rating of the auto-transformer and the inductively and conductively transferred powers while delivering the rated output at unity power-factor.

(Nagpur University, Winter 1999)

**Solution.** With 50 kVA as the rating, the rated currents on the two sides are 20.8 A (2400-V side) and 208 A (240 - V side). With the required re-connection, the 2400-V winding will work as a common winding. As shown in Fig. 32.67, the winding common to input and output can carry 20.8 A, the output current can be 208 A with a voltage of 2640 V, which means that the output of this auto

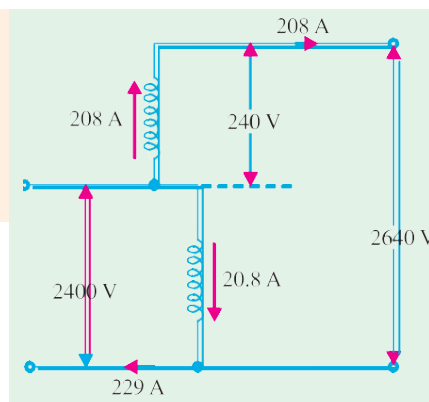

Fig. 32.67

transformer is  $(2640 \times 208) = 550 \text{ kVA}$ .

The corresponding input-current is  
 $(208 \times 2640/2400) = 229 \text{ A}$ .

The ratio of turns in this case is given by

$$k = 2640/2400 = 1.1$$

With the step-up job, and  $k = 1.1$

$$\frac{\text{Rating of Auto-transformer}}{\text{Rating as two-winding transformer}} = \frac{k}{k-1} = \frac{1.1}{0.1}$$

This gives the rating as auto-transformer of 550 kVA.

At unity power-factor, the rated load = 550 kW.

Out of this, the “*inductively*” transferred power

= Power handled by the common winding

$$= (2400 \text{ V}) \times (20.8 \text{ A}) \times 10^{-3} = 50 \text{ kW.}$$

= Rated output as a two-winding transformer.

$$\text{Remaining Power} = 550 \text{ kW} - 50 \text{ kW} = 500 \text{ kW.}$$

This power of 500 kW is “*conductively*” transferred as is clear from the division of currents at the input node. Out of the total current of 229 A from the source, 208 A goes straight to the output. The remaining current of 20.8 A is through the “*common*” and “*inductive*” path, as marked in the Fig. 32.67.

### Parallel Operation of Single-phase Transformers

For supplying a load in excess of the rating of an existing transformer, a second transformer may be connected in parallel with it as shown in Fig. 32.68. It is seen that primary windings are connected to the supply bus bars and secondary windings are connected to the load bus-bars. In connecting two or more than two transformers in parallel, it is essential that their terminals of similar polarities are joined to the same bus-bars as in Fig. 32.68. If this is not done, the two e.m.fs. induced in the secondaries which are paralleled with incorrect polarities, will act together in the local secondary circuit even when supplying no load and will hence produce the equivalent of a dead short-circuit as shown in Fig. 32.69.

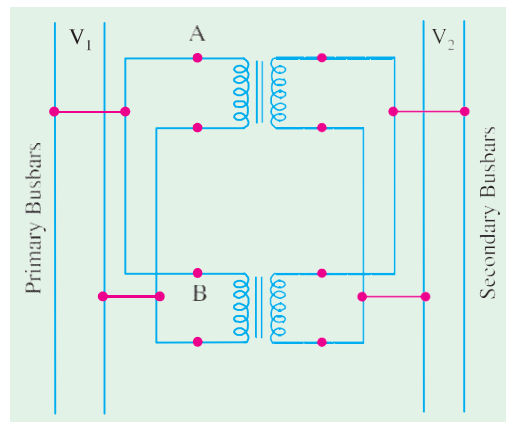

Fig. 32.68

There are certain definite conditions which must be satisfied in order to avoid any local circulating currents and to ensure that the transformers share the common load in proportion to their kVA ratings. The conditions are :

1. Primary windings of the transformers should be suitable for the supply system voltage and frequency.
2. The transformers should be properly connected with regard to polarity.
3. The voltage ratings of both primaries and secondaries should be identical. In other words, the transformers should have the same turn ratio *i.e.* transformation ratio.
4. The percentage impedances should be equal in magnitude and have the same X/R ratio in order to avoid circulating currents and operation at different power factors.



5. With transformers having different kVA ratings, the equivalent impedances should be inversely proportional to the individual kVA rating if circulating currents are to be avoided.

Of these conditions, (1) is easily comprehended ; condition (2) is absolutely essential (otherwise paralleling with incorrect polarities will result in dead short-circuit). There is some latitude possible with conditions (3) and (4). If condition (3) is not exactly satisfied *i.e.* the two transformers have slightly different transformation or voltage ratios, even then parallel operation is possible. But due to inequality of induced e.m.fs. in secondaries, there will be even on no-load, some circulating current between them (and therefore between the primary windings also) when secondary terminals are connected in parallel. When secondaries are loaded, this localized circulating current will tend to produce unequal loading condition. Hence, it may be impossible to take full kVA output from the parallel connected group without one of the transformers becoming over-heated.

If condition (4) is not exactly satisfied *i.e.* impedance triangles are not identical in shape and size, parallel operation will still be possible, but the power factors at which the two transformers operate will be different from the power factor of the common load. Therefore, in this case, the two transformers will not share the load in proportion to their kVA ratings.

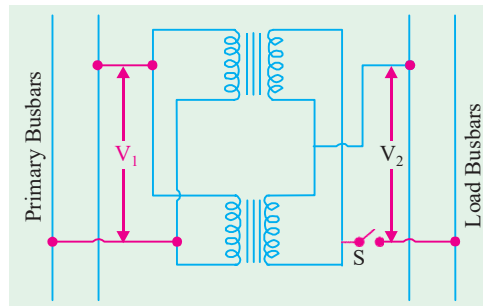

Fig. 32.69

It should be noted that the impedances of two transformers may differ in magnitude and in quality (*i.e.* ratio of equivalent resistance to reactance). It is worthwhile to distinguish between the *percentage* and *numerical* value of an impedance. For example, consider two transformers having ratings in the ratio 1 : 2. It is obvious that to carry double the current, the latter must have half the impedance of the former for the same regulation. For parallel operation, the regulation must be the same, this condition being enforced by the very fact of their being connected in parallel. It means that the currents carried by the two transformers are proportional to their ratings provided their *numerical* impedances are inversely proportional to these ratings and their *percentage* impedances are identical.

If the *quality* of the two percentage impedances is different (*i.e.* ratio of percentage resistance to reactance is different), then this will result in divergence of phase angle of the two currents, with the result that one transformer will be operating with a higher and the other with a lower power factor than that of the combined load.

**(a) Case 1. Ideal Case**

We will first consider the ideal case of two transformers having the same voltage ratio and having impedance voltage triangles identical in size and shape.

Let  $E$  be the no-load secondary voltage of each transformer and  $V_2$  the terminal voltage ;  $I_A$  and  $I_B$  the currents supplied by them and  $I$  the total current, lagging behind  $V_2$  by an angle  $\phi$  (Fig. 32.70(a))

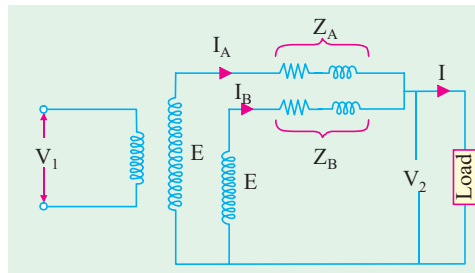

Fig. 32.70 (a)

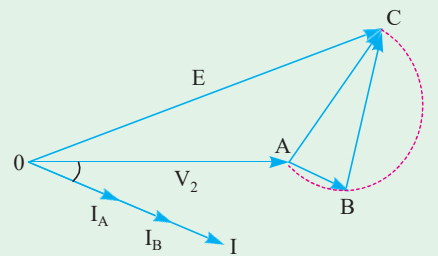

Fig. 32.70 (b)

In Fig. 32.70 (b) a single triangle  $ABC$  represents the identical impedance voltage triangles of both the transformers. The currents  $I_A$  and  $I_B$  of the individual transformers are in phase with the load current  $I$  and are inversely proportional to the respective impedances. Following relations are obvious.

$$I = I_A + I_B; V_2 = E - I_A Z_A = E - I_B Z_B = E - I Z_{AB}$$

Also

$$I_A Z_A = I_B Z_B \text{ or } I_A / I_B = Z_B / Z_A$$

$\therefore$

$$I_A = I Z_B / (Z_A + Z_B) \text{ and } I_B = I Z_A / (Z_A + Z_B)$$

**(b) Case 2. Equal Voltage Ratios**

Let us assume that no-load voltages of both secondaries is the same *i.e.*  $E_A = E_B = E$ , and that the two voltages are coincident *i.e.* there is no phase difference between  $E_A$  and  $E_B$ , which would be true if the magnetising currents of the two transformers are not much different from each other. Under these conditions, both primaries and secondaries of the two transformers can be connected in parallel and there will circulate no current between them on **on-load**.

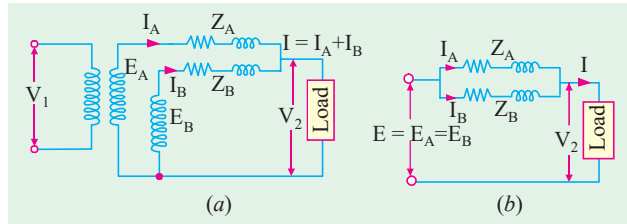

Fig. 32.71

However, if we neglect the magnetising admittances, the two transformers can be connected as shown by their equivalent circuits in Fig. 32.71. The vector diagram is shown in Fig. 32.72.

From Fig. 32.71 (a) or (b) it is seen that it represents two impedances in parallel. Considering all values **consistently with reference to secondaries**, let

$Z_A, Z_B$  = impedances of the transformers

$I_A, I_B$  = their respective currents

$V_2$  = common terminal voltage

$I$  = combined current

It is seen that  $I_A Z_A = I_B Z_B = I Z_{AB}$  ... (i)

where  $Z_{AB}$  is the combined impedance of  $Z_A$  and  $Z_B$  in parallel.

$$1/Z_{AB} = 1/Z_A + 1/Z_B$$

Hence  $Z_{AB} = Z_A Z_B / (Z_A + Z_B)$  ... (ii)

From equation (i), we get

$$Z_A = I Z_{AB} \text{ and } Z_B = I Z_{AB} / I_B \text{ and } I_B = I Z_{AB} / Z_B = I Z_A / (Z_A + Z_B)$$

Multiplying both sides by common terminal voltage  $V_2$ , we have

$$V_2 I_A = V_2 I \frac{Z_B}{Z_A + Z_B}; \text{ Similarly } V_2 I_B = V_2 I \frac{Z_A}{Z_A + Z_B}$$

Let  $V_2 I \times 10^{-3} = S$  - the combined load kVA. Then, the kVA carried by each transformer is

$$S_A = S \frac{Z_B}{Z_A + Z_B} = S \frac{1}{1 + \frac{Z_A}{Z_B}} \text{ and } S_B = S \frac{Z_A}{Z_A + Z_B} = S \frac{1}{1 + \frac{Z_B}{Z_A}} \text{ ... (iii)}$$

Hence,  $S_A$  and  $S_B$  are obtained in magnitude as well as in phase from the above vectorial expressions.

The above problem may be solved graphically, although somewhat more laboriously. As shown in Fig. 32.72, drawn  $I_A$  and  $I_B$  with an angular difference of  $(\phi_A - \phi_B)$  and magnitude (according to some suitable scale) inversely proportional to the respective impedances. Vector sum of  $I_A$  and  $I_B$  gives total combined current  $I$ . The phase angle and magnitude of  $I$  will be known from the conditions of loading, so that angle  $\phi$

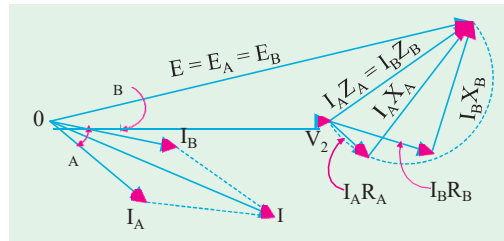

Fig. 32.72

between  $V_2$  and  $I$  will be known. Inserting this, the transformer currents  $I_A$  and  $I_B$  become known in magnitude and phase with respect to  $V_2$ .

**Note. (a)** In equation (iii) above, it is not necessary to use the ohmic values of resistances and reactances, because only impedance ratios are required.

**(b)** The two percentage impedances must be adjusted to the same kVA in the case of transformers of different rating as in Ex. 32.101.

**(c)** From equation (iii) above, it is seen that if two transformers having the same rating and the same transformation ratio are to share the load equally, then their impedances should be equal *i.e.* equal resistances and reactances and not numerical equality of impedances. In general, for transformers of different ratings but same transformation ratio, their equivalent impedances must be inversely proportional to their ratings if each transformer is to assume a load in proportion to its rating. For example, as said earlier, a transformer operating in parallel with another of twice the rating, must have an impedance twice that of the large transformer in order that the load may be properly shared between them.

**Example 32.96.** Two 1-phase transformers with equal turns have impedances of  $(0.5 + j3)$  ohm and  $(0.6 + j10)$  ohm with respect to the secondary. If they operate in parallel, determine how they will share a total load of 100 kW at p.f. 0.8 lagging? (**Electrical Technology, Madras Univ. 1987**)

**Solution.**  $Z_A = 0.5 + j3 = 3.04 \angle 80.6^\circ$   $Z_B = 0.6 + j10 = 10.02 \angle 86.6^\circ$

$$Z_A + Z_B = 1.1 + j13 = 13.05 \angle 85.2^\circ$$

Now, a load of 100 kW at 0.8 p.f. means a kVA of  $100/0.8 = 125$ . Hence,

$$S = 125 \angle -36.9^\circ$$

$$S_A = S \frac{Z_B}{Z_A + Z_B} = \frac{125 \angle -36.9^\circ \times 10.02 \angle 86.6^\circ}{13.05 \angle 85.2^\circ} = 96 \angle -35.5^\circ$$

= a load of  $96 \times \cos 35.5^\circ = 78.2$  kW

$$S_B = S \frac{Z_A}{Z_A + Z_B} = \frac{125 \angle -36.9^\circ \times 3.04 \angle 80.6^\circ}{13.05 \angle 85.2^\circ} = 29.1 \angle -41.5^\circ$$

= a load of  $29.1 \times \cos 41.5^\circ = 21.8$  kW

**Note.** Obviously, transformer A is carrying more than its due share of the common load.

**Example 32.97.** Two single-phase transformers A and B are connected in parallel. They have same kVA ratings but their resistances are respectively 0.005 and 0.01 per unit and their leakage reactances 0.05 and 0.04 per unit. If A is operated on full-load at a p.f. of 0.8 lagging, what will be the load and p.f. of B? (**A.C. Machines-I, Jadavpur Univ. 1985**)

**Solution.** In general,  $S_A = S \frac{Z_B}{Z_A + Z_B}$  and  $S_B = S \frac{Z_A}{Z_A + Z_B}$

where  $S$  is the total kVA supplied and  $Z_A$  and  $Z_B$  are the percentage impedances of these transformers.

$$\frac{S_B}{S_A} = \frac{Z_A}{Z_B}$$

Now,  $Z_A = 0.005 + j0.05$  per unit ; %  $Z_A = 0.5 + j5$  and %  $Z_B = 1 + j4$

Let  $S_A = S_A \angle -36.87^\circ$

where  $S_A$  represents the rating of transformer A (and also of B).

$$\begin{aligned} S_B &= S_A \angle -36.87^\circ \times \frac{(0.5 + j5)}{(1 + j4)} \\ &= S_A \angle -36.87^\circ \times \frac{20.7}{17} \angle 8.3^\circ = 1.22 S_A \angle -28.57^\circ \end{aligned}$$

It is obvious that transformer  $B$  is working **22%** over-load and its power factor is

$$\cos 28.57^\circ = \mathbf{0.878 \text{ (lag)}}$$

**Example 32.98.** Two 1-phase transformers  $A$  and  $B$  rated at 250 kVA each are operated in parallel on both sides. Percentage impedances for  $A$  and  $B$  are  $(1 + j 6)$  and  $(1.2 + j 4.8)$  respectively. Compute the load shared by each when the total load is 500 kVA at 0.8 p.f. lagging.

(Electrical Machines-II, Indore Univ. 1989)

**Solution.**

$$\frac{Z_A}{Z_A + Z_B} = \frac{1 + j 6}{2.2 + j 10.8} = 0.55 \angle 2.1^\circ; \quad \frac{Z_B}{Z_A + Z_B} = \frac{1.2 + j 4.8}{2.2 + j 10.8} = 0.45 \angle -2.5^\circ$$

$$S_A = S \frac{Z_B}{Z_A + Z_B} = 500 \angle -36.9^\circ \times 0.45 \angle -2.5^\circ = \mathbf{225 \angle -39.4^\circ}$$

$$S_B = S \frac{Z_A}{Z_A + Z_B} = 500 \angle -36.9^\circ \times 0.55 \angle 2.1^\circ = \mathbf{275 \angle -34.8^\circ}$$

Obviously, transformer  $B$  is overloaded to the extent of  $(275 - 250) \times 100/250 = 10\%$ . It carries  $(275/500) \times 100 = 55\%$  of the total load.

**Example 32.99.** Two 100-kW, single-phase transformers are connected in parallel both on the primary and secondary. One transformer has an ohmic drop of 0.5% at full-load and an inductive drop of 8% at full-load current. The other has an ohmic drop of 0.75% and inductive drop of 2%. Show how will they share a load of 180 kW at 0.9 power factor.

(Elect. Machines-I, Calcutta Univ. 1988)

**Solution.** A load of 180 kW at 0.9 p.f. means a kVA of  $180/0.9 = 200$

$\therefore$  Load

$$S = 200 \angle -25.8^\circ$$

$$\begin{aligned} \frac{Z_1}{Z_1 + Z_2} &= \frac{(0.5 + j 8)}{(1.25 + j 12)} = \frac{(0.5 + j 8)(1.25 - j 12)}{1.25^2 + 12^2} \\ &= \frac{96.63 + j 4}{145.6} = \frac{96.65 \angle 2.4^\circ}{145.6} = 0.664 \angle 2.4^\circ \end{aligned}$$

$$\begin{aligned} \frac{Z_2}{Z_1 + Z_2} &= \frac{(0.75 + j 4)(1.25 - j 12)}{145.6} \\ &= \frac{48.94 - j 4}{145.6} = \frac{49.1 \angle -5^\circ}{145.6} \\ &= 0.337 \angle -5^\circ \end{aligned}$$

$$S_1 = S \frac{Z_2}{Z_1 + Z_2} = 200 \angle -25.8^\circ \times 0.337 \angle -5^\circ = 67.4 \angle -30.8^\circ$$

$\therefore$

$$kW_1 = 67.4 \times \cos 30.8^\circ = 67.4 \times 0.859 = 57.9 \text{ kW}$$

$$S_2 = 200 \angle -25.8^\circ \times 0.664 \angle 2.4^\circ = 132.8 \angle -23.4^\circ$$

$$kW_2 = 132.8 \times \cos 23.4^\circ = 132.8 \times 0.915 = 121.5 \text{ kW}$$

**Note.** Second transformer is working 21.5% over-load. Also, it shares 65.7% of the total load.

**Example 32.100.** A load of 200 kW at 0.85 power factor lagging is to be shared by two transformers  $A$  and  $B$  having the same ratings and the same transformation ratio. For transformer  $A$ , the full-load resistive drop is 1% and reactance drop 5% of the normal terminal voltage. For transformer  $B$  the corresponding values are : 2% and 6%. Calculate the load kVA supplied by each transformer.

**Solution.**

$$Z_A = 1 + j 5; \quad Z_B = Z + j 6$$

$$\frac{Z_A}{Z_B} = \frac{1+j5}{2+j6} = 0.8 + j0.1; \quad \frac{Z_B}{Z_A} = \frac{2+j6}{1+j5} = 1.23 - j0.514$$

Load

$$\text{kVA} = \text{kW/p.f.} = 200/0.85 = 235$$

$$\text{kVA} = S = 235(0.85 - j0.527) \\ = 200 - j123.8 \quad (\cos \phi = 0.85; \sin \phi = 0.527)$$

$$S_A = S \frac{Z_B}{Z_A + Z_B} = S \frac{1}{1 + (Z_A/Z_B)} \\ = \frac{200 - j123.8}{1 + (0.8 + j0.1)} = \frac{200 - j123.8}{1.8 + j0.1} = 107.3 - j74.9$$

$$S_A = \sqrt{(107.3^2 + 74.9^2)} = 131; \cos \phi_A = 107.3/131 = 0.82 \text{ (lag)}$$

Similarly

$$S_B = S \frac{Z_A}{Z_A + Z_B} = S \frac{1}{1 + (Z_B/Z_A)} \\ = \frac{200 - j123.8}{1 + (1.23 - j0.514)} = \frac{200 - j123.8}{2.23 - j0.154} = 93 - j49$$

∴

$$S_B = \sqrt{(93^2 + 49^2)} = 105; \cos \phi_B = 90/105 = 0.888 \text{ (lag)}$$

(As a check,  $S = S_A + S_B = 131 + 105 = 236$ . The small error is due to approximations made in calculations.)

**Example 32.101.** Two 2,200/110-V, transformers are operated in parallel to share a load of 125 kVA at 0.8 power factor lagging. Transformers are rated as below :

A : 100 kVA ; 0.9% resistance and 10% reactance

B : 50 kVA ; 1.0% resistance and 5% reactance

Find the load carried by each transformer.

(Elect. Technology, Utkal Univ. 1989)

**Solution.** It should be noted that the percentages given above refer to different ratings. As pointed out in Art. 32.35, these should be adjusted to the same basic kVA, say, 100 kVA.

$$\% Z_A = 0.9 + j10; \quad \% Z_B = (100/50)(1 + j5) = (2 + j10) \\ \frac{Z_A}{Z_A + Z_B} = \frac{0.9 + j10}{(202.6 + j11)} = \frac{(0.9 + j10)(2.9 - j20)}{(202.9 - 3.1j)} = \frac{202.9 \angle -3.1^\circ}{408.4} = 0.4968 \angle 3.1^\circ \\ \frac{Z_B}{Z_A + Z_B} = \frac{(2 + j10)(2.9 - j20)}{408.4} = \frac{206 - j11}{408.4} \\ = \frac{206.1 \angle -3.1^\circ}{408.4} = 0.504 \angle -3.1^\circ$$

Also

$$\cos \phi = 0.8, \phi = \cos^{-1}(0.8) = 36.9^\circ$$

$$S_A = S \frac{Z_B}{Z_A + Z_B} = 125 \angle -36.9^\circ \times 0.504 \angle -3.1^\circ = 63 \angle -40^\circ$$

$$S_B = S \frac{Z_A}{Z_A + Z_B} = 125 \angle -36.9^\circ \times 0.4968 \angle 3.1^\circ = 62.1 \angle -33.8^\circ$$

**Example 32.102.** A 500-kVA transformer with 1% resistance and 5% reactance is connected in parallel with a 250-kVA transformer with 1.5% resistance and 4% reactance. The secondary voltage of each transformer is 400 V on no-load. Find how they share a load of 750-kVA at a p.f. of 0.8 lagging. (Electrical Machinery-I, Madras Univ. 1987)

**Solution.** It may be noted that percentage drops given above refer to different ratings. These should be adjusted to the same basic kVA i.e. 500 kVA.

$$\% Z_A = 1 + j5 = 5.1 \angle 78.7^\circ; \% Z_B = \left(\frac{500}{250}\right)(1.5 + j4) = 3 + j8 = 8.55 \angle 69.4^\circ$$

$$\%(Z_A + Z_B) = 4 + j13 = 13.6 \angle 72.9^\circ; S = 750 \angle -36.9^\circ$$

$$S_A = S \frac{Z_B}{Z_A + Z_B} = \frac{750 \angle -36.9^\circ \times 8.55 \angle 69.4^\circ}{13.6 \angle 72.9^\circ} = 470 \angle -40.4^\circ$$

= 470 kVA at p.f. of 0.762 lagging

$$S_B = S \frac{Z_A}{Z_A + Z_B} = \frac{750 \angle -36.9^\circ \times 5.1 \angle 78.7^\circ}{13.6 \angle 72.9^\circ} = 280 \angle -31.1^\circ$$

= 280 kVA at p.f. 0.856 lagging

**Note.** The above solution has been attempted vectorially, but in practice, the angle between  $I_A$  and  $I_B$  is so small that if instead of using vectorial expressions, arithmetic expressions were used, the answer would not be much different. In most cases, calculations by both vectorial and arithmetical methods generally yield results that do not differ sufficiently to warrant the more involved procedure by the vector solution. The above example will now be attempted arithmetically :

$$Z_A = 5.1 \Omega, Z_B = 8.55 \Omega; I_A/I_B = Z_B/Z_A = 8.55/5.1 = 1.677 \therefore I_A = 1.677 I_B$$

Total current = 750,000/400 = 1875 A

$$I = I_A + I_B; 1875 = 1.677 I_B + I_B = 2.677 I_B \therefore I_B = 1875/2.677$$

$\therefore$

$$S_B = 400 \times 1875/2.677 \times 100 = 280 \text{ kVA}$$

$$I_A = 1.677 \times 1875/2.677$$

$$S_A = 400 \times 1.677 \times 1875/2.677 \times 1000 = 470 \text{ kVA}$$

**Example 32.103.** Two single-phase transformers A and B of equal voltage ratio are running in parallel and supply a load of 1000 A at 0.8 p.f. lag. The equivalent impedances of the two transformers are  $(2 + j3)$  and  $(2.5 + j5)$  ohms respectively. Calculate the current supplied by each transformer and the ratio of the kW output of the two transformers. (Electrical Machines-I, Bombay Univ. 1986)

**Solution.**

$$Z_A = (2 + j3), Z_B = (2.5 + j5)$$

$$\text{Now, } \frac{I_A}{I_B} = \frac{Z_B}{Z_A} = \frac{2.5 + j5}{2 + j3} = (1.54 + j0.2); I_A = I_B (1.54 + j0.2)$$

Taking secondary terminal voltage as reference vector, we get

$$I = 1000(0.8 - j0.6) = 800 - j600 = 200(4 - j3)$$

Also,

$$I = I_A + I_B = I_B(1.54 + j0.2) + I_B = I_B(2.54 + j0.2)$$

$\therefore$

$$200(4 - j3) = I_B(2.54 + j0.2); I_B = 294.6 - j259.5 = 392.6 \angle -41.37^\circ$$

$$I_A = I_B(1.54 + j0.2) = (294.6 - j259.5)(1.54 + j0.2) = 505.6 - j340.7$$

$$= 609.7 \angle -33.95^\circ$$

The ratio of the kW output is given by the ratio of the in-phase components of the two currents.

$$\frac{\text{output of A}}{\text{output of B}} = \frac{505.6}{294.6} = \frac{1.7}{1}$$

**Note.** Arithmetic solution mentioned above could also be attempted.

**Example 32.104.** Two transformers *A* and *B*, both of no-load ratio 1,000/500-V are connected in parallel and supplied at 1,000 V. *A* is rated at 100 kVA, its total resistance and reactance being 1% and 5% respectively, *B* is rated at 250 kVA, with 2% resistance and 2% reactance. Determine the load on each transformer and the secondary voltage when a total load of 300 kVA at 0.8 power factor lagging is supplied.

**Solution.** Let the percentage impedances be adjusted to the common basic kVA of 100.

Then  $\%Z_A = (1 + j 5)$ ;  $\%Z_B = (100/250)(2 + j 2) = (0.8 + j 0.8)$

$$\frac{Z_A}{Z_A + Z_B} = \frac{1 + j 5}{(1.8 + j 5.8)} = 0.839 \angle 5.9^\circ$$

$$\frac{Z_B}{Z_A + Z_B} = \frac{0.8 + j 0.8}{(1.8 + j 5.8)} = 0.1865 \angle -27.6^\circ$$

Now,  $S = 300 \angle -36.9^\circ = 240 - j 180$

$$S_A = S \cdot \frac{Z_B}{Z_A + Z_B} = 300 \angle -36.9^\circ \times 0.1865 \angle -27.6^\circ = 55.95 \angle -64.5^\circ$$

$$S_B = S \cdot \frac{Z_A}{Z_A + Z_B} = 300 \angle -36.9^\circ \times 0.839 \angle 5.9^\circ = 251.7 \angle -31^\circ$$

Since  $Z_A$  and  $Z_B$  are in parallel, their combined impedance on 100 kVA basis is

$$Z_{AB} = \frac{Z_A Z_B}{Z_A + Z_B} = \frac{(1 + j 5)(0.8 + j 0.8)}{(1.8 + j 5.8)} = 0.6 + j 0.738$$

Percentage drop over  $Z_{AB}$  is  $\frac{(0.6 \times 240/100) + (0.738 \times 180/100)}{500 - \frac{500 \times 2.768}{100}} = 1.44 + 1.328 = 2.768\%$   
 $\therefore V_2 = 500 - \frac{500 \times 2.768}{100} = 486.12 \text{ V}$

**Example 32.105.** Two 1- $\phi$  transformers are connected in parallel at no-load. One has a turn ratio of 5,000/440 and a rating of 200 kVA, the other has a ratio of 5,000/480 and a rating of 350 kVA. The leakage reactance of each is 3.5%.

What is the no-load circulation current expressed as a percentage of the nominal current of the 200 kVA transformer.

**Solution.** The normal currents are

$$200 \times 10^3 / 440 = 455 \text{ A and } 350 \times 10^3 / 480 = 730 \text{ A}$$

Reactances seen from the secondary side are

$$\frac{3.5}{100} \times \frac{440}{455} = 0.034 \Omega, \quad \frac{3.5}{100} \times \frac{480}{730} = 0.023 \Omega$$

The difference of induced voltage is 40 V. The circulating current is

$$I_c = 40 / 0.057 = 704 \text{ A} = 1.55 \text{ times the normal current of 200 kVA unit.}$$

### Tutorial Problems 32.6

- Two single-phase transformers *A* and *B* of equal voltage ratio are running in parallel and supplying a load requiring 500 A at 0.8 power factor lagging at a terminal voltage of 400 V. The equivalent impedances of the transformers, as referred to secondary windings, are  $(2 + j 3)$  and  $(2.5 + j 5)$  ohm. Calculate the current supplied by each transformer.

(Note. The student is advised to try by arithmetic method also).  $[I_A = 304 \text{ A}; I_B = 197 \text{ A}]$

- Two single-phase transformers *A* and *B* are operating in parallel and supplying a common load of 1000 kVA at 0.8 p.f. lagging. The data regarding the transformers is as follows :

Transformer	Rating	%Resistance	% Reactance
A	750 kVA	3	5
B	500 kVA	2	4

Determine the loading of each transformer.  $[S_A = 535 \angle -34.7^\circ ; S_B = 465 \angle -39.3^\circ]$

3. Two transformers *A* and *B* give the following test results. With the low-tension side short-circuited, *A* takes a current of 10 A at 200 V, the power input being 1000 W. Similarly, *B* takes 30 A at 200 V ; the power input being 1,500 W. On open circuit, both transformers give a secondary voltage of 2200 when 11,000 volts are applied to the primary terminals. These transformers are connected in parallel on both high tension and low tension sides Calculate the current and power in each transformer when supplying a load of 200 A at 0.8 power factor lagging. The no-load currents may be neglected.

(Hint : Calculate  $Z_A$  and  $Z_B$  from S.C. test data)

$[I_A = 50.5 \text{ A}, P_A = 100 \text{ kW} ; I_B = 151 \text{ A}, P_B = 252 \text{ kW}]$  (London University)

4. Two 6600/250-V transformers have the following short-circuit characteristics : Applied voltage 200 V, current 30 A, power input 1,200 W for one of the transformers ; the corresponding data for the other transformer being 120 V, 20 A and 1,500 W. All values are measured on the H.V. side with the L.V. terminals short circuited. Find the approximate current and the power factor of each transformer when working in parallel with each other on the high and low voltage sides and taking a total load of 150 kW at a p.f. of 0.8 lagging from the high voltage bus-bars.

$[I_A = 13.8 \text{ A}, \cos \phi_A = 0.63 ; I_B = 15.35 \text{ A}, \cos \phi_B = 0.91]$  (Electrical Engg-IV, Baroda Univ. 1978)

5. Two 11,000/2,200-V, 1-phase transformers are connected in parallel to supply a total load of 200 at 0.8 p.f. lagging at 2,200 V. One transformer has an equivalent resistance of 0.4  $\Omega$  and equivalent reactance of 0.8  $\Omega$  referred to the low-voltage side. The other has equivalent resistance of 0.1  $\Omega$  and a reactance of 0.3  $\Omega$ . Determine the current and power supplied by each transformer.

$[52 \text{ A} ; 148 \text{ A} ; 99 \text{ A} ; 252 \text{ kW}]$

6. A 2,000-kVA transformer (*A*) is connected in parallel with a 4,000-kVA transformer (*B*) to supply a 3-phase load of 5,000 kVA at 0.8 p.f. lagging. Determine the kVA supplied by each transformer assuming equal no-load voltages. The percentage volt drops in the windings at the rated loads are as follows :

Transformer *A* : resistance 2% ; reactance 8%

Transformer *B* : resistance 1.6% ; reactance 3%

$[A : 860 \text{ kVA}, 0.661 \text{ lag} ; B : 4170 \text{ kVA}, 0.824 \text{ lag}]$  (A.C. Machines-I, Jadavpur Univ. 1979)

7. Two single-phase transformers work in parallel on a load of 750 A at 0.8 p.f. lagging. Determine secondary voltage and the output and power factor of each transformer. Test data are :

Open circuit : 11,00/13,300 V for each transformer

Short circuit : with h.v. winding short-circuit

Transformer *A* : secondary input 200 V, 400 A, 15 kW

Transformer *B* : secondary input 100 V, 400 A, 20 kW

$[3,190 \text{ VA} ; 80 \text{ kVA}, 0.65 \text{ lag} ; B : 1,615 \text{ kVA} ; 0.86 \text{ lag}]$

### (c) Case 3. Unequal Voltage Ratios

In this case, the voltage ratios (or transformation ratios) of the two transformers are different. It means that their no-load secondary voltages are unequal. Such cases can be more easily handled by phasor algebra than graphically.

Let  $E_A, E_B$  = no-load secondary e.m.f.s of the two transformers.

$Z_L$  = load impedance across the secondary.

The equivalent circuit and vector diagram are also shown in Fig. 32.73 and 32.74.

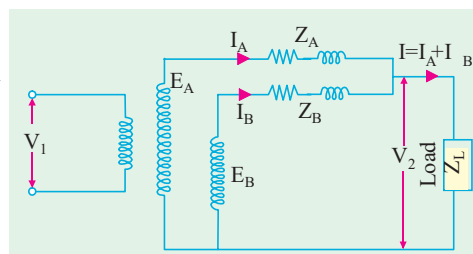

Fig. 32.73



It is seen that even when secondaries are on no-load, there will be some cross-current in them because of inequality in their induced e.m.fs. This circulating current  $I_C$  is given by

$$I_C = (E_A - E_B)/(Z_A + Z_B) \quad \dots(i)$$

As the induced e.m.fs. of the two transformers are equal to the total drops in their respective circuits.

$$\therefore Z_A = I_A Z_A + V_2; E_B = I_B Z_B + V_2$$

Now,  $V_2 = I Z_L = (I_A + I_B) Z_L$

where  $Z_L =$  load impedance

$$E_A = I_A Z_A + (I_A + I_B) Z_L \quad \dots(ii)$$

$$E_B = I_B Z_B + (I_A + I_B) Z_L \quad \dots(iii)$$

$$\therefore E_A - E_B = I_A Z_A - I_B Z_B \quad \dots(iv)$$

$$I_A = [(E_A - E_B) + I_B Z_B]/Z_A$$

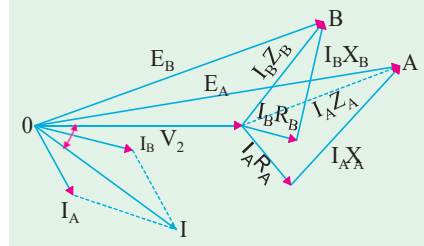

Fig. 32.74

Substituting this value of  $I_A$  in equation (iii), we get

$$E_B = I_B Z_B + \{[(E_A - E_B) + I_B Z_B]/Z_A + I_B\} Z_L \quad \dots(v)$$

$$I_B = [E_B Z_A - (E_A - E_B) Z_L] / [Z_A Z_B + Z_L (Z_A + Z_B)]$$

From the symmetry of the expression, we get

$$I_A = [E_A Z_B + (E_A - E_B) Z_L] / [Z_A Z_B + Z_L (Z_A + Z_B)] \quad \dots(vi)$$

Also,  $I = I_A + I_B = \frac{E_A Z_B + E_B Z_A}{Z_A Z_B + Z_L (Z_A + Z_B)}$

By multiplying the numerator and denominator of this equation by  $1/Z_A Z_B$  and the result by  $Z_L$  we get

$$V_2 = I Z_L = \frac{E_A/Z_A + E_B/Z_B}{1/Z_A + 1/Z_B + 1/Z_L}$$

The two equations (v) and (vi) then give the values of secondary currents. The primary currents may be obtained by the division of transformation ratio *i.e.*  $K$  and by addition (if not negligible) of the no-load current. Usually,  $E_A$  and  $E_B$  have the same phase (as assumed above) but there may be some phase difference between the two due to some difference of internal connection in parallel of a star/star and a star/delta 3-phase transformers.

If  $Z_A$  and  $Z_B$  are small as compared to  $Z_L$  *i.e.* when the transformers are not operated near short-circuit conditions, then equations for  $I_A$  and  $I_B$  can be put in a simpler and more easily understandable form. Neglecting  $Z_A Z_B$  in comparison with the expression  $Z_L (Z_A + Z_B)$ , we have

$$I_A = \frac{E_A Z_B}{Z_L (Z_A + Z_B)} + \frac{E_A - E_B}{Z_A + Z_B} \quad \dots(vii)$$

$$I_B = \frac{E_B Z_A}{Z_L (Z_A + Z_B)} - \frac{E_A - E_B}{Z_A + Z_B} \quad \dots(viii)$$

The physical interpretation of the second term in equations (vii) and (viii) is that it represents the cross-current between the secondaries. The first term shows how the actual load current divides between the loads. The value of current circulating in transformer secondaries (even when there is no-load) is given by\*  $I_C = (E_A - E_B)/(Z_A + Z_B)$  assuming that  $E_A > E_B$ . It lags behind  $E_A$  by an angle  $\alpha$  given by  $\tan \alpha = (X_A + X_B)/(R_A + R_B)$ . If  $E_A + E_B$  the ratios of the currents are inversely as the impedances (numerical values).

\* Under load conditions, the circulating current is

$$I_C = \frac{E_A - E_B}{Z_A + Z_B + Z_A Z_B / Z_L}$$

If

$Z_L = \infty$  *i.e.* on open-circuit, the expression reduces to that given above.

If in Eq. (iv) we substitute  $\mathbf{I}_B = \mathbf{I} - \mathbf{I}_A$  and simplify, we get

$$\mathbf{I}_A = \frac{\mathbf{I}\mathbf{Z}_B}{\mathbf{Z}_A + \mathbf{Z}_B} + \frac{\mathbf{E}_A - \mathbf{E}_B}{\mathbf{Z}_A + \mathbf{Z}_B} \quad \dots(ix)$$

Similarly, if we substitute  $\mathbf{I}_A = \mathbf{I} - \mathbf{I}_B$  and simplify, then

$$\mathbf{I}_B = \frac{\mathbf{I}\mathbf{Z}_A}{\mathbf{Z}_A + \mathbf{Z}_B} + \frac{\mathbf{E}_A - \mathbf{E}_B}{\mathbf{Z}_A + \mathbf{Z}_B} \quad \dots(x)$$

In a similar manner, value of terminal voltage  $V_2$  is given by

$$\mathbf{V}_2 = \mathbf{I}\mathbf{Z}_L = \frac{\mathbf{E}_A\mathbf{Z}_B + \mathbf{E}_B\mathbf{Z}_A - \mathbf{I}\mathbf{Z}_A\mathbf{Z}_B}{\mathbf{Z}_A + \mathbf{Z}_B} \quad \dots(xi)$$

These expressions give the values of transformer currents and terminal voltage in terms of the load current. The value of  $V_2$  may also be found as under :

As seen from Fig. 30.70.

$$\mathbf{I}_A = (\mathbf{E}_A - V_2)/\mathbf{Z}_A = (\mathbf{E}_A - V_2)\mathbf{Y}_A; \mathbf{I}_B = (\mathbf{E}_B - V_2)\mathbf{Y}_B$$

$$\mathbf{I} = V_2\mathbf{Y}_L = \mathbf{I}_A + \mathbf{I}_B \text{ or } V_2\mathbf{Y}_L = (\mathbf{E}_A - V_2)\mathbf{Y}_A + (\mathbf{E}_B - V_2)\mathbf{Y}_B$$

$$\therefore \quad \mathbf{V}_2(\mathbf{Y}_L + \mathbf{Y}_A + \mathbf{Y}_B) = \mathbf{E}_A\mathbf{Y}_A + \mathbf{E}_B\mathbf{Y}_B \text{ or } \mathbf{V}_2 = \frac{\mathbf{E}_A\mathbf{Y}_A + \mathbf{E}_B\mathbf{Y}_B}{\mathbf{Y}_L + \mathbf{Y}_A + \mathbf{Y}_B} \quad \dots(xii)$$

Eq. (xi) gives  $V_2$  in terms of load current. But if only load kVA is given, the problem becomes more complicated and involves the solution of a quadratic equation in  $V_2$ .

Now,  $\mathbf{S} = \mathbf{V}_2\mathbf{I}$ . When we substitute this value of  $\mathbf{I}$  in Eq. (xi), we get

$$\mathbf{V}_2 = \frac{\mathbf{E}_A\mathbf{Z}_B + \mathbf{E}_B\mathbf{Z}_A - \mathbf{S}\mathbf{Z}_A\mathbf{Z}_B/\mathbf{V}_2}{\mathbf{Z}_A + \mathbf{Z}_B}$$

$$\text{or} \quad \mathbf{V}_2^2(\mathbf{Z}_A + \mathbf{Z}_B) - \mathbf{V}_2(\mathbf{E}_A\mathbf{Z}_B + \mathbf{E}_B\mathbf{Z}_A) + \mathbf{S}\mathbf{Z}_A\mathbf{Z}_B = 0$$

When  $V_2$  becomes known, then  $\mathbf{I}_A$  and  $\mathbf{I}_B$  may be directly found from

$$\mathbf{V}_2 = \mathbf{E}_A - \mathbf{I}_A\mathbf{Z}_A \text{ and } \mathbf{V}_2 = \mathbf{E}_B - \mathbf{I}_B\mathbf{Z}_B.$$

**Note.** In the case considered above, it is found more convenient to work with numerical values of impedances instead of % values.

**Example 32.106.** Two transformers A and B are joined in parallel to the same load. Determine the current delivered by each transformer having given : open-circuit e.m.f. 6600 V for A and 6,400 V for B. Equivalent leakage impedance in terms of the secondary =  $0.3 + j3$  for A and  $0.2 + j1$  for B. The load impedance is  $8 + j6$ . (Elect. Machines-I, Indore Univ. 1987)

**Solution.** 
$$\mathbf{I}_A = \frac{\mathbf{E}_A\mathbf{Z}_B + (\mathbf{E}_A - \mathbf{E}_B)\mathbf{Z}_L}{\mathbf{Z}_A\mathbf{Z}_B + \mathbf{Z}_L(\mathbf{Z}_A + \mathbf{Z}_B)}$$

Here  $\mathbf{E}_A = 6,600 \text{ V}$  ;  $\mathbf{E}_B = 6,400 \text{ V}$  ;  $\mathbf{Z}_L = 8 + j6$  ;  $\mathbf{Z}_A = 0.3 + j3$  ;  $\mathbf{Z}_B = 0.2 + j1$

$$\mathbf{I}_A = \frac{6600(0.2 + j1) + (6600 - 6400)(8 + j6)}{(0.3 + j3)(0.2 + j1) + (8 + j6)(0.3 + j3 + 0.2 + j1)}$$

117 - j 156 = 195A in magnitude

Similarly,

$$\begin{aligned} \mathbf{I}_B &= \frac{\mathbf{E}_B\mathbf{Z}_A - (\mathbf{E}_A - \mathbf{E}_B)\mathbf{Z}_L}{\mathbf{Z}_A\mathbf{Z}_B + \mathbf{Z}_L(\mathbf{Z}_A + \mathbf{Z}_B)} \\ &= \frac{6400(0.3 + j3) - (6600 - 6400)(8 + j6)}{(0.3 + j3) + (0.2 + j1)(8 + j6) + (0.5 + j4)} \\ &= 349 - j 231 = 421 \text{ A (in magnitude)} \end{aligned}$$

**Example 32.107.** Two 1- $\phi$  transformers, one of 100 kVA and the other of 50 kVA are connected in parallel to the same bus-bars on the primary side, their no-load secondary voltages being 1000 V and 950 V respectively. Their resistances are 2.0 and 2.5 per cent respectively and their reactances 8 and 6 per cent respectively. Calculate no-load circulating current in the secondaries.

(Adv. Elect Machines, A.M.I.E. Sec. B, 1991)

**Solution.** The circuit connections are shown in Fig. 32.75.

**1st transformer**

Normal secondary current =  $100,000/1000 = 100$  A

$$R_A = \frac{1000 \times 2.0}{100 \times 100} = 0.2 \Omega ; X_A = \frac{1000 \times 8}{100 \times 100} = 0.8 \Omega$$

**2nd Transformer**

Normal secondary current =  $50,000/950 = 52.63$  A

$$R_B = 950 \times 2.5/100 \times 52.63 = 0.45 \Omega$$

$$X_B = 950 \times 6/100 \times 52.63 = 1.08 \Omega$$

Combined impedance of the two secondaries is

$$Z = \sqrt{(R_A + R_B)^2 + (X_A + X_B)^2}$$

$$= \sqrt{0.65^2 + 1.88^2} = 1.99 \Omega$$

$$\therefore I_c = (1000 - 950)/1.99 = 25.1 \text{ A} ; \alpha = \tan^{-1} (1.88/0.65) = 71^\circ$$

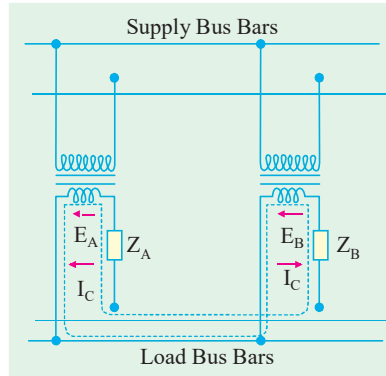

Fig. 32.75

**Example 32.108.** Two single-phase transformers, one of 1000-kVA and the other of 500-kVA are connected in parallel to the same bus-bars on the primary side ; their no-load secondary voltages being 500 V and 510 V respectively. The impedance voltage of the first transformer is 3% and that of the second 5%. Assuming that ratio of resistance to reactance is the same and equal to 0.4 in each. What will be the cross current when the secondaries are connected in parallel ?

(Electrical Machines-I, Madras Univ. 1985)

**Solution.** Let us first determine the ohmic value of the two impedances. Also, let the secondary voltage be 480 V\*.

Full-load

$$I_A = 1000 \times 1000/480 = 2083 \text{ A} ; \text{F.L. } I_B = 500 \times 1000/480 = 1042 \text{ A}$$

$$Z_A = \frac{\%Z_A \times E_A}{100 \times I_A} = \frac{3 \times 500}{100 \times 2083} = 0.0072 \Omega$$

$$Z_B = \frac{5 \times 510}{100 \times 1042} = 0.0245 \Omega$$

$$I_c = \frac{E_B - E_A}{Z_A + Z_B} = \frac{510 - 500}{(0.0072 + 0.0245)} = 315.4 \text{ A}$$

**Note.** Since the value of  $X/R$  is the same for the two transformers, there is no phase difference between  $E_A$  and  $E_B$ .

**Example 32.109.** Two transformers A and B of ratings 500 kVA and 250 kVA are supplying a load kVA of 750 at 0.8 power factor lagging. Their open-circuit voltages are 405V and 415 V respectively. Transformer A has 1% resistance and 5% reactance and transformer B has 1.5% resistance and 4% reactance. Find (a) cross-current in the secondaries on no-load and (b) the load shared by each transformer.

\* Though it is chosen arbitrarily, its value must be less than either of the two no-load e.m.fs.

**Solution.** As said earlier, it is more convenient to work with ohmic impedances and for that purpose, we will convert percentage value into numerical values by assuming 400 volt as the terminal voltage (this value is arbitrary but this assumption will not introduce appreciable error).

$$\text{Now } I_{AA} R_{AA} = 1\% \text{ of } 400 \quad \therefore R_{AA} = \frac{1}{100} \times \frac{400}{1250} = 0.0032 \Omega$$

where

$$I_A = 500,000/400 = 1250 \text{ A}$$

$$I_{AA} X_{AA} = 5\% \text{ of } 400; X_{AA} = \frac{5}{100} \times \frac{400}{1250} = 0.016 \Omega \text{ (i.e. } X = 5R \text{)}$$

In a similar way, we can find  $R_B$  and  $X_B$ ;  $R_B = 0.0096 \Omega$ ;  $X_B = 0.0256 \Omega$

$$\therefore Z_A = 0.0032 + j 0.016 = 0.0163 \angle 78.5^\circ; Z_B = 0.0096 + j 0.0256 = 0.0275 \angle 69.4^\circ$$

$$Z_A + Z_B = 0.0128 + j 0.0416 = 0.0436 \angle 72.9^\circ$$

Next step is to calculate load impedance. Let  $Z_L$  be the load impedance and  $V_2$  the terminal voltage which has been assumed as 400 V.

$$\therefore (V_2^2/Z_L) = 750 \angle -36.9^\circ$$

$$\therefore Z_L = 400^2 / 750 \angle -36.9^\circ = 0.214 \angle 36.9^\circ = (0.171 + j 0.128) \Omega$$

$$(a) \quad I_C = \frac{E_A - E_B}{Z_A + Z_B} = \frac{(405 - 415)}{0.0436 \angle 72.9^\circ} = -230 \angle -72.9^\circ$$

$$(b) \quad I_A = \frac{405 \times 0.0275 \angle 69.4^\circ + (405 - 415) \times 0.214 \angle 36.9^\circ}{0.0163 \angle 78.5^\circ \times 0.0275 \angle 69.4^\circ + 0.214 \angle 36.9^\circ \times 0.0436 \angle 72.9^\circ}$$

$$= 970 \angle -35^\circ$$

$$\text{Similarly, } I_B = \frac{415 \times 0.0163 \angle 78.5^\circ - (405 - 415) \times 0.214 \angle 36.9^\circ}{0.0163 \angle 78.5^\circ \times 0.0275 \angle 69.4^\circ + 0.214 \angle 36.9^\circ \times 0.0436 \angle 72.9^\circ}$$

$$\therefore S_A = 400 \times 970 \times 10^{-3} \angle -35^\circ = 388 \angle -35^\circ \text{ kVA}; \cos \phi_A = \cos 35^\circ = 0.82 \text{ (lag)}$$

$$S_B = 400 \times 875 \times 10^{-3} \angle 42.6^\circ = 350 \angle -42.6^\circ \text{ kVA}$$

$$\cos \phi_B = \cos 42.6^\circ = 0.736 \text{ (lag)}$$

**Example 32.110.** Two transformers A and B are connected in parallel to a load of  $(2 + j 1.5)$  ohms. Their impedances in secondary terms are  $Z_A = (0.15 + j 0.5)$  ohm and  $Z_B = (0.1 + j 0.6)$  ohm. Their no-load terminal voltages are  $E_A = 207 \angle 0^\circ$  volt and  $E_B = 205 \angle 0^\circ$  volt. Find the power output and power factor of each transformer. (Elect. Machines-I, Punjab Univ. 1991)

**Solution.** Using the equations derived in Art. 30.34 (c), we have

$$I_A = \frac{E_A Z_B + (E_A - E_B) Z_L}{Z_A Z_B + Z_L (Z_A + Z_B)}$$

$$Z_A = (0.15 + j 0.5) \Omega; Z_B = (0.1 + j 0.6) \Omega; Z_L = (2 + j 1.5) = 2.5 \angle 36.9^\circ$$

$$\therefore I_A = \frac{207(0.1 + j 0.6) + (207 - 205)(2 + j 1.5)}{(0.15 + j 0.5)(0.1 + j 0.6) + (2 + j 1.5)(0.25 + j 1.1)}$$

$$= \frac{24.7 + j 127.2}{-1.435 + j 2.715} = \frac{129.7 \angle 79^\circ}{3.07 \angle 117.9^\circ} = 42.26 \angle -38.9^\circ \text{ A} = (32.89 - j 26.55) \text{ A}$$

$$I_B = \frac{E_B Z_A - (E_A - E_B) Z_L}{Z_A Z_B + Z_L (Z_A + Z_B)} = \frac{205(0.15 + j 0.5) - 2(2 + j 1.5)}{-1.435 + j 2.715} = \frac{103 \angle 75^\circ}{3.07 \angle 117.9^\circ}$$

$$= 33.56 \angle -42.9^\circ = (24.58 - j 22.84) \text{ A}$$

$$\text{Now } V_2' = I Z_L = (I_A + I_B) Z_L$$

$$= (57.47 - j 49.39)(2 + j 1.5) = 189 - j 12.58 = 189.4 \angle -3.9^\circ$$

p.f. angle of transformer  $A = -3.9^\circ - (-38.9^\circ) = 35^\circ$

$\therefore$  p.f. of  $A = \cos 35^\circ = 0.818$  (lag); p.f. of  $B = \cos [-3.9^\circ - (-42.9^\circ)] = 0.776$  (lag)

Power output of transformer  $A$  is  $P_A = 189.4 \times 42.26 \times 0.818 = 6,548 \text{ W}$

Similarly,  $P_B = 189.4 \times 33.56 \times 0.776 = 4,900 \text{ W}$

**Example 32.111.** Two transformers have the following particulars :

	Transformer A	Transformer B
Rated current	200 A	600 A
Per unit resistance 0.02	0.025	
Per unit reactance	0.05	0.06
No-load e.m.f.	245 V	240 V

Calculate the terminal voltage when they are connected in parallel and supply a load impedance of  $(0.25 + j 0.1) \Omega$ . (Elect. Machines-I, Sd. Patel Univ. 1981)

**Solution.** Impedance in ohms =  $Z_{pu} \times \text{N.L. e.m.f./full-load current}$

$$Z_A = (245/200)(0.02 + j 0.05) = 0.0245 + j 0.0613 \Omega = 0.066 \angle 68.2^\circ$$

$$Z_B = (240/600)(0.025 + j 0.06) = 0.01 + j 0.024 \Omega = 0.026 \angle 67.3^\circ$$

$$Z = (0.25 + j 0.1) = 0.269 \angle 21.8^\circ; Z_A + Z_B = 0.0345 + j 0.0853 = 0.092 \angle 68^\circ$$

$$Z_L(Z_A + Z_B) = 0.269 \times 0.092 \angle 89.8^\circ = 0.0247 \angle 89.8^\circ = (0 + j 0.0247)$$

$$Z_A Z_B = 0.066 \times 0.026 \angle 135.5^\circ = (-0.001225 + j 0.001201)$$

$$\therefore Z_A Z_B + Z_L(Z_A + Z_B) = (-0.001225 + j 0.259) = 0.0259 \angle 92.7^\circ$$

Let us take  $E_A$  as reference quantity.

Also  $E_b$  is in phase with  $E_A$  because transformers are in parallel on both sides.

$$E_A Z_B = 245(0.01 + j 0.0245) = 2.45 + j 5.87$$

$$E_B Z_A = 240(0.0245 + j 0.0613) = 5.88 + j 14.7$$

$$E_A Z_B + E_B Z_A = 8.33 + j 20.57 = 22.15 \angle 67.9^\circ$$

$$\text{Now, } I = \frac{E_A Z_B + E_B Z_A}{Z_A Z_B + Z_L(Z_A + Z_B)} = \frac{22.15 \angle 67.9^\circ}{0.0259 \angle 92.7^\circ} = 855 \angle -24.8^\circ$$

$$\therefore V_2 = I Z_L = 885 \angle -24.8^\circ \times 0.269 \angle 21.8^\circ = 230 - 3^\circ$$

### Tutorial Problems 29.1

1. A 1000-kVA and a 500-kVA, 1-phase transformers are connected to the same bus-bars on the primary side. The secondary e.m.fs. at no-load are 500 and 510 V respectively. The impedance voltage of the first transformer is 3.4% and of the second 5%. What cross-current will pass between them when the secondaries are connected together in parallel? Assuming that the ratio of resistance to reactance is the same in each, what currents will flow in the windings of the two transformers when supplying a total load of 1200 kVA.

[(i) 290 A (ii) 1577 and 900 A] (City & Guilds, London)

2. Two transformers  $A$  and  $B$  are connected in parallel to supply a load having an impedance of  $(2 + j 1.5\Omega)$ . The equivalent impedances referred to the secondary windings are  $0.15 + j 0.5 \Omega$  and  $0.1 + j 0.6 \Omega$  respectively. The open-circuit e.m.f. of  $A$  is 207 V and of  $B$  is 205 V. Calculate (i) the voltage at the load (ii) the power supplied to the load (iii) the power output of each transformer and (iv) the kVA input to each transformer.

[(i) 189  $\angle$  -3.8°V (ii) 11.5 kW (iii) 6.5 kW, 4.95 kW (iv) 8.7 kVA, 6.87 kVA]

## QUESTIONS AND ANSWERS ON TRANSFORMERS

**How is magnetic leakage reduced to a minimum in commercial transformers ?**

**Ans.** By interleaving the primary and secondary windings.

**Mention the factors on which hysteresis loss depends ?**

**Ans.** (i) Quality and amount of iron in the core (ii) Flux density and (iii) Frequency.

**How can eddy current loss be minimised ?**

**Ans.** By laminating the core.

**In practice, what determines the thickness of the laminae or stampings ?**

**Ans.** Frequency.

**Does the transformer draw any current when its secondary is open ?**

**Ans.** Yes, no-load primary current.

**Why ?**

**Ans.** For supplying no-load iron and copper losses in primary.

**Is Cu loss affected by power factor ?**

**Ans.** Yes, Cu loss varies inversely with power factor.

**Why ?**

**Ans.** Cu loss depends on current in the primary and secondary windings. It is well-known that current required is higher when power factor is lower.

**What effects are produced by change in voltage ?**

**Ans.** 1. Iron loss. varies approximately as  $V^2$ .

2. Cu loss..... it also varies as  $V^2$  but decreases with an increase in voltage *if constant kVA output is assumed.*

3. Efficiency ..... for distribution transformers, efficiency at fractional loads decreases with increase in voltage while at full load or overload it increases with increase in voltage and *vice-versa.*

4. Regulation. ....it varies as  $V^2$  but decreases with increase in voltage *if constant kVA output is assumed.*

5. Heating. for constant kVA output, iron temperatures increase whereas Cu temperatures decrease with increase in voltages and *vice-versa.*

**Q. 10. How does change in frequency affect the operation of a given transformer ?**

**Ans.** 1. Iron loss increases with a decrease in frequency. A 60-Hz transformer will have nearly 11% higher losses when worked on 50Hz instead of 60 Hz. However, when a 25-Hz transformer is worked on 60 Hz, iron losses are reduced by 25%.

2. Cu loss. in distribution transformers, it is independent of frequency.

3. Efficiency since Cu loss is unaffected by change in frequency, a given transformer efficiency is less at a lower frequency than at a higher one.

4. Regulation. regulation at unity power factor is not affected because  $IR$  drop is independent of frequency. Since reactive drop is affected, regulation at low power factors decreases with a decrease in frequency and *vice-versa.* For example, the regulation of a 25-Hz transformer when operated at 50-Hz and low power factor is much poorer.

5. Heating. since total loss is greater at a lower frequency, the temperature is increased with decrease in frequency.

## OBJECTIVE TESTS – 32

1. A transformer transforms
  - (a) frequency
  - (b) voltage
  - (c) current
  - (d) voltage and current.
2. Which of the following is not a basic element of a transformer ?
  - (a) core
  - (b) primary winding
  - (c) secondary winding
  - (d) mutual flux.
3. In an ideal transformer,
  - (a) windings have no resistance
  - (b) core has no losses
  - (c) core has infinite permeability
  - (d) all of the above.
4. The main purpose of using core in a transformer is to
  - (a) decrease iron losses
  - (b) prevent eddy current loss
  - (c) eliminate magnetic hysteresis
  - (d) decrease reluctance of the common magnetic circuit.
5. Transformer cores are laminated in order to
  - (a) simplify its construction
  - (b) minimise eddy current loss
  - (c) reduce cost
  - (d) reduce hysteresis loss.
6. A transformer having 1000 primary turns is connected to a 250-V a.c. supply. For a secondary voltage of 400 V, the number of secondary turns should be
 

(a) 1600	(b) 250
(c) 400	(d) 1250
7. The primary and secondary induced e.m.fs.  $E_1$  and  $E_2$  in a two-winding transformer are **always**
  - (a) equal in magnitude
  - (b) antiphase with each other
  - (c) in-phase with each other
  - (d) determined by load on transformer secondary.
8. A step-up transformer increases
 

(a) voltage	(b) current
(c) power	(d) frequency.
9. The primary and secondary windings of an ordinary 2-winding transformer **always** have
  - (a) different number of turns
  - (b) same size of copper wire
  - (c) a common magnetic circuit
  - (d) separate magnetic circuits.
10. In a transformer, the leakage flux of each winding is proportional to the current in that winding because
  - (a) Ohm's law applies to magnetic circuits
  - (b) leakage paths do not saturate
  - (c) the two windings are electrically isolated
  - (d) mutual flux is confined to the core.
11. In a two-winding transformer, the e.m.f. per turn in secondary winding is **always** ..... the induced e.m.f. per turn in primary.
  - (a) equal to  $K$  times
  - (b) equal to  $1/K$  times
  - (c) equal to
  - (d) greater than.
12. In relation to a transformer, the ratio 20 : 1 indicates that
  - (a) there are 20 turns on primary one turn on secondary
  - (b) secondary voltage is  $1/20$ th of primary voltage
  - (c) primary current is 20 times greater than the secondary current.
  - (d) for every 20 turns on primary, there is one turn on secondary.
13. In performing the short circuit test of a transformer
  - (a) high voltage side is usually short circuited
  - (b) low voltage side is usually short circuited
  - (c) any side is short circuited with preference
  - (d) none of the above.

*(Elect. Machines, A.M.I.E. Sec. B, 1993)*
14. The equivalent resistance of the primary of a transformer having  $K = 5$  and  $R_1 = 0.1$  ohm when referred to secondary becomes. ohm.
  - (a) 0.5
  - (b) 0.02
  - (c) 0.004
  - (d) 2.5
15. A transformer has negative voltage regulation when its load power factor is
  - (a) zero
  - (b) unity
  - (c) leading
  - (d) lagging.

16. The primary reason why open-circuit test is performed on the low-voltage winding of the transformer is that it
- draws sufficiently large on-load current for convenient reading
  - requires least voltage to perform the test
  - needs minimum power input
  - involves less core loss.
17. No-load test on a transformer is carried out to determine
- copper loss
  - magnetising current
  - magnetising current and no-load loss
  - efficiency of the transformer.
18. The main purpose of performing open-circuit test on a transformer is to measure its
- Cu loss
  - core loss
  - total loss
  - insulation resistance.
19. During short-circuit test, the iron loss of a transformer is negligible because
- the entire input is just sufficient to meet Cu losses only
  - flux produced is a small fraction of the normal flux
  - iron core becomes fully saturated
  - supply frequency is held constant.
20. The iron loss of a transformer at 400 Hz is 10 W. Assuming that eddy current and hysteresis losses vary as the square of flux density, the iron loss of the transformer at rated voltage but at 50 Hz would be. watt.
- 80
  - 640
  - 1.25
  - 100
21. In operating a 400 Hz transformer at 50 Hz
- only voltage is reduced in the same proportion as the frequency
  - only kVA rating is reduced in the same proportion as the frequency
  - both voltage and kVA rating are reduced in the same proportion as the frequency
  - none of the above.
22. The voltage applied to the h.v. side of a transformer during short-circuit test is 2% of its rated voltage. The core loss will be. percent of the rated core loss.
- 4
  - 0.4
  - 0.25
  - 0.04
23. Transformers are rated in kVA instead of kW because
- load power factor is often not known
  - kVA is fixed whereas kW depends on load p.f.
  - total transformer loss depends on volt-ampere
  - it has become customary.
24. When a 400-Hz transformer is operated at 50 Hz its kVA rating is
- reduced to 1/8
  - increased 8 times
  - unaffected
  - increased 64 times.
25. At relatively light loads, transformer efficiency is low because
- secondary output is low
  - transformer losses are high
  - fixed loss is high in proportion to the output
  - Cu loss is small.
26. A 200 kVA transformer has an iron loss of 1 kW and full-load Cu loss of 2kW. Its load kVA corresponding to maximum efficiency is kVA.
- 100
  - 141.4
  - 50
  - 200
27. If Cu loss of a transformer at 7/8th full load is 4900 W, then its full-load Cu loss would be .....watt.
- 5600
  - 6400
  - 375
  - 429
28. The ordinary efficiency of a given transformer is maximum when
- it runs at half full-load
  - it runs at full-load
  - its Cu loss equals iron loss
  - it runs slightly overload.
29. The output current corresponding to maximum efficiency for a transformer having core loss of 100 W and equivalent resistance referred to secondary of  $0.25 \Omega$  is ampere.
- 20
  - 25
  - 5
  - 400
30. The maximum efficiency of a 100-kVA transformer having iron loss of 900 kW and F.L. Cu loss of 1600 W occurs at kVA.
- 56.3
  - 133.3
  - 75
  - 177.7



31. The all-day efficiency of a transformer depends primarily on  
 (a) its copper loss  
 (b) the amount of load  
 (c) the duration of load  
 (d) both (b) and (c).
32. The marked increase in kVA capacity produced by connecting a 2 winding transformer as an autotransformer is due to  
 (a) increase in turnratio  
 (b) increase in secondary voltage  
 (c) increase in transformer efficiency  
 (d) establishment of conductive link between primary and secondary.
33. The kVA rating of an ordinary 2-winding transformer is increased when connected as an autotransformer because  
 (a) transformation ratio is increased  
 (b) secondary voltage is increased  
 (c) energy is transferred both inductively and conductivity  
 (d) secondary current is increased.
34. The saving in Cu achieved by converting a 2-winding transformer into an autotransformer is determined by  
 (a) voltage transformation ratio  
 (b) load on the secondary  
 (c) magnetic quality of core material  
 (d) size of the transformer core.
35. An autotransformer having a transformation ratio of 0.8 supplies a load of 3 kW. The power transferred conductively from primary to secondary is. kW.  
 (a) 0.6 (b) 2.4  
 (c) 1.5 (d) 0.27
36. The essential condition for parallel operation of two 1- $\phi$  transformers is that they should have the same  
 (a) polarity  
 (b) kVA rating  
 (c) voltage ratio  
 (d) percentage impedance.
37. If the impedance triangles of two transformers operating in parallel are not identical in shape and size, the two transformers will  
 (a) share the load unequally  
 (b) get heated unequally  
 (c) have a circulatory secondary current even when unloaded  
 (d) run with different power factors.
38. Two transformers *A* and *B* having equal outputs and voltage ratios but unequal percentage impedances of 4 and 2 are operating in parallel. Transformer *A* will be running over-load by ..... percent.  
 (a) 50 (b) 66  
 (c) 33 (d) 25

## ANSWERS

1. d 2. d 3. d 4. d 5. b 6. a 7. c 8. a 9. c 10. b 11. c 12. d 13. b 14. d  
 15. c 16. a 17. c 18. b 19. b 20. b 21. b 22. d 23. c 24. a 25. c 26. b 27. b 28. c 29. a 30. c  
 31. d 32. d 33. c 34. a 35. b 36. a 37. d 38. c