

CHAPTER 12

Learning Objectives

- Preference for Electricity
- Comparison of Sources of Power
- Sources for Generation of Electricity
- Brief Aspects of Electrical Energy Systems
- Utility and Consumers
- Why is the Three-phase System Most Popular?
- Cost of Generation
- Staggering of Loads during peak-demand Hours
- Classifications of Power Transmission
- Selecting A.C. Transmission Voltage for a Particular Case
- Conventional Sources of Electrical Energy
- Steam Power Stations (Coal-fired)
- Nuclear Power Stations
- Advantages of Nuclear Generation
- Disadvantages
- Hydroelectric Generation
- Non-Conventional Energy Sources
- Photo Voltaic Cells (PV Cells or SOLAR Cells)
- Fuel Cells
- Principle of Operation
- Chemical Process (with Acidic Electrolyte)
- Schematic Diagram
- Array for Large outputs
- High Lights
- Wind Power
- Background
- Basic Scheme
- Indian Scenario

INTRODUCTION TO ELECTRICAL ENERGY GENERATION



T Electricity is generated at power plants and transmitted to different substations from where it will be distributed to individual customers

Preference for Electricity

Energy is vital for all living-beings on earth. Modern life-style has further increased its importance, since a faster life means faster transport, faster communication, and faster manufacturing processes. All these lead to an increase in energy required for all those modern systems.

Arising out of comparison of status of nations, the progress is related in terms of per capita consumption of electrical energy (i.e. kWh consumed per person per year). At present, this parameter for India is about 300, for UK it is 12 to 15 times more, and for USA, it is about 30 times more.

It simply means that Electrical energy is the most popular form of energy, whether we require it in the usable thermal form (= heating applications), in mechanical form (= electrical motor-applications in Industries), for lighting purposes (= illumination systems), or for transportation systems.

Following are the main reasons for its popularity.

1. Cleaner environments for user
2. Higher efficiency
3. Better controllability
4. Easier bulk-power, long-distance transportation of power using overhead transmission or underground cables
5. Most versatile devices of energy conversions from Electrical to other forms are available for different purposes, such as thermal, illumination, mechanical, sound, chemical, etc.

Comparison of Sources of Power

While selecting a method of generating electricity, following factors are taken into account for purposes of comparison:

- (a) Initial cost: For a given rating of a unit (in the minds of planners), investment must be known. Naturally, lower the initial cost, better it is.
- (b) Running Cost:- To produce a given amount of electrical energy, the cost of conversion process (including proportional cost of maintenance/repairs of the system) has to be known.
- (c) Limitations:- Whether a particular resource is available, whether a unit size of required rating is available from a single unit or from an array of large number of units, and whether a particular method of generation is techno-economically viable and is time-proven, are typical queries related to the limitations of the concerned method.
- (d) (1) perpetuity, (2) efficiency, (3) reliability, (4) cleanliness and (5) simplicity.

It is naturally desirable that the source must have perpetuity (= be of endless duration), high conversion efficiency, and reliability (in terms of availability in appropriate quantity). The energy conversion must be through a cleaner process (specially from the view-points of toxicity, pollution or any other hazardous side effects). Further, a simpler overall system is always preferred with regards to maintenance/repairs problems and is supposed to be more reliable.

Sources for Generation of Electricity

Following types of resources are available for generating electrical energy (No doubt, this list can be extended to include some more up-coming resources. The following list, however, gives the popular and potential resources).

(a) Conventional methods

- (a) **Thermal:** Thermal energy (from fossil fuels) or Nuclear Energy used for producing steam for turbines which drive the alternators (= rotating a.c. generators).
- (b) **Hydro-electric:** Potential of water stored at higher altitudes is utilized as it is passed through water-turbines which drive the alternators.

(b) Non-conventional methods

- (c) **Wind power:** High velocities of wind (in some areas) are utilized in driving wind turbines coupled to alternators. Wind power has a main advantage of having zero production cost. The cost of the equipment and the limit of generating-unit-rating is suitable for a particular



location (= geographically) are the important constraints. This method has exclusive advantages of being pollution free and renewable. It is available in plentiful quantity, at certain places. It suffers from the disadvantages of its availability being uncertain (since dependent on nature) and the control being complex (since wind-velocity has wide range of variation, as an input, and the output required is at constant voltage and constant frequency). Single large-power units cannot be planned due to techno-economic considerations.



Use of Wind Power

- (d) **Fuel cells:** These are devices which enable direct conversion of energy, chemically, into electrical form. This is an up-coming technology and has a special merit of being pollution-free and noise-free. It is yet to become popular for bulk-power generation.
- (e) **Photo voltaic cells:** These directly convert solar energy into electrical energy through a chemical action taking place in solar cells. These operate based on the photo-voltaic effect, which develops an emf on absorption of ionizing radiation from Sun.

Power Scenario In India:-

Following approximate statistical data give an idea about some aspects in this regard.

Total installed capacity	:	150,000 MW
Hydropower	:	50,000 MW
Nuclear	:	10,000 MW
Thermal (fossil fuels)	:	80,000 MW
Other methods	:	10,000 MW

Other methods include partly exploited Potential such as Wind, Solar, Co-generation, Methods using Bio-fuels, etc.

Brief Aspects of Electrical Energy Systems

Utility and Consumers

At generating stations, power is generated at the best locations. Load-centres are generally away from these. Generation-units and Loads are connected by transmission systems. Thus, the energy system is divided into two main parts.

- Utility (including sources and transmission network) and,
- Consumers (who utilize the electrical energy)

Why is the three- phase a. c. system most popular?

- It is well known that a.c. generation is simpler (than d.c. generation through electrical machines because of absence of commutators in a.c. machines). Further, mechanical commutation system in d.c. machines sets an upper limit of their size, while the rating of the individual generators in *modern power stations* is too large, say about 1500 times the rating of a single largest feasible d.c. machine. A.C. further facilitates in stepping down or stepping-up of a voltage to suit a particular requirement, with the help of a simple device, the well-known transformer.
- Changing over from a.c. to d.c. is very easy these days due to the rectifiers of sufficiently high power ratings, so that a wide range of d.c. – applications can now be catered to.
- As the number of phases goes on increasing the power-output (from a device using a given quantity of active material, namely, that used for core and for winding) increases, but the number of circuits (*i.e.* connecting lines/ wires, switches, etc) also increases. These two points are contradictory. A choice will be in favour of such a number (of phases) which will be high enough from power-output point of view but low enough from viewpoints

of complexity of connecting/controlling large number of phases. There is a Golden compromise. It has resulted into popularity of the three-phase a. c. systems over the entire time period. Now it has almost become a standard practice for all purposes.

Cost of Generation

Cost of generation for one unit of electrical energy depends on the method of generation, formulae worked to assess its running cost under the specified conditions, and the cost of transmission line loss to transport power upto the load. These days, a modern utility (= electricity board) has a large number of generators sharing the responsibility of supplying power to all the customers connected to the Grid (= common supply-network). Then, for an increase in load-demand, at a known location, the most economical generating unit is to be identified and that unit should be monitored to meet the increased demand.

Staggering of Loads during Peak-demand Hours

Incentives to consumers (by way of supplying at reduced rates during light load hours e.g. Late night 'hours, after noon hours) help in even demand throughout the day.

Classifications of Power Transmission

- (a) Using underground cables or using overhead transmission lines.
- (b) Extra High Voltage A.C.-versus-Extra High Voltage D.C. transmission systems.

Selecting A.C. Transmission Voltage for a Particular Case

In general, for transporting a given power of $V I$ watts, either V can be high or V can be low. Accordingly, the current can be either low or high respectively. Higher voltage means higher cost of insulation, and larger clearances. Higher current means larger cross section of conductors. Considering these together, the most economical voltage has to be found out for a particular requirement.

Kelvin's Laws give a guideline for this. (These are discussed in Art. 47.21 in Vol. III, of this book).

Conventional Sources of Electrical Energy

Thermal (coal, gas, nuclear) and hydro-generations are the main conventional methods of generation of Electrical Energy. These enjoy the advantages of reaching perfections in technologies for these processes. Further, single units rated at large power-outputs can be manufactured along with main components, auxiliaries and switch-gear due to vast experiences during the past century. These are efficient and economical.

These suffer from the disadvantages listed below:

1. The fuels are likely to be depleted in near future, forcing us to conserve them and find alternative resources.
2. Toxic, hazardous fumes and residues pollute the environment.
3. Overall conversion efficiency is poor.
4. Generally, these are located at remote places with respect to main load centres, increasing the transmission costs and reducing the system efficiency.
5. Maintenance costs are high.

Out of these, only two such types will be dealt here, which have a steam turbine working as the prime mover. While remaining two use Internal Combustion Engines (I.C. engines) or Gas turbine as the prime mover, and these will *not* be dealt with, in this Introductory treatment.

The steam-turbine driven systems are briefly discussed below.

Steam Power Stations (Coal-fired)

India has rich stocks of coal as a natural resource. Chemical energy stored within the coal is finally transformed into Electrical energy through the process of these stations. Heat released by the combustion of coal produces steam in a boiler at elevated temperatures and pressures. It is then passed through steam turbines, which drive the alternator, the output of which is the electrical energy.

Figure 24.1 shows a simple schematic diagram of a modern coal-fired thermal station.

In India, coal is generally of low grade containing ash upto 40 %. It poses two problems.

(i) Calorific value is low and hence system efficiency can be increased only by additional processes like pulverizing the coal and using oil firing to start with, (ii) large volumes of ash have to be handled after ensuring that ash is extracted to the maximum possible extent (upto 99 %) by using electrostatic precipitators, before flue gases from boiler are finally passed on to the atmosphere.

Coal is burnt in the boiler. This heat converts water into steam when passed through the boiler tubes. Modern plants have super heaters to raise the temperature and pressure of steam so that plant efficiency is increased. Condenser and cooling tower deal with steam coming out of turbine. Here, maximum heat is extracted from steam (which then takes the form of water) to pre-heat the incoming water and also to recycle the water for its best utilization.

Steam-turbine receives controlled steam from boiler and converts its energy into mechanical energy which drives the 3-ph a. c. generator (=alternator). The alternator delivers electrical energy, at its rated voltage (which may be between 11 to 30 kV). Through a circuit breaker, the step up transformer is supplied. Considering the bulk-power to be transmitted over long distances, the secondary rating

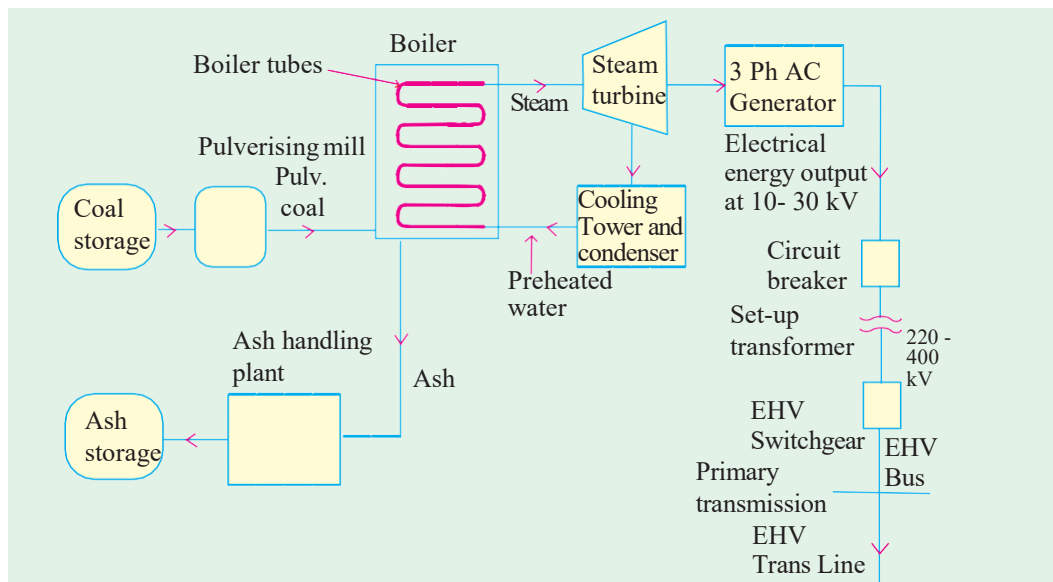

Fig. 24.1. Schematic Diagram of a Coal-fired Thermal Station

of this transformer may be 220 or 400 kV (as per figures for India). Through Extra-High Voltage Switch gear, the Bus is energized and the EHV primary transmission line can transport power to the Load centres connected to it.

A modern coal-fired thermal power station consumes about 10 % of its power for supplying to the Auxiliaries. These are mainly as follows.

- (a) Main-exciter for alternator.
- (b) Water pumps.
- (c) Fans: Forced draught and Induced draught fans for Pre-heaters and Chimney.
- (d) Coal handling plant including pulverising mill.
- (e) Ash handling plant including Electrolytic Precipitator.

Naturally, whenever such a station is to be brought into operation (either at commissioning or after repairs/maintenance schedule) the power required for the auxiliaries has to be supplied by the grid. Once the system is energized fully, it will look after supplying power to its own auxiliaries.

Merits of Coal-fired thermal stations

1. Fuel (=coal) is cheap.
2. Less initial cost is required.
3. It requires less space.
4. As a combination of all above points, the cost of generating unit of electrical energy is less.

Demerits

1. Atmospheric pollution is considerable.
2. Coal may have to be transported over long distances, in some cases, after some years, and then the energy cost may be quite high.

Nuclear Power Stations

Nuclear energy is available as a result of fission reaction. In a typical system, Uranium 235 is bombarded with neutrons and Heat energy is released. In chain-reaction, these release more neutrons, since more Uranium 235 atoms are fissioned. Speeds of Neutrons must be reduced to critical speeds for the chain reaction to take place. Moderators (= speed-reducing agents like graphite, heavy water, etc). are used for this purpose. Nuclear fuel rods (of Uranium 235) must be embedded in speed-reducing agents. Further, control rods (made of cadmium) are required since they are strong neutron-absorbers and help in finely regulating this reaction so that power control of the generator is precisely obtainable. When control rods are pulled out and are away from fuel rods, intensity of chain reaction increases, which increases the power output of the system. While if they are pushed in and closer to the fuel rods, the power-output decreases. Thus, the electrical load demand on the generator decides (automatically) the control-rod positions through a very sophisticated control system.

Fig. 24.2 shows a basic scheme of such a Nuclear power-station.

Advantages of Nuclear Generation

1. Quantity of fuel required is small for generating a given amount of electrical energy, compared to that with other fuels.
2. It is more reliable, cheaper for running cost, and is efficient when operated at rated capacity.

Disadvantages

1. Fuel is expensive and not abundantly available everywhere.
2. It has high capital cost.
3. Maintenance charges are high.
4. Nuclear waste disposal is a problem.

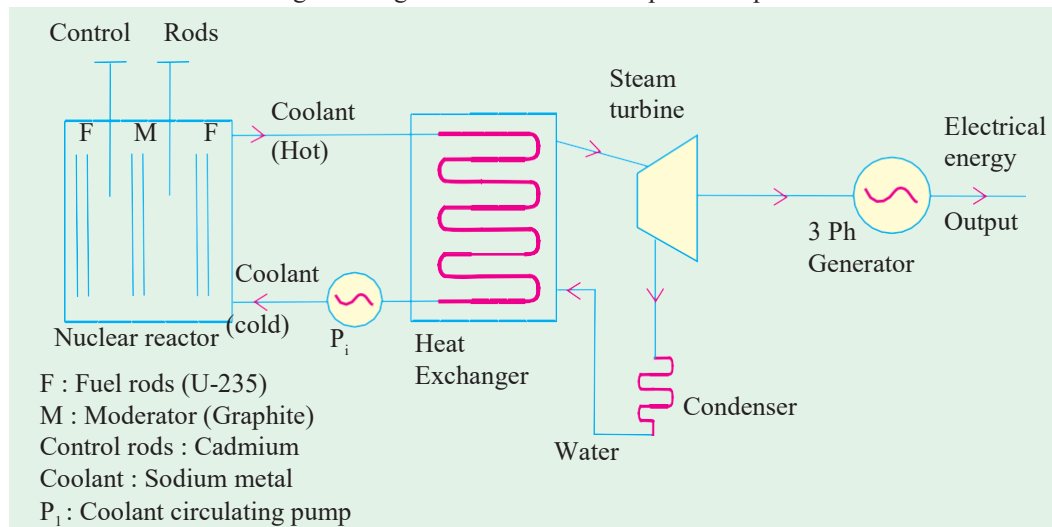

Fig. 24.2. Schematic Diagram of a Nuclear Power Station indicating Main Components

Hydroelectric Generation

Water-reservoir at higher altitudes is a pre-requisite for this purpose. Power-house is located at a lower level. The difference in these two levels is known as “Head.”

Based on the “Heads”, the Hydroelectric stations are categorized below:

1. Low head up to 60 metres.
2. Medium head between 60 and 300 metres.
3. High heads above 300 metres.

In this method of generation, water from higher height is passed through penstock as controlled in the valve-house, into the water turbine. Thus, potential energy of water stored at higher altitudes is first converted into Kinetic energy. As the water reaches the turbine, it gains speed after losing the Potential energy. Kinetic energy of this speedy water drives the water turbine, which converts this into mechanical output. It drives the coupled generator, which gives Electrical energy output.

A schematic diagram of such a system is shown in fig.

The valve house has a controlling valve (=main sluice valve) and a protecting valve (= an automatic, isolating, “butterfly” type valve). As is obvious, power control is done by the main sluice valve, while “butterfly” valve comes into action if water flows in opposite direction as a result of a sudden drop in load on the generator. Otherwise, the penstock is subjected to extreme strains and it has a tendency to burst due to pressure of water as a result of sudden load reduction.

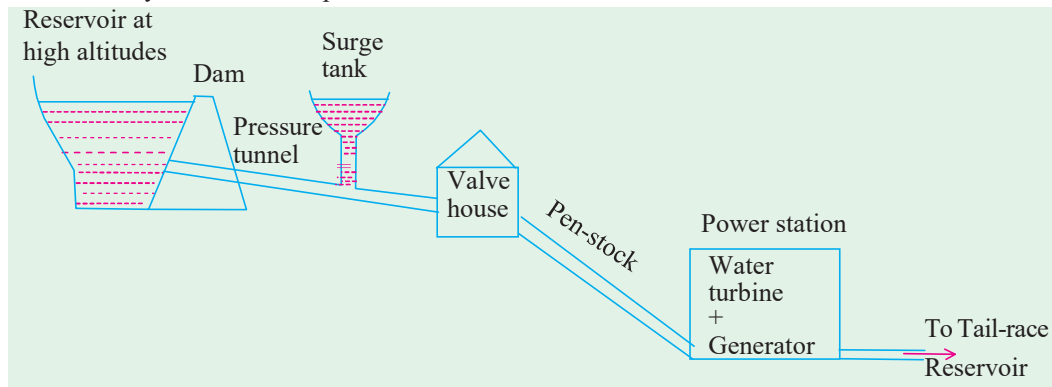

Fig. 24.3. Schematic of a typical Hydroelectric station

Note: Variation of Head (low-, medium-, or high-head) will affect the block-schematic

After doing the work (of imparting its energy to the water turbine), the water is allowed to pass into the tail-race reservoir.

The water turbines are essentially low-speed prime movers. In that, the best operating speed is dependent on the head. Alternators coupled to water turbines thus have large number of poles (since $P = 120 f/N$). Such alternators have the Salient-Pole type rotor.

There are different types of water turbines suitable for different cases (i.e. Heads, Power rating, Load-variation curve, etc). Since, this is only an elementary treatment, these aspects will not be discussed here.

Non-Conventional Energy Sources

Considering the previously discussed thermal methods of conventional energy-generations, it is necessary to understand the non-conventional energy sources, since they have two points in their favour.

- (a) Non-polluting processes are used.
- (b) Perpetuity and renewability of the main source (which is a natural atmospheric resource) generally exists.

The non-conventional energy sources are further advantageous due to virtually zero running cost, since wind energy or solar energy is the input-source of power.

However, they are disadvantageous due to high initial cost (per MW of installed capacity) and due to uncertainty resulting out of weather changes. For example, dense clouds (or night hours) lead to non-availability of solar energy. Similarly, “still-air” condition means no possibility of wind power generation, and during stormy weathers, wind turbines cannot be kept in operation (due to dangerously high speeds they would attain if kept in operation).

Photo Voltaic Cells (P.V. Cells or SOLAR Cells)

When ionized solar radiation is incident on a semi-conductor diode, energy conversion can take place with a voltage of 0.5 to 1 volt (d.c.) and a current density of 20-40 mA/cm², depending on the

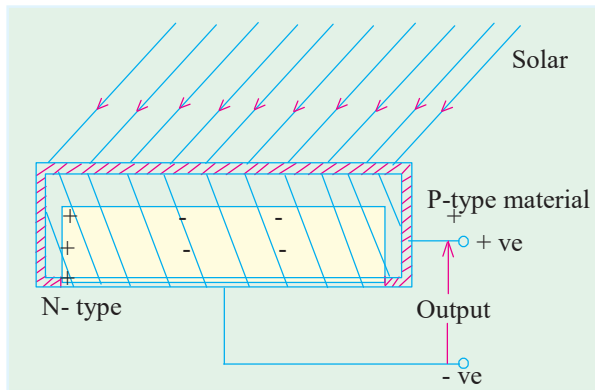

Fig. 24.4. Photo Voltaic (or Solar Cell)

materials used and the conditions of Sunlight. Area of these solar cells decides the current output. An array of large number of such diodes (i.e. Solar cells) results into higher d.c. output voltage.

Since, the final form of electrical energy required is generally an alternating current, it is realized from d.c. using inverters.

At quite a few locations in India, for realizing few hundred kilowatts of power-rating, huge arrays are accommodated in horizontal as well as vertical stacks, so that land area required is not too vast. Electrically, they are connected in series and in parallel

combinations of cells so that rated voltage and current are realized.

Just to understand the principle of operation of solar cells, let a semi-conductor diode receive ionized radiation from Sun, as in fig. 24.4.

Typical materials used for these cells are: material doped with boron, cadmium sulphide, gallium-arsenide, etc. Their choice is mainly decided by conversion efficiency. Best material may lead to the efficiency being typically 15%. Since solar energy is available free of cost, this low-efficiency does not matter.

This method suffers from the disadvantages of having high initial cost and uncertainty (since dependent on weather conditions) including non operative night periods. Main advantages are: (i) no running cost (however, replacements of components may be a botheration), (ii) no pollution, (iii) location can be near the load (hence transportation of power is not required over long distances), (iv) since natural source is involved, it is perpetual.

Individual stations using solar cells are in operation with ratings of the order of 250-1000 kW. With manufacturing costs of semi-conductor devices going down and with the advent of better and better quality of cells which will be available in future, this method of generation has bright prospects.

Fuel Cells

Principle of Operation

In Fuel cells, negative porous electrode is fed by hydrogen and the positive porous electrode is fed by oxygen. Both the electrodes are immersed in an electrolyte. The porous electrodes are made of such a conducting material that both the fuel (oxygen and hydrogen) and the electrolyte can pass through them. Such a material for electrodes is nickel. The electrolyte is a solution of sulphuric acid or potassium hydroxide. The electrodes have a catalyst (= platinum or sintered nickel) which break the fuel compound into more reactive atoms.

Chemical Process (with Acidic Electrolyte)



These hydrogen ions enter the solution (=electrolyte) leaving behind electrons which pass through external circuit to the positive electrode.

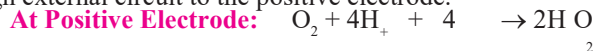

Thus, the combination of Hydrogen and Oxygen results into water at the positive electrode. Water is the waste-product of the cell, which is harmless. The process is, thus, pollution free. There is no source of energy required, since the process is basically “chemical” in nature.

Schematic Diagram. It is given in fig 24.5

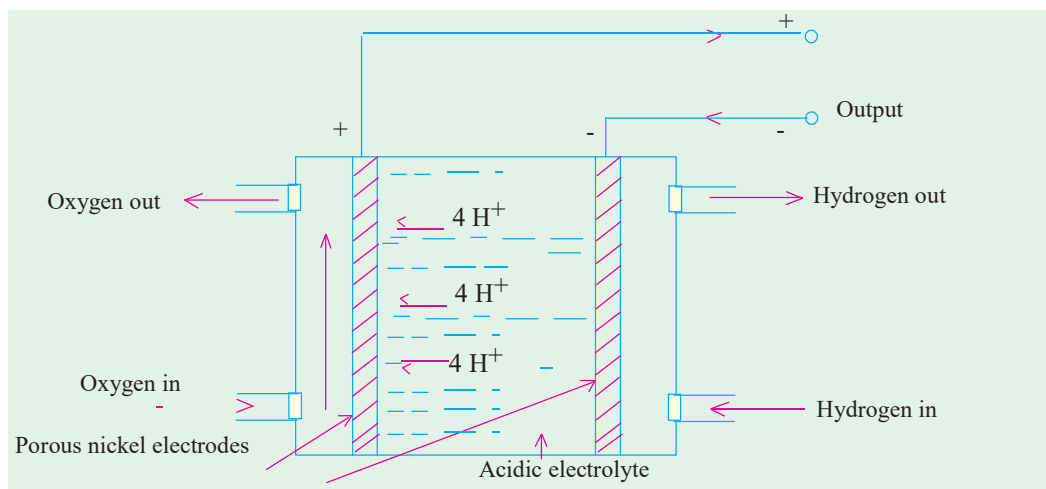

Fig. 24.5. Fuel Cell

Array for Large outputs

A fuel cell has a d. c. output voltage typically of 1.23 volts at normal atmospheric pressure and temperature. Raising pressure and temperature increases this voltage. To realize large output parameters (= voltage, current, and hence power), an array of a large number of fuel cells (connected in series as well as in parallel) is made. Voltage levels of 100 to 1000 V and power levels in kilowatts can be realized.

High Lights

1. Pollution-free, noiseless.
2. No outside source of energy is required.
3. Efficient.
4. No restriction on location
 - (a) High initial cost.
 - (b) Working life is short.

Note: Solar energy can also be used for generating electrical energy through an intermediate stage of producing steam, which is used later for driving an alternator. However, this method is not discussed here.

Wind Power

Background

Wind power has been in use for serving the mankind, since centuries through what has been popularly known as “Wind-mills.” There is no “electrical” stage of energy in old-styled uses where wind-velocity is directly used for performing the jobs such as wheat-grinding, pumping water for irrigation, sailing vessels, etc. It enjoys the advantages of being plentiful, inexhaustible, renewable and non-polluting, over and above being cheap for running costs. It suffers from disadvantages of being unreliable, and being economically un-viable for large power generation. In India, a large number of such units with small and medium power ratings (up to 100 kW) are already in operation mainly in coastal or hilly areas. With the modern system, it is now preferred to have suitable power-control circuits on the output side of wind-generators so that these can pump energy into low voltage lines of the grid over a wide range of variation of wind speeds.

Basic Scheme

A large variety of wind-turbines naturally exist arising out of large variation in wind-pattern

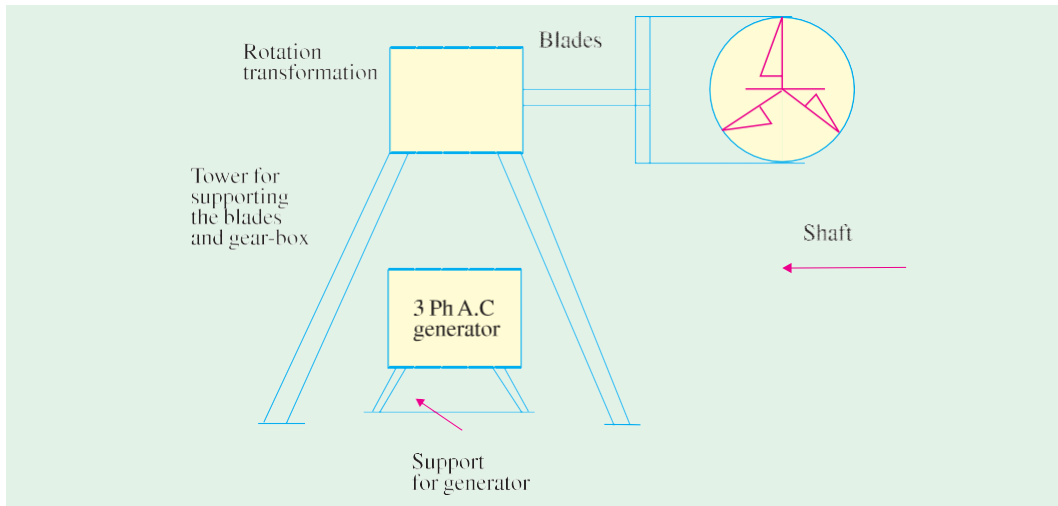

Fig. 24.6 (a) . Wind-generation, a Schematic view

Fig. 24.6 (b). Part-side-view to show a typical three bladed wind turbine

all over and out of different manufacturers producing systems with different designs. Since the aim here is to understand the basic system, only one type of system is presented here.

In Fig. 24.6 (a) an arrangement wherein, a horizontal three-bladed system is shown mounted on a tower. Through rotation-transformation using gears to step up the speed and to link the horizontal axis of turbine with vertical axis of generator.

The speed of wind varies, as such turbine speed also varies so that output frequency and voltage of three-phase alternator vary over a wide range. Further, its waveform is also a distorted one. To increase its utility, it is necessary to modulate (through proper power-control) to derive line-frequency constant voltage output and hook-up to local grid for pumping the available wind-energy into it. This is schematically represented in fig 24.7.

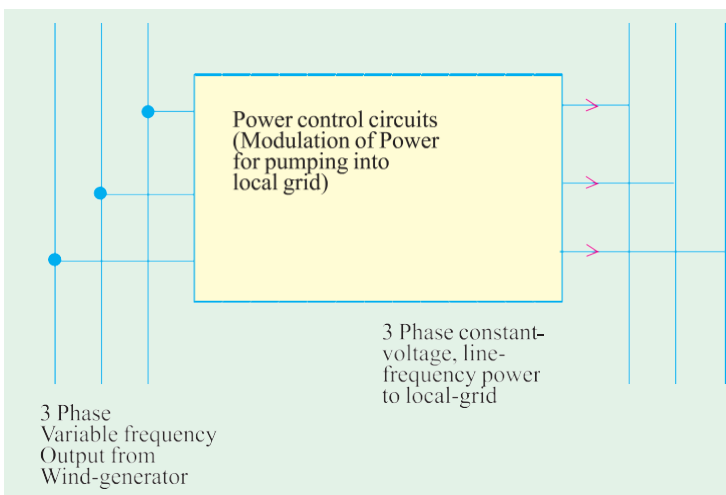

Fig. 24.7

Indian Scenario

Wind farms have been located where a large number of wind generators of ratings of few hundred kilowatts are in operation. For every unit, there is a safe wind - speed zone. If the wind-speed is below this, there is no appreciable power output, hence, it is better that the system is *not* brought into operation. If the wind speeds are too high, it is mechanically unsafe and hence it is *not* to be operated, even if the energy available is higher. This is decided by automated system. Such farms are located in coastal regions and in hilly areas. Because of the metering of energy received by the local grid, the investor can get a good return through payment from the grid-authorities. Hence, this has become a medium-level and attractive industrial investment.