

Safety Features of ICF and LHB coaches

Indian Railways is the lifeline of transportation in India. Post Independence Indian Railway tied up with Swiss-car and Elevator -company

Independence Indian

“Transfer of technology” with Swiss-car and Elevator -company to manufacture steel bodied passenger coaches.

Integral Coach Factory was established at Perambur, -Chennai.

These coaches are termed as ICF coaches.

Maximum tare weight 50 Tonnes.

Maximum speed potential 140 Kmph.



Due to the need for new technology" state of art coach technology" as procured from Alstom LHB of Germany in 2000.

Rail coach factory (RCF) started manufacturing these LHB coaches from 2001 and the first indigenous LHB coach was rolled out in Dec 2002.

LHB coaches are light weight and made from Low corrosive steels.

The modular construction, integration of lights into interior ceilings, fire retardant materials, sound insulation, wide window glasses etc. are the characteristic design features with respect to safety and passenger comfort.

LHB bogies have Cartridge type roller bearing which are more reliable and needs lesser maintenance.

Rigid joint exist between ICF bogie frame and the axle, whereas in LHB bogie the joint is articulated by a control arm.

Safety features

The coach design includes safety features to ensure reduced impact on the passengers during untoward accidents.

The design features include the coach body and the coach interiors.

The various safety features are as follows-

1. Anti telescopic construction
2. Crumple zones
3. Fire retardant materials
4. Emergency windows
5. Couplers
6. Injury free interior features
7. Bogie design
8. Brakes
9. Passenger Emergency Pull device
10. Brake accelerator (in LHB coaches)
11. Wheel slide protection system (in LHB coaches)
12. Earthing equipment in LHB coaches (in LHB coaches)

Safety features

1. Anti telescopic feature and crumpled zones - The end wall construction have been made especially strong to ensure maximum safety to the passengers. The end walls have been provided with stanchions which absorbs impact energy and deform and thus do not allow coaches to get into one another during heavy impact.



2. Crumpled zone - It is a structural feature designed to absorb kinetic energy from the impact during collision by controlled deformation. The underframe near the end walls below the toilets contain tubular pipe structure which deform and absorb energy during collisions.



Safety features

3.Fire safety in coaches

Indian Railways is continuously enhancing fire worthiness of coaches by using more fire retardant furnishing materials like use of-

- a) Compreg board/ PVC for coach flooring
- b) Laminated sheets for roofs, ceiling wall and Partition paneling
- c) Fire retardant Rexene (Vinyl coated fabric)
- d) Cushioning material (Densified Thermal Bonded Polyester block) for seats and berth
- e) FRP windows and UIC vestibules
- f) Provision of fire and smoke detection system
- g) Portable fire extinguishes in all coaches
- h) Hammer to break window glasses in case of fire.
- i) Improved material for electrical fitting and fixtures such as MCB, Light fitting, terminal boards etc.

Safety features

3.Fire safety in coaches

a) Compreg board/ PVC at coach flooring for Indian Railways is used for making seats and berths of railway coaches. This product conforms to Railway Specifications as per RDSO-IS-C-9407. The veneers are pressed under high capacity hydraulic press under high temperature. Special additional treatment is also given to make product fire retardant according to IS:5509 and IS:15061 standards. The mandatory tests specified by railways are done in our fully equipped laboratories by the trained professionals from railway.



Safety features

3.Fire safety in coaches

b) Laminated sheets for roofs, ceiling wall and Partition paneling



Sleeper coach interior

Safety features

3.Fire safety in coaches

c) Fire retardant Rexene (Vinyl coated fabric)

d) Cushioning material (Densified Thermal Bonded Polyester block) for seats and berth



Safety features

3.Fire safety in coaches

e) FRP (Fibre reinforced Plastic) windows - It is composite material made of a polymer matrix reinforced with fibre. The fibres are usually glass (in fiberglass), Carbon (in carbon fibre reinforced polymer), Aramid, or Basalt.

e) UIC vestibules

- ▶ Double flap sliding door
- ▶ Manual opening and auto closing type door
- ▶ Hand safe feature
- ▶ Stainless Steel body filled with phenolic resin for better heat insulation
- ▶ Door opens only 250 mm when gangway bridge plate is in folded position.



Safety features

3.Fire safety in coaches

f) Provision of fire and smoke detection system - In its endeavor to prevent fire mishaps on trains, the Railways has undertaken steps to equip over 2,500 coaches with modern fire-and-smoke detection system.



Safety features

3.Fire safety in coaches

g) Portable fire extinguishes in all coaches

Portable fire extinguishers apply an extinguishing agent that will either cool burning fuel, displace or remove oxygen, or stop the chemical reaction so a fire cannot continue to burn. When the handle of an extinguisher is compressed, agent is expelled out the nozzle.



Safety features

3.Fire safety in coaches

h) Hammer to break window glasses in case of fire.

An emergency hammer is a safety device used in vehicles or buildings to break through window glass in an emergency. Emergency hammers are also known as bus mallets, dotty hammers, safety mallets, and bus hammers.



Safety features

3. Fire safety in coaches

i) Improved material for electrical fitting and fixtures such as MCB, Light fitting, terminal boards etc.



Safety features

4. Emergency Windows

All coaches in every train of the Indian Railways comes equipped with an emergency window for escape in case of accidents or other crisis situations. ... To remedy the situation.



Safety features

5. Couplers

The existing centre buffer coupler (CBC) is to be replaced with the new design CBC which has powerful shock absorbers. ... A coupler is a device for connecting coaches with each other in a train. The equipment that connects the couplings to the rolling stock is known as the draft gear

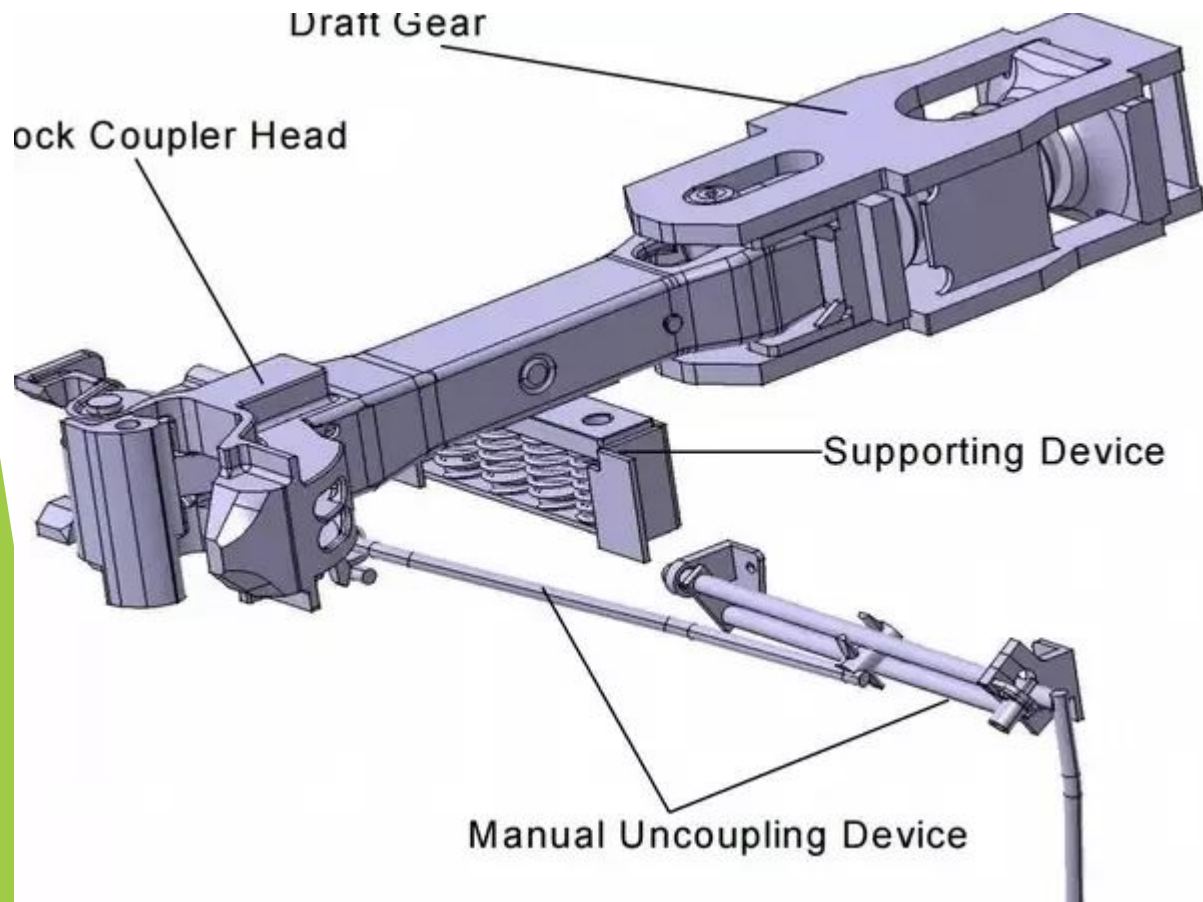

Safety features

6. Injury Free interior features

“CRASH-WORTHINESS” is achieved by making the interior parts of the coach in such a way that injury to passengers is minimized in the event of a minor collision or derailment or any other type of accident. When the passengers are thrown about, they hit the interior parts of the coach. At that point of time, the sharp corners and edges of the fittings and upholstery of the coach cause grievous injury to the passengers. They are also injured by falling luggage. In an effort to minimize the risk of such injuries many features are provided in the interior fittings of coaches.



Safety features

7. Bogie design

The FIAT Bogie is an adoption of EUROFIMA design. The Bogie frame is a Y frame fabricated and machined structure. There are Four nested springs for primary suspension and two nested flexi coil springs for secondary suspension. It has Axle mounted disc brake system.

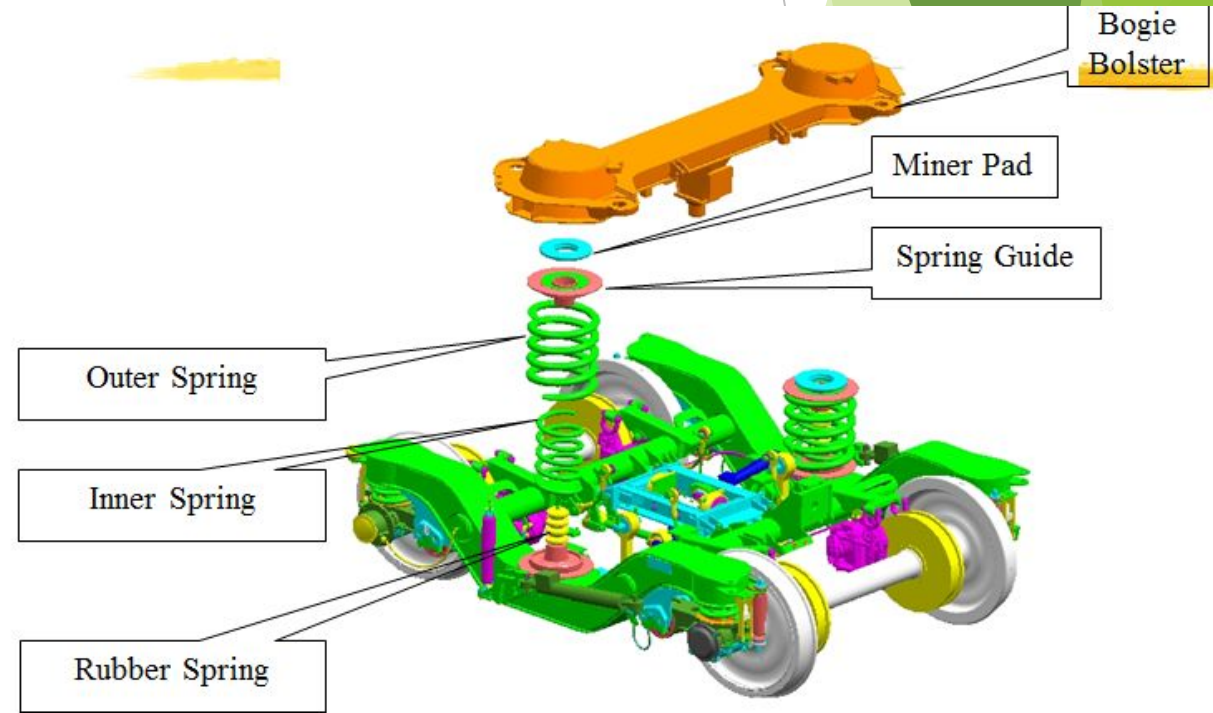

Safety features

8. Brakes Earlier hand brake were introduced followed by vacuum brakes. IR has dispensed with vacuum brake and now all the coaches are fitted with Air Brakes i.e. Pneumatic brake which are very effective even with higher loads. LHB coaches are provided with advanced pneumatic disc brake for efficient braking at higher speed.

Break Cylinder Size : 10 inch ,
Piston stroke :21 mm (max),
Slack capacity :160 mm (min),
BC pressure :3.0 kg/cm²,
Its having in build slack adjuster
No Manual adjustmentis required
to make after Brake pad
replacement .

Brake pad (35 mm)-32 nos (16 on each bogie ,2
on each caliper)

Check Points :

- i) Snap lock spring tension
- ii) Brake pad (35 mm) wear (minimum :7 mm)
- iii) Brake caliber pin iam



Brake pad

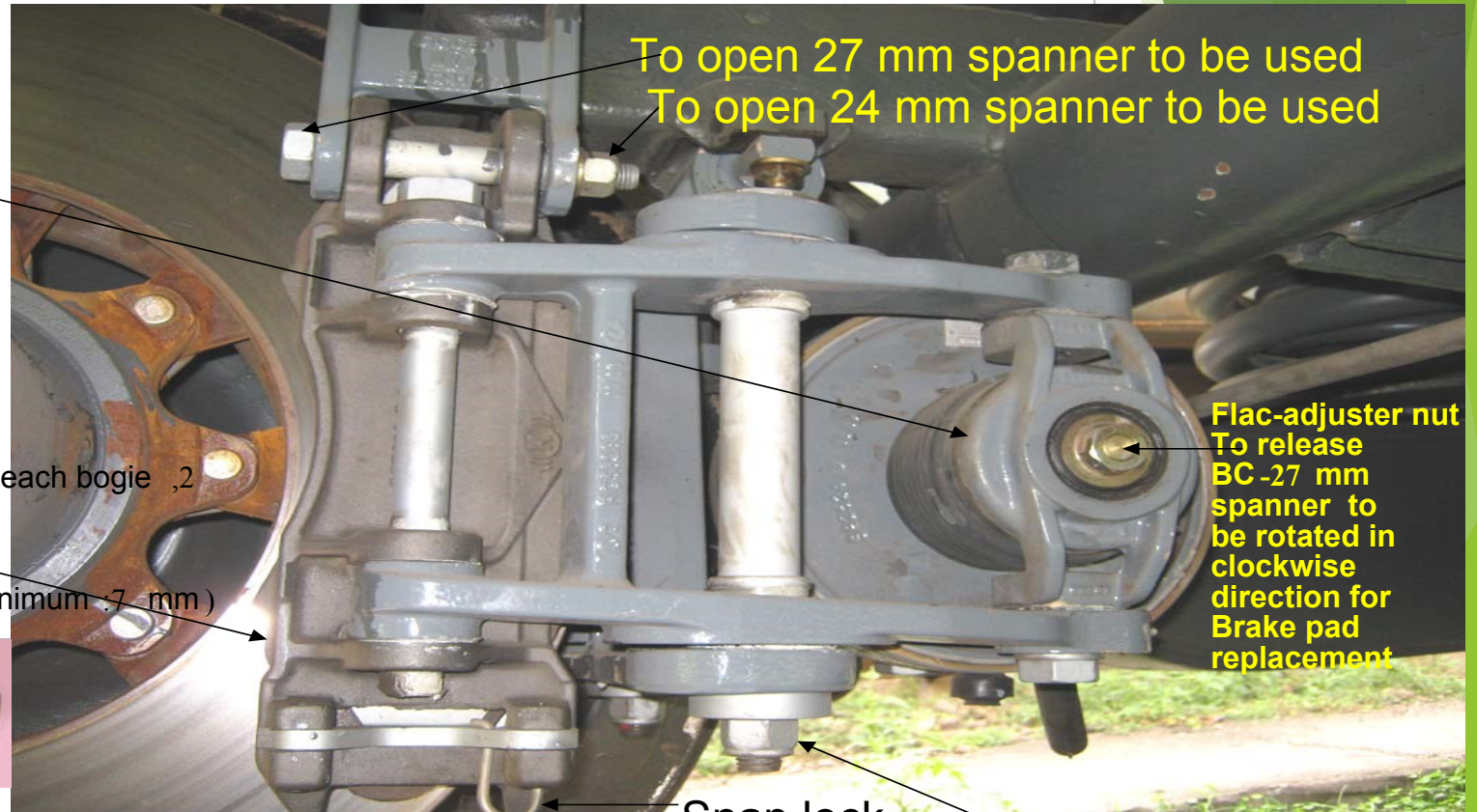

To open 27 mm spanner to be used
To open 24 mm spanner to be used

Flac-adjuster nut
To release
BC -27 mm
spanner to
be rotated in
clockwise
direction for
Brake pad
replacement

Snap lock

Brake pad manufacture
JURID 877 & BECORIT 984

Safety features

9. Passenger Emergency Pull Device



- Pulling the handle of passenger emergency alarm valves exhausts the BP pressure resulting in brake application

- o BP accelerator valve
- o Exhausts the BP pressure immediately to below 3 bar



- o Thereafter Emergency exhaust valve exhausts the BP pressure.

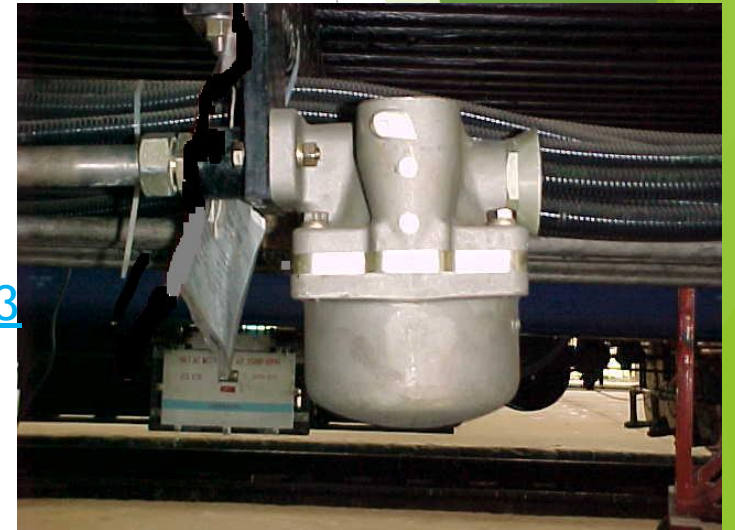

Safety features

10. Brake Accelerator (LHB Coach)

Brake accelerator for simultaneous brake application in a rake.
(Direct air release from BP to Atmosphere according to rate of fall of BP pressure)
Brake caliper unit KB make



Knorr Bremse Make



FTIL Make

Safety features

11. Wheel Slide Protection System (LHB Coach)

LHB coaches have speed sensor for all the wheels and any variation in the wheel RPM is recorded in the Micro controller which allows for brake application/release as need to be ensure that the brake binding or wheel slip is avoided.

**Speed sensor
&
Phonic wheel**

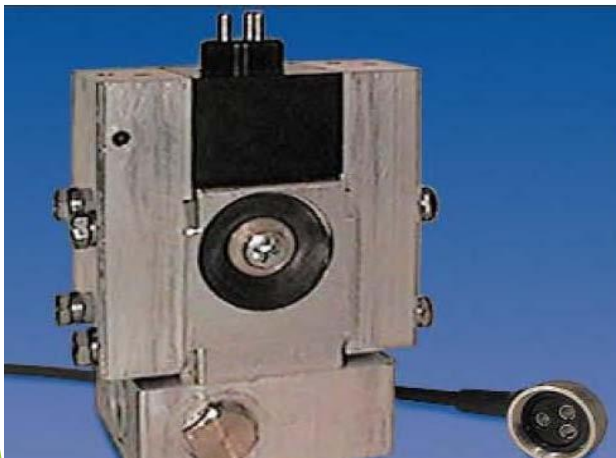

**Dump valve
&
Connector**

Safety features

12. Earthing Equipment in LHB Coaches (LHB Coaches)

(Available in Wheel no. 1 & 5)

Two manufacturer

- Darshan Enterprise, New Delhi,
- Chanda & Chanda, Kolkata

M8 allenbolt (6 mm allenkey to be used)

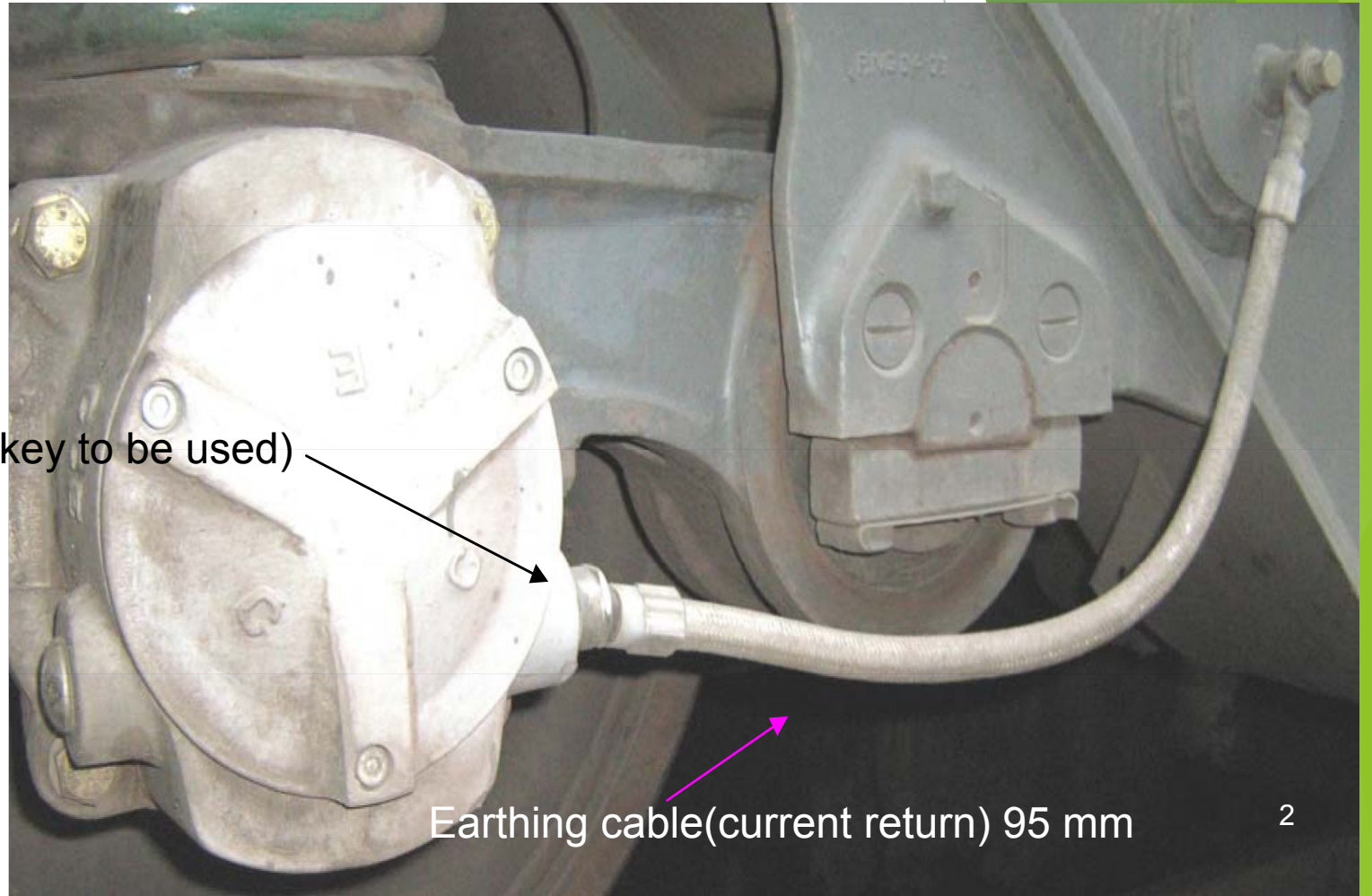

Earthing cable(current return) 95 mm

2

Wheel Set Earthing Equipment

Vehicle evacuation

Both ICF and LHB coaches have emergency window provision on either side of walls for evacuation of passengers during accidents. The LHB windows are wider in size and also easy to open thus permitting improved vehicle evacuation. The emergency window markings are made prominently in type of coaches. Four units are provided in I each coach to allow emergency evacuation of passenger in LHB coaches. A handle is connected to the rubber profile to open the glass unit of the emergency window. The breakage of glass unit while opening is preventing by a restraining chain.



Anti injury free features

ICF have introduced various anti free features in its coaches to ensure that the passenger do not get hurt in coach while travelling. The following are the anti free features introduced.

- ❑ All the soap holders in toilets and near wash basin have been covered into sunken type from projecting type.
- ❑ Mirror frame corners rounded off.
- ❑ Seats and berth corners rounded off.



Anti injury free features

ICF have introduced various anti free features in its coaches to ensure that the passenger do not get hurt in coach while travelling. The following are the anti free features introduced.

- ❑ Fan protective cage flat ribs changed to round section ribs to avoid head injury.
- ❑ Luggage hook made out of wire rope.
- ❑ Bottle holder changed from steel ones to nylon ones
- ❑ Bottle holder changed from fixed type to collapsible type



Anti injury free features

ICF have introduced various anti free features in its coaches to ensure that the passenger do not get hurt in coach while travelling. The following are the anti free features introduced.

- ❑ Coat hook changed from fixed one to swiveling one.
- ❑ Tray corner rounded off and made collapsible.
- ❑ Side lower berth joining latch made flat to avoid projection.



Indian Railways followed multi pronged approach with focus on new technologies, mechanization of maintenance, early detection of flaws: reduce human dependence, up gradation of skills of its human resource.

The technologies such as Train Protection Warning System, Anti Collision Devices (ACD), and Modified ACD have been provided on thousands of Kilometer route